

R88L-EA-AF-□

# Linear motor axis

## Advanced linear motor axis

High-efficiency iron-core linear motors and magnet tracks in a wide range of over 100 standard linear motor axis.

- Low moving mass to ensure a high degree of dynamism
- Optimized stroke/product length ratio
- Up to 5 m/s maximum speed with 1 μm repeatability
- Compact and efficiency oriented design
- Highly versatile and ready-to-use

## Ratings

- 230/400 VAC 48 to 760 N (2000 N peak force)



## System configuration

(Refer to servo drive chapter)

**SYNMAC**  
always in control

G5 servo drive  
EtherCAT model

Servo drive options

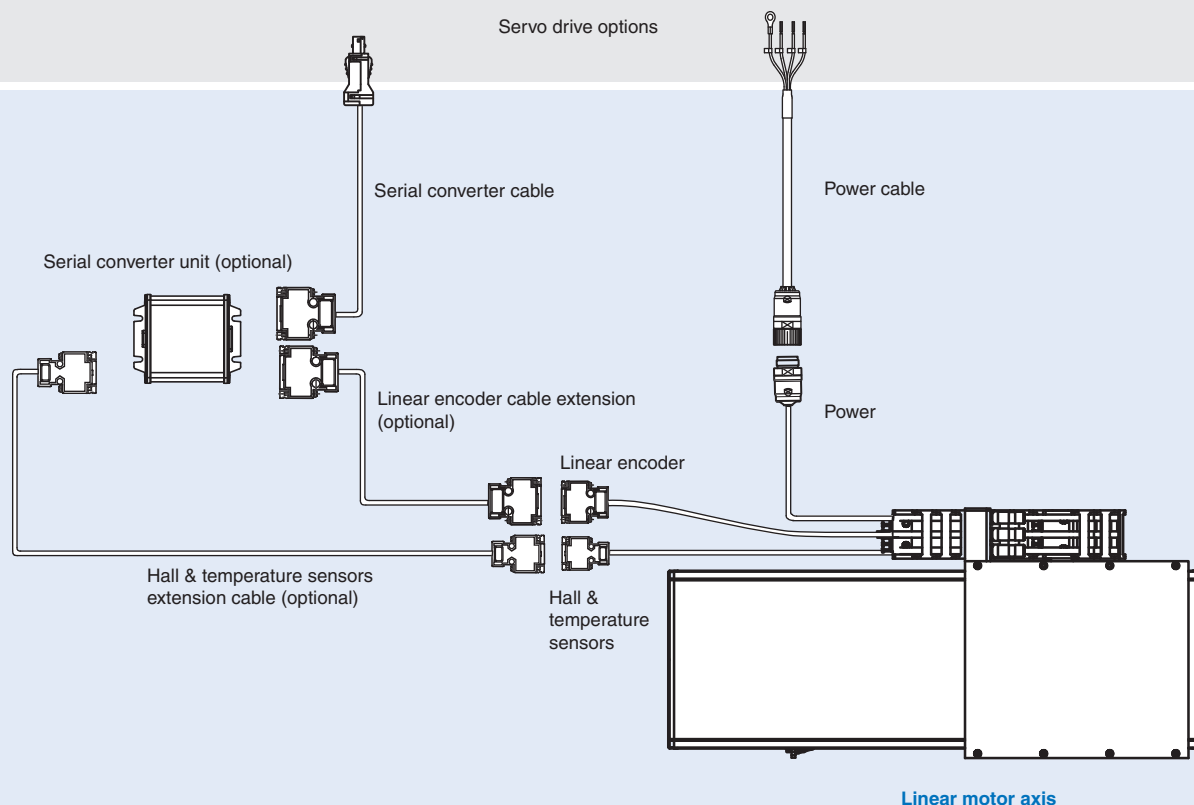

Linear motor/servo drive combination

Linear axis					Linear servo drive	
					G5 EtherCAT	
Type	Voltage	Rated force	Peak force	Model	230 V	400 V
R88L-EA-AF-□ Linear motor axis 	230/ 400 V	48 N	105 N	R88L-EA-AF-0303-□	R88D-KN02H-ECT-L	R88D-KN10F-ECT-L
		96 N	210 N	R88L-EA-AF-0306-□	R88D-KN04H-ECT-L	R88D-KN10F-ECT-L
		160 N	400 N	R88L-EA-AF-0606-□	R88D-KN08H-ECT-L	R88D-KN15F-ECT-L
		240 N	600 N	R88L-EA-AF-0609-□	R88D-KN10H-ECT-L	R88D-KN20F-ECT-L
		320 N	800 N	R88L-EA-AF-0612-□	R88D-KN15H-ECT-L	R88D-KN30F-ECT-L
		608 N	1600 N	R88L-EA-AF-1112-□	R88D-KN15H-ECT-L	R88D-KN30F-ECT-L
		760 N	2000 N	R88L-EA-AF-1115-□	R88D-KN15H-ECT-L	R88D-KN30F-ECT-L

Type designation

Linear motor axis

R88L - EA - AF - 0303 - 0110 - □

Linear motor axis

Customized versions

Iron-core linear motor model	
Code	Specifications
0303	30 mm active magnet width, 3 coil
0306	30 mm active magnet width, 6 coil
0606	60 mm active magnet width, 6 coil
0609	60 mm active magnet width, 9 coil
0612	60 mm active magnet width, 12 coil
1112	110 mm active magnet width, 12 coil
1115	110 mm active magnet width, 15 coil

Stroke length  
(for effective stroke distances available see dimensions section)

**Note:** The standard linear motor axis includes 1 Vpp SinCos encoder. For another encoder options or customized versions of linear axis please contact your OMRON representative.

**Linear servomotor specifications**

**Linear motor axis R88L-EA-AF-□ (230/400 VAC)**

Voltage		230/400 VAC							
Linear axis model	R88L-EA-AF-□	0303-□	0306-□	0606-□	0609-□	0612-□	1112-□	1115-□	
Motor specifications	Linear servo motor coil used	R88L-EC-FW-	0303	0306	0606	0609	0612	1112	1115
	Peak force <sup>*1</sup>	N	105	210	400	600	800	1600	2000
	Peak current <sup>*1</sup>	A <sub>rms</sub>	3.1	6.1	10	15	20	20	25
	Continuous force <sup>*2</sup>	N	48	96	160	240	320	608	760
	Continuous current <sup>*2</sup>	A <sub>rms</sub>	1.2	2.5	3.4	5.2	6.9	6.5	8.2
	Motor force constant	N/A <sub>rms</sub>	39.7		46.5			93.0	
	BEMF	V/m/s	32		38			76	
	Motor constant	N/√W	9.75	13.78	19.49	23.87	27.57	41.47	46.37
	Phase resistance	Ω	5.34	2.68	1.83	1.23	0.92	1.6	1.29
	Phase Inductance	mH	34.7	17.4	13.7	9.2	6.9	12.8	10.3
	Electrical time constant	ms	6.5		7.5			8	
Pole pitch	mm	24							
Mechanics	Weight of moving part	kg	3.1	3.9	5.4	6.7	7.9	13.7	15.9
	Recommended horizontal payload <sup>*3</sup>	kg	5		15			35	
	Uni-directional repeatability <sup>*3</sup>	μm	±1						
	Max. allowable speed	m/s	5						
	Min./max. standard stroke	mm	110/2126	158/2078	110/2126	158/2078	110/2030	110/2126	158/2174
Stroke increment	mm	96							
Feedback	Encoder type	1 Vptp SIN/COS & Reference mark, metalcase, optical, incremental							
	Encoder resolution	20 μm							
	Accuracy class	±5 μm/m							
	Hall sensor	Digital, TTL signals							
Other specifications	Protection methods <sup>*4</sup>	Temperature sensors (KTY-83/121 & PTC 110C), self cooling							
	Hall-Sensor supply	5 to 24 VDC, 25 mA							
	Encoder reading head supply	5 VDC, max. 250 mA							
	Insulation class	Class B							
	Max. bus voltage	560 VDC							
	Insulation resistance	500 VDC, min. 10 MΩ							
	Ambient humidity	20 to 80% (non-condensing)							
Altitude	1000 m								
Max. allowable magnet temperature	70°C								

\*1 Coil temperature rising by 6K/s.

\*2 Values at 100°C coil temperature and magnets at 25°C. An airstream of 2.5 m/s (25°C) has to be applied.

\*3 Referring to the center of gravity, for higher payload or different position of payload please contact your OMRON representative.

\*4 I<sup>2</sup>t has to be set properly for high current applications.

All other values at 25°C (±10%).

Center of gravity

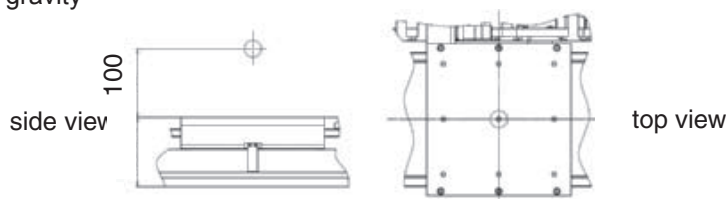

## Acceleration-payload characteristics

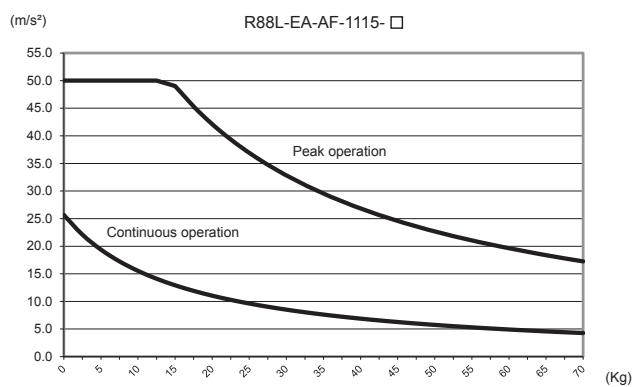
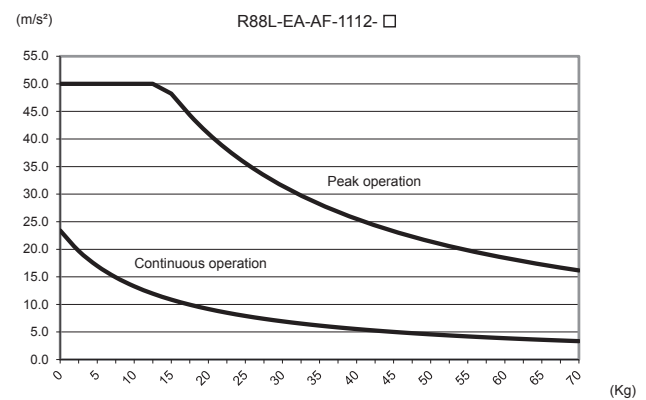
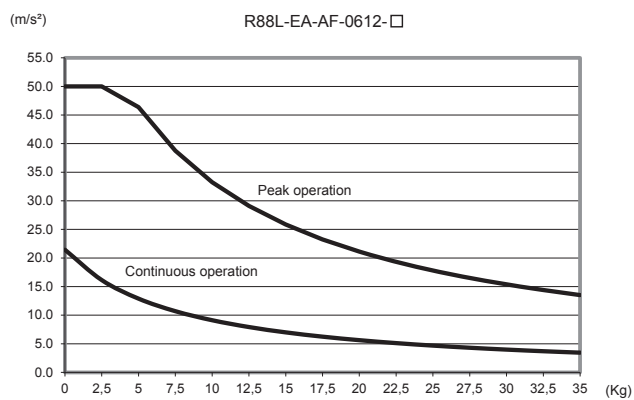
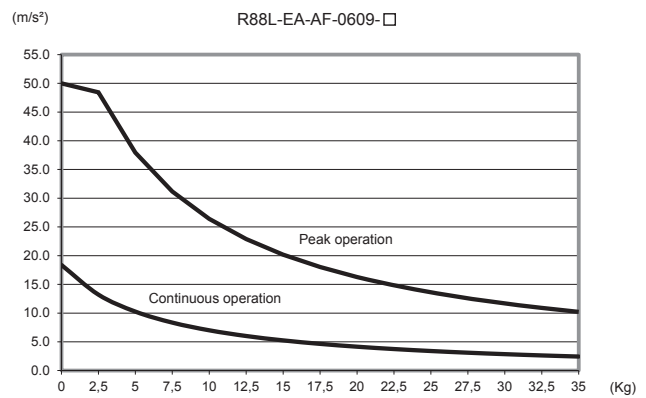
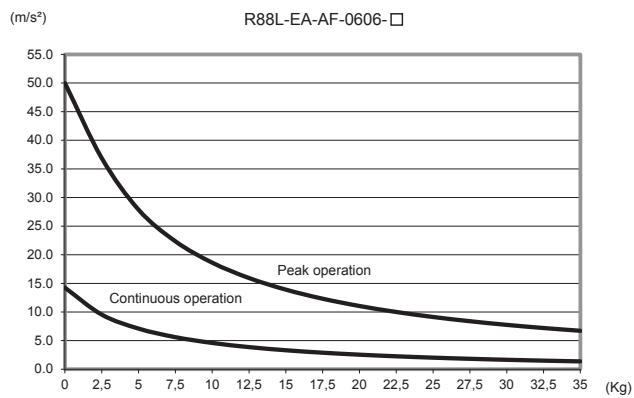
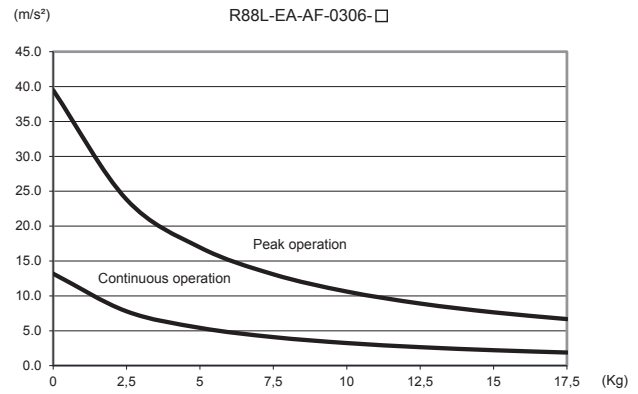
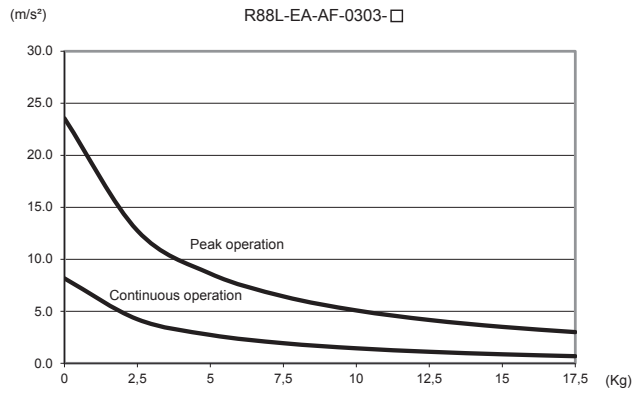

**Note:** The values on the above curves are calculated based on the below formula and with horizontal orientation:

$$Acceleration = (Force - Force_{Friction}) / Weigh_{Total}$$

Dimensions

R88L-EA-AF-0303-□ (230/400 VAC)

Linear axis model	Effective stroke in mm	L in mm	n	Nº of mounting holes	Weight of moving table including motor coil (kg)	Weight of the complete axis (kg)
R88L-EA-AF-0303-0110	110	312	2	6	3.1	9.5
R88L-EA-AF-0303-0206	206	408	3	8	3.1	10.9
R88L-EA-AF-0303-0302	302	504	4	10	3.1	12.4
R88L-EA-AF-0303-0398	398	600	5	12	3.1	13.8
R88L-EA-AF-0303-0494	494	696	6	14	3.1	15.2
R88L-EA-AF-0303-0590	590	792	7	16	3.1	16.7
R88L-EA-AF-0303-0686	686	888	8	18	3.1	18.1
R88L-EA-AF-0303-0782	782	984	9	20	3.1	19.6
R88L-EA-AF-0303-0878	878	1080	10	22	3.1	21.0
R88L-EA-AF-0303-0974	974	1176	11	24	3.1	22.5
R88L-EA-AF-0303-1070	1070	1272	12	26	3.1	23.9
R88L-EA-AF-0303-1166	1166	1368	13	28	3.1	25.4
R88L-EA-AF-0303-1262	1262	1464	14	30	3.1	26.8
R88L-EA-AF-0303-1358	1358	1560	15	32	3.1	28.2
R88L-EA-AF-0303-1454	1454	1656	16	34	3.1	29.7
R88L-EA-AF-0303-1550	1550	1752	17	36	3.1	31.1
R88L-EA-AF-0303-1646	1646	1848	18	38	3.1	32.6
R88L-EA-AF-0303-1742	1742	1944	19	40	3.1	34.0
R88L-EA-AF-0303-1838	1838	2040	20	42	3.1	35.5
R88L-EA-AF-0303-1934	1934	2136	21	44	3.1	36.9
R88L-EA-AF-0303-2030	2030	2232	22	46	3.1	38.3
R88L-EA-AF-0303-2126	2126	2328	23	48	3.1	39.8

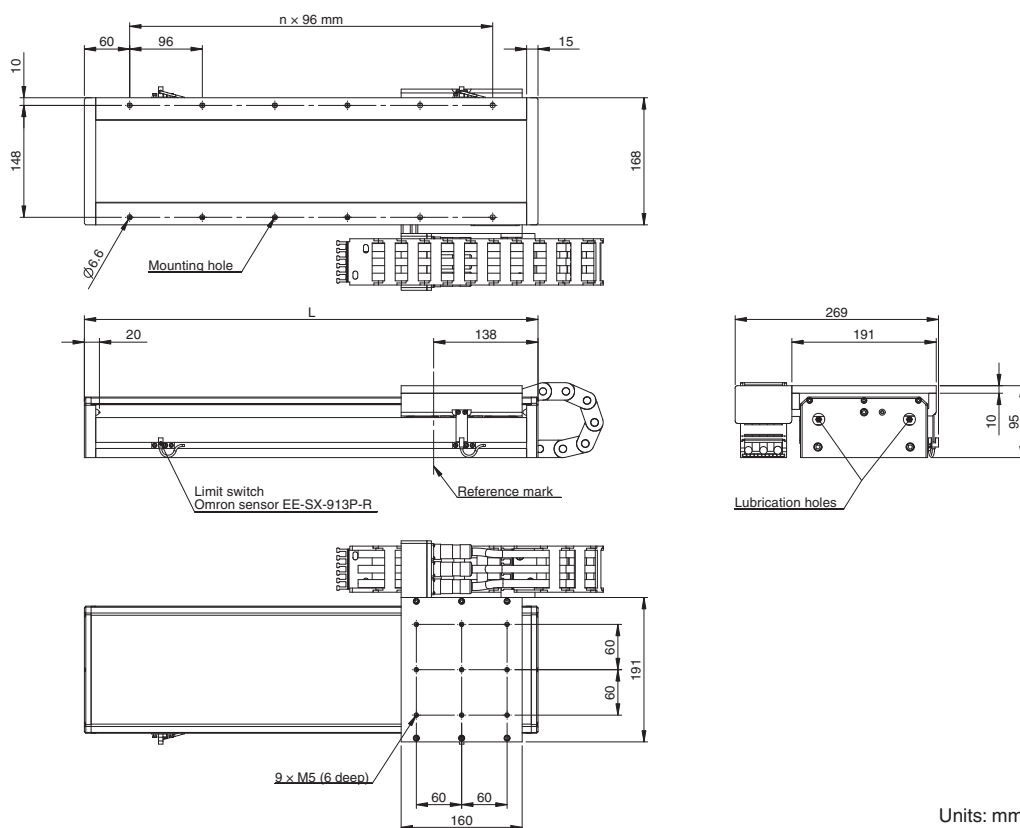

Units: mm

Hall sensor & temperature cable

Cable length 500 mm approx.  
Connector D-Sub 9 pins (male)



Pin No.	Name
1	5V
2	Hall U
3	Hall V
4	Hall W
5	GND
6	PTC
7	PTC
8	KTY
9	KTY
Case	Shield

Encoder cable

Cable length 500 mm approx.  
Connector D-Sub 15 pins (male)



Pin No.	Signal
1	SDA*
2	SCL*
3	Not used
4	/Ref signal (U <sub>o</sub> -)
5	/Cos signal (U <sub>z</sub> -)
6	/Sin signal (U <sub>i</sub> -)
7	Not used
8	5V
9	0V
10	Not used
11	Not used
12	Ref signal (U <sub>o</sub> )
13	Cos signal (U <sub>z</sub> )
14	Sin signal (U <sub>i</sub> )
15	Inner shield (IS)
Case	Shield

\*Reserved. Please do not use

Power cable

Cable length 500 mm approx.  
Connector HyperTAC  
LPR06AMRPN182 (male)  
Pin article code: 021.279.1020



Pin No.	Name
1	Phase U
2	Phase V
3	Ground
4	Phase W
5	Not used
6	Not used

Mating connector:  
Plug type: LPR06BFRBN170

## R88L-EA-AF-0306-□ (230/400 VAC)

Linear axis model	Effective stroke in mm	L in mm	n	N° of mounting holes	Weight of moving table including motor coil (kg)	Weight of the complete axis (kg)
R88L-EA-AF-0306-0158	158	408	3	8	3.9	11.6
R88L-EA-AF-0306-0254	254	504	4	10	3.9	13.1
R88L-EA-AF-0306-0350	350	600	5	12	3.9	14.5
R88L-EA-AF-0306-0446	446	696	6	14	3.9	15.9
R88L-EA-AF-0306-0542	542	792	7	16	3.9	17.4
R88L-EA-AF-0306-0638	638	888	8	18	3.9	18.8
R88L-EA-AF-0306-0734	734	984	9	20	3.9	20.3
R88L-EA-AF-0306-0830	830	1080	10	22	3.9	21.7
R88L-EA-AF-0306-0926	926	1176	11	24	3.9	23.2
R88L-EA-AF-0306-1022	1022	1272	12	26	3.9	24.6
R88L-EA-AF-0306-1118	1118	1368	13	28	3.9	26.1
R88L-EA-AF-0306-1214	1214	1464	14	30	3.9	27.5
R88L-EA-AF-0306-1310	1310	1560	15	32	3.9	28.9
R88L-EA-AF-0306-1406	1406	1656	16	34	3.9	30.4
R88L-EA-AF-0306-1502	1502	1752	17	36	3.9	31.8
R88L-EA-AF-0306-1598	1598	1848	18	38	3.9	33.3
R88L-EA-AF-0306-1694	1694	1944	19	40	3.9	34.7
R88L-EA-AF-0306-1790	1790	2040	20	42	3.9	36.2
R88L-EA-AF-0306-1886	1886	2136	21	44	3.9	37.6
R88L-EA-AF-0306-1982	1982	2232	22	46	3.9	39.0
R88L-EA-AF-0306-2078	2078	2328	23	48	3.9	40.5

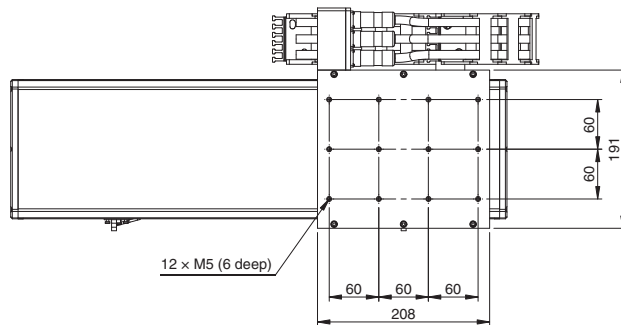
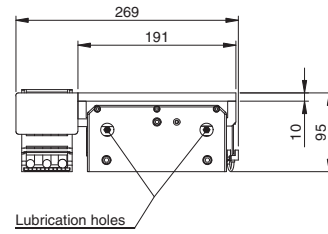
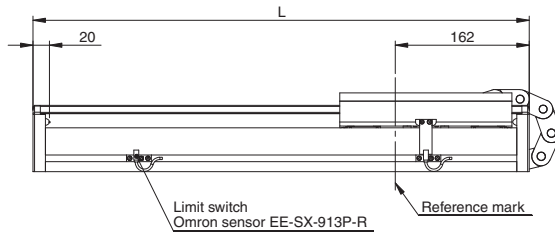
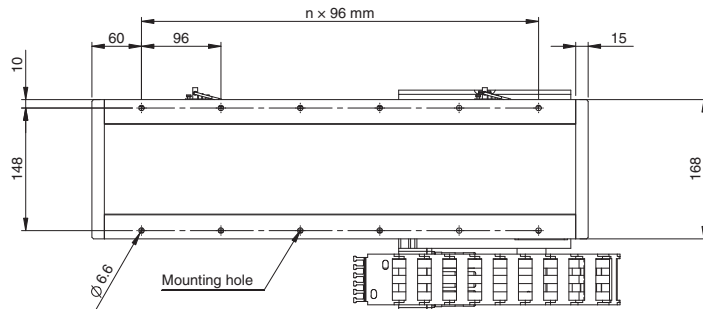

Units: mm

### Hall sensor & temperature cable

Cable length 500 mm approx.  
Connector D-Sub 9 pins (male)



Pin No.	Name
1	5 V
2	Hall U
3	Hall V
4	Hall W
5	GND
6	PTC
7	PTC
8	KTY
9	KTY
Case	Shield

### Encoder cable

Cable length 500 mm approx.  
Connector D-Sub 15 pins (male)

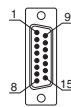

Pin No.	Signal
1	SDA*
2	SCL*
3	Not used
4	/Ref signal (U <sub>0</sub> -)
5	/Cos signal (U <sub>2</sub> -)
6	/Sin signal (U <sub>1</sub> -)
7	Not used
8	5 V
9	0 V
10	Not used
11	Not used
12	Ref signal (U <sub>0</sub> )
13	Cos signal (U <sub>2</sub> )
14	Sin signal (U <sub>1</sub> )
15	Inner shield (IS)
Case	Shield

\*Reserved. Please do not use

### Power cable

Cable length 500 mm approx.  
Connector Hyperfac  
LRRAG6AMRPN182 (male)  
Pin article code: 021.279.1020



Mating connector:  
Plug type: LPRA06BFRBN170

Pin No.	Name
1	Phase U
2	Phase V
3	Ground
4	Phase W
5	Not used
6	Not used

R88L-EA-AF-0606-□ (230/400 VAC)

Linear axis model	Effective stroke in mm	L in mm	n	Nº of mounting holes	Weight of moving table including motor coil (kg)	Weight of the complete axis (kg)
R88L-EA-AF-0606-0110	110	360	3	8	5.4	14.1
R88L-EA-AF-0606-0206	206	456	4	10	5.4	15.9
R88L-EA-AF-0606-0302	302	552	5	12	5.4	17.6
R88L-EA-AF-0606-0398	398	648	6	14	5.4	19.3
R88L-EA-AF-0606-0494	494	744	7	16	5.4	21.0
R88L-EA-AF-0606-0590	590	840	8	18	5.4	22.8
R88L-EA-AF-0606-0686	686	936	9	20	5.4	24.5
R88L-EA-AF-0606-0782	782	1032	10	22	5.4	26.2
R88L-EA-AF-0606-0878	878	1128	11	24	5.4	28.0
R88L-EA-AF-0606-0974	974	1224	12	26	5.4	29.7
R88L-EA-AF-0606-1070	1070	1320	13	28	5.4	31.4
R88L-EA-AF-0606-1166	1166	1416	14	30	5.4	33.2
R88L-EA-AF-0606-1262	1262	1512	15	32	5.4	34.9
R88L-EA-AF-0606-1358	1358	1608	16	34	5.4	36.6
R88L-EA-AF-0606-1454	1454	1704	17	36	5.4	38.4
R88L-EA-AF-0606-1550	1550	1800	18	38	5.4	40.1
R88L-EA-AF-0606-1646	1646	1896	19	40	5.4	41.8
R88L-EA-AF-0606-1742	1742	1992	20	42	5.4	43.6
R88L-EA-AF-0606-1838	1838	2088	21	44	5.4	45.3
R88L-EA-AF-0606-1934	1934	2184	22	46	5.4	47.0
R88L-EA-AF-0606-2030	2030	2280	23	48	5.4	48.8
R88L-EA-AF-0606-2126	2126	2376	24	50	5.4	50.5

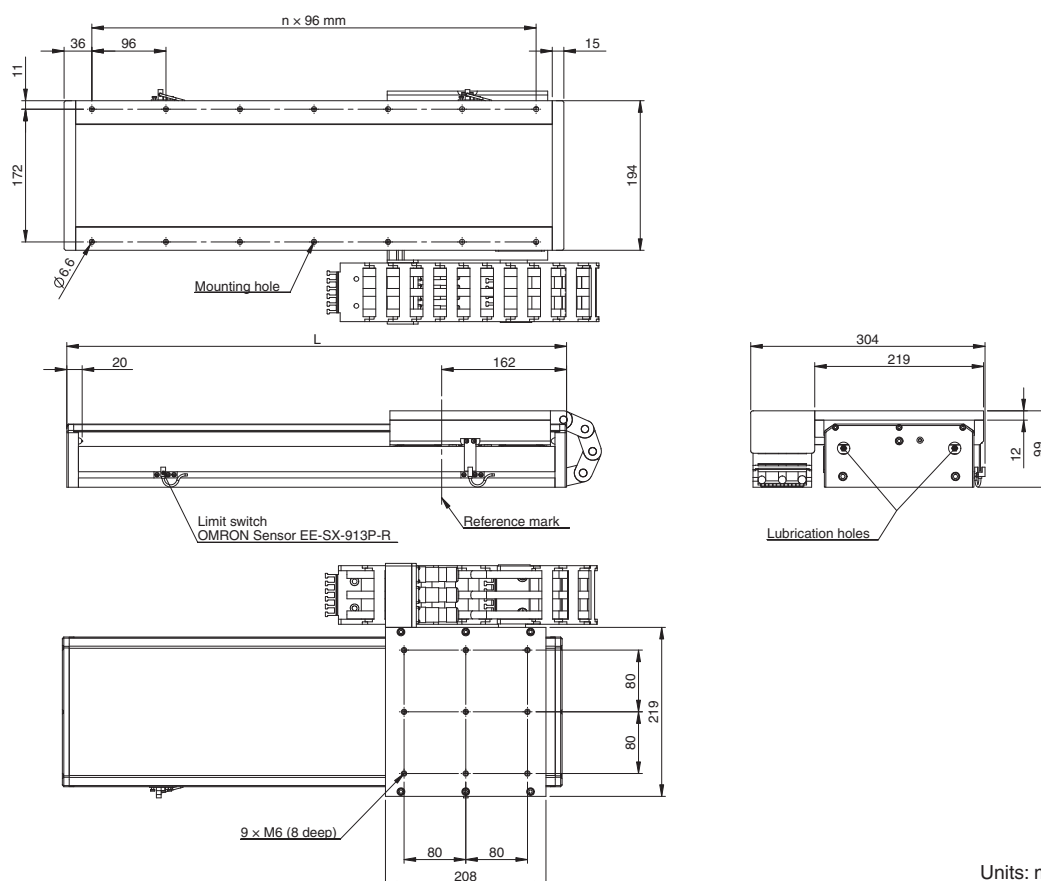

Units: mm

Hall sensor & temperature cable

Cable length 500 mm approx.  
Connector D-Sub 9 pins (male)



Pin No.	Name
1	5 V
2	Hall U
3	Hall V
4	Hall W
5	GND
6	PTC
7	PTC
8	KTY
9	KTY
Case	Shield

Encoder cable

Cable length 500 mm approx.  
Connector D-Sub 15 pins (male)



Pin No.	Signal
1	SDA*
2	SCL*
3	Not used
4	/Ref signal (U <sub>-</sub> )
5	/Cos signal (U <sub>z-</sub> )
6	/Sin signal (U <sub>1-</sub> )
7	Not used
8	5 V
9	0 V
10	Not used
11	Not used
12	Ref signal (U <sub>0</sub> )
13	Cos signal (U <sub>z</sub> )
14	Sin signal (U <sub>1</sub> )
15	Inner shield (IS)
Case	Shield

\*Reserved. Please do not use

Power cable

Cable length 500 mm approx.  
Connector Hypertac  
LRR06AMRPN182 (male)  
Pin article code: 021.279.1020



Pin No.	Name
1	Phase U
2	Phase V
3	Ground
4	Phase W
5	Not used
6	Not used

Mating connector:  
Plug type: LPR06BFRBN170

## R88L-EA-AF-0609-□ (230/400 VAC)

Linear axis model	Effective stroke in mm	L in mm	n	Nº of mounting holes	Weight of moving table including motor coil (kg)	Weight of the complete axis (kg)
R88L-EA-AF-0609-0158	158	456	4	10	6.7	17.2
R88L-EA-AF-0609-0254	254	552	5	12	6.7	18.9
R88L-EA-AF-0609-0350	350	648	6	14	6.7	20.6
R88L-EA-AF-0609-0446	446	744	7	16	6.7	22.3
R88L-EA-AF-0609-0542	542	840	8	18	6.7	24.1
R88L-EA-AF-0609-0638	638	936	9	20	6.7	25.8
R88L-EA-AF-0609-0734	734	1032	10	22	6.7	27.5
R88L-EA-AF-0609-0830	830	1128	11	24	6.7	29.3
R88L-EA-AF-0609-0926	926	1224	12	26	6.7	31.0
R88L-EA-AF-0609-1022	1022	1320	13	28	6.7	32.7
R88L-EA-AF-0609-1118	1118	1416	14	30	6.7	34.5
R88L-EA-AF-0609-1214	1214	1512	15	32	6.7	36.2
R88L-EA-AF-0609-1310	1310	1608	16	34	6.7	37.9
R88L-EA-AF-0609-1406	1406	1704	17	36	6.7	39.7
R88L-EA-AF-0609-1502	1502	1800	18	38	6.7	41.4
R88L-EA-AF-0609-1598	1598	1896	19	40	6.7	43.1
R88L-EA-AF-0609-1694	1694	1992	20	42	6.7	44.9
R88L-EA-AF-0609-1790	1790	2088	21	44	6.7	46.6
R88L-EA-AF-0609-1886	1886	2184	22	46	6.7	48.3
R88L-EA-AF-0609-1982	1982	2280	23	48	6.7	50.1
R88L-EA-AF-0609-2078	2078	2376	24	50	6.7	51.8

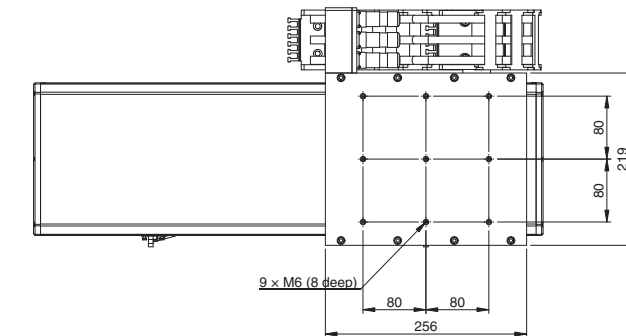
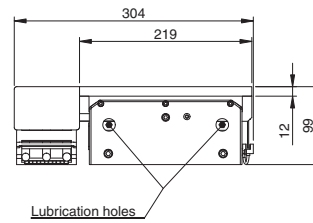
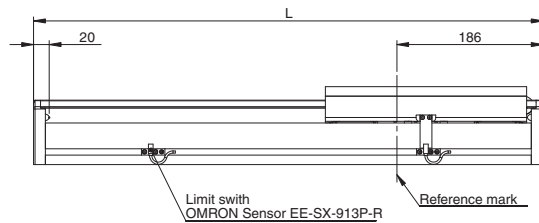
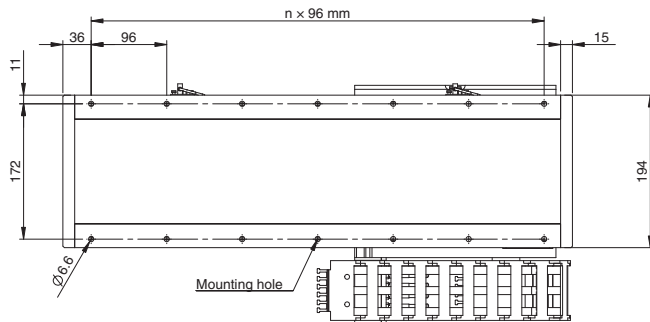

Units: mm

### Hall sensor & temperature cable

Cable length 500 mm approx.  
Connector D-Sub 9 pins (male)



Pin No.	Name
1	5 V
2	Hall U
3	Hall V
4	Hall W
5	GND
6	PTC
7	PTC
8	KTY
9	KTY
Case	Shield

### Encoder cable

Cable length 500 mm approx.  
Connector D-Sub 15 pins (male)



Pin No.	Signal
1	SDA*
2	SCL*
3	Not used
4	/Ref signal (U <sub>2</sub> -)
5	/Cos signal (U <sub>2</sub> -)
6	/Sin signal (U <sub>1</sub> -)
7	Not used
8	5 V
9	0 V
10	Not used
11	Not used
12	Ref signal (U <sub>0</sub> )
13	Cos signal (U <sub>2</sub> )
14	Sin signal (U <sub>1</sub> )
15	Inner shield (IS)
Case	Shield

\*Reserved. Please do not use

### Power cable

Cable length 500 mm approx.  
Connector HyperIac  
LPRAD6AMRPN182 (male)  
Pin article code: 021.278.1020



Mating connector:  
Plug type: LPRA06BFRBN170

Pin No.	Name
1	Phase U
2	Phase V
3	Ground
4	Phase W
5	Not used
6	Not used

R88L-EA-AF-06012-□ (230/400 VAC)

Linear axis model	Effective stroke in mm	L in mm	n	N° of mounting holes	Weight of moving table including motor coil (kg)	Weight of the complete axis (kg)
R88L-EA-AF-0612-0110	110	456	4	10	7.9	18.3
R88L-EA-AF-0612-0206	206	552	5	12	7.9	20.0
R88L-EA-AF-0612-0302	302	648	6	14	7.9	21.7
R88L-EA-AF-0612-0398	398	744	7	16	7.9	23.4
R88L-EA-AF-0612-0494	494	840	8	18	7.9	25.2
R88L-EA-AF-0612-0590	590	936	9	20	7.9	26.9
R88L-EA-AF-0612-0686	686	1032	10	22	7.9	28.6
R88L-EA-AF-0612-0782	782	1128	11	24	7.9	30.4
R88L-EA-AF-0612-0878	878	1224	12	26	7.9	32.1
R88L-EA-AF-0612-0974	974	1320	13	28	7.9	33.8
R88L-EA-AF-0612-1070	1070	1416	14	30	7.9	35.6
R88L-EA-AF-0612-1166	1166	1512	15	32	7.9	37.3
R88L-EA-AF-0612-1262	1262	1608	16	34	7.9	39.0
R88L-EA-AF-0612-1358	1358	1704	17	36	7.9	40.8
R88L-EA-AF-0612-1454	1454	1800	18	38	7.9	42.5
R88L-EA-AF-0612-1550	1550	1896	19	40	7.9	44.2
R88L-EA-AF-0612-1646	1646	1992	20	42	7.9	46.0
R88L-EA-AF-0612-1742	1742	2088	21	44	7.9	47.7
R88L-EA-AF-0612-1838	1838	2184	22	46	7.9	49.4
R88L-EA-AF-0612-1934	1934	2280	23	48	7.9	50.2
R88L-EA-AF-0612-2030	2030	2376	24	50	7.9	52.9

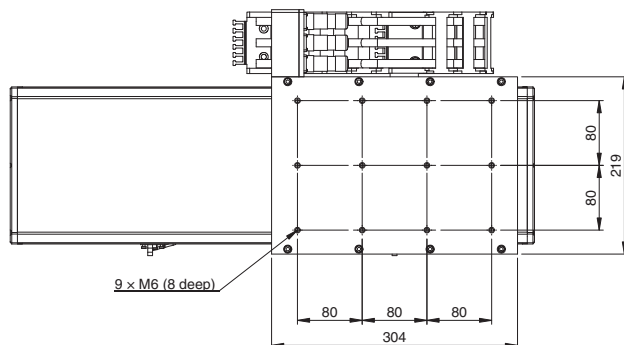
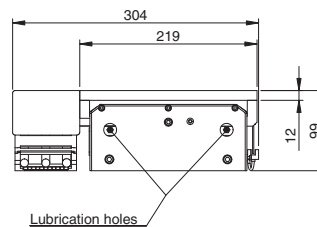
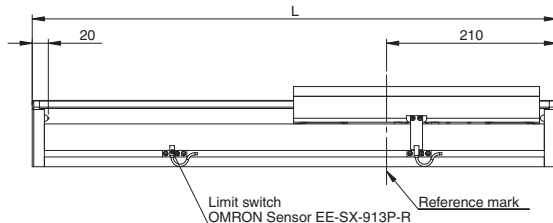
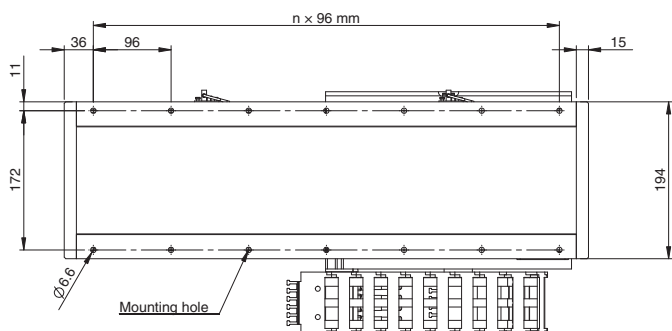

Units: mm

Hall sensor & temperature cable

Cable length 500 mm approx.  
Connector D-Sub 9 pins (male)



Pin No.	Name
1	5 V
2	Hall U
3	Hall V
4	Hall W
5	GND
6	PTC
7	PTC
8	KTY
9	KTY
Case	Shield

Encoder cable

Cable length 500 mm approx.  
Connector D-Sub 15 pins (male)



Pin No.	Signal
1	SDA*
2	SCL*
3	Not used
4	/Ref signal (U <sub>0</sub> -)
5	/Cos signal (U <sub>2</sub> -)
6	/Sin signal (U <sub>1</sub> -)
7	Not used
8	5 V
9	0 V
10	Not used
11	Not used
12	Ref signal (U <sub>0</sub> )
13	Cos signal (U <sub>2</sub> )
14	Sin signal (U <sub>1</sub> )
15	Inner shield (IS)
Case	Shield

\*Reserved. Please do not use

Power cable

Cable length 500 mm approx.  
Connector Hypertac  
LPRRA06AMRPN182 (male)  
Pin article code: 021.279.1020



Mating connector:  
Plug type: LPRRA06BFRBN170

Pin No.	Name
1	Phase U
2	Phase V
3	Ground
4	Phase W
5	Not used
6	Not used

## R88L-EA-AF-1112-□ (230/400 VAC)

Linear axis model	Effective stroke in mm	L in mm	n	Nº of mounting holes	Weight of moving table including motor coil (kg)	Weight of the complete axis (kg)
R88L-EA-AF-1112-0110	110	456	4	10	13.7	31.9
R88L-EA-AF-1112-0206	206	552	5	12	13.7	35.2
R88L-EA-AF-1112-0302	302	648	6	14	13.7	38.5
R88L-EA-AF-1112-0398	398	744	7	16	13.7	41.7
R88L-EA-AF-1112-0494	494	840	8	18	13.7	45.0
R88L-EA-AF-1112-0590	590	936	9	20	13.7	48.3
R88L-EA-AF-1112-0686	686	1032	10	22	13.7	51.5
R88L-EA-AF-1112-0782	782	1128	11	24	13.7	54.8
R88L-EA-AF-1112-0878	878	1224	12	26	13.7	58.1
R88L-EA-AF-1112-0974	974	1320	13	28	13.7	61.3
R88L-EA-AF-1112-1070	1070	1416	14	30	13.7	64.6
R88L-EA-AF-1112-1166	1166	1512	15	32	13.7	67.9
R88L-EA-AF-1112-1262	1262	1608	16	34	13.7	71.1
R88L-EA-AF-1112-1358	1358	1704	17	36	13.7	74.4
R88L-EA-AF-1112-1454	1454	1800	18	38	13.7	77.7
R88L-EA-AF-1112-1550	1550	1896	19	40	13.7	80.9
R88L-EA-AF-1112-1646	1646	1992	20	42	13.7	84.2
R88L-EA-AF-1112-1742	1742	2088	21	44	13.7	87.5
R88L-EA-AF-1112-1838	1838	2184	22	46	13.7	90.8
R88L-EA-AF-1112-1934	1934	2280	23	48	13.7	94.0
R88L-EA-AF-1112-2030	2030	2376	24	50	13.7	97.3
R88L-EA-AF-1112-2126	2126	2472	25	52	13.7	100.6

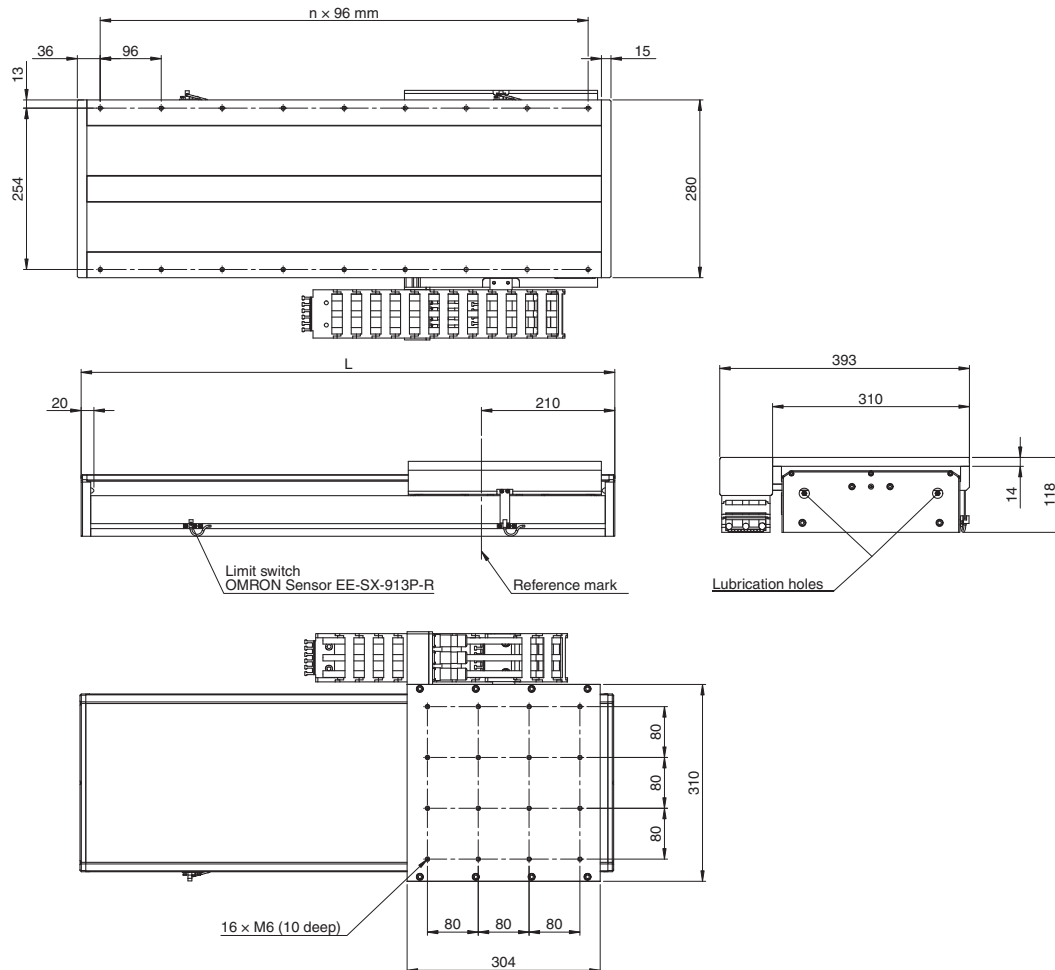

### Hall sensor & temperature cable

Cable length 500 mm approx.  
Connector D-Sub 9 pins (male)



Pin No.	Name
1	S V
2	Hall U
3	Hall V
4	Hall W
5	GND
6	PTC
7	PTC
8	KTY
9	KTY
Case	Shield

### Encoder cable

Cable length 500 mm approx.  
Connector D-Sub 15 pins (male)



Pin No.	Signal
1	SDA*
2	SCL*
3	Not used
4	[Ref signal (U <sub>1</sub> -)]
5	[Cos signal (U <sub>2</sub> -)]
6	[Sin signal (U <sub>1</sub> -)]
7	Not used
8	S V
9	12 V
10	Not used
11	Not used
12	Ref signal (U <sub>1</sub> )
13	Cos signal (U <sub>2</sub> )
14	Sin signal (U <sub>1</sub> )
15	Inner shield (IS)
Case	Shield

\*Reserved. Please do not use

### Power cable

Cable length 500 mm approx.  
Connector Hypertrac  
LFR1406SAMRPH182 (male)  
Pin article code: 021.279.1020



Mating connector:  
Plug type: LFR1406BFRBN170

Pin No.	Name
1	Phase U
2	Phase V
3	Ground
4	Phase W
5	Not used
6	Not used

Units: mm

R88L-EA-AF-1115-□ (230/400 VAC)

Linear axis model	Effective stroke in mm	L in mm	n	N° of mounting holes	Weight of moving table including motor coil (kg)	Weight of the complete axis (kg)
R88L-EA-AF-1115-0158	158	552	5	12	15.9	37.4
R88L-EA-AF-1115-0254	254	648	6	14	15.9	40.6
R88L-EA-AF-1115-0350	350	744	7	16	15.9	43.9
R88L-EA-AF-1115-0446	446	840	8	18	15.9	47.2
R88L-EA-AF-1115-0542	542	936	9	20	15.9	50.4
R88L-EA-AF-1115-0638	638	1032	10	22	15.9	53.7
R88L-EA-AF-1115-0734	734	1128	11	24	15.9	57.0
R88L-EA-AF-1115-0830	830	1224	12	26	15.9	60.2
R88L-EA-AF-1115-0926	926	1320	13	28	15.9	63.5
R88L-EA-AF-1115-1022	1022	1416	14	30	15.9	66.8
R88L-EA-AF-1115-1118	1118	1512	15	32	15.9	70.0
R88L-EA-AF-1115-1214	1214	1608	16	34	15.9	73.3
R88L-EA-AF-1115-1310	1310	1704	17	36	15.9	76.6
R88L-EA-AF-1115-1406	1406	1800	18	38	15.9	79.8
R88L-EA-AF-1115-1502	1502	1896	19	40	15.9	83.1
R88L-EA-AF-1115-1598	1598	1992	20	42	15.9	86.4
R88L-EA-AF-1115-1694	1694	2088	21	44	15.9	89.6
R88L-EA-AF-1115-1790	1790	2184	22	46	15.9	92.9
R88L-EA-AF-1115-1886	1886	2280	23	48	15.9	96.2
R88L-EA-AF-1115-1982	1982	2376	24	50	15.9	99.4
R88L-EA-AF-1115-2078	2078	2472	25	52	15.9	102.7
R88L-EA-AF-1115-2174	2174	2568	26	54	15.9	106.0

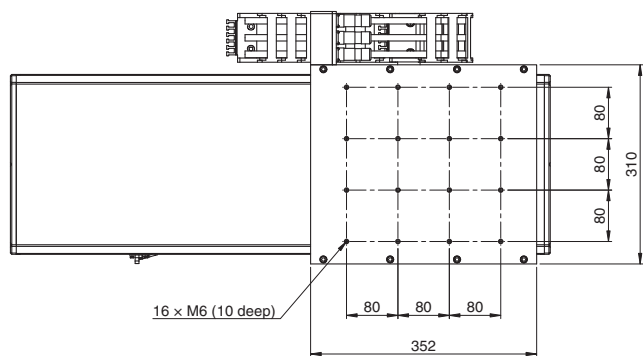
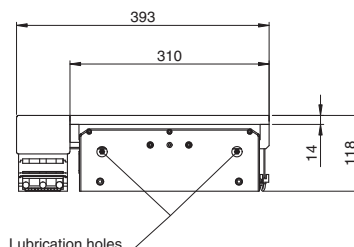
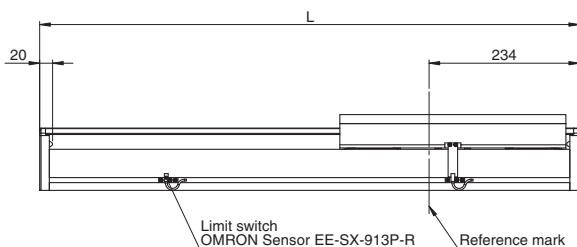
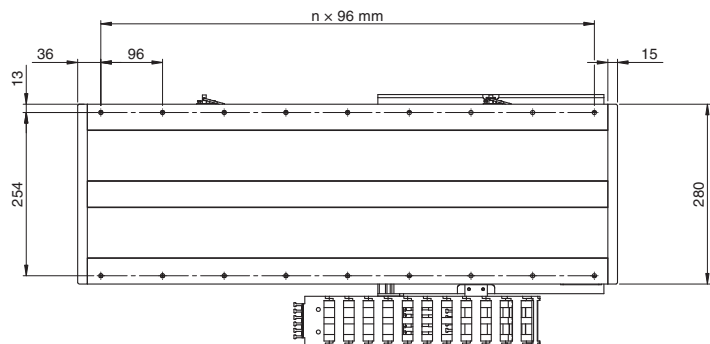

Hall sensor & temperature cable

Cable length 500 mm approx.  
Connector D-Sub 9 pins (male)



Pin No.	Name
1	5 V
2	Hall U
3	Hall V
4	Hall W
5	GND
6	PTC
7	PTC
8	KTY
9	KTY
Case	Shield

Encoder cable

Cable length 500 mm approx.  
Connector D-Sub 15 pins (male)



Pin No.	Signal
1	SDA*
2	SCL*
3	Not used
4	/Ref signal (Us.)
5	/Cos signal (Us.)
6	/Sin signal (Us.)
7	Not used
8	5 V
9	0 V
10	Not used
11	Not used
12	Ref signal (Ls)
13	Cos signal (Ls)
14	Sin signal (Ls)
15	Inner shield (IS)
Case	Shield

\*Reserved. Please do not use

Power cable

Cable length 500 mm approx.  
Connector Hypertac  
LRRA06AMPFN182 (male)  
Pin article code: 021.279.1020



Mating connector:  
Plug type: LPRA06FRBN170

Pin No.	Name
1	Phase U
2	Phase V
3	Ground
4	Phase W
5	Not used
6	Not used

Units: mm

## Optional serial converter unit

### Specifications

Serial converter model R88A-		SC01K-E	SC02K-E
Description		Serial converter from 1 Vpp to G5 serial data transmission and with hall sensor input	
Temperature sensor		KTY sensor detection of iron-core motor coil	NTC sensor detection of ironless motor coil
Electrical characteristics	Power supply voltage	5 VDC, max. 250 mA supplied by the drive	
	Standard resolution	Interpolation factor 100 plus quadrature count	
	Max. input frequency	400 kHz 1 Vpp	
	Analog input signals (cos, sin, Ref)	Differential input amplitude: 0.4 V to 1.2 V Input signal level: 1.5 V to 3.5 V	
	Output signals	Position data, hall & temperature sensor information, and alarms	
	Output method	Serial data transmission	
	Transmission cycle	<42 μs	
Mechanical characteristics	Vibration resistance	98 m/s <sup>2</sup> max. (1 to 2500 Hz) in three directions	
	Shock resistance	980 m/s <sup>2</sup> , (11 ms) two times in three directions	
Environmental conditions	Operating temperature	0 to 55°C	
	Storage temperature	-20 to 80°C	
	Humidity	20% to 90% relative humidity (without condensation)	

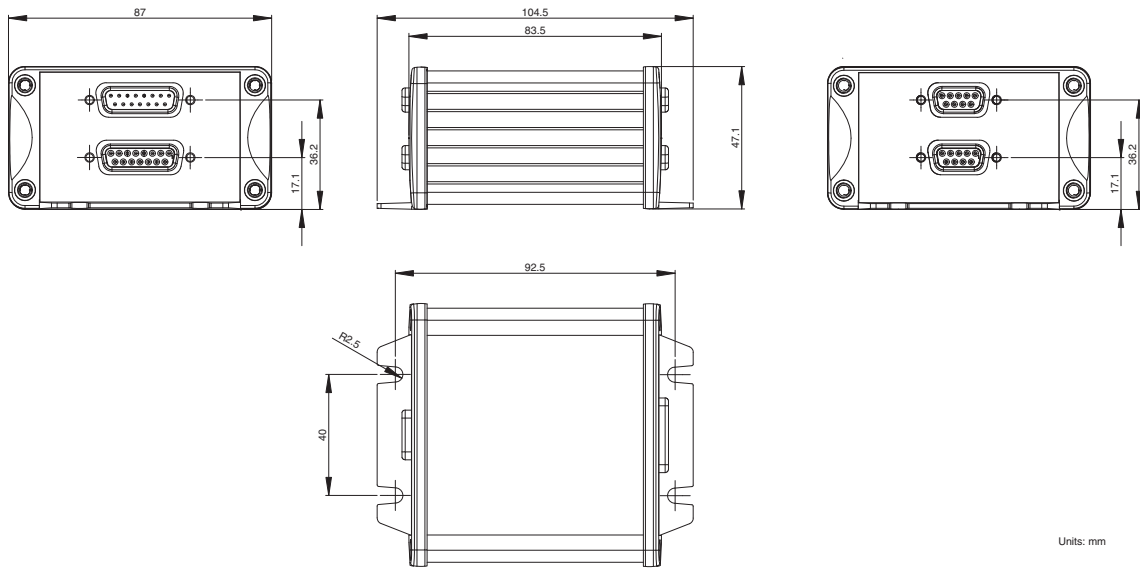

Units: mm

#### CN4

Serial data output to linear servo drive

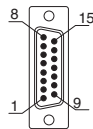

Connector D-Sub 15-pin (male)

Pin No.	Signal
1	PS
2	/PS
3	Not used
4	Not used
5	Not used
6	Not used
7	Not used
8	5 V
9	0 V
10	Not used
11	Not used
12	Not used
13	Not used
14	Not used
15	Inner shield
Case	Shield

#### CN3

Temperature sensor interface without hall sensor



Connector D-Sub 9-pin (female)

Pin No.	Signal
1	Not used
2	Not used
3	Not used
4	Not used
5	Not used
6	PTC
7	PTC
8	KTY/NTC
9	KTY/NTC
Case	Shield

#### CN1

Encoder input 1Vpp with programmable lines NUMERIK JENA standard

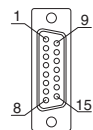

Connector D-Sub 15-pin (female)

Pin No.	Signal
1	SDA*
2	SCL*
3	Not used
4	/Ref signal (Uo-)
5	/Cos signal (U2-)
6	/Sin signal (U1-)
7	Not used
8	5 V
9	0 V
10	Not used
11	Not used
12	Ref signal (Uo)
13	Cos signal (U2)
14	Sin signal (U1)
15	Inner shield (IS)
Case	Shield

#### CN2

Hall & temperature sensors interface

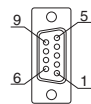

Connector D-Sub 9-pin (female)

Pin No.	Signal
1	5 V
2	Hall U
3	Hall V
4	Hall W
5	GND
6	PTC
7	PTC
8	KTY/NTC
9	KTY/NTC
Case	Shield

\*Reserved. Please do not use

**Note:** As the 6, 7, 8, 9 pins in the CN2 and CN3 connectors are internally wired, the temperature sensor can be connected to both connectors. When the hall sensor is also required, use the same cable for hall & temperature signals and the CN2 connector.

Ordering information

(Refer to servo drive chapter)

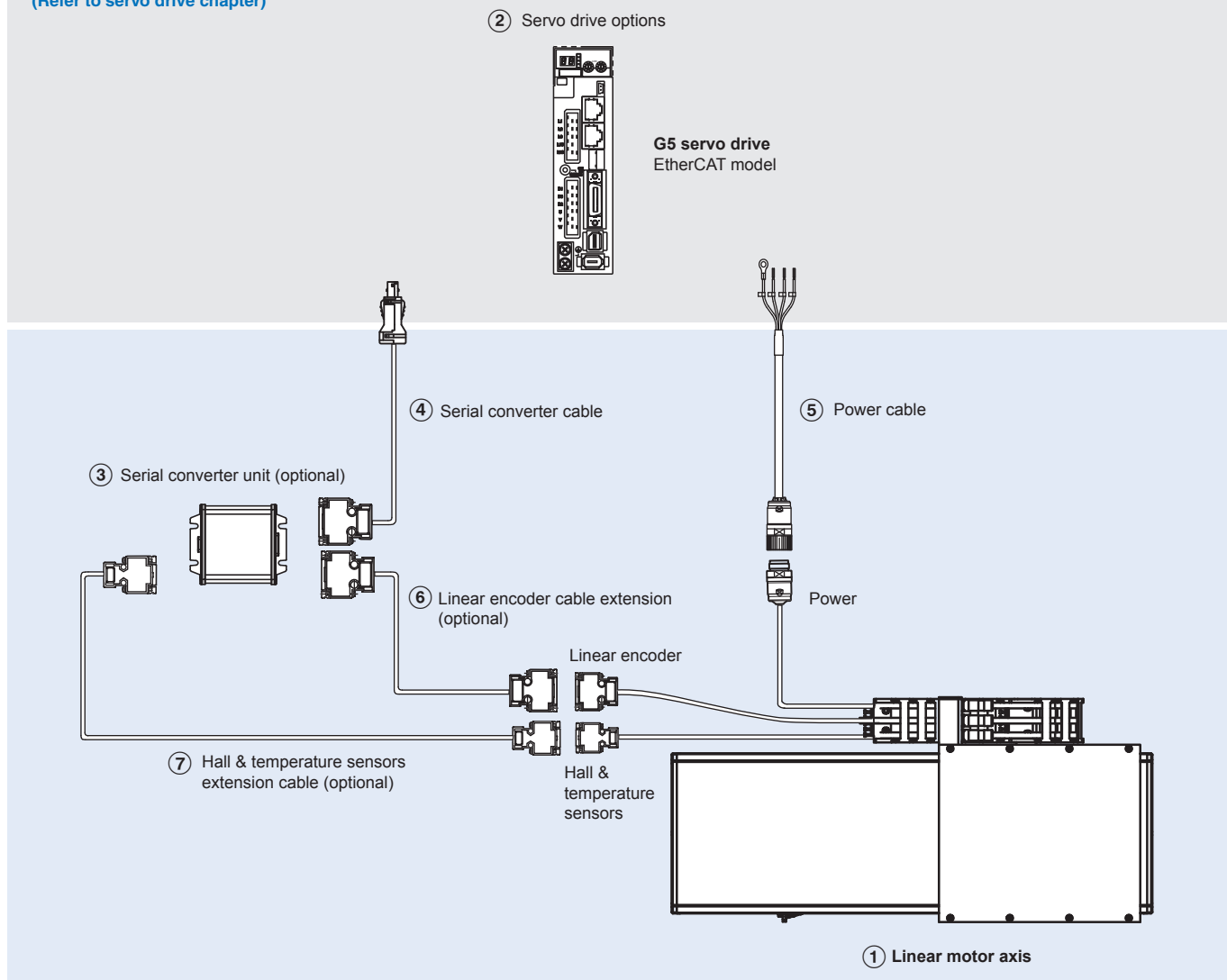

**Note:** The symbols ①②③... show the recommended sequence to select the servomotor, cables and serial converter for a linear motors system.

Linear motor axis

R88L-EA-AF-□

230 VAC single phase/400 VAC three phase

Symbol	Specifications		① Linear motor axis model	② Linear servo drive	
	Rated force	Peak force		G5 EtherCAT	
				230 V	400 V
①②	48 N	120 N	R88L-EA-AF-0303-□	R88D-KN02H-ECT-L	R88D-KN10F-ECT-L
	96 N	240 N	R88L-EA-AF-0306-□	R88D-KN04H-ECT-L	R88D-KN10F-ECT-L
	160 N	450 N	R88L-EA-AF-0606-□	R88D-KN08H-ECT-L	R88D-KN15F-ECT-L
	240 N	675 N	R88L-EA-AF-0609-□	R88D-KN10H-ECT-L	R88D-KN20F-ECT-L
	320 N	900 N	R88L-EA-AF-0612-□	R88D-KN15H-ECT-L	R88D-KN30F-ECT-L
	608 N	1800 N	R88L-EA-AF-1112-□	R88D-KN15H-ECT-L	R88D-KN30F-ECT-L
	760 N	2250 N	R88L-EA-AF-1115-□	R88D-KN15H-ECT-L	R88D-KN30F-ECT-L

**Note:** For effective stroke distances available see dimensions section.

## Servo drive

② Refer to G5 servo drive chapter for detailed drive specifications and selection of drive accessories.

## Serial converter unit

Symbol	Specifications	Model
③	Serial converter unit from 1 Vpp to G5 serial data transmission (with KTY sensor detection of iron-core motor coil)	R88A-SC01K-E
	Serial converter unit from 1 Vpp to G5 serial data transmission (with NTC sensor detection of ironless motor coil)	R88A-SC02K-E

**Note:** If no temperature sensor is needed, then it does not matter which converter you use.

## Serial converter cable to servo drive

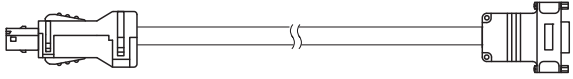
Symbol	Specifications	Model	Appearance	
④	G5 drive to serial converter cable. (Connectors R88A-CNK41L and DB-15)	1.5 m	R88A-CRKN001-5CR-E	
		3 m	R88A-CRKN003CR-E	
		5 m	R88A-CRKN005CR-E	
		10 m	R88A-CRKN010CR-E	
		15 m	R88A-CRKN015CR-E	
		20 m	R88A-CRKN020CR-E	

## Power cable

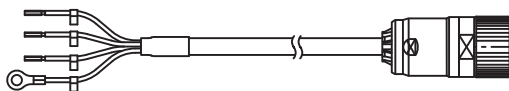
Symbol	Specifications	Model	Appearance	
⑤	For linear motor axis R88L-EA-AF-0303-□ R88L-EA-AF-0306-□	1.5 m	R88A-CAWK001-5S-DE	
		3 m	R88A-CAWK003S-DE	
		5 m	R88A-CAWK005S-DE	
		10 m	R88A-CAWK010S-DE	
		15 m	R88A-CAWK015S-DE	
		20 m	R88A-CAWK020S-DE	
	For linear motor axis R88L-EA-AF-0606-□ R88L-EA-AF-0609-□ R88L-EA-AF-0612-□ R88L-EA-AF-1112-□ R88L-EA-AF-1115-□	1.5 m	R88A-CAWL001-5S-DE	
		3 m	R88A-CAWL003S-DE	
		5 m	R88A-CAWL005S-DE	
		10 m	R88A-CAWL010S-DE	
		15 m	R88A-CAWL015S-DE	
		20 m	R88A-CAWL020S-DE	

## Linear encoder cable to serial converter

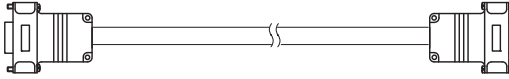
Symbol	Specifications	Model	Appearance	
⑧	Extension cable from linear encoder to serial converter. (Connector DB-15) (This extension cable is optional)	1.5 m	R88A-CFKA001-5CR-E	
		3 m	R88A-CFKA003CR-E	
		5 m	R88A-CFKA005CR-E	
		10 m	R88A-CFKA010CR-E	
		15 m	R88A-CFKA015CR-E	

## Hall and temperature sensors cable to serial converter

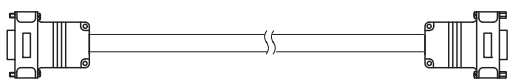
Symbol	Specifications	Model	Appearance	
⑦	Extension cable from hall and temperature sensors to serial converter. (Connector DB-9) (This extension cable is optional)	1.5 m	R88A-CFKB001-5CR-E	
		3 m	R88A-CFKB003CR-E	
		5 m	R88A-CFKB005CR-E	
		10 m	R88A-CFKB010CR-E	
		15 m	R88A-CFKB015CR-E	

## Connectors

Specification	Model
G5 servo drive encoder connector (for CN4)	R88A-CNK41L
Hypertac power cable connector IP67	LPRA-06B-FRBN170

ALL DIMENSIONS SHOWN ARE IN MILLIMETERS.  
To convert millimeters into inches, multiply by 0.03937. To convert grams into ounces, multiply by 0.03527.

# Terms and Conditions of Sale

1. **Offer; Acceptance.** These terms and conditions (these "**Terms**") are deemed part of all quotes, agreements, purchase orders, acknowledgments, price lists, catalogs, manuals, brochures and other documents, whether electronic or in writing, relating to the sale of products or services (collectively, the "**Products**") by Omron Electronics LLC and its subsidiary companies ("**Omron**"). Omron objects to any terms or conditions proposed in Buyer's purchase order or other documents which are inconsistent with, or in addition to, these Terms.
2. **Prices; Payment Terms.** All prices stated are current, subject to change without notice by Omron. Omron reserves the right to increase or decrease prices on any unshipped portions of outstanding orders. Payments for Products are due net 30 days unless otherwise stated in the invoice.
3. **Discounts.** Cash discounts, if any, will apply only on the net amount of invoices sent to Buyer after deducting transportation charges, taxes and duties, and will be allowed only if (i) the invoice is paid according to Omron's payment terms and (ii) Buyer has no past due amounts.
4. **Interest.** Omron, at its option, may charge Buyer 1-1/2% interest per month or the maximum legal rate, whichever is less, on any balance not paid within the stated terms.
5. **Orders.** Omron will accept no order less than \$200 net billing.
6. **Governmental Approvals.** Buyer shall be responsible for, and shall bear all costs involved in, obtaining any government approvals required for the importation or sale of the Products.
7. **Taxes.** All taxes, duties and other governmental charges (other than general real property and income taxes), including any interest or penalties thereon, imposed directly or indirectly on Omron or required to be collected directly or indirectly by Omron for the manufacture, production, sale, delivery, importation, consumption or use of the Products sold hereunder (including customs duties and sales, excise, use, turnover and license taxes) shall be charged to and remitted by Buyer to Omron.
8. **Financial.** If the financial position of Buyer at any time becomes unsatisfactory to Omron, Omron reserves the right to stop shipments or require satisfactory security or payment in advance. If Buyer fails to make payment or otherwise comply with these Terms or any related agreement, Omron may (without liability and in addition to other remedies) cancel any unshipped portion of Products sold hereunder and stop any Products in transit until Buyer pays all amounts, including amounts payable hereunder, whether or not then due, which are owing to it by Buyer. Buyer shall in any event remain liable for all unpaid accounts.
9. **Cancellation; Etc.** Orders are not subject to rescheduling or cancellation unless Buyer indemnifies Omron against all related costs or expenses.
10. **Force Majeure.** Omron shall not be liable for any delay or failure in delivery resulting from causes beyond its control, including earthquakes, fires, floods, strikes or other labor disputes, shortage of labor or materials, accidents to machinery, acts of sabotage, riots, delay in or lack of transportation or the requirements of any government authority.
11. **Shipping; Delivery.** Unless otherwise expressly agreed in writing by Omron:
  - a. Shipments shall be by a carrier selected by Omron; Omron will not drop ship except in "break down" situations.
  - b. Such carrier shall act as the agent of Buyer and delivery to such carrier shall constitute delivery to Buyer;
  - c. All sales and shipments of Products shall be FOB shipping point (unless otherwise stated in writing by Omron), at which point title and risk of loss shall pass from Omron to Buyer; provided that Omron shall retain a security interest in the Products until the full purchase price is paid;
  - d. Delivery and shipping dates are estimates only; and
  - e. Omron will package Products as it deems proper for protection against normal handling and extra charges apply to special conditions.
12. **Claims.** Any claim by Buyer against Omron for shortage or damage to the Products occurring before delivery to the carrier must be presented in writing to Omron within 30 days of receipt of shipment and include the original transportation bill signed by the carrier noting that the carrier received the Products from Omron in the condition claimed.
13. **Warranties.** (a) **Exclusive Warranty.** Omron's exclusive warranty is that the Products will be free from defects in materials and workmanship for a period of twelve months from the date of sale by Omron (or such other period expressed in writing by Omron). Omron disclaims all other warranties, express or implied. (b) **Limitations.** OMRON MAKES NO WARRANTY OR REPRESENTATION, EXPRESS OR IMPLIED, ABOUT NON-INFRINGEMENT, MERCHANTABILITY OR FITNESS FOR A PARTICULAR PURPOSE OF THE PRODUCTS. BUYER ACKNOWLEDGES THAT IT ALONE HAS DETERMINED THAT THE PRODUCTS WILL SUITABLY MEET THE REQUIREMENTS OF THEIR INTENDED USE. Omron further disclaims all warranties and responsibility of any type for claims or expenses based on infringement by the Products or otherwise of any intellectual property right. (c) **Buyer Remedy.** Omron's sole obligation hereunder shall be, at Omron's election, to (i) replace (in the form originally shipped with Buyer responsible for labor charges for removal or replacement thereof) the non-complying Product, (ii) repair the non-complying Product, or (iii) repay or credit Buyer an amount equal to the purchase price of the non-complying Product; provided that in no event shall Omron be responsible for warranty, repair, indemnity or any other claims or expenses regarding the Products unless Omron's analysis confirms that the Products were properly handled, stored, installed and maintained and not subject to contamination, abuse, misuse or inappropriate modification. Return of any Products by Buyer must be approved in writing by Omron before shipment. Omron Companies shall not be liable for the suitability or unsuitability or the results from the use of Products in combination with any electrical or electronic components, circuits, system assemblies or any other materials or substances or environments. Any advice, recommendations or information given orally or in writing, are not to be construed as an amendment or addition to the above warranty. See <http://www.omron247.com> or contact your Omron representative for published information.
14. **Limitation on Liability; Etc.** OMRON COMPANIES SHALL NOT BE LIABLE FOR SPECIAL, INDIRECT, INCIDENTAL, OR CONSEQUENTIAL DAMAGES, LOSS OF PROFITS OR PRODUCTION OR COMMERCIAL LOSS IN ANY WAY CONNECTED WITH THE PRODUCTS, WHETHER SUCH CLAIM IS BASED IN CONTRACT, WARRANTY, NEGLIGENCE OR STRICT LIABILITY. Further, in no event shall liability of Omron Companies exceed the individual price of the Product on which liability is asserted.
15. **Indemnities.** Buyer shall indemnify and hold harmless Omron Companies and their employees from and against all liabilities, losses, claims, costs and expenses (including attorney's fees and expenses) related to any claim, investigation, litigation or proceeding (whether or not Omron is a party) which arises or is alleged to arise from Buyer's acts or omissions under these Terms or in any way with respect to the Products. Without limiting the foregoing, Buyer (at its own expense) shall indemnify and hold harmless Omron and defend or settle any action brought against such Companies to the extent based on a claim that any Product made to Buyer specifications infringed intellectual property rights of another party.
16. **Property; Confidentiality.** Any intellectual property in the Products is the exclusive property of Omron Companies and Buyer shall not attempt to duplicate it in any way without the written permission of Omron. Notwithstanding any charges to Buyer for engineering or tooling, all engineering and tooling shall remain the exclusive property of Omron. All information and materials supplied by Omron to Buyer relating to the Products are confidential and proprietary, and Buyer shall limit distribution thereof to its trusted employees and strictly prevent disclosure to any third party.
17. **Export Controls.** Buyer shall comply with all applicable laws, regulations and licenses regarding (i) export of products or information; (ii) sale of products to "forbidden" or other proscribed persons; and (iii) disclosure to non-citizens of regulated technology or information.
18. **Miscellaneous.** (a) **Waiver.** No failure or delay by Omron in exercising any right and no course of dealing between Buyer and Omron shall operate as a waiver of rights by Omron. (b) **Assignment.** Buyer may not assign its rights hereunder without Omron's written consent. (c) **Law.** These Terms are governed by the law of the jurisdiction of the home office of the Omron company from which Buyer is purchasing the Products (without regard to conflict of law principles). (d) **Amendment.** These Terms constitute the entire agreement between Buyer and Omron relating to the Products, and no provision may be changed or waived unless in writing signed by the parties. (e) **Severability.** If any provision hereof is rendered ineffective or invalid, such provision shall not invalidate any other provision. (f) **Setoff.** Buyer shall have no right to set off any amounts against the amount owing in respect of this invoice. (g) **Definitions.** As used herein, "including" means "including without limitation"; and "Omron Companies" (or similar words) mean Omron Corporation and any direct or indirect subsidiary or affiliate thereof.

## Certain Precautions on Specifications and Use

1. **Suitability of Use.** Omron Companies shall not be responsible for conformity with any standards, codes or regulations which apply to the combination of the Product in the Buyer's application or use of the Product. At Buyer's request, Omron will provide applicable third party certification documents identifying ratings and limitations of use which apply to the Product. This information by itself is not sufficient for a complete determination of the suitability of the Product in combination with the end product, machine, system, or other application or use. Buyer shall be solely responsible for determining appropriateness of the particular Product with respect to Buyer's application, product or system. Buyer shall take application responsibility in all cases but the following is a non-exhaustive list of applications for which particular attention must be given: (i) Outdoor use, uses involving potential chemical contamination or electrical interference, or conditions or uses not described in this document. (ii) Use in consumer products or any use in significant quantities. (iii) Energy control systems, combustion systems, railroad systems, aviation systems, medical equipment, amusement machines, vehicles, safety equipment, and installations subject to separate industry or government regulations. (iv) Systems, machines and equipment that could present a risk to life or property. Please know and observe all prohibitions of use applicable to this Product. NEVER USE THE PRODUCT FOR AN APPLICATION INVOLVING SERIOUS RISK TO LIFE OR PROPERTY OR IN LARGE QUANTITIES WITHOUT ENSURING THAT THE SYSTEM AS A WHOLE HAS BEEN DESIGNED TO ADDRESS THE RISKS, AND THAT THE OMRON'S PRODUCT IS PROPERLY RATED AND INSTALLED FOR THE INTENDED USE WITHIN THE OVERALL EQUIPMENT OR SYSTEM.
2. **Programmable Products.** Omron Companies shall not be responsible for the user's programming of a programmable Product, or any consequence thereof.
3. **Performance Data.** Data presented in Omron Company websites, catalogs and other materials is provided as a guide for the user in determining suitability and does not constitute a warranty. It may represent the result of Omron's test conditions, and the user must correlate it to actual application requirements. Actual performance is subject to the Omron's Warranty and Limitations of Liability.
4. **Change in Specifications.** Product specifications and accessories may be changed at any time based on improvements and other reasons. It is our practice to change part numbers when published ratings or features are changed, or when significant construction changes are made. However, some specifications of the Product may be changed without any notice. When in doubt, special part numbers may be assigned to fix or establish key specifications for your application. Please consult with your Omron's representative at any time to confirm actual specifications of purchased Product.
5. **Errors and Omissions.** Information presented by Omron Companies has been checked and is believed to be accurate; however, no responsibility is assumed for clerical, typographical or proofreading errors or omissions.

**OMRON AUTOMATION AND SAFETY • THE AMERICAS HEADQUARTERS** • Chicago, IL USA • 847.843.7900 • 800.556.6766 • [www.omron247.com](http://www.omron247.com)

**OMRON CANADA, INC. • HEAD OFFICE**

Toronto, ON, Canada • 416.286.6465 • 866.986.6766 • [www.omron247.com](http://www.omron247.com)

**OMRON ELECTRONICS DE MEXICO • HEAD OFFICE**

México DF • 52.55.59.01.43.00 • 01-800-226-6766 • [mela@omron.com](mailto:mela@omron.com)

**OMRON ELECTRONICS DE MEXICO • SALES OFFICE**

Apodaca, N.L. • 52.81.11.56.99.20 • 01-800-226-6766 • [mela@omron.com](mailto:mela@omron.com)

**OMRON ELETRÔNICA DO BRASIL LTDA • HEAD OFFICE**

São Paulo, SP, Brasil • 55.11.2101.6300 • [www.omron.com.br](http://www.omron.com.br)

**OMRON ARGENTINA • SALES OFFICE**

Cono Sur • 54.11.4783.5300

**OMRON CHILE • SALES OFFICE**

Santiago • 56.9.9917.3920

**OTHER OMRON LATIN AMERICA SALES**

54.11.4783.5300

**OMRON EUROPE B.V.** • Wegalaan 67-69, NL-2132 JD, Hoofddorp, The Netherlands. • +31 (0) 23 568 13 00 • [www.industrial.omron.eu](http://www.industrial.omron.eu)

*Authorized Distributor:*

**Automation Control Systems**

- Machine Automation Controllers (MAC) • Programmable Controllers (PLC)
- Operator interfaces (HMI) • Distributed I/O • Software

**Drives & Motion Controls**

- Servo & AC Drives • Motion Controllers & Encoders

**Temperature & Process Controllers**

- Single and Multi-loop Controllers

**Sensors & Vision**

- Proximity Sensors • Photoelectric Sensors • Fiber-Optic Sensors
- Amplified Photomicrosensors • Measurement Sensors
- Ultrasonic Sensors • Vision Sensors

**Industrial Components**

- RFID/Code Readers • Relays • Pushbuttons & Indicators
- Limit and Basic Switches • Timers • Counters • Metering Devices
- Power Supplies

**Safety**

- Laser Scanners • Safety Mats • Edges and Bumpers • Programmable Safety Controllers • Light Curtains • Safety Relays • Safety Interlock Switches