

# Hub City™ Worm Gear Drives

## Single Reduction

### PowerCubeX® Worm Speed Reducer Catalog Ratings

#### Series 210

SERIES	INPUT RPM	RATIO	OUTPUT RPM	CONVENTIONAL OIL					PAO SYNTHETIC OIL			PAG SYNTHETIC OIL		
				MECH. INPUT HP	EFF. %	MECH. OUTPUT TORQUE	THERMAL INPUT HP	THERMAL OUTPUT TORQUE	INPUT HP	EFF. %	OUTPUT TORQUE	INPUT HP	EFF. %	OUTPUT TORQUE
210	2500	5	500	4.40	87.1	483	2.91	319	4.40	92.3	512	4.40	95.2	528
		7.5	333	3.55	86.1	578	2.17	353	3.55	91.2	612	3.55	94.1	631
		10	250	2.93	85.2	629	2.00	429	2.93	90.4	667	2.93	93.2	688
		15	167	2.19	83.0	686	1.45	454	2.19	87.9	727	2.19	90.7	750
		20	125	1.73	80.7	705	1.32	538	1.73	85.5	747	1.73	88.2	770
		25	100	1.42	79.2	707	1.19	592	1.42	83.9	749	1.42	86.5	772
		30	83.3	1.23	76.4	713	0.91	526	1.23	81.0	756	1.23	83.5	779
		40	62.5	0.97	72.5	706	0.84	611	0.97	76.9	748	0.97	79.3	772
		50	50.0	0.77	70.1	682	0.72	638	0.77	74.3	723	0.77	76.6	746
		60	41.7	0.65	65.8	651	0.61	611	0.65	69.8	690	0.65	71.9	712
	80	31.3	0.41	63.3	528	0.38	489	0.41	67.1	560	0.41	69.2	578	
	100	25.0	0.29	58.0	421	0.27	392	0.29	61.5	446	0.29	63.4	460	
	1750	5	350	3.89	86.3	605	2.80	435	3.89	91.5	641	3.89	94.4	661
		7.5	233	3.12	85.1	718	2.07	476	3.12	90.2	761	3.12	93.0	784
		10	175	2.50	84.2	758	1.91	579	2.50	89.3	803	2.50	92.0	828
		15	117	1.86	81.6	819	1.37	603	1.86	86.5	868	1.86	89.1	895
		20	87.5	1.50	79.0	839	1.25	699	1.50	83.7	890	1.50	86.3	917
		25	70.0	1.19	77.3	828	1.13	786	1.19	82.0	878	1.19	84.5	905
		30	58.3	1.06	74.2	847	0.86	680	1.06	78.7	898	1.06	81.1	926
		40	43.8	0.83	69.9	838	0.79	798	0.83	74.1	889	0.83	76.4	916
		50	35.0	0.66	67.3	798	THERMAL EQUALS MECHANICAL		0.66	71.4	846	0.66	73.6	873
		60	29.2	0.57	62.6	773			0.57	66.4	819	0.57	68.5	845
	80	21.9	0.35	60.1	607	0.35			63.7	644	0.35	65.7	664	
	100	17.5	0.25	54.5	487	0.25			57.8	516	0.25	59.5	532	
	1170	5	234	3.13	85.4	719	2.40	551	3.13	90.5	762	3.13	93.3	786
		7.5	156	2.50	84.0	849	1.58	537	2.50	89.0	900	2.50	91.8	928
		10	117	2.00	82.9	875	1.68	735	2.00	87.9	927	2.00	90.6	956
		15	78.0	1.50	79.9	940	1.29	808	1.50	84.7	996	1.50	87.3	1027
		20	58.5	1.16	77.0	961	THERMAL EQUALS MECHANICAL		1.16	81.6	1018	1.16	84.1	1050
		25	46.8	0.93	75.2	937			0.93	79.7	993	0.93	82.1	1024
		30	39.0	0.84	71.6	968			0.84	75.9	1026	0.84	78.3	1058
		40	29.3	0.66	66.9	958			0.66	70.9	1015	0.66	73.1	1047
		50	23.4	0.52	64.2	901			0.52	68.0	956	0.52	70.1	985
		60	19.5	0.46	59.1	883			0.46	62.6	936	0.46	64.6	964
	80	14.6	0.28	56.6	676	0.28	60.0	717	0.28	61.8	739			
	100	11.7	0.200	50.8	546	0.200	53.8	578	0.200	55.5	596			
	100	5	20.0	0.40	79.4	989	THERMAL EQUALS MECHANICAL		0.40	84.2	1049	0.40	86.8	1081
		7.5	13.3	0.32	77.0	1158			0.32	81.6	1228	0.32	84.1	1266
		10	10.0	0.239	75.7	1140			0.239	80.3	1208	0.239	82.7	1246
		15	6.7	0.180	71.0	1211			0.180	75.3	1284	0.180	77.6	1323
		20	5.0	0.147	66.6	1233			0.147	70.6	1307	0.147	72.8	1347
		25	4.0	0.116	64.4	1176			0.116	68.2	1246	0.116	70.3	1285
		30	3.3	0.111	59.1	1238			0.111	62.6	1313	0.111	64.6	1353
		40	2.5	0.092	53.0	1224			0.092	56.2	1297	0.092	57.9	1338
		50	2.0	0.071	50.2	1128			0.071	53.2	1195	0.071	54.9	1232
60		1.7	0.068	43.9	1127	0.068			46.6	1195	0.068	48.0	1232	
80	1.3	0.039	42.4	825	0.039	44.9	874	0.039	46.3	901				
100	1.0	0.029	36.2	672	0.029	38.4	713	0.029	39.6	735				

ADDITIONAL RATINGS FOR OTHER INPUT SPEEDS ARE AVAILABLE AT WWW.REGALBELOIT.COM

#### OVERHUNG LOAD AND THRUST LOAD INFORMATION

OVERHUNG LOAD - LOW SPEED SHAFT — MODELS 211 AND 214 550 LBS. AT CENTER POINT OF SHAFT EXTENSION. MODELS 212 AND 215 NOT APPLICABLE. THRUST± UP OR DOWN 600 LBS.

±OHL AND THRUST VALUES SHOWN ARE INDEPENDENT FUNCTIONS AND CANNOT BE APPLIED SIMULTANEOUSLY. REFER APPLICATIONS WITH COMBINED OHL AND THRUST TO REGAL CUSTOMER SERVICE DEPARTMENT.

OUTPUT TORQUE VALUES SHOWN ARE INCH-POUNDS (IN-LB).

# Hub City™ Worm Gear Drives

## Single Reduction Models

136, 186, 216, 246, 266, 326, 386 (STEEL BRACKET)

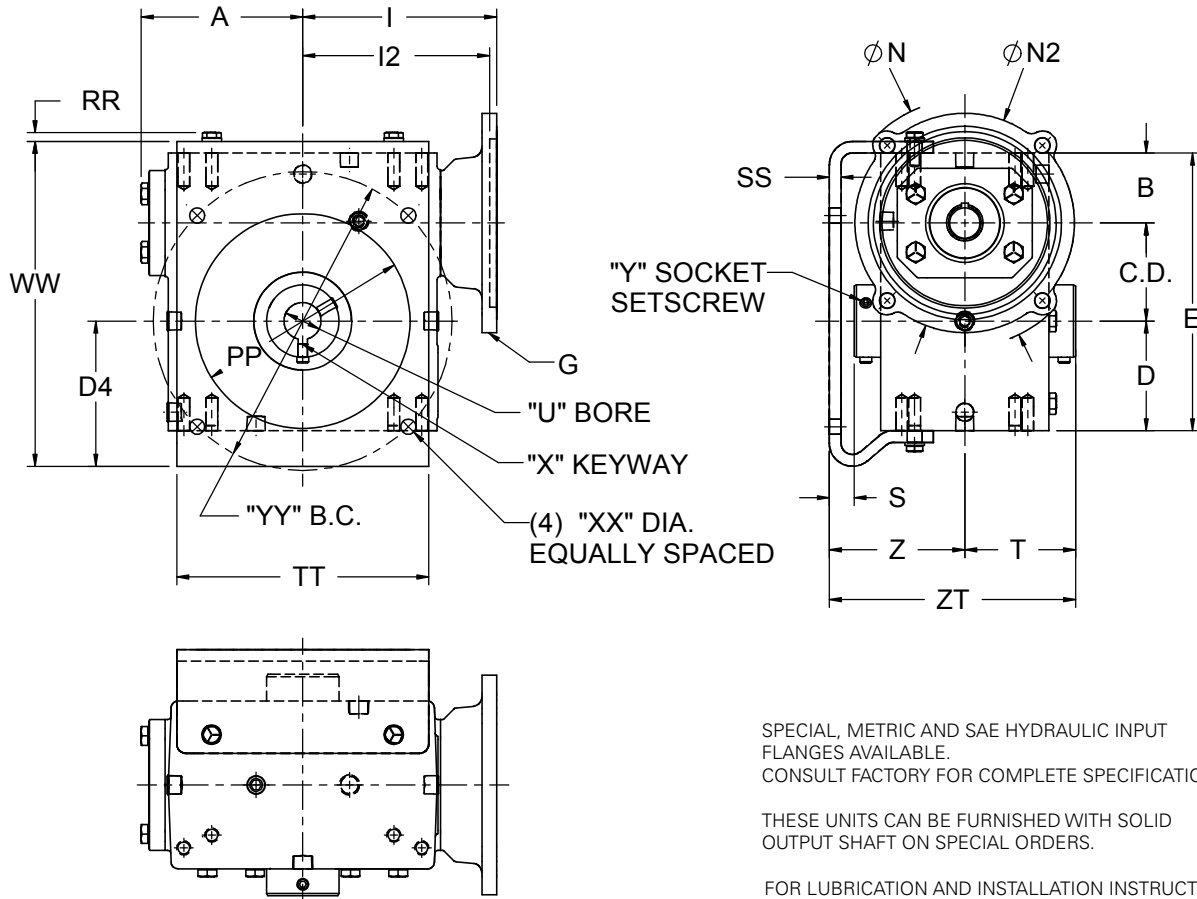

SPECIAL, METRIC AND SAE HYDRAULIC INPUT FLANGES AVAILABLE. CONSULT FACTORY FOR COMPLETE SPECIFICATIONS.

THESE UNITS CAN BE FURNISHED WITH SOLID OUTPUT SHAFT ON SPECIAL ORDERS.

FOR LUBRICATION AND INSTALLATION INSTRUCTIONS - REFER TO SECTION M

DIMENSIONS SHOWN ARE FOR REFERENCE ONLY. DOWNLOAD AVAILABLE CAD MODELS AT: [WWW.HUBCITYINC.COM](http://WWW.HUBCITYINC.COM)

### Standard Styles Available

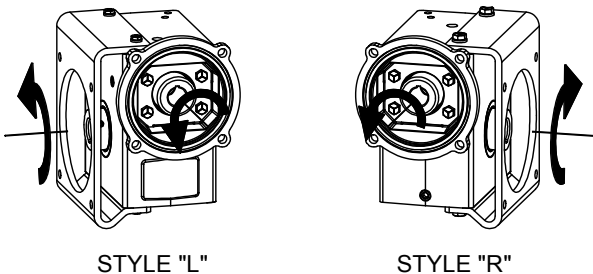

CONSULT FACTORY FOR VERTICAL SHAFT LUBRICATION RECOMMENDATIONS. INPUT SHAFT CAN BE ROTATED IN EITHER DIRECTION.

# Hub City™ Worm Gear Drives

## Single Reduction Models

136, 186, 216, 246, 266, 326, 386 (STEEL BRACKET)

MODEL	C.D.	A	B	D	E	G	I	I2	N	N2		
136	1.334	2.61	1.186	1.562	4.082	48CZ	3.46	N/A	4.36	3.87		
						56C			6.63	6.50		
186	1.751	3.23	1.374	1.875	5.000	48CZ	4.09	N/A	4.36	3.87		
						56C			6.63	6.50		
						143TC			6.63	6.50		
216	2.064	3.61	1.500	2.437	6.000	48CZ	4.46	N/A	4.36	3.87		
						56C			6.63	6.50		
						143TC			6.63	6.50		
246 *	2.376	3.77	2.061	2.500	6.937	56C	4.63	N/A	6.50	6.50		
						143TC			6.50	6.50		
						182TC			N/A	5.06	9.00	9.00
266	2.626	4.33	1.874	2.938	7.438	56C	5.19	N/A	6.50	6.50		
						143TC			6.50	6.50		
						182TC			N/A	5.81	9.00	9.00
326	3.251	5.28	2.124	3.250	8.625	56C	6.14	N/A	6.50	6.50		
						143TC			6.50	6.50		
						182TC			N/A	6.34	9.00	9.00
						213TC			N/A	6.90	9.00	9.00
386	3.751	4.90	2.374	3.937	10.062	56C	6.50	N/A	6.50	6.50		
						143TC			6.50	6.50		
						182TC			N/A	6.88	9.00	9.00

\* Model 246 also available with cast F-flange as either an add-on kit (see page B-103) or as a special assembly (consult factory).

MODEL	G	D4	PP	RR	SS	TT	WW	XX	YY	Wt. Lbs.
136	48CZ	2,50	3,62	0,22	0,19	4,25	5,22	11/32	5,000	18
	56C									
186	48CZ	3,13	4,25	0,22	0,25	4,88	6,50	11/32	5,875	18
	56C									
	143TC									
216	48CZ	3,75	4,75	0,33	0,31	5,75	7,63	13/32	7,000	29
	56C									
	143TC									
246	56C	3,61	5,00	0,33	0,25	6,00	8,30	13/32	7,500	43
	143TC									
	182TC									
266	56C	3,89	5,75	0,33	0,31	6,50	8,70	13/32	8,000	43
	143TC									
	182TC									
326	56C	4,45	6,88	0,44	0,31	7,50	10,14	13/32	9,000	74
	143TC									
	182TC									
	213TC									
386	56C	5,09	7,50	0,44	0,31	8,25	11,53	9/16	10,000	92
	143TC									
	182TC									

### Stock Output Bores

MINIMUM AND MAXIMUM BORE DIMENSIONS SHOWN.FOR ADDITIONAL STOCK OUTPUT BORE SIZES AVAILABLE SEE PAGE B-96.

MODEL	G	U (MIN.)	U (MAX.)	S	T	Z	ZT
136	48CZ	N/A	5/8	0,75	2,25	3,00	5,25
	56C						
186	48CZ	15/16	1	0,91	2,41	3,31	5,71
	56C						
	143TC						
216	48CZ	15/16	1-1/2	0,85	2,78	3,63	6,41
	56C						
	143TC						
246	56C	1	1-1/2	0,75	2,97	3,72	6,69
	143TC						
	182TC						
266	56C	1	1-1/2	0,66	2,97	3,62	6,59
	143TC						
	182TC						
326	56C	1-7/16	2-3/16	0,22	3,78	4,00	7,78
	143TC						
	182TC						
	213TC						
386	56C	1-7/16	2-3/16	0,72	3,78	4,50	8,28
	143TC						
	182TC						



Select hollow output bore models in this product line are now available with the HubLoc® keyless bushing system. Refer to pages i and ii at front of this catalog for features, available sizes, and ordering information.

EMAIL: [hubsales@regalbelloit.com](mailto:hubsales@regalbelloit.com) • [www.regalbelloit.com](http://www.regalbelloit.com)

