

Hub City™ Worm Gear Drives

Double Reduction

PowerCubeX® Worm Speed Reducer Catalog Ratings

1300 Series • 130 Primary • 130 Secondary

SERIES	INPUT RPM	UNIT RATIO	OUTPUT RPM	PRIM. RATIO	SEC. RATIO	ALL	CONVENTIONAL OIL		PAO SYNTHETIC OIL		PAG SYNTHETIC OIL	
						INPUT HP	EFF. %	OUTPUT TORQUE	EFF. %	OUTPUT TORQUE	EFF. %	OUTPUT TORQUE
1300	1750	50	35.0	5	10	0.291	63.9	335	71.8	376	76.4	400
		75	23.3	5	15	0.223	59.2	357	66.6	401	70.8	426
		100	17.5	5	20	0.176	56.1	355	63.0	399	67.0	424
		150	11.7	10	15	0.125	54.5	369	61.3	415	65.2	441
		200	8.75	10	20	0.099	51.4	366	57.8	411	61.5	437
		250	7.00	10	25	0.090	46.7	377	52.5	424	55.8	450
		300	5.83	20	15	0.071	48.5	374	54.5	420	58.0	447
		400	4.38	20	20	0.057	45.6	371	51.2	417	54.4	443
		500	3.50	25	20	0.048	42.7	371	48.0	417	51.0	443
		600	2.92	20	30	0.047	38.1	383	42.8	430	45.5	458
		750	2.33	25	30	0.040	35.5	383	39.9	430	42.4	458
		900	1.94	30	30	0.035	33.6	383	37.8	430	40.2	458
		1000	1.75	50	20	0.030	34.6	371	38.9	417	41.3	443
		1200	1.46	40	30	0.029	30.4	383	34.2	430	36.3	458
		1500	1.17	50	30	0.025	28.4	383	31.9	430	33.9	458
		1800	0.97	60	30	0.023	26.0	383	29.2	430	31.0	458
		2000	0.88	50	40	0.020	25.5	369	28.7	415	30.5	441
		2400	0.73	60	40	0.018	23.4	369	26.2	415	27.9	441
3000	0.58	60	50	0.015	21.6	346	24.2	389	25.8	413		
3600	0.49	60	60	0.014	19.0	333	21.3	374	22.7	398		

1500 Series • GW130 Primary • W150 Secondary

SERIES	INPUT RPM	UNIT RATIO	OUTPUT RPM	PRIM. RATIO	SEC. RATIO	ALL	CONVENTIONAL OIL		PAO SYNTHETIC OIL		PAG SYNTHETIC OIL	
						INPUT HP	EFF. %	OUTPUT TORQUE	EFF. %	OUTPUT TORQUE	EFF. %	OUTPUT TORQUE
1500	1750	50	35.0	5	10	0.484	61.1	533	68.7	599	73.0	637
		75	23.3	5	15	0.378	55.5	566	62.4	636	66.3	676
		100	17.5	5	20	0.310	51.5	575	57.9	646	61.5	687
		150	11.7	10	15	0.220	50.2	596	56.4	670	60.0	712
		200	8.75	10	20	0.181	46.2	604	51.9	679	55.2	722
		250	7.00	10	25	0.145	46.2	604	51.9	679	55.2	722
		300	5.83	20	15	0.128	44.1	609	49.5	684	52.6	728
		400	4.38	20	20	0.106	40.3	617	45.3	693	48.2	737
		500	3.50	25	20	0.091	37.5	617	42.2	693	44.8	737
		600	2.92	20	30	0.088	32.7	623	36.7	700	39.1	744
		750	2.33	25	30	0.076	30.4	623	34.1	700	36.3	744
		900	1.94	30	30	0.067	28.6	623	32.1	700	34.2	744
		1000	1.75	50	20	0.056	30.3	617	34.1	693	36.2	737
		1200	1.46	40	30	0.055	26.3	623	29.5	700	31.4	744
		1500	1.17	50	30	0.048	24.2	623	27.2	700	28.9	744
		1800	0.97	60	30	0.044	22.0	623	24.7	700	26.3	744
		2000	0.88	50	40	0.041	21.0	613	23.6	689	25.1	732
		2400	0.73	60	40	0.037	19.1	613	21.5	689	22.8	732
3000	0.58	60	50	0.033	16.9	592	18.9	665	20.1	707		
3600	0.49	60	60	0.029	15.1	560	16.9	629	18.0	669		

ADDITIONAL RATINGS FOR OTHER INPUT SPEEDS ARE AVAILABLE AT: WWW.HUBCITYINC.COM

OVERHUNG LOAD AND THRUST LOAD INFORMATION

OVERHUNG LOAD - LOW SPEED SHAFT — MODELS 1301 AND 1304 225 LBS. AT CENTER POINT OF SHAFT EXTENSION.

OVERHUNG LOAD - LOW SPEED SHAFT — MODELS 1501 AND 1504 860 LBS. AT CENTER POINT OF SHAFT EXTENSION. MODELS 1502 AND 1505 NOT APPLICABLE. THRUST± UP OR DOWN 790 LBS.

±OHL AND THRUST VALUES SHOWN ARE INDEPENDENT FUNCTIONS AND CANNOT BE APPLIED SIMULTANEOUSLY. REFER APPLICATIONS WITH COMBINED OHL AND THRUST TO REGAL CUSTOMER SERVICE DEPARTMENT.

OUTPUT TORQUE VALUES SHOWN ARE INCH-POUNDS (IN-LB).

Hub City™ Worm Gear Drives

Double Reduction Models

1304, 1504, 1804, 2104, 2404, 2604, 3004, 3204, 3804, 4204, 4504, 5204, GW6004, GW7004, GW8004, GW10004

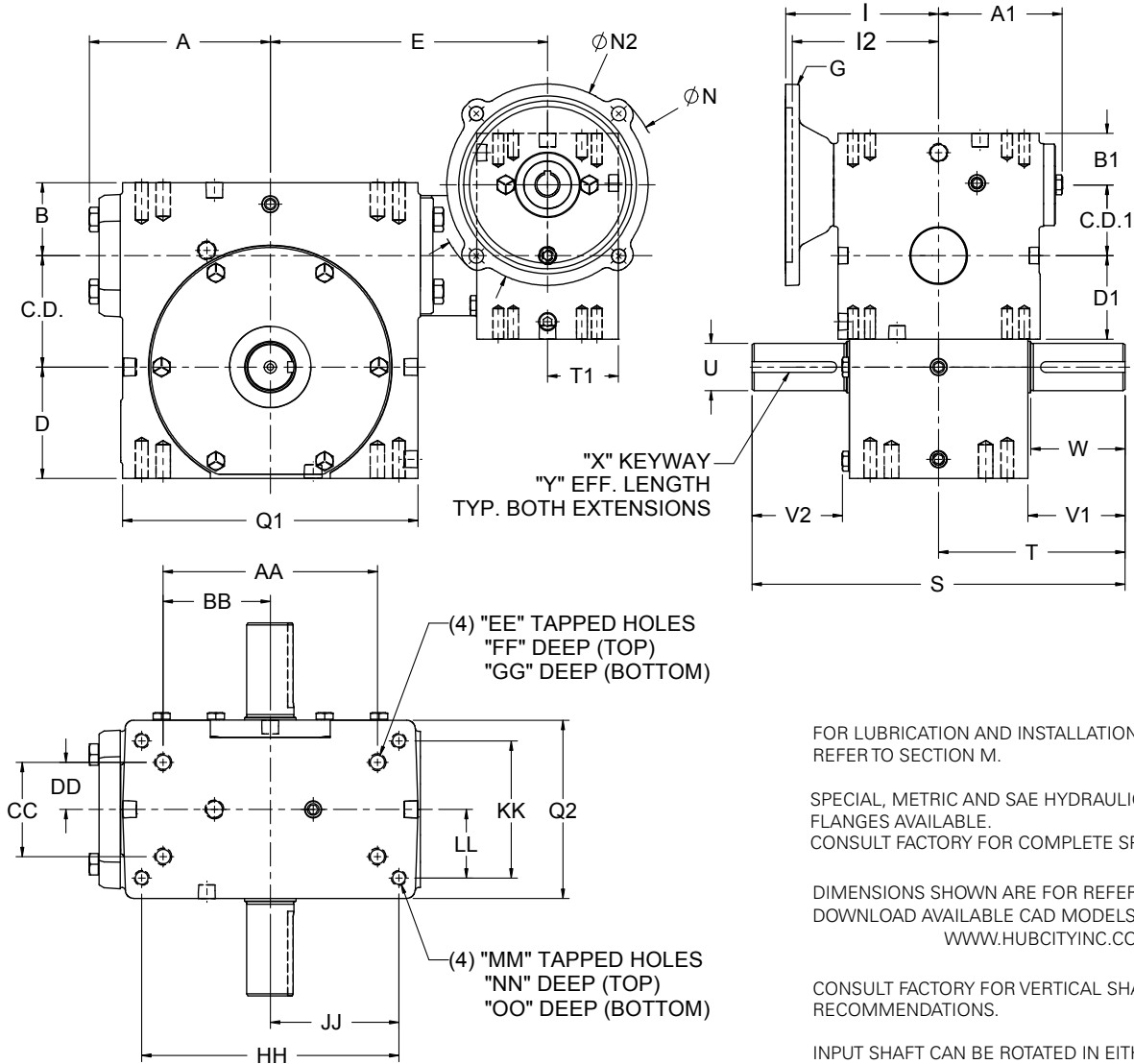

FOR LUBRICATION AND INSTALLATION INSTRUCTIONS REFER TO SECTION M.

SPECIAL, METRIC AND SAE HYDRAULIC INPUT FLANGES AVAILABLE. CONSULT FACTORY FOR COMPLETE SPECIFICATIONS.

DIMENSIONS SHOWN ARE FOR REFERENCE ONLY. DOWNLOAD AVAILABLE CAD MODELS AT: WWW.HUBCITYINC.COM

CONSULT FACTORY FOR VERTICAL SHAFT LUBRICATION RECOMMENDATIONS.

INPUT SHAFT CAN BE ROTATED IN EITHER DIRECTION.

Standard Styles Available

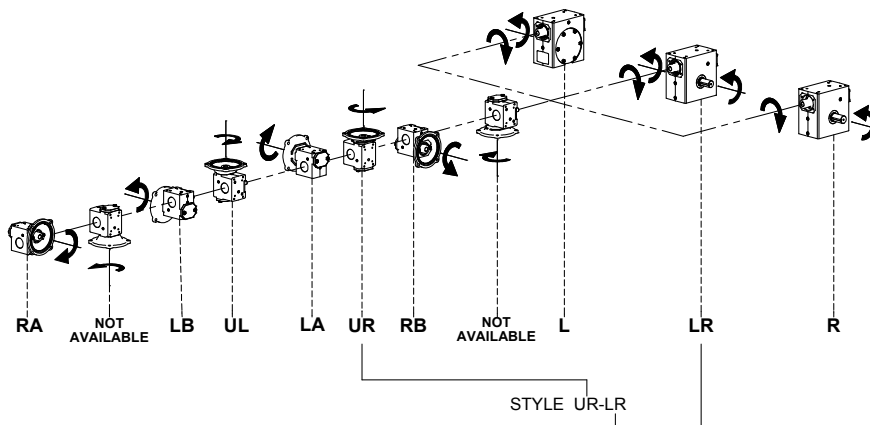

Hub City™ Worm Gear Drives

Double Reduction Models

1304, 1504, 1804, 2104, 2404, 2604, 3004, 3204, 3804, 4204, 4504, 5204, GW6004, GW7004, GW8004, GW10004

MODEL	PRIMARY	SECONDARY	C.D.	A	B	D	Q1	Q2	E	T1	C.D.1	A1	B1	D1	S	T
1304	134	134-56C	1.334	2.61	1.186	1.562	4.12	3.12	4.87	1.56	1.334	2.61	1.186	1.562	6.50	3.25
1504	GW134	154	1.541	3.14	1.928	1.906	4.88	3.44	5.85	1.84	1.334	2.61	1.610	1.720	8.62	4.31
1804	134	184-56C	1.751	3.23	1.374	1.875	5.16	3.44	5.50	1.56	1.334	2.61	1.186	1.562	7.00	3.50
2104	134	214-56C	2.064	3.61	1.500	2.437	5.88	4.12	5.87	1.56	1.334	2.61	1.186	1.562	8.50	4.25
2404	GW134	244	2.376	3.77	2.061	2.500	6.12	4.06	6.44	1.84	1.334	2.61	1.610	1.720	10.28	5.14
2604	134	264-56C	2.626	4.33	1.874	2.938	7.20	4.50	6.58	1.56	1.334	2.61	1.186	1.562	9.00	4.50
3004	GW184	304	3.001	4.84	2.624	3.250	8.12	5.25	7.86	1.78	1.750	3.24	1.940	2.060	13.50	6.75
3204	214	324-143TC	3.251	5.28	2.124	3.250	8.62	5.20	8.09	2.06	2.064	3.61	1.500	2.437	10.88	5.44
3804	214	384-143TC	3.751	4.90	2.374	3.937	9.60	5.62	8.61	2.06	2.064	3.61	1.500	2.437	13.38	6.69
4204	GW214	424	4.251	6.10	2.686	4.438	10.25	6.13	9.18	1.91	2.060	3.61	2.020	2.280	16.24	8.12
4504	324	454-213TC	4.501	5.23	2.499	4.625	9.25	4.63	9.14	2.60	3.251	5.28	2.124	3.250	14.50	7.25
5204	324	524-213TC	5.168	5.98	2.624	5.375	10.75	5.06	9.89	2.60	3.251	5.28	2.124	3.250	15.62	7.81
GW6004	GW324	GW601	6.000	N/A	4.000	6.500	14.25	8.13	13.30	2.88	3.250	5.02	2.630	3.500	20.00	10.00
GW7004	GW324	GW701	7.000	N/A	4.320	7.590	14.88	7.63	12.96	2.88	3.250	5.02	2.630	3.500	23.52	11.76
GW8004	GW424	GW801	8.000	N/A	4.100	8.860	17.00	8.63	13.94	3.07	4.250	6.10	2.690	4.440	24.50	12.25
GW10004	GW454	GW1001	10.000	N/A	5.110	10.360	20.88	9.53	17.05	3.60	5.250	7.50	3.630	5.120	29.50	14.75

MODEL	U	V1	V2	W	X	Y
1304	.625/.624	1.69	1.53	1.60	3/16 X 3/32	1.38
1504	.750/.7485	2.11	1.90	2.08	3/16 X 3/32	1.51
1804	.750/.749	1.78	1.57	1.54	3/16 X 3/32	1.41
2104	.875/.874	2.19	1.98	1.95	3/16 X 3/32	1.83
2404	1.125/1.1235	2.66	2.44	2.62	1/4 X 1/8	1.76
2604	1.250/1.249	2.25	2.04	N/A	1/4 X 1/8	1.85
3004	1.250/1.2485	3.60	3.36	3.57	1/4 X 1/8	2.26
3204	1.375/1.374	2.84	2.62	2.75	5/16 X 5/32	2.31
3804	1.500/1.499	3.88	N/A	N/A	3/8 X 3/16	3.16

MODEL	U	V1	V2	W	X	Y
4204	1.875/1.8735	4.50	4.21	4.47	1/2 X 1/4	3.06
4504**	1.625/1.624	4.18	N/A	3.90	3/8 X 3/16	3.28
5204***	1.750/1.749	4.47	N/A	4.17	3/8 X 3/16	3.50
GW6004	2.500	4.65	4.65	N/A	5/8 X 5/16 P&W	4.00
GW7004	2.750	5.65	5.65	N/A	5/8 X 5/16 P&W	4.00
GW8004	3.000	5.98	5.98	5.26	3/4 X 3/8 P&W	4.50
GW10004	3.750	6.76	6.76	6.39	7/8 X 7/16 P&W	5.00

** ALSO AVAILABLE WITH 1.750/1.749 (U) DIAMETER OUTPUT SHAFT. CONSULT FACTORY.
 *** ALSO AVAILABLE WITH 2.000/1.999 (U) DIAMETER OUTPUT SHAFT. CONSULT FACTORY.

MODEL	AA	BB	CC	DD	EE	FF	GG	HH	JJ	KK	LL	MM	NN	OO	WT. LBS.
1304	2.250	1.125	1.625	0.813	1/4 UNC	0.50	0.50	3.250	1.625	2.000	1.000	5/16 UNC	0.50	0.50	22
1504	4.188	2.094	2.750	1.375	5/16 UNC	0.63	0.63	N/A	N/A	N/A	N/A	N/A	N/A	N/A	26
1804	3.125	1.563	1.625	0.813	1/4 UNC	0.50	0.50	4.188	2.094	2.750	1.375	5/16 UNC	0.63	0.63	26
2104	4.000	2.000	2.000	1.000	3/8 UNC	0.50	0.70	5.000	2.500	2.875	1.438	3/8 UNC	0.70	0.70	36
2404	5.000	2.500	2.875	1.438	3/8 UNC	0.69	0.69	N/A	N/A	N/A	N/A	N/A	N/A	N/A	52
2604	4.875	2.438	2.688	1.344	3/8 UNC	0.70	0.70	6.375	3.188	3.375	1.688	3/8 UNC	0.70	0.70	48
3004	7.000	3.500	4.000	2.000	7/16 UNC	0.88	0.88	N/A	N/A	N/A	N/A	N/A	N/A	N/A	81
3204	6.250	3.125	2.750	1.375	1/2 UNC	0.75	0.75	7.500	3.750	4.000	2.000	7/16 UNC	0.88	0.88	85
3804	6.875	3.438	3.000	1.500	1/2 UNC	0.94	1.00	8.500	4.250	4.750	2.375	1/2 UNC	1.00	1.00	115
4204	8.500	4.250	5.000	2.500	5/8 UNC	1.00	1.00	N/A	N/A	N/A	N/A	N/A	N/A	N/A	135
4504	8.125	4.063	3.250	1.625	5/8 UNC	0.88	1.13	N/A	N/A	N/A	N/A	N/A	N/A	N/A	176
5204	9.500	4.750	3.750	1.875	5/8 UNC	1.00	1.25	N/A	N/A	N/A	N/A	N/A	N/A	N/A	202
GW6004	12.750	6.375	6.380	3.190	5/8 UNC	1.00	1.00	N/A	N/A	N/A	N/A	N/A	N/A	N/A	406
GW7004	12.500	6.250	5.500	2.750	1 UNC	1.56	1.56	N/A	N/A	N/A	N/A	N/A	N/A	N/A	482
GW8004	14.250	7.125	6.500	3.250	1 UNC	1.66	1.66	N/A	N/A	N/A	N/A	N/A	N/A	N/A	728
GW10004	17.750	8.875	6.875	3.438	1-1/4 UNC	2.04	2.04	N/A	N/A	N/A	N/A	N/A	N/A	N/A	1151

MODEL	G	I	I2	N	N2
1304	48CZ	3.46	N/A	4.36	3.87
	56C			6.63	6.50
1504	48CZ	3.46	N/A	4.36	3.87
	56C			6.63	6.50
1804	48CZ	3.46	N/A	4.36	3.87
	56C			6.63	6.50
2104	48CZ	3.46	N/A	4.36	3.87
	56C			6.63	6.50
2404	48CZ	3.46	N/A	4.36	3.87
	56C			6.63	6.50
2604	48CZ	3.46	N/A	4.36	3.87
	56C			6.63	6.50
3004	48CZ	4.09	N/A	4.36	3.87
	56C			6.63	6.50
	143TC			6.63	6.50

MODEL	G	I	I2	N	N2
3204	48CZ	4.46	N/A	4.36	3.87
	56C			6.63	6.50
3804	143TC				
	48CZ	4.46	N/A	4.36	3.87
56C	6.63			6.50	
4204	143TC				
	48CZ	4.46	N/A	4.36	3.87
56C	6.63			6.50	
4504	143TC				
	56C	6.14	N/A	6.50	6.50
143TC					
5204	182TC	N/A	6.34	9.00	9.00
	213TC				
5204	56C	6.14	N/A	6.50	6.50
	143TC				
5204	182TC	N/A	6.34	9.00	9.00
	213TC				

MODEL	G	I	I2	N	N2
GW6004	56C	6.14	N/A	6.50	6.50
	143TC				
	182TC	N/A	6.34	9.00	9.00
213TC	6.90				
GW7004	56C	6.14	N/A	6.50	6.50
	143TC				
	182TC	N/A	6.34	9.00	9.00
213TC	6.90				
GW8004	56C	6.45	N/A	6.50	6.50
	143TC				
	182TC	N/A	7.21	9.00	9.00
	213TC				
254TC					
GW10004	56C	7.85	N/A	6.50	6.50
	143TC				
	182TC	N/A	8.61	9.00	9.00
	213TC				
	254TC	N/A	9.17		