

Hub City™ Worm Gear Drives

Single Reduction

PowerCubeX® Worm Speed Reducer Catalog Ratings

Series 300

SERIES	INPUT RPM	RATIO	OUTPUT RPM	CONVENTIONAL OIL					PAO SYNTHETIC OIL			PAG SYNTHETIC OIL		
				MECH. INPUT HP	EFF. %	MECH. OUTPUT TORQUE	THERMAL INPUT HP	THERMAL OUTPUT TORQUE	INPUT HP	EFF. %	OUTPUT TORQUE	INPUT HP	EFF. %	OUTPUT TORQUE
300	2500	5	500	9.20	87.8	1018	7.01	776	9.20	93.1	1080	9.20	96.0	1113
		7.5	333	7.49	86.8	1229	6.62	1087	7.49	92.0	1303	7.49	94.9	1343
		10	250	6.75	86.0	1463	4.33	939	6.75	91.1	1551	6.75	93.9	1599
		15	167	5.36	84.0	1705	3.39	1078	5.36	89.1	1807	5.36	91.8	1863
		20	125	4.52	82.1	1872	2.76	1144	4.52	87.1	1985	4.52	89.8	2046
		25	100	3.87	80.4	1959	2.35	1191	3.87	85.2	2076	3.87	87.9	2141
		30	83.3	3.43	78.6	2040	1.93	1145	3.43	83.3	2162	3.43	85.9	2229
		40	62.5	2.68	74.8	2020	1.58	1194	2.68	79.3	2141	2.68	81.8	2208
		50	50.0	2.16	72.0	1962	1.39	1260	2.16	76.3	2080	2.16	78.6	2144
		60	41.7	1.78	69.0	1863	1.22	1278	1.78	73.2	1975	1.78	75.4	2036
	80	31.3	1.14	65.6	1501	1.10	1449	1.14	69.5	1591	1.14	71.7	1641	
	100	25.0	0.76	61.8	1188	0.74	1152	0.76	65.5	1259	0.76	67.6	1298	
	1750	5	350	7.96	87.1	1249	6.79	1065	7.96	92.4	1324	7.96	95.2	1365
		7.5	233	6.33	86.0	1471	6.33	1470	6.33	91.2	1560	6.33	94.0	1608
		10	175	5.79	85.0	1774	4.16	1274	5.79	90.1	1880	5.79	92.9	1939
		15	117	4.64	82.7	2074	3.23	1445	4.64	87.7	2199	4.64	90.4	2267
		20	87.5	3.92	80.6	2277	2.64	1533	3.92	85.4	2414	3.92	88.1	2488
		25	70.0	3.37	78.6	2385	2.26	1596	3.37	83.3	2528	3.37	85.9	2606
		30	58.3	3.00	76.5	2484	1.84	1521	3.00	81.1	2633	3.00	83.7	2714
		40	43.8	2.36	72.3	2458	1.52	1581	2.36	76.7	2606	2.36	79.0	2686
		50	35.0	1.92	69.2	2389	1.32	1642	1.92	73.3	2533	1.92	75.6	2611
		60	29.2	1.59	66.0	2269	1.17	1664	1.59	70.0	2405	1.59	72.1	2480
	80	21.9	1.04	62.3	1870	THERMAL EQUALS MECHANICAL		1.04	66.0	1982	1.04	68.1	2044	
	100	17.5	0.70	58.3	1466	THERMAL EQUALS MECHANICAL		0.70	61.8	1554	0.70	63.7	1603	
	1170	5	234	6.70	86.3	1556	6.04	1403	6.70	91.5	1650	6.70	94.3	1701
		7.5	156	5.45	84.9	1870	5.39	1849	5.45	90.0	1982	5.45	92.8	2043
		10	117	4.87	83.7	2197	3.92	1767	4.87	88.8	2329	4.87	91.5	2401
		15	78.0	3.86	81.1	2532	3.11	2042	3.86	86.0	2684	3.86	88.7	2767
		20	58.5	3.29	78.6	2787	2.48	2097	3.29	83.3	2955	3.29	85.9	3046
		25	46.8	2.82	76.4	2898	2.18	2239	2.82	81.0	3072	2.82	83.5	3167
		30	39.0	2.52	74.0	3015	1.79	2145	2.52	78.5	3197	2.52	80.9	3295
		40	29.3	2.01	69.3	3000	1.52	2266	2.01	73.5	3181	2.01	75.8	3279
		50	23.4	1.63	65.9	2897	1.35	2405	1.63	69.8	3071	1.63	72.0	3166
		60	19.5	1.36	62.4	2751	1.22	2470	1.36	66.2	2916	1.36	68.2	3006
	80	14.6	0.88	58.5	2216	THERMAL EQUALS MECHANICAL		0.88	62.0	2350	0.88	63.9	2422	
	100	11.7	0.59	54.4	1726	THERMAL EQUALS MECHANICAL		0.59	57.6	1830	0.59	59.4	1886	
	100	5	20.0	0.99	80.2	2493	THERMAL EQUALS MECHANICAL		0.99	85.0	2642	0.99	87.6	2724
		7.5	13.3	0.79	77.6	2909	THERMAL EQUALS MECHANICAL		0.79	82.3	3084	0.79	84.9	3180
		10	10.0	0.68	75.8	3261	THERMAL EQUALS MECHANICAL		0.68	80.4	3457	0.68	82.9	3564
		15	6.7	0.54	71.5	3659	THERMAL EQUALS MECHANICAL		0.54	75.8	3879	0.54	78.1	3999
		20	5.0	0.48	67.3	4049	THERMAL EQUALS MECHANICAL		0.48	71.3	4292	0.48	73.5	4425
		25	4.0	0.41	64.0	4151	THERMAL EQUALS MECHANICAL		0.41	67.8	4400	0.41	69.9	4536
		30	3.3	0.38	60.5	4313	THERMAL EQUALS MECHANICAL		0.38	64.1	4572	0.38	66.1	4713
		40	2.5	0.32	53.8	4334	THERMAL EQUALS MECHANICAL		0.32	57.0	4595	0.32	58.8	4737
		50	2.0	0.26	49.6	4134	THERMAL EQUALS MECHANICAL		0.26	52.6	4383	0.26	54.2	4518
60		1.7	0.228	45.5	3924	THERMAL EQUALS MECHANICAL		0.228	48.2	4160	0.228	49.7	4288	
80	1.3	0.144	41.9	3033	THERMAL EQUALS MECHANICAL		0.144	44.4	3215	0.144	45.8	3314		
100	1.0	0.098	37.8	2332	THERMAL EQUALS MECHANICAL		0.098	40.1	2472	0.098	41.3	2548		

ADDITIONAL RATINGS FOR OTHER INPUT SPEEDS ARE AVAILABLE AT WWW.REGALBELOIT.COM

OVERHUNG LOAD AND THRUST LOAD INFORMATION

OVERHUNG LOAD - LOW SPEED SHAFT — MODELS 301 AND 304 1,150 LBS. AT CENTER POINT OF SHAFT EXTENSION. MODELS 302 AND 305 NOT APPLICABLE. THRUST± UP OR DOWN 1,725 LBS.

± OHL AND THRUST VALUES SHOWN ARE INDEPENDENT FUNCTIONS AND CANNOT BE APPLIED SIMULTANEOUSLY. REFER APPLICATIONS WITH COMBINED OHL AND THRUST TO REGAL CUSTOMER SERVICE DEPARTMENT.

OUTPUT TORQUE VALUES SHOWN ARE INCH-POUNDS (IN-LB).

Hub City™ Worm Gear Drives

Single Reduction Models

133, 183, 213, 243, 263, 323, 383 (STEEL BRACKET)

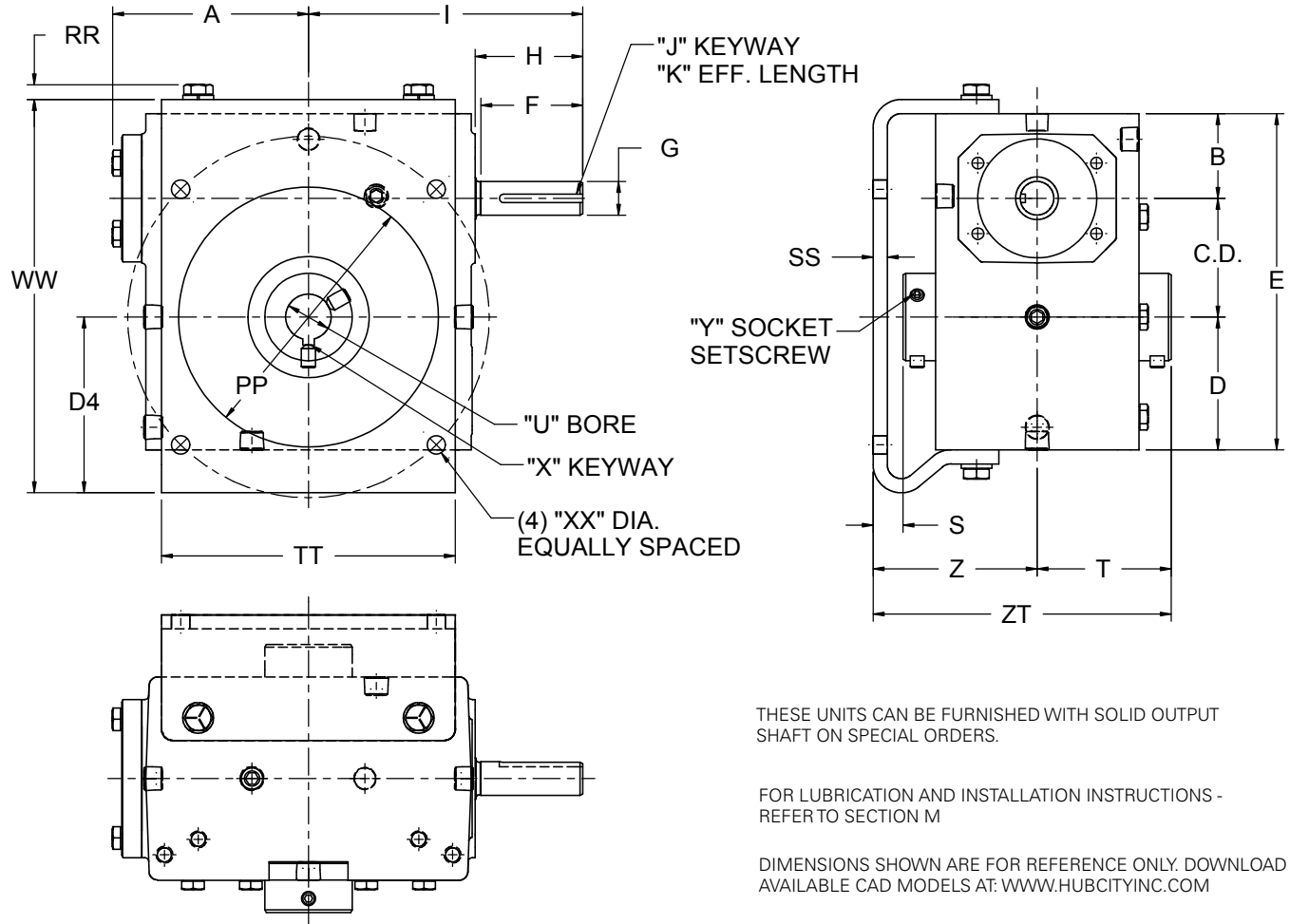

Standard Styles Available

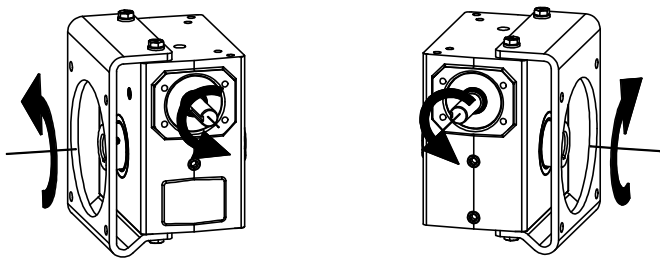

STYLE "L"

STYLE "R"

CONSULT FACTORY FOR VERTICAL SHAFT LUBRICATION RECOMMENDATIONS.
INPUT SHAFT CAN BE ROTATED IN EITHER DIRECTION.

Hub City™ Worm Gear Drives

Single Reduction Models

133, 183, 213, 243, 263, 323, 383 (STEEL BRACKET)

MODEL	C.D.	A	B	D	E	F	G	H	I	J	K
133	1.334	2.61	1.186	1.562	4.082	1.67	.500/.4985	1.76	3.82	1/8 X 1/16 P&W	1.44
183	1.751	3.23	1.374	1.875	5.000	N/A	.625/.6235	1.76	4.44	3/16 X 3/32 P&W	1.50
213	2.064	3.61	1.500	2.437	6.000	N/A	.625/.6235	1.76	4.82	3/16 X 3/32 P&W	1.50
243 *	2.376	3.77	2.061	2.500	6.937	2.38	.750/.7485	2.38	5.51	3/16 X 3/32 P&W	1.75
263	2.626	4.33	1.874	2.938	7.438	2.36	.750/.7485	2.38	6.07	3/16 X 3/32 P&W	1.75
323	3.251	5.28	2.124	3.250	8.625	N/A	.875/.8735	2.38	6.75	3/16 X 3/32 P&W	1.75
383	3.751	4.90	2.374	3.937	10.062	2.20	1.000/.999	2.48	7.38	1/4 X 1/8 P&W	1.91

* Model 243 also available with cast F-flange as either an add-on kit (see page B-103) or as a special assembly (consult factory).

MODEL	D4	PP	RR	SS	TT	WW	XX	YY	Wt. Lbs.
133	2.50	3.62	0.22	0.19	4.25	5.22	11/32	5.000	18
183	3.13	4.25	0.22	0.25	4.88	6.50	11/32	5.875	18
213	3.75	4.75	0.33	0.31	5.75	7.63	13/32	7.000	29
243	3.61	5.00	0.33	0.25	6.00	8.30	13/32	7.500	43
263	3.89	5.75	0.33	0.31	6.75	8.70	13/32	8.000	43
323	4.45	6.88	0.44	0.31	7.50	10.14	13/32	9.000	74
383	5.09	7.50	0.44	0.31	8.25	11.53	9/16	10.000	92

Stock Output Bores

MINIMUM AND MAXIMUM BORE DIMENSIONS SHOWN.
FOR ADDITIONAL STOCK OUTPUT BORE SIZES
AVAILABLE SEE PAGE B-96.

MODEL	U (MIN.)	U (MAX.)	S	T	Z	ZT
133	N/A	5/8	0.75	2.25	3.00	5.25
183	15/16	1	0.91	2.41	3.31	5.71
213	15/16	1-1/2	0.85	2.78	3.63	6.41
243	1	1-1/2	0.75	2.97	3.72	6.69
263	1	1-1/2	0.66	2.97	3.63	6.60
323	1-7/16	2-3/16	0.22	3.78	4.00	7.78
383	1-7/16	2-3/16	0.72	3.78	4.50	8.28

BORE TOLERANCE NOMINAL + .002



Select hollow output bore models in this product line are now available with the HubLoc® keyless bushing system. Refer to pages i and ii at front of this catalog for features, available sizes, and ordering information.