

Hub City™ Worm Gear Drives

Single Reduction

PowerCubeX® Worm Speed Reducer Catalog Ratings

Series 260

SERIES	INPUT RPM	RATIO	OUTPUT RPM	CONVENTIONAL OIL					PAO SYNTHETIC OIL			PAG SYNTHETIC OIL		
				MECH. INPUT HP	EFF. %	MECH. OUTPUT TORQUE	THERMAL INPUT HP	THERMAL OUTPUT TORQUE	INPUT HP	EFF. %	OUTPUT TORQUE	INPUT HP	EFF. %	OUTPUT TORQUE
260	2500	5	500	8.61	87.4	948	4.30	473	8.61	92.6	1005	8.61	95.5	1037
		7.5	333	6.68	86.6	1095	3.70	607	6.68	91.8	1160	6.68	94.7	1196
		10	250	5.64	85.8	1220	3.65	790	5.64	91.0	1293	5.64	93.8	1333
		15	167	4.03	84.4	1288	2.30	735	4.03	89.5	1365	4.03	92.2	1407
		20	125	3.21	82.1	1329	2.47	1023	3.21	87.0	1409	3.21	89.7	1453
		25	100	2.65	80.5	1345	2.25	1142	2.65	85.3	1426	2.65	88.0	1470
		30	83.3	2.26	79.0	1350	1.36	812	2.26	83.7	1431	2.26	86.3	1476
		40	62.5	1.77	74.8	1336	1.38	1042	1.77	79.3	1417	1.77	81.8	1460
		50	50.0	1.43	72.2	1302	1.35	1229	1.43	76.5	1380	1.43	78.9	1422
		60	41.7	1.17	69.7	1236	0.89	940	1.17	73.9	1311	1.17	76.2	1351
	80	31.3	0.77	65.8	1021	0.67	888	0.77	69.8	1082	0.77	72.0	1116	
	100	25.0	0.51	62.1	801	0.45	707	0.51	65.9	849	0.51	67.9	876	
	1750	5	350	7.35	86.7	1147	4.21	657	7.35	91.9	1216	7.35	94.7	1254
		7.5	233	5.73	85.8	1327	3.62	838	5.73	90.9	1407	5.73	93.7	1450
		10	175	5.00	84.8	1485	3.55	1054	5.00	89.9	1575	5.00	92.7	1623
		15	117	3.49	83.2	1570	2.20	990	3.49	88.2	1664	3.49	90.9	1716
		20	87.5	2.83	80.6	1640	2.37	1373	2.83	85.4	1738	2.83	88.0	1792
		25	70.0	2.31	78.7	1640	2.12	1505	2.31	83.5	1739	2.31	86.1	1793
		30	58.3	2.00	77.0	1634	1.29	1054	2.00	81.7	1732	2.00	84.2	1785
		40	43.8	1.58	72.4	1642	1.31	1361	1.58	76.7	1741	1.58	79.1	1795
		50	35.0	1.27	69.5	1583	1.27	1583	1.27	73.6	1678	1.27	75.9	1730
		60	29.2	1.03	66.8	1493	0.84	1218	1.03	70.8	1583	1.03	73.0	1632
	80	21.9	0.67	62.7	1212	0.59	1067	0.67	66.4	1285	0.67	68.5	1325	
	100	17.5	0.45	58.7	945	0.40	840	0.45	62.3	1001	0.45	64.2	1032	
	1170	5	234	6.19	85.7	1429	3.81	880	6.19	90.9	1515	6.19	93.7	1562
		7.5	156	4.81	84.7	1644	3.25	1111	4.81	89.8	1743	4.81	92.5	1796
		10	117	3.98	83.6	1792	3.20	1441	3.98	88.6	1899	3.98	91.3	1958
		15	78.0	2.77	81.7	1830	2.12	1401	2.77	86.6	1940	2.77	89.3	2000
		20	58.5	2.28	78.7	1929	2.26	1912	2.28	83.4	2045	2.28	86.0	2108
		25	46.8	1.85	76.6	1912	1.85	1912	1.85	81.3	2027	1.85	83.8	2090
		30	39.0	1.57	74.7	1893	1.27	1531	1.57	79.2	2007	1.57	81.7	2069
		40	29.3	1.29	69.5	1926			1.29	73.7	2042	1.29	76.0	2105
		50	23.4	1.03	66.3	1842			1.03	70.3	1952	1.03	72.5	2013
		60	19.5	0.84	63.5	1728			0.84	67.3	1832	0.84	69.4	1888
	100	80	14.6	0.54	59.1	1384			0.54	62.7	1468	0.54	64.6	1513
		100	11.7	0.36	55.0	1073			0.36	58.3	1138	0.36	60.1	1173
		5	20.0	0.86	79.4	2144			0.86	84.2	2273	0.86	86.8	2344
		7.5	13.3	0.67	77.6	2439			0.67	82.2	2586	0.67	84.8	2666
		10	10.0	0.53	76.0	2531			0.53	80.5	2683	0.53	83.0	2766
		15	6.7	0.35	73.5	2429			0.35	77.9	2575	0.35	80.3	2654
20		5.0	0.30	68.3	2604			0.30	72.5	2760	0.30	74.7	2846	
25		4.0	0.246	65.5	2538			0.246	69.4	2691	0.246	71.6	2774	
30		3.3	0.209	62.9	2485			0.209	66.7	2634	0.209	68.7	2716	
40		2.5	0.185	55.3	2585			0.185	58.6	2741	0.185	60.4	2826	
50	2.0	0.150	51.6	2435			0.150	54.7	2581	0.150	56.4	2661		
60	1.7	0.124	48.3	2261			0.124	51.2	2397	0.124	52.8	2471		
80	1.3	0.080	44.0	1769			0.080	46.6	1875	0.080	48.0	1933		
100	1.0	0.054	39.9	1357			0.054	42.2	1439	0.054	43.6	1484		

Worm Gear Drives



ADDITIONAL RATINGS FOR OTHER INPUT SPEEDS ARE AVAILABLE AT WWW.REGALBELOIT.COM

OVERHUNG LOAD AND THRUST LOAD INFORMATION

OVERHUNG LOAD - LOW SPEED SHAFT — MODELS 261 AND 264 1150 LBS. AT CENTER POINT OF SHAFT EXTENSION. MODELS 262 AND 265 NOT APPLICABLE. THRUST± UP OR DOWN 1000 LBS.

±OHL AND THRUST VALUES SHOWN ARE INDEPENDENT FUNCTIONS AND CANNOT BE APPLIED SIMULTANEOUSLY. REFER APPLICATIONS WITH COMBINED OHL AND THRUST TO REGAL CUSTOMER SERVICE DEPARTMENT.

OUTPUT TORQUE VALUES SHOWN ARE INCH-POUNDS (IN-LB).

Hub City™ Worm Gear Drives

Single Reduction Models

136, 186, 216, 246, 266, 326, 386 (STEEL BRACKET)

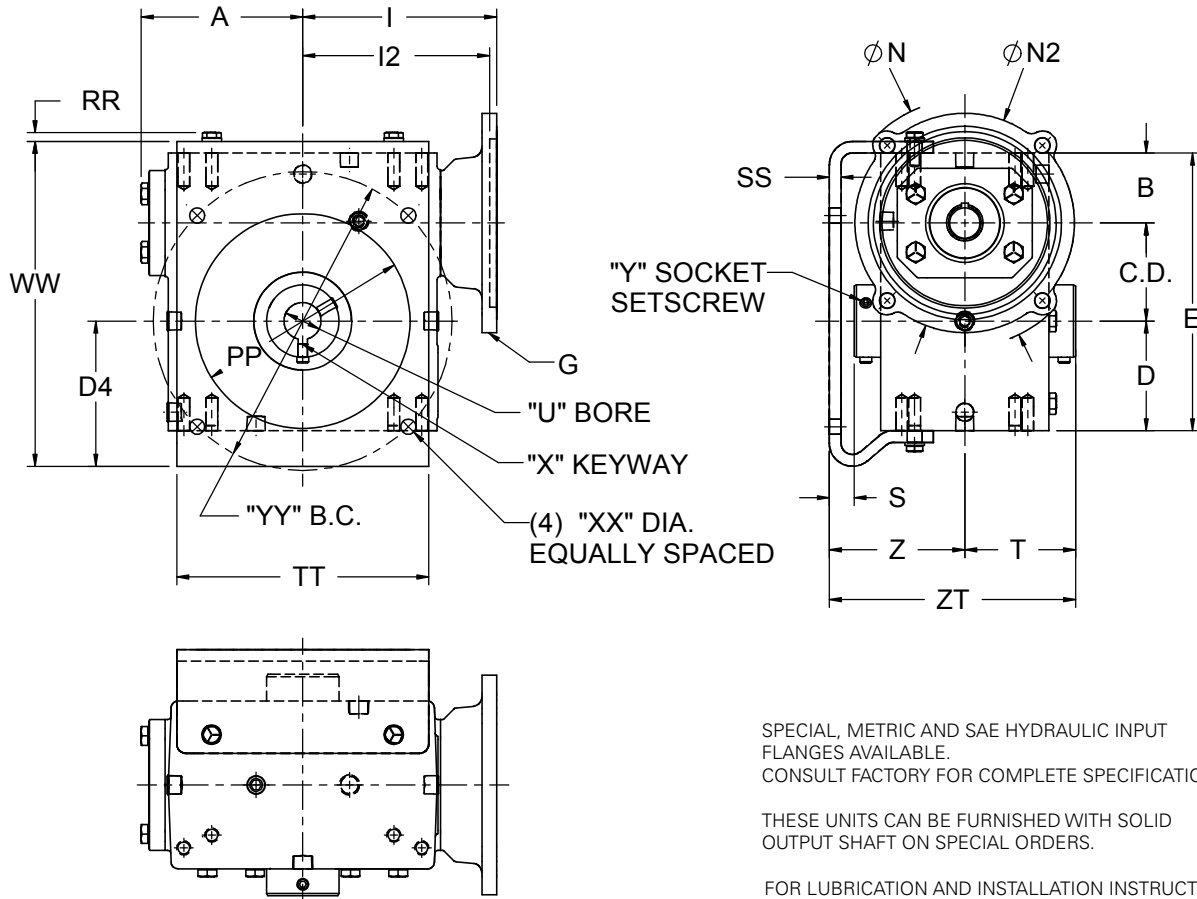

SPECIAL, METRIC AND SAE HYDRAULIC INPUT FLANGES AVAILABLE. CONSULT FACTORY FOR COMPLETE SPECIFICATIONS.

THESE UNITS CAN BE FURNISHED WITH SOLID OUTPUT SHAFT ON SPECIAL ORDERS.

FOR LUBRICATION AND INSTALLATION INSTRUCTIONS - REFER TO SECTION M

DIMENSIONS SHOWN ARE FOR REFERENCE ONLY. DOWNLOAD AVAILABLE CAD MODELS AT: WWW.HUBCITYINC.COM

Standard Styles Available

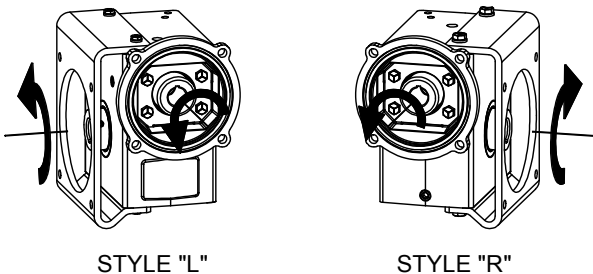

CONSULT FACTORY FOR VERTICAL SHAFT LUBRICATION RECOMMENDATIONS. INPUT SHAFT CAN BE ROTATED IN EITHER DIRECTION.

Hub City™ Worm Gear Drives

Single Reduction Models

136, 186, 216, 246, 266, 326, 386 (STEEL BRACKET)

MODEL	C.D.	A	B	D	E	G	I	I2	N	N2		
136	1.334	2.61	1.186	1.562	4.082	48CZ	3.46	N/A	4.36	3.87		
						56C			6.63	6.50		
186	1.751	3.23	1.374	1.875	5.000	48CZ	4.09	N/A	4.36	3.87		
						56C			6.63	6.50		
						143TC			6.63	6.50		
216	2.064	3.61	1.500	2.437	6.000	48CZ	4.46	N/A	4.36	3.87		
						56C			6.63	6.50		
						143TC			6.63	6.50		
246 *	2.376	3.77	2.061	2.500	6.937	56C	4.63	N/A	6.50	6.50		
						143TC			6.50	6.50		
						182TC			N/A	5.06	9.00	9.00
266	2.626	4.33	1.874	2.938	7.438	56C	5.19	N/A	6.50	6.50		
						143TC			6.50	6.50		
						182TC			N/A	5.81	9.00	9.00
326	3.251	5.28	2.124	3.250	8.625	56C	6.14	N/A	6.50	6.50		
						143TC			6.50	6.50		
						182TC			N/A	6.34	9.00	9.00
						213TC			N/A	6.90	9.00	9.00
386	3.751	4.90	2.374	3.937	10.062	56C	6.50	N/A	6.50	6.50		
						143TC			6.50	6.50		
						182TC			N/A	6.88	9.00	9.00

* Model 246 also available with cast F-flange as either an add-on kit (see page B-103) or as a special assembly (consult factory).

MODEL	G	D4	PP	RR	SS	TT	WW	XX	YY	Wt. Lbs.
136	48CZ	2,50	3,62	0,22	0,19	4,25	5,22	11/32	5,000	18
	56C									
186	48CZ	3,13	4,25	0,22	0,25	4,88	6,50	11/32	5,875	18
	56C									
	143TC									
216	48CZ	3,75	4,75	0,33	0,31	5,75	7,63	13/32	7,000	29
	56C									
	143TC									
246	56C	3,61	5,00	0,33	0,25	6,00	8,30	13/32	7,500	43
	143TC									
	182TC									
266	56C	3,89	5,75	0,33	0,31	6,50	8,70	13/32	8,000	43
	143TC									
	182TC									
326	56C	4,45	6,88	0,44	0,31	7,50	10,14	13/32	9,000	74
	143TC									
	182TC									
	213TC									
386	56C	5,09	7,50	0,44	0,31	8,25	11,53	9/16	10,000	92
	143TC									
	182TC									

Stock Output Bores

MINIMUM AND MAXIMUM BORE DIMENSIONS SHOWN.FOR ADDITIONAL STOCK OUTPUT BORE SIZES AVAILABLE SEE PAGE B-96.

MODEL	G	U (MIN.)	U (MAX.)	S	T	Z	ZT
136	48CZ	N/A	5/8	0,75	2,25	3,00	5,25
	56C						
186	48CZ	15/16	1	0,91	2,41	3,31	5,71
	56C						
	143TC						
216	48CZ	15/16	1-1/2	0,85	2,78	3,63	6,41
	56C						
	143TC						
246	56C	1	1-1/2	0,75	2,97	3,72	6,69
	143TC						
	182TC						
266	56C	1	1-1/2	0,66	2,97	3,62	6,59
	143TC						
	182TC						
326	56C	1-7/16	2-3/16	0,22	3,78	4,00	7,78
	143TC						
	182TC						
	213TC						
386	56C	1-7/16	2-3/16	0,72	3,78	4,50	8,28
	143TC						
	182TC						



Select hollow output bore models in this product line are now available with the HubLoc® keyless bushing system. Refer to pages i and ii at front of this catalog for features, available sizes, and ordering information.

EMAIL: hubsales@regalbelloit.com • www.regalbelloit.com

