

Hub City™ Worm Gear Drives

Double Reduction

PowerCubeX® Worm Speed Reducer Catalog Ratings

3000 Series • GW180 Primary • 300 Secondary

SERIES	INPUT RPM	UNIT RATIO	OUTPUT RPM	PRIM. RATIO	SEC. RATIO	ALL	CONVENTIONAL OIL		PAO SYNTHETIC OIL		PAG SYNTHETIC OIL	
						INPUT HP	EFF. %	OUTPUT TORQUE	EFF. %	OUTPUT TORQUE	EFF. %	OUTPUT TORQUE
3000	1750	50	35.0	5	10	2.42	68.4	2973	76.8	3340	81.7	3552
		75	23.3	5	15	1.90	65.3	3357	73.4	3772	78.0	4010
		100	17.5	5	20	1.66	62.3	3711	70.0	4170	74.4	4433
		150	11.7	10	15	1.08	61.4	3566	68.9	4007	73.3	4260
		200	8.75	10	20	0.94	58.0	3944	65.2	4431	69.3	4712
		250	7.00	10	25	0.81	55.3	4047	62.2	4547	66.1	4835
		300	5.83	20	15	0.61	55.5	3659	62.3	4111	66.3	4371
		400	4.38	20	20	0.54	52.1	4049	58.5	4549	62.2	4837
		500	3.50	25	20	0.45	50.2	4049	56.4	4549	60.0	4837
		600	2.92	20	30	0.43	46.8	4313	52.6	4846	55.9	5153
		750	2.33	25	30	0.35	45.0	4313	50.6	4846	53.7	5153
		900	1.94	30	30	0.32	41.8	4313	47.0	4846	50.0	5153
		1000	1.75	50	20	0.27	42.0	4049	47.2	4549	50.2	4837
		1200	1.46	40	30	0.25	39.5	4313	44.4	4846	47.2	5153
		1500	1.17	50	30	0.214	37.3	4313	42.0	4846	44.6	5153
		1800	0.97	60	30	0.192	34.6	4313	38.9	4846	41.3	5153
		2000	0.88	50	40	0.184	32.8	4334	36.8	4870	39.1	5178
2400	0.73	60	40	0.166	30.3	4334	34.0	4870	36.2	5178		
3000	0.58	60	50	0.139	27.6	4134	31.0	4645	33.0	4939		
3600	0.49	60	60	0.121	25.1	3924	28.2	4409	29.9	4688		

Worm Gear Drives



3200 Series • 210 Primary • 320 Secondary

SERIES	INPUT RPM	UNIT RATIO	OUTPUT RPM	PRIM. RATIO	SEC. RATIO	ALL	CONVENTIONAL OIL		PAO SYNTHETIC OIL		PAG SYNTHETIC OIL	
						INPUT HP	EFF. %	OUTPUT TORQUE	EFF. %	OUTPUT TORQUE	EFF. %	OUTPUT TORQUE
3200	1750	50	35.0	5	10	2.86	69.5	3582	78.1	4025	83.0	4279
		75	23.3	5	15	2.45	65.8	4343	73.9	4880	78.6	5188
		100	17.5	5	20	1.96	63.3	4472	71.2	5025	75.7	5342
		150	11.7	10	15	1.39	61.8	4654	69.4	5229	73.8	5560
		200	8.75	10	20	1.12	59.2	4766	66.5	5355	70.7	5694
		250	7.00	10	25	0.94	56.8	4833	63.9	5430	67.9	5774
		300	5.83	20	15	0.79	56.1	4794	63.0	5387	67.0	5727
		400	4.38	20	20	0.63	53.6	4898	60.2	5503	64.0	5851
		500	3.50	25	20	0.53	51.8	4898	58.2	5503	61.9	5851
		600	2.92	20	30	0.55	46.6	5560	52.4	6247	55.7	6642
		750	2.33	25	30	0.46	44.9	5560	50.5	6247	53.7	6642
		900	1.94	30	30	0.40	42.6	5560	47.9	6247	50.9	6642
		1000	1.75	50	20	0.31	43.9	4898	49.3	5503	52.4	5851
		1200	1.46	40	30	0.33	39.5	5560	44.4	6247	47.2	6642
		1500	1.17	50	30	0.27	37.6	5560	42.2	6247	44.9	6642
		1800	0.97	60	30	0.25	34.6	5560	38.9	6247	41.4	6642
		2000	0.88	50	40	0.211	34.5	5247	38.8	5896	41.2	6268
2400	0.73	60	40	0.193	31.4	5247	35.3	5896	37.5	6268		
3000	0.58	60	50	0.160	28.9	5008	32.5	5627	34.6	5983		
3600	0.49	60	60	0.134	26.9	4665	30.2	5242	32.1	5573		

ADDITIONAL RATINGS FOR OTHER INPUT SPEEDS ARE AVAILABLE AT: WWW.HUBCITYINC.COM

OVERHUNG LOAD AND THRUST LOAD INFORMATION

OVERHUNG LOAD - LOW SPEED SHAFT — MODELS 3001 AND 3004 1,150 LBS. AT CENTER POINT OF SHAFT EXTENSION. MODELS 3002 AND 3005 NOT APPLICABLE. THRUST± UP OR DOWN 1,725 LBS.

MODELS 3201 AND 3204 1,100 LBS. AT CENTER POINT OF SHAFT EXTENSION. MODELS 3202 AND 3205 NOT APPLICABLE.

MODELS 3207 AND 3208 — OHL* 1,280 LBS., TO* THRUST OUT 1,700 LBS. AND TI± THRUST IN 1,210 LBS. THRUST± UP OR DOWN 1,200 LBS.

±OHL AND THRUST VALUES SHOWN ARE INDEPENDENT FUNCTIONS AND CANNOT BE APPLIED SIMULTANEOUSLY. REFER APPLICATIONS WITH COMBINED OHL AND THRUST TO REGAL CUSTOMER SERVICE DEPARTMENT.

OUTPUT TORQUE VALUES SHOWN ARE INCH-POUNDS (IN-LB).

Hub City™ Worm Gear Drives

Double Reduction Models

1304, 1504, 1804, 2104, 2404, 2604, 3004, 3204, 3804, 4204, 4504, 5204, GW6004, GW7004, GW8004, GW10004

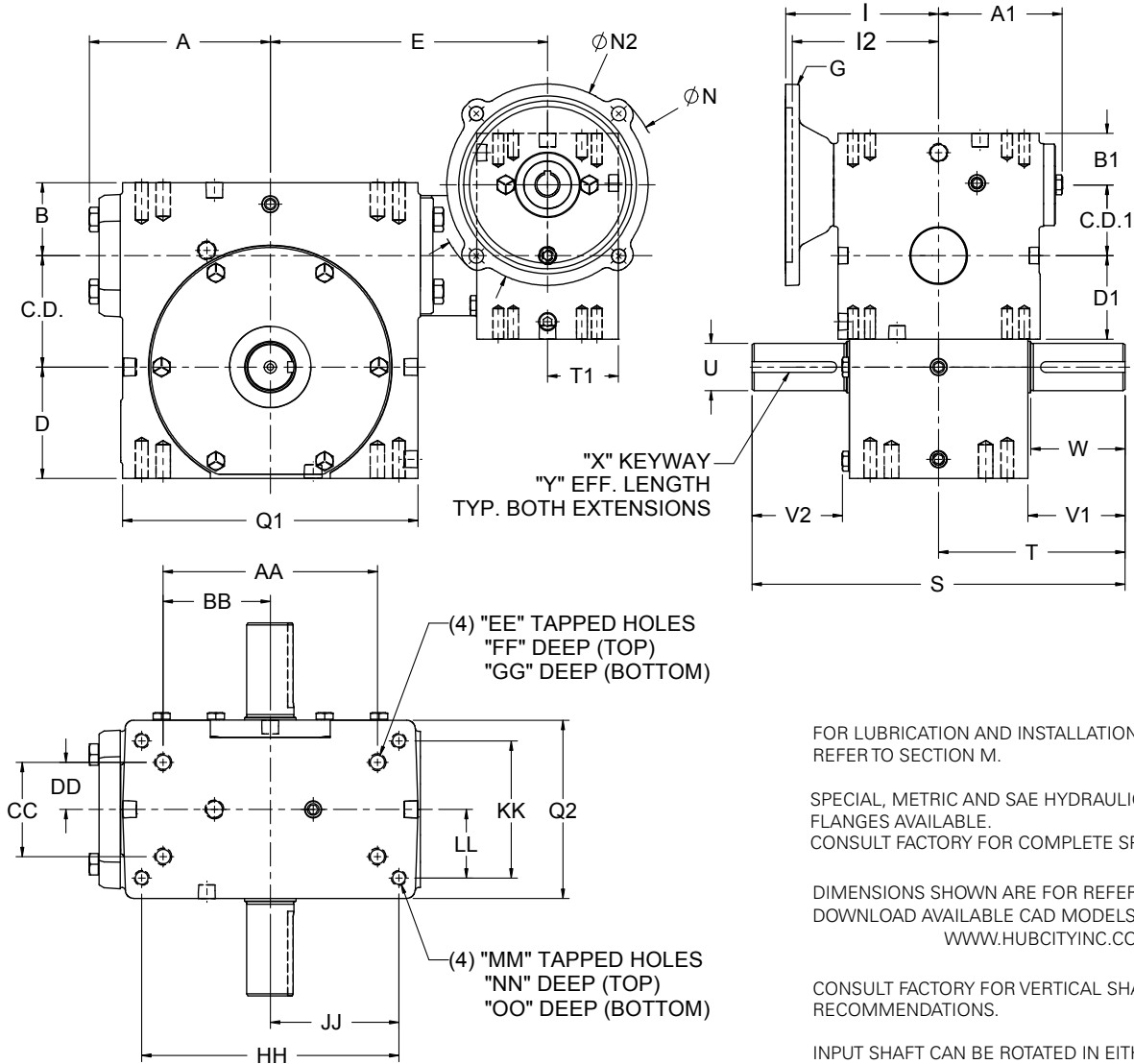

FOR LUBRICATION AND INSTALLATION INSTRUCTIONS REFER TO SECTION M.

SPECIAL, METRIC AND SAE HYDRAULIC INPUT FLANGES AVAILABLE. CONSULT FACTORY FOR COMPLETE SPECIFICATIONS.

DIMENSIONS SHOWN ARE FOR REFERENCE ONLY. DOWNLOAD AVAILABLE CAD MODELS AT: WWW.HUBCITYINC.COM

CONSULT FACTORY FOR VERTICAL SHAFT LUBRICATION RECOMMENDATIONS.

INPUT SHAFT CAN BE ROTATED IN EITHER DIRECTION.

Standard Styles Available

