

Hub City™ Worm Gear Drives

Single Reduction

PowerCubeX® Worm Speed Reducer Catalog Ratings

Series 180

SERIES	INPUT RPM	RATIO	OUTPUT RPM	CONVENTIONAL OIL					PAO SYNTHETIC OIL			PAG SYNTHETIC OIL		
				MECH. INPUT HP	EFF. %	MECH. OUTPUT TORQUE	THERMAL INPUT HP	THERMAL OUTPUT TORQUE	INPUT HP	EFF. %	OUTPUT TORQUE	INPUT HP	EFF. %	OUTPUT TORQUE
180	2500	5	500	3.00	86.8	328	2.11	231	3.00	92.0	348	3.00	94.8	358
		7.5	333	2.40	85.6	389	1.61	261	2.40	90.8	413	2.40	93.6	425
		10	250	1.96	84.7	418	1.42	304	1.96	89.8	443	1.96	92.6	457
		15	167	1.48	81.5	455	1.00	307	1.48	86.4	483	1.48	89.1	498
		20	125	1.16	79.8	465	1.04	416	1.16	84.6	493	1.16	87.2	509
		25	100	0.95	78.0	466	0.80	397	0.95	82.7	494	0.95	85.2	509
		30	83.3	0.84	74.0	471	0.68	383	0.84	78.4	499	0.84	80.8	515
		40	62.5	0.65	71.1	465	THERMAL EQUALS MECHANICAL	0.65	75.4	493	0.65	77.8	509	
		50	50.0	0.52	68.2	449		0.52	72.4	476	0.52	74.6	491	
		60	41.7	0.43	65.0	427		0.43	68.9	452	0.43	71.0	466	
	80	31.3	0.28	60.8	348	0.28		64.4	369	0.28	66.4	380		
		100	25.0	0.191	56.7	272	0.191	60.1	289	0.191	61.9	298		
	1750	5	350	2.57	85.9	397	2.04	315	2.57	91.1	421	2.57	93.9	434
		7.5	233	2.05	84.7	468	1.53	349	2.05	89.7	496	2.05	92.5	511
		10	175	1.63	83.6	491	1.34	404	1.63	88.6	520	1.63	91.4	536
		15	117	1.25	80.0	541	1.00	446	1.25	84.8	573	1.25	87.4	591
		20	87.5	1.00	78.0	541	0.90	510	1.00	82.7	574	1.00	85.3	591
		25	70.0	0.78	76.0	536	0.75	520	0.78	80.6	569	0.78	83.1	586
		30	58.3	0.75	71.5	557	0.64	495	0.75	75.8	590	0.75	78.1	609
		40	43.8	0.55	68.5	540	THERMAL EQUALS MECHANICAL	0.55	72.6	572	0.55	74.8	590	
		50	35.0	0.44	65.4	516		0.44	69.3	547	0.44	71.4	564	
		60	29.2	0.37	61.9	490		0.37	65.6	520	0.37	67.6	536	
	80	21.9	0.25	57.5	395	0.25		61.0	419	0.25	62.9	432		
		100	17.5	0.160	53.3	308	0.160	56.5	326	0.160	58.2	336		
	1170	5	234	2.02	84.9	461	1.84	419	2.02	90.0	489	2.02	92.8	504
		7.5	156	1.60	83.5	540	1.40	472	1.60	88.5	572	1.60	91.2	590
		10	117	1.25	82.3	555	THERMAL EQUALS MECHANICAL	1.25	87.2	589	1.25	89.9	607	
		15	78.0	1.00	78.1	617		1.00	82.8	654	1.00	85.3	675	
		20	58.5	0.75	76.0	608		0.75	80.6	644	0.75	83.1	664	
		25	46.8	0.60	73.8	598		0.60	78.2	634	0.60	80.6	654	
		30	39.0	0.57	68.7	634	0.57	72.8	672	0.57	75.0	693		
		40	29.3	0.43	65.5	606	0.43	69.4	642	0.43	71.5	662		
		50	23.4	0.34	62.2	575	0.34	65.9	610	0.34	68.0	629		
		60	19.5	0.29	58.5	546	0.29	62.0	579	0.29	63.9	597		
	80	14.6	0.187	54.0	436	0.187	57.3	462	0.187	59.0	476			
		100	11.7	0.126	49.7	338	0.126	52.7	358	0.126	54.3	369		
	100	5	20.0	0.244	79.1	607	THERMAL EQUALS MECHANICAL	0.244	83.8	644	0.244	86.4	664	
		7.5	13.3	0.194	76.6	702		0.194	81.2	744	0.194	83.8	767	
		10	10.0	0.147	75.2	697		0.147	79.7	739	0.147	82.2	762	
		15	6.7	0.122	68.3	788		0.122	72.4	836	0.122	74.7	861	
		20	5.0	0.091	65.8	754	0.091	69.8	799	0.091	71.9	824		
		25	4.0	0.074	63.0	731	0.074	66.8	775	0.074	68.8	799		
		30	3.3	0.077	55.3	806	0.077	58.7	854	0.077	60.5	881		
		40	2.5	0.057	52.0	748	0.057	55.2	793	0.057	56.9	818		
		50	2.0	0.046	48.5	702	0.046	51.4	744	0.046	53.0	767		
		60	1.7	0.040	44.4	666	0.040	47.1	706	0.040	48.5	728		
	80	1.3	0.026	40.2	521	0.026	42.7	553	0.026	44.0	570			
		100	1.0	0.018	36.1	402	0.018	38.3	426	0.018	39.5	439		

ADDITIONAL RATINGS FOR OTHER INPUT SPEEDS ARE AVAILABLE AT WWW.REGALBELOIT.COM

OVERHUNG LOAD AND THRUST LOAD INFORMATION

OVERHUNG LOAD - LOW SPEED SHAFT.

MODELS 181 AND 184 550 LBS. AT CENTER POINT OF SHAFT EXTENSION. MODELS 182 AND 185 NOT APPLICABLE.

THRUST± UP OR DOWN 600 LBS.

±OHL AND THRUST VALUES SHOWN ARE INDEPENDENT FUNCTIONS AND CANNOT BE APPLIED SIMULTANEOUSLY.

REFER APPLICATIONS WITH COMBINED OHL AND THRUST TO REGAL CUSTOMER SERVICE DEPARTMENT.

OUTPUT TORQUE VALUES SHOWN ARE INCH-POUNDS (IN-LB).

Hub City™ Worm Gear Drives

Single Reduction Models

135, 155, 185, 215, 245, 265, 305, 325, 385, 425, 455, 525, GW605

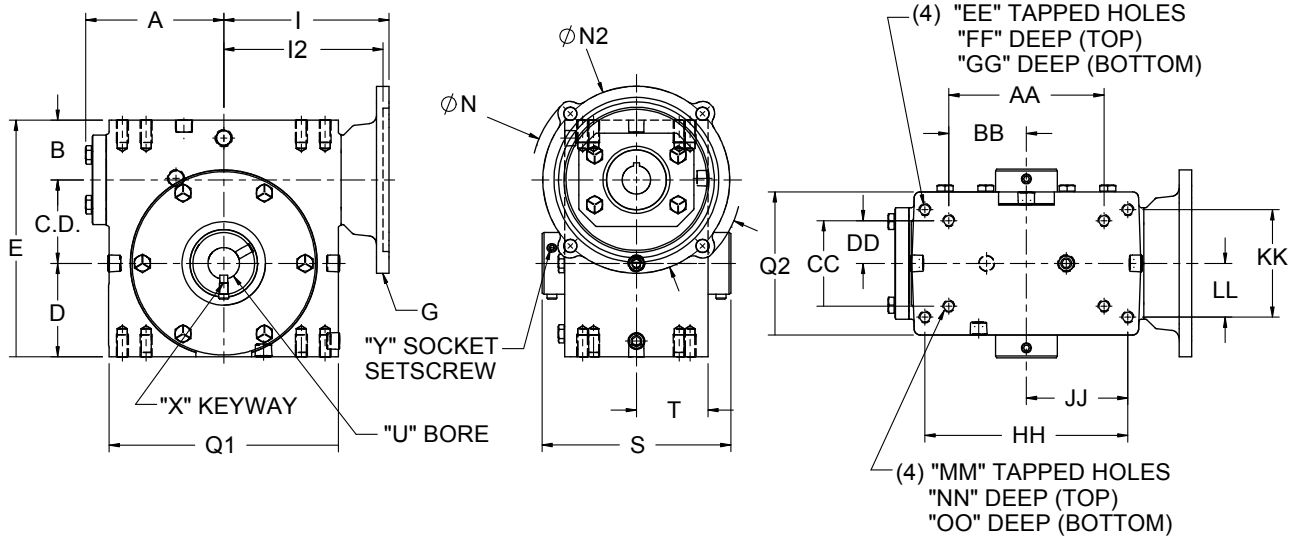

QD™ Bushing Detail for Models 455 & 525

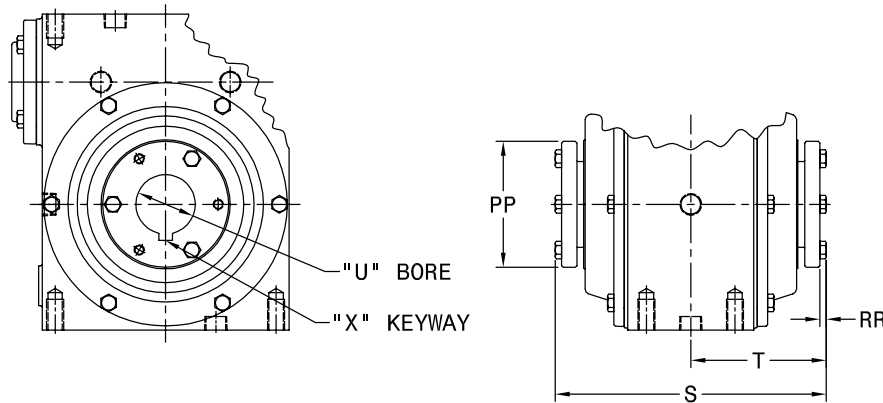

SPECIAL, METRIC AND SAE HYDRAULIC INPUT FLANGES AVAILABLE. CONSULT FACTORY FOR COMPLETE SPECIFICATIONS.

THESE UNITS CAN BE FURNISHED WITH SOLID OUTPUT SHAFT ON SPECIAL ORDERS.

SHAFT MOUNTED UNITS REQUIRE TORQUE ARMS. TORQUE ARM KITS ARE AVAILABLE. SEE PAGE B-105.

ALL GW MODELS ARE FAN COOLED REFER TO FAN DETAILS ON NEXT PAGE.

FOR LUBRICATION AND INSTALLATION INSTRUCTIONS - REFER TO SECTION M

DIMENSIONS SHOWN ARE FOR REFERENCE ONLY. DOWNLOAD AVAILABLE CAD MODELS AT: WWW.HUBCITYINC.COM

Standard Styles Available

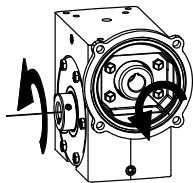

STYLE "A"

NOTE: STYLE "A" SUPPLIED AS STANDARD UNLESS SPECIFIED OTHERWISE.

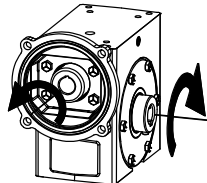

STYLE "B"

NOTE: STYLE B DOES NOT APPLY TO MODELS 455 AND LARGER. HOUSINGS HAVE A COVER ON BOTH SIDES OF OUTPUT.

CONSULT FACTORY FOR VERTICAL SHAFT LUBRICATION RECOMMENDATIONS.

INPUT SHAFT CAN BE ROTATED IN EITHER DIRECTION.



Select hollow output bore models in this product line are now available with the HubLoc® keyless bushing system. Refer to pages i and ii at front of this catalog for features, available sizes, and ordering information.

Hub City™ Worm Gear Drives

Single Reduction Models

135, 155, 185, 215, 245, 265, 305, 325, 385, 425, 455, 525, GW605

MODEL	C.D.	A	B	D	E	Q1	Q2
135	1.334	2.61	1.186	1.562	4.082	4.12	3.12
155	1.541	3.14	1.928	1.906	5.375	4.88	3.44
185	1.751	3.23	1.374	1.875	5.000	5.16	3.44
215	2.064	3.61	1.500	2.437	6.000	5.88	4.12
245	2.376	3.77	2.061	2.500	6.937	6.12	4.06
265	2.626	4.33	1.874	2.938	7.438	7.20	4.50
305	3.001	4.84	2.624	3.250	8.875	8.12	5.25
325	3.251	5.28	2.124	3.250	8.625	8.62	5.20
385	3.751	4.90	2.374	3.937	10.062	9.60	5.62
425	4.251	6.10	2.686	4.438	11.375	10.25	6.13
455	4.501	5.23	2.499	4.625	11.625	9.25	4.63
525	5.168	5.98	2.624	5.375	13.167	10.75	5.06
GW605	6.000	N/A	4.000	6.500	16.500	14.25	8.13

Stock Output Bores

MINIMUM AND MAXIMUM BORE DIMENSIONS SHOWN. FOR ADDITIONAL STOCK OUTPUT BORE SIZES AND STOCK QD™ BUSHING KITS AVAILABLE SEE PAGE B-96.

MODEL	U (MIN.)	U (MAX.)	S	T
135	N/A	5/8	4.50	2.25
155	N/A	5/8	5.42	2.71
185	15/16	1	4.81	2.41
215	15/16	1-1/2	5.56	2.78
245	1	1-1/2	6.00	3.00
265	1	1-1/2	5.93	2.97
305	1-3/16	2-3/16	7.50	3.75
325	1-7/16	2-3/16	7.56	3.78
385	1-7/16	2-3/16	7.56	3.78
425	1-7/16	2-3/16	8.50	4.25
455	QD BUSHING KIT REQUIRED		10.00	5.00
525	QD BUSHING KIT REQUIRED		11.13	5.56
GW605	2	3-7/16	11.50	5.75

Fan Detail for Model GW605

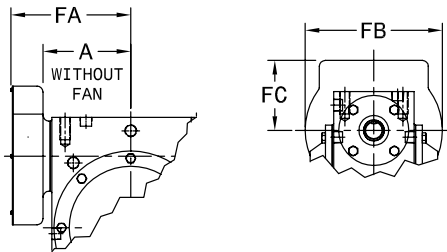

MODEL	A	FA	FB	FC
GW605	N/A	11.13	9.50	4.00

ALL GW MODELS ARE FAN COOLED.

MODEL	AA	BB	CC	DD	EE	FF	GG	HH	JJ	KK	LL	MM	NN	OO	Wt. Lbs.
135	2.250	1.125	1.625	0.813	1/4 UNC	0.50	0.50	3.250	1.625	2.000	1.000	5/16 UNC	0.50	0.50	16
155	4.188	2.094	2.750	1.375	5/16 UNC	0.63	0.63	N/A	N/A	N/A	N/A	N/A	N/A	N/A	16
185	3.125	1.563	1.625	0.813	1/4 UNC	0.50	0.50	4.188	2.094	2.750	1.375	5/16 UNC	0.63	0.63	16
215	4.000	2.000	2.000	1.000	3/8 UNC	0.50	0.70	5.000	2.500	2.875	1.438	3/8 UNC	0.70	0.70	25
245	5.000	2.500	2.875	1.438	3/8 UNC	0.69	0.69	N/A	N/A	N/A	N/A	N/A	N/A	N/A	38
265	4.875	2.438	2.688	1.344	3/8 UNC	0.70	0.70	6.375	3.188	3.375	1.688	3/8 UNC	0.70	0.70	38
305	7.000	3.500	4.000	2.000	7/16 UNC	0.88	0.88	N/A	N/A	N/A	N/A	N/A	N/A	N/A	61
325	6.250	3.125	2.750	1.375	1/2 UNC	0.75	0.75	7.500	3.750	4.000	2.000	7/16 UNC	0.88	0.88	70
385	6.875	3.438	3.000	1.500	1/2 UNC	0.94	1.00	8.500	4.250	4.750	2.375	1/2 UNC	1.00	1.00	86
425	8.500	4.250	5.000	2.500	5/8 UNC	1.00	1.00	N/A	N/A	N/A	N/A	N/A	N/A	N/A	117
455	8.125	4.063	3.250	1.625	5/8 UNC	0.88	1.13	N/A	N/A	N/A	N/A	N/A	N/A	N/A	117
525	9.500	4.750	3.750	1.875	5/8 UNC	1.00	1.25	N/A	N/A	N/A	N/A	N/A	N/A	N/A	145
GW605	12.750	6.375	6.380	3.190	5/8 UNC	1.00	1.00	N/A	N/A	N/A	N/A	N/A	N/A	N/A	330

MODEL	G	I	I2	N	N2
135	48CZ	3.46	N/A	4.36	3.87
	56C			6.63	6.50
155	48CZ	3.99	N/A	4.36	3.87
	56C			6.63	6.50
	143TC				
185	48CZ	4.09	N/A	4.36	3.87
	56C			6.63	6.50
	143TC				
215	48CZ	4.46	N/A	4.36	3.87
	56C			6.63	6.50
	143TC				
245	56C	4.63	N/A	6.50	6.50
	143TC			9.00	9.00
	182TC				
265	56C	5.19	N/A	6.50	6.50
	143TC			9.00	9.00
	182TC				
305	56C	5.95	N/A	6.50	6.50
	143TC			9.00	9.00
	182TC				
	213TC			N/A	6.71
325	56C	6.14	N/A	6.50	6.50
	143TC			9.00	9.00
	182TC				
213TC	N/A	6.90			
385	56C	6.50	N/A	6.50	6.50
	143TC			9.00	9.00
	182TC				
425	56C	6.45	N/A	6.50	6.50
	143TC			9.00	9.00
	182TC				
	213TC			N/A	7.77
254TC	N/A	7.77			
455	56C	6.75	N/A	6.50	6.50
	143TC			9.00	9.00
	182TC				
	213TC			N/A	6.75
525 *	182TC	N/A	7.50	9.00	9.00
	213TC				
GW605	56C	10.45	N/A	6.50	6.50
	143TC			9.00	9.00
	182TC				
	213TC			N/A	9.94
	254TC			N/A	9.94

* 56C & 143TC FLANGES AVAILABLE AS MODIFIED STANDARDS