

Hub City™ Worm Gear Drives

Single Reduction

PowerCubeX® Worm Speed Reducer Catalog Ratings

Series 260

SERIES	INPUT RPM	RATIO	OUTPUT RPM	CONVENTIONAL OIL					PAO SYNTHETIC OIL			PAG SYNTHETIC OIL		
				MECH. INPUT HP	EFF. %	MECH. OUTPUT TORQUE	THERMAL INPUT HP	THERMAL OUTPUT TORQUE	INPUT HP	EFF. %	OUTPUT TORQUE	INPUT HP	EFF. %	OUTPUT TORQUE
260	2500	5	500	8.61	87.4	948	4.30	473	8.61	92.6	1005	8.61	95.5	1037
		7.5	333	6.68	86.6	1095	3.70	607	6.68	91.8	1160	6.68	94.7	1196
		10	250	5.64	85.8	1220	3.65	790	5.64	91.0	1293	5.64	93.8	1333
		15	167	4.03	84.4	1288	2.30	735	4.03	89.5	1365	4.03	92.2	1407
		20	125	3.21	82.1	1329	2.47	1023	3.21	87.0	1409	3.21	89.7	1453
		25	100	2.65	80.5	1345	2.25	1142	2.65	85.3	1426	2.65	88.0	1470
		30	83.3	2.26	79.0	1350	1.36	812	2.26	83.7	1431	2.26	86.3	1476
		40	62.5	1.77	74.8	1336	1.38	1042	1.77	79.3	1417	1.77	81.8	1460
		50	50.0	1.43	72.2	1302	1.35	1229	1.43	76.5	1380	1.43	78.9	1422
		60	41.7	1.17	69.7	1236	0.89	940	1.17	73.9	1311	1.17	76.2	1351
	80	31.3	0.77	65.8	1021	0.67	888	0.77	69.8	1082	0.77	72.0	1116	
	100	25.0	0.51	62.1	801	0.45	707	0.51	65.9	849	0.51	67.9	876	
	1750	5	350	7.35	86.7	1147	4.21	657	7.35	91.9	1216	7.35	94.7	1254
		7.5	233	5.73	85.8	1327	3.62	838	5.73	90.9	1407	5.73	93.7	1450
		10	175	5.00	84.8	1485	3.55	1054	5.00	89.9	1575	5.00	92.7	1623
		15	117	3.49	83.2	1570	2.20	990	3.49	88.2	1664	3.49	90.9	1716
		20	87.5	2.83	80.6	1640	2.37	1373	2.83	85.4	1738	2.83	88.0	1792
		25	70.0	2.31	78.7	1640	2.12	1505	2.31	83.5	1739	2.31	86.1	1793
		30	58.3	2.00	77.0	1634	1.29	1054	2.00	81.7	1732	2.00	84.2	1785
		40	43.8	1.58	72.4	1642	1.31	1361	1.58	76.7	1741	1.58	79.1	1795
		50	35.0	1.27	69.5	1583	1.27	1583	1.27	73.6	1678	1.27	75.9	1730
		60	29.2	1.03	66.8	1493	0.84	1218	1.03	70.8	1583	1.03	73.0	1632
	80	21.9	0.67	62.7	1212	0.59	1067	0.67	66.4	1285	0.67	68.5	1325	
	100	17.5	0.45	58.7	945	0.40	840	0.45	62.3	1001	0.45	64.2	1032	
	1170	5	234	6.19	85.7	1429	3.81	880	6.19	90.9	1515	6.19	93.7	1562
		7.5	156	4.81	84.7	1644	3.25	1111	4.81	89.8	1743	4.81	92.5	1796
		10	117	3.98	83.6	1792	3.20	1441	3.98	88.6	1899	3.98	91.3	1958
		15	78.0	2.77	81.7	1830	2.12	1401	2.77	86.6	1940	2.77	89.3	2000
		20	58.5	2.28	78.7	1929	2.26	1912	2.28	83.4	2045	2.28	86.0	2108
		25	46.8	1.85	76.6	1912	1.85	1912	1.85	81.3	2027	1.85	83.8	2090
		30	39.0	1.57	74.7	1893	1.27	1531	1.57	79.2	2007	1.57	81.7	2069
		40	29.3	1.29	69.5	1926			1.29	73.7	2042	1.29	76.0	2105
		50	23.4	1.03	66.3	1842			1.03	70.3	1952	1.03	72.5	2013
		60	19.5	0.84	63.5	1728			0.84	67.3	1832	0.84	69.4	1888
	100	80	14.6	0.54	59.1	1384			0.54	62.7	1468	0.54	64.6	1513
		100	11.7	0.36	55.0	1073			0.36	58.3	1138	0.36	60.1	1173
		5	20.0	0.86	79.4	2144			0.86	84.2	2273	0.86	86.8	2344
		7.5	13.3	0.67	77.6	2439			0.67	82.2	2586	0.67	84.8	2666
		10	10.0	0.53	76.0	2531			0.53	80.5	2683	0.53	83.0	2766
		15	6.7	0.35	73.5	2429			0.35	77.9	2575	0.35	80.3	2654
20		5.0	0.30	68.3	2604			0.30	72.5	2760	0.30	74.7	2846	
25		4.0	0.246	65.5	2538			0.246	69.4	2691	0.246	71.6	2774	
30		3.3	0.209	62.9	2485			0.209	66.7	2634	0.209	68.7	2716	
40		2.5	0.185	55.3	2585			0.185	58.6	2741	0.185	60.4	2826	
50	2.0	0.150	51.6	2435			0.150	54.7	2581	0.150	56.4	2661		
60	1.7	0.124	48.3	2261			0.124	51.2	2397	0.124	52.8	2471		
80	1.3	0.080	44.0	1769			0.080	46.6	1875	0.080	48.0	1933		
100	1.0	0.054	39.9	1357			0.054	42.2	1439	0.054	43.6	1484		

Worm Gear Drives



ADDITIONAL RATINGS FOR OTHER INPUT SPEEDS ARE AVAILABLE AT WWW.REGALBELOIT.COM

OVERHUNG LOAD AND THRUST LOAD INFORMATION

OVERHUNG LOAD - LOW SPEED SHAFT — MODELS 261 AND 264 1150 LBS. AT CENTER POINT OF SHAFT EXTENSION. MODELS 262 AND 265 NOT APPLICABLE. THRUST± UP OR DOWN 1000 LBS.

±OHL AND THRUST VALUES SHOWN ARE INDEPENDENT FUNCTIONS AND CANNOT BE APPLIED SIMULTANEOUSLY. REFER APPLICATIONS WITH COMBINED OHL AND THRUST TO REGAL CUSTOMER SERVICE DEPARTMENT.

OUTPUT TORQUE VALUES SHOWN ARE INCH-POUNDS (IN-LB).

Hub City™ Worm Gear Drives

Single Reduction Models

132, 152, 182, 212, 242, 262, 302, 322, 382, 422, 452, 522, GW602, GW702, GW802, GW1002

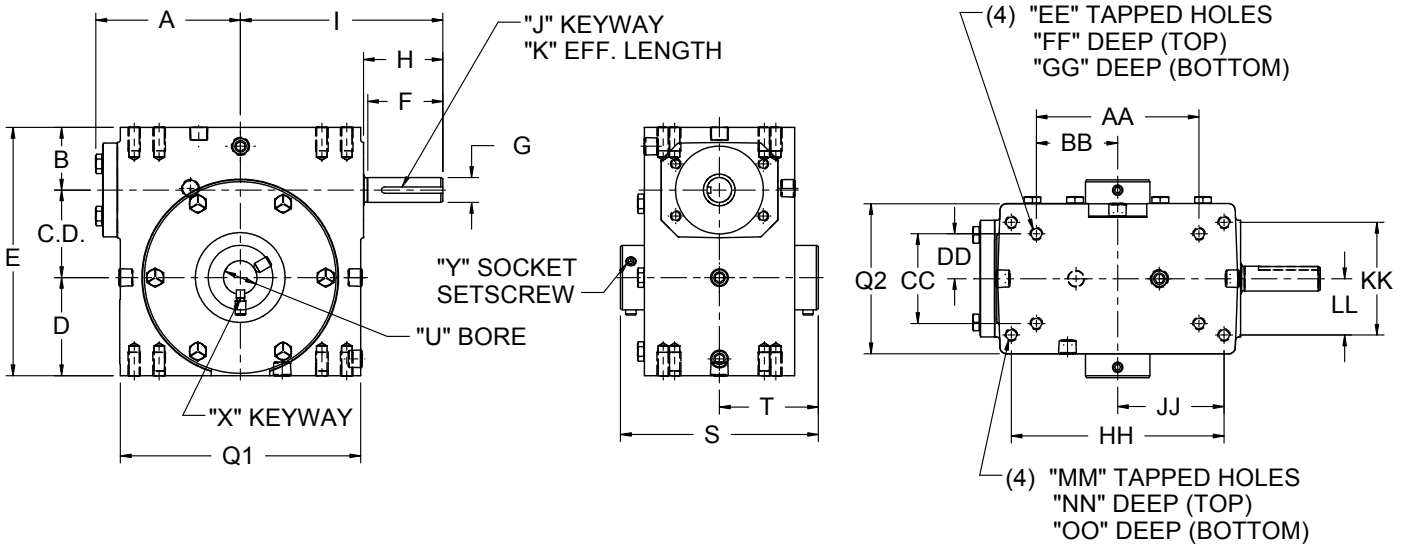

QD™ Bushing Detail for Models 452, 522

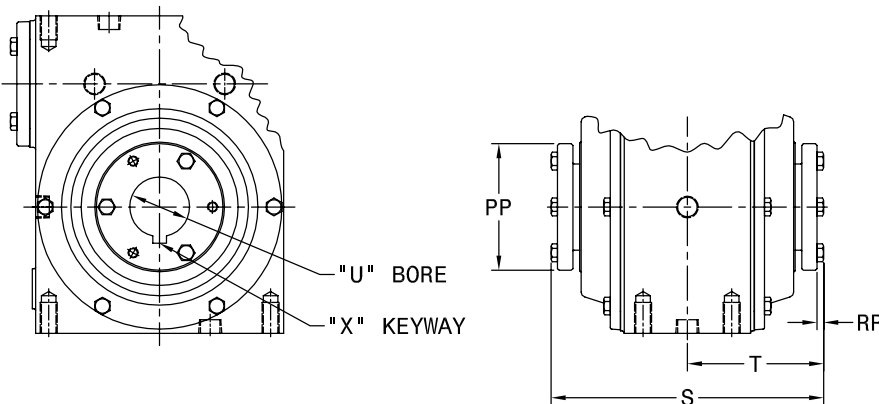

THESE UNITS CAN BE FURNISHED WITH SOLID OUTPUT SHAFT ON SPECIAL ORDERS.

SHAFT MOUNTED UNITS REQUIRE TORQUE ARMS. TORQUE ARM KITS ARE AVAILABLE. SEE PAGE B-105.

ALL GW MODELS ARE FAN COOLED REFER TO FAN DETAILS ON NEXT PAGE.

FOR LUBRICATION AND INSTALLATION INSTRUCTIONS - REFER TO SECTION M

DIMENSIONS SHOWN ARE FOR REFERENCE ONLY. DOWNLOAD AVAILABLE CAD MODELS AT: WWW.HUBCITYINC.COM

Standard Styles Available

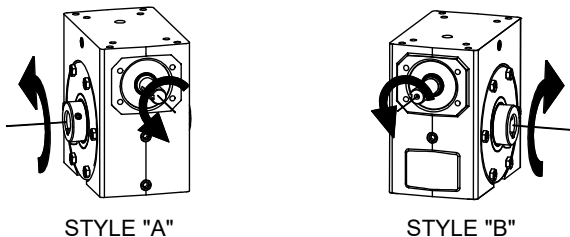

STYLE "A"

STYLE "B"

CONSULT FACTORY FOR VERTICAL SHAFT LUBRICATION RECOMMENDATIONS.

INPUT SHAFT CAN BE ROTATED IN EITHER DIRECTION.

NOTE: STYLE "A" SUPPLIED AS STANDARD UNLESS SPECIFIED OTHERWISE.

NOTE: STYLE B DOES NOT APPLY TO MODELS 452 AND LARGER. HOUSINGS HAVE A COVER ON BOTH SIDES OF OUTPUT.

Hub City™ Worm Gear Drives

Single Reduction Models

132, 152, 182, 212, 242, 262, 302, 322, 382, 422, 452, 522, GW602, GW702, GW802, GW1002

MODEL	C.D.	A	B	D	E	Q1	Q2	F	G	H	I	J	K
132	1.334	2.61	1.186	1.562	4.082	4.12	3.12	1.67	.500/.4985	1.76	3.82	1/8 X 1/16 P&W	1.44
152	1.541	3.14	1.928	1.906	5.375	4.88	3.44	1.76	.625/.6235	1.76	4.35	3/16 X 3/32 P&W	1.50
182	1.751	3.23	1.374	1.875	5.000	5.16	3.44	N/A	.625/.6235	1.76	4.44	3/16 X 3/32 P&W	1.50
212	2.064	3.61	1.500	2.437	6.000	5.88	4.12	N/A	.625/.6235	1.76	4.82	3/16 X 3/32 P&W	1.50
242	2.376	3.77	2.061	2.500	6.937	6.12	4.06	2.38	.750/.7485	2.38	5.51	3/16 X 3/32 P&W	1.75
262	2.626	4.33	1.874	2.938	7.438	7.20	4.50	2.36	.750/.7485	2.38	6.07	3/16 X 3/32 P&W	1.75
302	3.001	4.84	2.624	3.250	8.875	8.12	5.25	2.38	.875/.8735	2.38	6.57	3/16 X 3/32 P&W	1.75
322	3.251	5.28	2.124	3.250	8.625	8.62	5.20	N/A	.875/.8735	2.38	6.75	3/16 X 3/32 P&W	1.75
382	3.751	4.90	2.374	3.937	10.062	9.60	5.62	2.20	1.000/.999	2.48	7.38	1/4 X 1/8 P&W	1.91
422	4.251	6.10	2.686	4.438	11.375	10.25	6.13	3.47	1.250/1.2485	3.47	9.60	1/4 X 1/8 P&W	2.87
452	4.501	5.23	2.499	4.625	11.625	9.25	4.63	2.98	1.125/1.124	3.21	8.44	1/4 X 1/8	2.50
522	5.168	5.98	2.624	5.375	13.167	10.75	5.06	N/A	1.250/1.249	3.27	9.25	1/4 X 1/8	2.63
GW602	6.000	N/A	4.000	6.500	16.500	14.25	8.13	N/A	1.500	3.41	11.78	3/8 X 3/16	3.00
GW702	7.000	N/A	4.320	7.590	18.910	14.88	7.63	N/A	1.625	2.98	11.50	3/8 X 3/16 P&W	2.87
GW802	8.000	N/A	4.100	8.860	20.960	17.00	8.63	N/A	1.875	2.84	12.50	1/2 X 1/4 P&W	2.81
GW1002	10.000	N/A	5.110	10.360	25.470	20.88	9.53	N/A	2.250	3.76	15.50	1/2 X 1/4 P&W	3.69

MODEL	AA	BB	CC	DD	EE	FF	GG	HH	JJ	KK	LL	MM	NN	OO	Wt. Lbs.
132	2.250	1.125	1.625	0.813	1/4 UNC	0.50	0.50	3.250	1.625	2.000	1.000	5/16 UNC	0.50	0.50	15
152	4.188	2.094	2.750	1.375	5/16 UNC	0.63	0.63	N/A	N/A	N/A	N/A	N/A	N/A	N/A	15
182	3.125	1.563	1.625	0.813	1/4 UNC	0.50	0.50	4.188	2.094	2.750	1.375	5/16 UNC	0.63	0.63	15
212	4.000	2.000	2.000	1.000	3/8 UNC	0.50	0.70	5.000	2.500	2.875	1.438	3/8 UNC	0.70	0.70	24
242	5.000	2.500	2.875	1.438	3/8 UNC	0.69	0.69	N/A	N/A	N/A	N/A	N/A	N/A	N/A	37
262	4.875	2.438	2.688	1.344	3/8 UNC	0.70	0.70	6.375	3.188	3.375	1.688	3/8 UNC	0.70	0.70	37
302	7.000	3.500	4.000	2.000	7/16 UNC	0.88	0.88	N/A	N/A	N/A	N/A	N/A	N/A	N/A	57
322	6.250	3.125	2.750	1.375	1/2 UNC	0.75	0.75	7.500	3.750	4.000	2.000	7/16 UNC	0.88	0.88	66
382	6.875	3.438	3.000	1.500	1/2 UNC	0.94	1.00	8.500	4.250	4.750	2.375	1/2 UNC	1.00	1.00	85
422	8.500	4.250	5.000	2.500	5/8 UNC	1.00	1.00	N/A	N/A	N/A	N/A	N/A	N/A	N/A	107
452	8.125	4.063	3.250	1.625	5/8 UNC	0.88	1.13	N/A	N/A	N/A	N/A	N/A	N/A	N/A	107
522	9.500	4.750	3.750	1.875	5/8 UNC	1.00	1.25	N/A	N/A	N/A	N/A	N/A	N/A	N/A	135
GW602	12.750	6.375	6.380	3.190	5/8 UNC	1.00	1.00	N/A	N/A	N/A	N/A	N/A	N/A	N/A	294
GW702	12.500	6.250	5.500	2.750	1 UNC	1.56	1.56	N/A	N/A	N/A	N/A	N/A	N/A	N/A	399
GW802	14.250	7.125	6.500	3.250	1 UNC	1.66	1.66	N/A	N/A	N/A	N/A	N/A	N/A	N/A	582
GW1002	17.750	8.875	6.875	3.438	1-1/4 UNC	2.04	2.04	N/A	N/A	N/A	N/A	N/A	N/A	N/A	905

Stock Output Bores

MINIMUM AND MAXIMUM BORE DIMENSIONS SHOWN. FOR ADDITIONAL STOCK OUTPUT BORE SIZES AND STOCK QD™ BUSHING KITS AVAILABLE SEE PAGE B-96.

MODEL	U (MIN.)	U (MAX.)	S	T
132	N/A	5/8	4.50	2.25
152	N/A	5/8	5.42	2.71
182	15/16	1	4.81	2.41
212	15/16	1-1/2	5.56	2.78
242	1	1-1/2	6.00	3.00
262	1	1-1/2	5.93	2.97
302	1-3/16	2-3/16	7.50	3.75
322	1-7/16	2-3/16	7.56	3.78
382	1-7/16	2-3/16	7.56	3.78
422	1-7/16	2-3/16	8.50	4.25
452	*QD BUSHING KIT REQUIRED*		10.00	5.00
522			11.13	5.56
GW602	2	3-7/16	11.50	5.75
GW702	2-7/16	3-15/16	13.50	6.75
GW802	3-7/16	4-7/16	14.50	7.25
GW1002	3-7/16	5-7/16	18.50	9.25

Fan Detail For Models GW602 Through GW1002

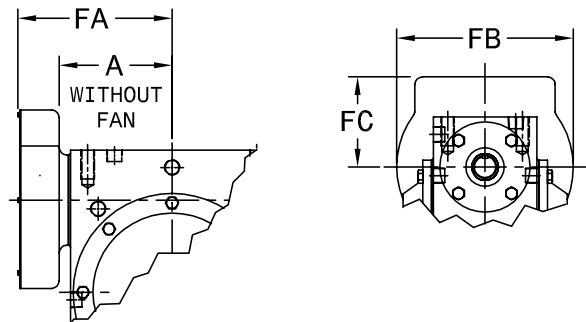

MODEL	A	FA	FB	FC
GW602	N/A	11.13	9.50	4.00
GW702	N/A	11.37	9.65	4.83
GW802	N/A	12.52	9.65	4.83
GW1002	N/A	14.69	11.28	5.62

ALL GW MODELS ARE FAN COOLED.



Select hollow output bore models in this product line are now available with the HubLoc® keyless bushing system. Refer to pages i and ii at front of this catalog for features, available sizes, and ordering information.