

SMA

Adaptor
SMA Jack – SMA Jack

32K601-K00L5

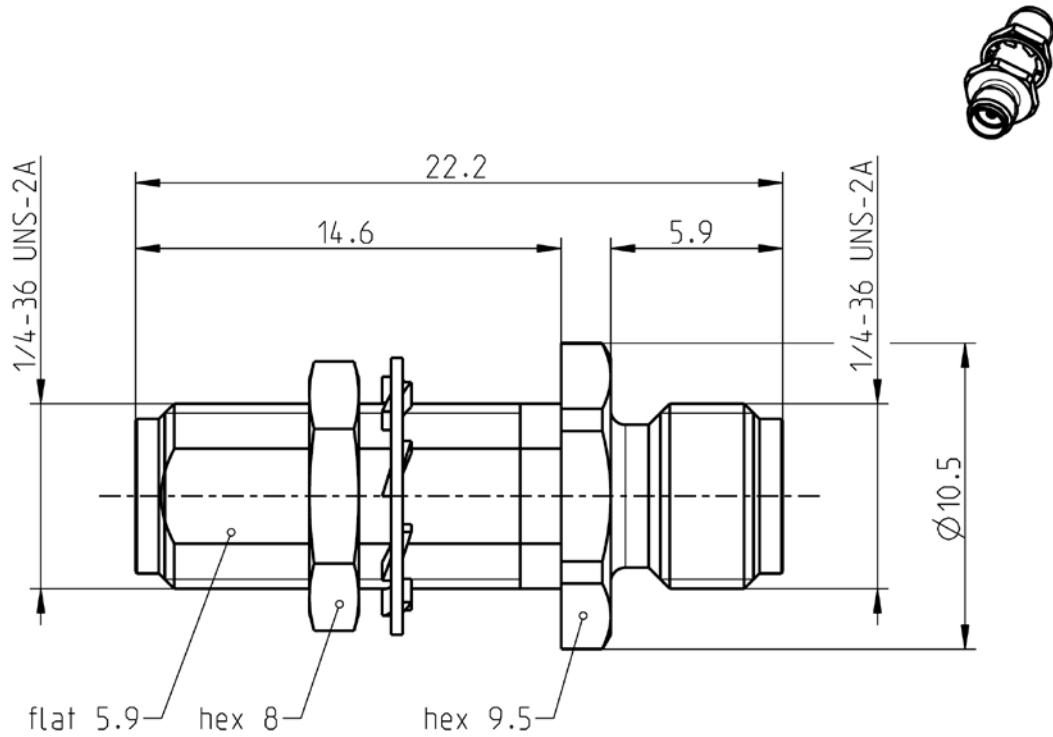

All dimensions are in mm; tolerances according to ISO 2768 m-H

Interface

According to IEC 60169-15, EN 122110, MIL-STD-348A, Fig. 310

Documents

Panel piercing B 56

Material and Plating

Connector parts

Center contact
Outer contact
Dielectric

Material

CuBe
CuBe or equiv.
PTFE

Plating

AuroDur®, gold plated
AuroDur®, gold plated

Dieses Dokument ist urheberrechtlich geschützt • This document is protected by copyright • Rosenberger Hochfrequenztechnik GmbH & Co. KG

RF_35/05.10/6.0

Technical Data Sheet

Rosenberger

SMA

Adaptor
SMA Jack – SMA Jack

32K601-K00L5

Electrical Data

Impedance	50 Ω
Frequency	DC to 18 GHz
Return loss	≤ 1.05 + 0.005 x f [GHz]
Insertion loss	≤ 0.03 x √f(GHz) dB
Insulation resistance	≥ 5 x10 ³ MΩ
Center contact resistance	≤ 3 mΩ
Outer contact resistance	≤ 2 mΩ
Test voltage	1000 V rms
Working voltage	480 V rms
Power handling (at 20 °C, sea level, VSWR 1.0)	≤ 200 W @ 2 GHz
RF-leakage	≥ 100 dB up to 1 GHz

Mechanical Data

Mating cycles	≥ 500
Center contact captivation: axial	≥ 27 N
radial	≥ 3 Ncm
Coupling test torque	≤ 1.7 Nm
Recommended torque	0.8 Nm to 1.1 Nm

- Panel thickness max. 6.4 mm -

Environmental Data

Temperature range	-65 °C to +165 °C
Thermal shock	MIL-STD-202, Method 107, Condition B
Corrosion	MIL-STD-202, Method 101, Condition B
Vibration	MIL-STD-202, Method 204, Condition D
Shock	MIL-STD-202, Method 213, Condition I
Moisture resistance	MIL-STD-202, Method 106
RoHS	compliant

Tooling

N/A

Suitable Cables

N/A

Weight

Weight 3.4 g/pc

While the information has been carefully compiled to the best of our knowledge, nothing is intended as representation or warranty on our part and no statement herein shall be construed as recommendation to infringe existing patents. In the effort to improve our products, we reserve the right to make changes judged to be necessary.

Draft	Date	Approved	Date	Rev.	Engineering change number	Name	Date
F. Fraunhofer	27.03.14	E_Schwangler	03.12.14	b00	14-1784	A_Wallner	03.12.14
Rosenberger Hochfrequenztechnik GmbH & Co. KG P.O.Box 1260 D-84526 Tittmoning Germany www.rosenberger.de				Tel. : +49 8684 18-0 Email : info@rosenberger.de			Page 2 / 2