

# Environment-resistive Remote Terminal NXR-series IO-Link Master Unit for EtherNet/IP™

# NXR-ILM08C-EIT

CSM\_NXR-ILM08C-EIT\_DS\_E\_2\_1

**Streamline commissioning and maintenance of production equipment.  
Simple, easy, and quick - Reduce Availability Loss and Quality Loss!**



## Features

- IP67 protection
- Replacement without software
- Ethernet cable diagnostics
  - Reports approximate locations of disconnections or short circuits in Ethernet cables
- Communication quality of EtherNet/IP
  - Records the total number of received FCS errors which allows checking communication quality
- Communication quality of IO-Link
  - Records the total number of lost frames which allows checking communication quality
- Location of short circuits
  - Detects and protects from short circuits in connection to IO-Link devices or standard devices
- Power supply voltage monitoring
  - Monitors power supply voltage for the unit and inputs and power supply voltage for outputs
- Power OUT connector for through-wiring for power supply
- Built-in L2 switching hub for through-wiring for Ethernet

System Configuration

System Configuration

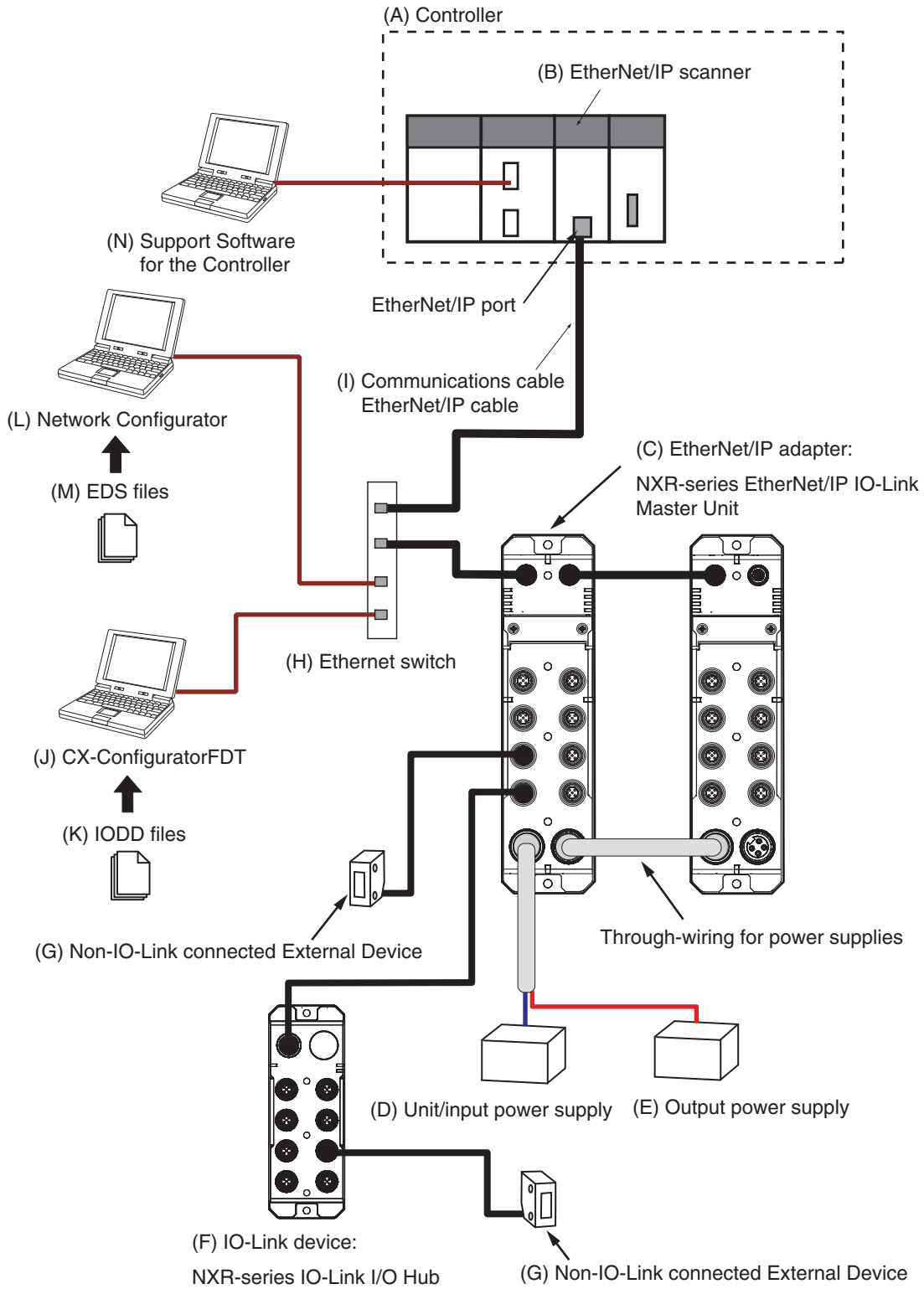

The components are described in the table below.

Letter	Name	Function
(A)	Controller	This is an OMRON CPU Unit or a controller from another company, connected to the IO-Link Master Unit through an EtherNet/IP adapter.
(B)	EtherNet/IP scanner	The EtherNet/IP scanner monitors the status of the connections with EtherNet/IP adapters and exchanges I/O data with EtherNet/IP adapters through the EtherNet/IP network. It refers to the <i>originator</i> when opening a connection.
(C)	EtherNet/IP adapter: NXR-series IO-Link Master Unit for EtherNet/IP	The NXR-series IO-Link Master Unit for EtherNet/IP is an EtherNet/IP adapter that provides IO-Link master functions. You can connect IO-Link devices and non-IO-Link connected external devices to the NXR-series IO-Link Master Unit for EtherNet/IP. It exchanges data with IO-Link devices through IO-Link communications.
(D)	Unit/input power supply	The Unit/input power supply provides power to the IO-Link Master Unit for operation and interface with input devices. Connect an external power supply to the power supply connector (input).
(E)	Output power supply	The output power supply provides power for interface with output devices. Connect an external power supply to the power supply connector (input).
(F)	IO-Link device: NXR-series IO-Link I/O Hub	The IO-Link device is a sensor, actuator, or other device that performs IO-Link communications with the IO-Link master. It exchanges data with the NXR-series IO-Link Master Unit for EtherNet/IP in IO-Link communications. You can connect non-IO-Link connected external devices to the NXR-series IO-Link I/O Hub.
(G)	Non-IO-Link connected External Device	The non-IO-Link connected external device is a sensor, actuator, or other device that handles ON/OFF signals that are not supported by IO-Link.
(H)	Ethernet switch	This is a relay device that connects multiple nodes.
(I)	Communications cable EtherNet/IP cable	Use a double-shielded cable with aluminum tape and braiding of category 5 (100BASE-TX) or higher, and use straight wiring.
(J)	CX-ConfiguratorFDT	The CX-ConfiguratorFDT is the Support Software to configure and monitor IO-Link devices that are connected to the IO-Link Master Unit.
(K)	IODD files	These files contain IO-Link device definitions.
(L)	Network Configurator	The Network Configurator is the Support Software to configure an EtherNet/IP network. For the IO-Link Master Unit, it is used for the following purposes. <ul style="list-style-type: none"> <li>Setting the device parameters of the IO-Link Master Unit</li> <li>Setting the connection between the EtherNet/IP scanner and the IO-Link Master Unit</li> </ul>
(M)	EDS files	The EDS files contain information that is unique to the IO-Link Master Unit. You can load EDS files into the Network Configurator or other Support Software for EtherNet/IP network setup to easily allocate data and view or change settings.
(N)	Support Software for the Controller	The Support Software is used to configure the Controller and EtherNet/IP scanner, create user programs, and perform monitoring, and troubleshooting. The Support Software depends on the Controller that you use.

## Applicable Support Software

The following table shows support software that can be used in the system configured with the NXR-series EtherNet/IP IO-Link Master Unit. For versions of support software, refer to Version Information on page 11.

IO-Link Master Unit connected to		Purposes and support software			
Controller	EtherNet/IP Scanner	Creating user programs	Setting connections	Setting device parameters of IO-Link Master Unit	Setting and monitoring connected IO-Link devices
NJ/NX-series CPU Unit	Built-in EtherNet/IP port on an NJ/NX-series CPU Unit or CJ1W-EIP21	Sysmac Studio	Sysmac Studio or Network Configurator	Network Configurator	CX-ConfiguratorFDT
CJ/CP/CS-series CPU Unit	<ul style="list-style-type: none"> <li>EtherNet/IP unit CJ1W-EIP21 or CS1W-EIP21</li> <li>CJ-series CPU unit Built-in EtherNet/IP port</li> </ul>	CX-Programmer	Network Configurator		
Controller from another manufacturer	EtherNet/IP Scanner from another manufacturer	Software from another manufacturer	Software from another manufacturer		

# NXR-ILM08C-EIT

## Ordering Information

### Applicable standards

Refer to the OMRON website (www.ia.omron.com) or ask your OMRON representative for the most recent applicable standards for each model.

### NXR-series IO-Link Master Unit for EtherNet/IP™

Product name	Number of IO-Link ports	Degree of protection	I/O connection terminals	Model
IO-Link Master Unit for EtherNet/IP	8	IP67	M12 connector A-cording, female	NXR-ILM08C-EIT

### NXR-series IO-Link I/O Hub

Product name	Number of IO-Link ports	Input/Output	Degree of protection	I/O connection terminals	Model
IO-Link I/O Hub	8	16 digital inputs	IP67	M12 connector A-cording, female	NXR-ID166C-IL2
		16 digital inputs/outputs			NXR-CD166C-IL2

### Software

#### How to Select Required Support Software for Your Controller

The required Support Software depends on the Controller to connect. Please check the following table when purchasing the Support Software.

Item	Omron PLC System	Omron Machine Automation Controller System
Controller	CJ-series	NJ/NX-series
Software	FA Integrated Tool Package CX-One	Automation Software Sysmac Studio

#### FA Integrated Tool Package CX-One

Product name	Specifications	Specifications		Model
		Number of licenses	Media	
FA Integrated Tool Package CX-One Ver.4.□	<p>The CX-One is a comprehensive software package that integrates Support Software for OMRON PLCs and components.</p> <p>CX-One runs on the following OS.                      Windows XP (Service Pack 3 or higher, 32-bit version) /                      Windows Vista (32-bit/64-bit version) / Windows 7 (32-bit/64-bit version) /                      Windows 8 (32-bit/64-bit version) / Windows 8.1 (32-bit/64-bit version) /                      Windows 10 (32-bit/64-bit version)</p> <p>CX-One Version 4.□ includes CX-Programmer Ver.9.□                      For details, refer to the <i>CX-One catalog</i> (Cat. No. R134)</p>	1 license *1	DVD	CXONE-AL01D-V4

\*1 Multi licenses (3, 10, 30, or 50 licenses) and DVD media without licenses are also available for the CX-One.

#### Automation Software Sysmac Studio

Please purchase a DVD and required number of licenses the first time you purchase the Sysmac Studio. DVDs and licenses are available individually. Each model of licenses does not include any DVD.

Product name	Specifications	Specifications		Model
		Number of licenses	Media	
Sysmac Studio Standard Edition Ver.1.□□	<p>The Sysmac Studio is the software that provides an integrated environment for setting, programming, debugging and maintenance of machine automation controllers including NJ/NX-series CPU Units, NY-series Industrial PC, EtherCAT Slaves, and HMI.</p> <p>Sysmac Studio runs on the following OS.                      Windows 7 (32-bit/64-bit version) / Windows 8 (32-bit/64-bit version) /                      Windows 8.1 (32-bit/64-bit version) /                      Windows 10 (32-bit/64-bit version) *1</p> <p>The Sysmac Studio Standard Edition DVD includes Support Software to set up EtherNet/IP Units, DeviceNet slaves, Serial Communications Units, and Support Software for creating screens on HMIs (CX-Designer).                      For details, refer to your OMRON website.</p>	-	Sysmac Studio (32 bit) DVD	SYSMAC-SE200D
			(Media only)	Sysmac Studio (64 bit) DVD
		1 license *2	-	SYSMAC-SE201L

\*1. SYSMAC-SE200D-64 runs on Windows 10 (64 bit).

\*2. Multi licenses are available for the Sysmac Studio (3, 10, 30, or 50 licenses).

## EtherNet/IP Communications Cables

Ethernet communications cables to connect the IO-Link master unit.

### Connection Cables between IO-Link Master Unit and EtherNet/IP Scanner with RJ45 Connectors

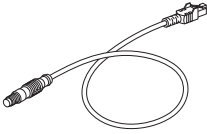

Name and appearance	Manufacturer	Specification	No. of cable conductors	Connector	Cable connection direction	Cable length	Model
Industrial Ethernet Connectors with Cable 	HARTING K.K.	M12 plug (D-coding, male) to RJ45	4	Screw connector	Straight/straight	0.5 m	72MDm4Rm4005K
						1 m	72MDm4Rm4010K
						2 m	72MDm4Rm4020K
						3 m	72MDm4Rm4030K
						5 m	72MDm4Rm4050K
						10 m	72MDm4Rm4100K

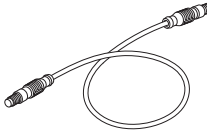
### Connection Cables between IO-Link Master Units

Name and appearance	Manufacturer	Specification	No. of cable conductors	Connector	Cable connection direction	Cable length	Model
Industrial Ethernet Connectors with Cable 	HARTING K.K.	M12 plug (D-coding, male) to M12 plug (D-coding, male)	4	Screw connector	Straight/straight	0.5 m	72MDm4MDm4005K
						1 m	72MDm4MDm4010K
						2 m	72MDm4MDm4020K
						3 m	72MDm4MDm4030K
						5 m	72MDm4MDm4050K
						10 m	72MDm4MDm4100K

## Power Supply Cables

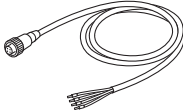
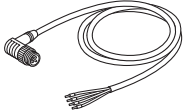
Power supply cables to connect the IO-Link master unit

Name and appearance	Manufacturer	Specification	No. of cable conductors	Connector	Cable connection direction	Cable length	Model
Connector with Cable (Socket on One End, Straight) 	HARTING K.K.	7/8 inch socket (female) to discrete wire	4	Screw connector	Straight	1 m	72MNf4010
						2 m	72MNf4020
						5 m	72MNf4050
						10 m	72MNf4100
Connector with Cable (Socket on One End, Right-angle) 					Right-angle	1 m	72MNfL4010
						2 m	72MNfL4020
						5 m	72MNfL4050
						10 m	72MNfL4100
Connectors with Cable (Socket on One End, Plug on Other End, Straight) 		Straight	1 m	72MNf4MNm4010			
			2 m	72MNf4MNm4020			
			5 m	72MNf4MNm4050			
			10 m	72MNf4MNm4100			
Connectors with Cable (Socket on One End, Plug on Other End, Right-angle) 		Right-angle	1 m	72MNfL4MNmL4010			
			2 m	72MNfL4MNmL4020			
			5 m	72MNfL4MNmL4050			
			10 m	72MNfL4MNmL4100			

Contact HARTING K.K. for details.

# NXR-ILM08C-EIT

## I/O Cables

- Conversion Cable

The following cable converts connections from an IO-Link device or non-IO-Link connected external device with an M8 plug.

Name and appearance	Manufacturer	Specification	No. of cable conductors	Connector	Cable connection direction	Cable length	Model
<p>XS3W Socket and Plug on Cable Ends (M8 (Socket)/M12 (Plug))</p>	OMRON	M8 socket (A-coding, female) to M12 plug (A-coding, male), DC type	4	(M8) screw connector, (M12) Smartclick connector *1	Straight	0.2 m	<b>XS3W-M42C-4C2-A</b>

\*1. Connectors for the IO-Link Master Unit are not Smartclick connector. Use a torque wrench for the I/O cable to tighten the connector. The Smartclick connector of the I/O cable can also be used as a screw connector.

- Direct connection or extension Cables

Extension cables, which connect an IO-Link device or standard external device with an M12 plug, can also be used to connect directly to an IO-Link device with an M12 plug.

Name and appearance	Manufacturer	Specification	No. of cable conductors	Connector	Cable connection direction	Cable length	Model
<p>XS2W Socket and Plug on Cable Ends (M12 (Socket)/M12 (Plug))</p>	OMRON	M12 socket (A-coding, female) to M12 plug (A-coding, male), DC type	4	Screw connector	Straight/straight	1 m	<b>XS2W-D421-C81-F</b>
						2 m	<b>XS2W-D421-D81-F</b>
						3 m	<b>XS2W-D421-E81-F</b>
						5 m	<b>XS2W-D421-G81-F</b>
						10 m	<b>XS2W-D421-J81-F</b>

- Branching

Name and appearance	Manufacturer	Specification	No. of cable conductors	Connector	Cable connection direction	Cable length	Model
<p>XS5R Y-Joint Plug/Socket Connector</p>	OMRON	M12	---	Smartclick Connector *1	---	---	<b>XS5R-D426-1</b>

\*1. Connectors for the IO-Link Master Unit are not Smartclick connector. Use a torque wrench for the I/O cable to tighten the connector.

## Waterproof Cover for Connectors

A waterproof cover for unused M12 connectors. When you use this waterproof cover, you can maintain the IP67 protective structure.

Name and appearance	Manufacturer	Specification	Connector	Model
<p>M12 Waterproof Cover</p>	OMRON	M12	Screw connector	<b>XS2Z-22</b>
<p>7/8 inch Waterproof Cover</p>	Molex	7/8 inch	Screw connector	<b>1302011110</b>

## General Specifications

Item		Specification
Degree of protection		IP67
Operating environment	Ambient operating temperature	-10 to 55°C
	Ambient operating humidity	25% to 85% (with no condensation)
	Ambient operating atmosphere	Must be free from corrosive gases.
	Storage temperature	-25 to 65°C
	Storage humidity	25% to 85% (with no condensation)
	Altitude	2,000 m max.
	Pollution degree	3 or less: Conforms to IEC 61010-2-201.
	Noise immunity	2 kV on power supply line (Conforms to IEC 61000-4-4.)
	Overvoltage category	Category II: Conforms to IEC 61010-2-201.
	EMC immunity level	Zone B
	Vibration resistance	10 to 60 Hz with amplitude of 0.35 mm, 60 to 150 Hz and 50 m/s <sup>2</sup> for 80 minutes each in X, Y, and Z directions.
	Shock resistance	150 m/s <sup>2</sup> , 3 times each in 6 directions along X, Y, and Z axes
	Dielectric strength	600 VAC (between isolated circuits)
Insulation resistance	20 MΩ min. (between isolated circuits)	
Applicable standards *1		cULus: Listed (UL61010-2-201) EU: EN 61131-2, RCM KC: KC Registration EAC IO-Link conformance EtherNet/IP conformance

\*1. Refer to the OMRON website ([www.ia.omron.com](http://www.ia.omron.com)) or ask your OMRON representative for the most recent applicable standards for each model.

## EtherNet/IP Communications Specifications

Item		Specification
Communications protocols		EtherNet/IP protocol <ul style="list-style-type: none"> <li>• Implicit messages (Class1)</li> <li>• Explicit messages (Class 3, UCMM)</li> </ul>
Modulation		Baseband
Link speed		10 Mbps or 100 Mbps
Ethernet physical layer		100BASE-TX or 10BASE-T (100BASE-TX is recommended.) *1
Ethernet switch		Layer-2 switch
Transmission media		Category 5 or higher twisted-pair cable (Recommended cable: double shielded cable with aluminum tape and braiding)
Transmission distance		100 m or less (Distance between nodes and between hub and node)
Topology		Line, Star, Tree, Ring
Number of connected Units		<ul style="list-style-type: none"> <li>• Line, Star No restrictions</li> <li>• Tree There is no restrictions in the number of cascade connections when an Ethernet switch is used.</li> <li>• Ring Dependent on the ring supervisor specifications.</li> </ul>
EtherNet/IP tag data links	Number of connections	5 *2
	Packet interval (RPI)	1 to 10,000 ms
	Allowed communications bandwidth per Unit	4,000 pps
Explicit messages	Class 3 (number of connections)	5 *2 However, the maximum number of connections per originator is 2
	UCMM (unconnected)	Supported *2
EtherNet/IP I/O connection size		Input: 296 bytes max. (including input data, status, and unused areas) Output: 258 bytes max. (including output data and unused areas)
Support functions	Supported services	Tag data link, CIP message communications, automatic clock adjustment (NTP/SNTP client), BOOTP client, DHCP client
	IP address duplication detection	Provided
	Run/Idle header	Supported *3
	QuickConnect	Supported
	DLR	Ring nodes supported

\*1. If tag data links are used, use 100BASE-TX.

\*2. The maximum number of connections is 10 when tag data links (Class 1), Class 3, and UCMM are used simultaneously.

\*3. You can configure output retention, clear, and other settings during Idle. Refer to the *NXR-series IO-Link Master Unit for EtherNet/IP™ User's Manual* (Cat.No.W619) for details.

## Unit Specifications

Item		Specification
IO-Link specifications	IO-Link connector type	Class A
	Communications protocol	IO-Link protocol
	Number of ports	8
	Baud rate	COM1: 4.8 kbps COM2: 38.4 kbps COM3: 230.4 kbps
	Topology	1:1
	Compliant standards	<ul style="list-style-type: none"> <li>IO-Link Interface and System Specification Version 1.1.2 *1</li> <li>IO-Link Test Specification Version 1.1.2</li> </ul>
	Cable specifications	<ul style="list-style-type: none"> <li>Cable type : Unshielded</li> <li>Cable length : 20 m max.</li> <li>Electrostatic capacity between lines : 3 nF max.</li> <li>Loop resistance : 6 Ω max.</li> </ul>
Unit/input power supply voltage		24 VDC (20.4 to 26.4 VDC)
Output power supply voltage		24 VDC (20.4 to 26.4 VDC)
Maximum power supply current		9 A Sum of Unit/input power supply current and output power supply current
Number of connected Units when supplying power with through-wiring		No restrictions if power supply specifications are met.
Mounting method		Mounting with M5 screws
Mounting strength		100 N
Installation orientation and restrictions		Installation orientation: 6 possible orientations Restrictions: No restrictions
Connector types		<ul style="list-style-type: none"> <li>EtherNet/IP communications connectors : M12 (D-coding, female) × 2</li> <li>Power supply connectors : 7/8 inch (male) × 1, 7/8 inch (female) × 1</li> <li>I/O connectors : M12 (A-coding, female) × 8</li> </ul>
Connector strength		30 N Applicable to all connectors
Screw tightening torque		<ul style="list-style-type: none"> <li>EtherNet/IP communications connectors and I/O connectors (M12 screw) : 0.5 to 0.6 N·m</li> <li>Power supply connectors (7/8 inch screw) : 1.5 to 1.7 N·m</li> <li>Unit mounting (M5 screw) : 1.47 to 1.96 N·m</li> <li>Rotary switch cover (M3 screw) : 0.4 to 0.6 N·m</li> <li>Waterproof covers for EtherNet/IP communications connectors (M12 screw) : 0.5 to 0.6 N·m</li> <li>Waterproof covers for power supply connectors (7/8 inch screw) : 1.5 to 1.7 N·m</li> </ul>
Maximum port current		4 A/port Total available current between pin 1 and pin 4
Device power supply *2 in IO-Link Mode or SIO (DI) Mode	Power supply used	Unit/input power supply
	Rated voltage	24 VDC (20.4 to 26.4 VDC)
	Maximum load current	2 A/pin
	Short-circuit protection	Provided *3
	Short-circuit detection	Provided *3
Digital inputs for pin 4 or digital inputs for pin 2 (in SIO (DI) Mode)	Power supply used	Unit/input power supply
	Rated voltage	24 VDC (20.4 to 26.4 VDC)
	Internal I/O common	PNP
	Input current	<ul style="list-style-type: none"> <li>Digital inputs for pin 2: 3.0 mA (at 24 VDC)</li> <li>Digital inputs for pin 4: 6.3 mA (at 24 VDC)</li> </ul>
	ON voltage/ON current	<ul style="list-style-type: none"> <li>Digital inputs for pin 2: 15 VDC min., 2 mA min.</li> <li>Digital inputs for pin 4: 15 VDC min., 3 mA min.</li> </ul>
	OFF voltage/OFF current	5 VDC max., 1 mA max.
	ON/OFF response time	1.0 ms max.
	Input filter time	No filter, 0.25 ms, 0.5 ms, 1 ms (default), 2 ms, 4 ms, 8 ms, 16 ms, 32 ms, 64 ms, 128 ms, 256 ms
	Short-circuit protection	Provided *3
Short-circuit detection	Provided *3	

# NXR-ILM08C-EIT

Item	Specification	
Digital outputs for pin 4 or digital outputs for pin 2 (in SIO (DO) Mode)	Power supply used	Output power supply
	Internal I/O common	PNP
	Output type	Open-drain
	Rated voltage	24 VDC (20.4 to 26.4 VDC)
	Maximum load current	2 A/pin
	Leakage current	0.1 mA max.
	Residual voltage	1.5 V max.
	ON/OFF response time	1.0 ms max.
	Short-circuit protection	Provided *4
	Short-circuit detection	Provided *4
Current consumption	Unit/input power supply	50 mA
	Output power supply	100 mA
Weight	440 g	
Dimensions	240 × 24.2 × 62 mm (W × H × D) (The height is 38 mm when the connectors are included.)	
Isolation method	No isolation	

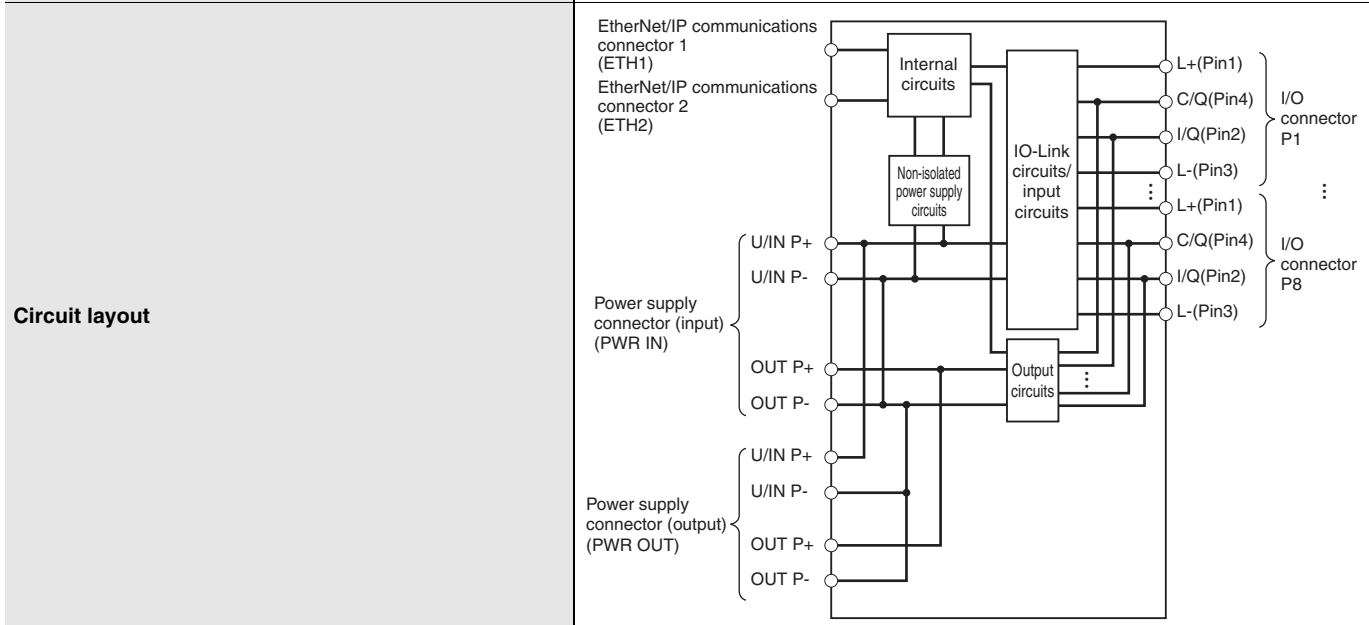

\*1. IO-Link PREOPERATE is not supported.

\*2. Used as a power supply for IO-Link devices or non-IO-Link input devices. Supplies power from the Unit/input power supply of the IO-Link Master Unit to external devices through I/O connectors.

\*3. Detects a short-circuit that occurred between pin 1 and pin 3 to protect the IO-Link Master Unit.

\*4. Detects a short-circuit that occurred between pin 2 and pin 3 and between pin 4 and pin 3 to protect the IO-Link Master Unit.

## Version Information

The following table shows the relationship between the unit versions of the IO-Link Master Unit and CPU unit, and the corresponding support software versions.

### Connecting with NJ/NX CPU Unit

#### NX-series CPU Unit

IO-Link Master Unit		Corresponding versions			
Model	Unit version	CPU unit version	Sysmac Studio	Network Configurator	CX-ConfiguratorFDT
NXR-ILM08C-EIT	Ver.1.1	Ver.1.14	Ver.1.40	Ver.3.69	Ver.2.54
	Ver.1.0				

#### NJ-series CPU Unit

IO-Link Master Unit		Corresponding versions				
Model	Unit version	CPU unit version	CJ1W-EIP21	Sysmac Studio	Network Configurator	CX-ConfiguratorFDT
NXR-ILM08C-EIT	Ver.1.1	Ver.1.14	Ver.2.1	Ver.1.40	Ver.3.69	Ver.2.54
	Ver.1.0					

### Connecting with CS/CJ/CP CPU Unit

#### CS1G/CS1H/CJ1M CPU Unit

IO-Link Master Unit		Corresponding versions			
Model	Unit version	CPU unit version	CS1W-EIP21/ CJ1W-EIP21	Network Configurator	CX-ConfiguratorFDT
NXR-ILM08C-EIT	Ver.1.1	Ver.3.0	Ver.2.1	Ver.3.69	Ver.2.54
	Ver.1.0				

#### CJ2H-CPU6□/CJ2M-CPU1□/CP1H CPU Unit

IO-Link Master Unit		Corresponding versions			
Model	Unit version	CPU unit version	CJ1W-EIP21	Network Configurator	CX-ConfiguratorFDT
NXR-ILM08C-EIT	Ver.1.1	Ver.3.0	Ver.2.1	Ver.3.69	Ver.2.54
	Ver.1.0				

#### CJ2H-CPU6□-EIP CPU Unit

IO-Link Master Unit		Corresponding versions			
Model	Unit version	CPU unit version	CJ1W-EIP21	Network Configurator	CX-ConfiguratorFDT
NXR-ILM08C-EIT	Ver.1.1	Ver.1.5	Ver.2.1	Ver.3.69	Ver.2.54
	Ver.1.0				

#### CJ2M-CPU3□ CPU Unit

IO-Link Master Unit		Corresponding versions			
Model	Unit version	CPU unit version	CJ1W-EIP21	Network Configurator	CX-ConfiguratorFDT
NXR-ILM08C-EIT	Ver.1.1	Ver.1.5	Ver.2.1	Ver.3.69	Ver.2.54
	Ver.1.0				

## External Interface

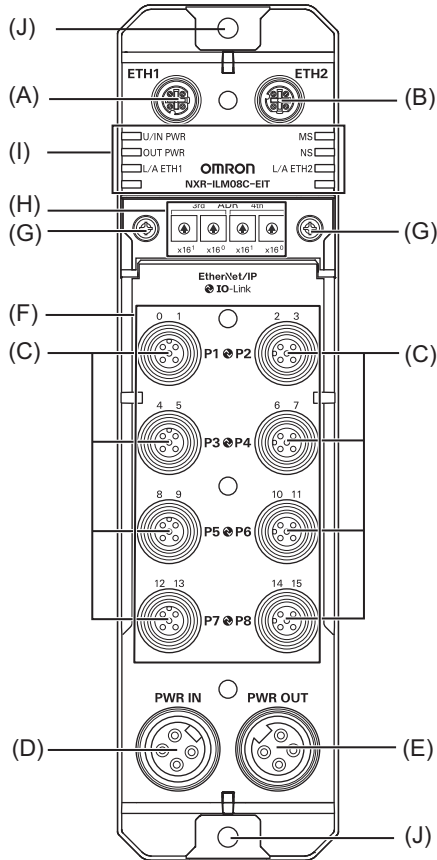

Letter	Name	Function
(A)	EtherNet/IP communications connector 1	The connector for EtherNet/IP port 1. <ul style="list-style-type: none"> <li>M12 connector (D-coding, female)</li> </ul> Connect a communications cable.
(B)	EtherNet/IP communications connector 2	The connector for EtherNet/IP port 2. <ul style="list-style-type: none"> <li>M12 connector (D-coding, female)</li> </ul> Connect a communications cable.
(C)	I/O connectors	The connectors for connecting IO-Link devices or non-IO-Link connected external devices. They are called "ports." <ul style="list-style-type: none"> <li>M12 connectors (A-coding, female)</li> </ul> Connect I/O cables.
(D)	Power supply connector (input)	The connector for supplying Unit/input power and output power. <ul style="list-style-type: none"> <li>7/8 inch connector (male)</li> </ul> Connect the power supply cable to an external power supply.
(E)	Power supply connector (output)	The connector for supplying Unit/input power and output power from the local node to another node. Use this connector when the power supply method is power supply with through-wiring. <ul style="list-style-type: none"> <li>7/8 inch connector (female)</li> </ul> Connect the power supply cable to an additional IO-Link Master Unit.
(F)	I/O indicators	The indicators that show the I/O status of pin 4/pin 1 and pin 2 for each port.
(G)	Cover mounting holes	The screw holes for mounting the rotary switch cover. They are provided in two locations. The above figure shows the holes when the cover is mounted with screws.
(H)	Rotary switches	The switches for setting the IP address.
(I)	Status indicators	The indicators that show the current operating status of the Unit.
(J)	Unit mounting holes	The holes for mounting the Unit. They are provided in two locations. Mount the Unit with M5 screws.

Dimensions

(Unit: mm)

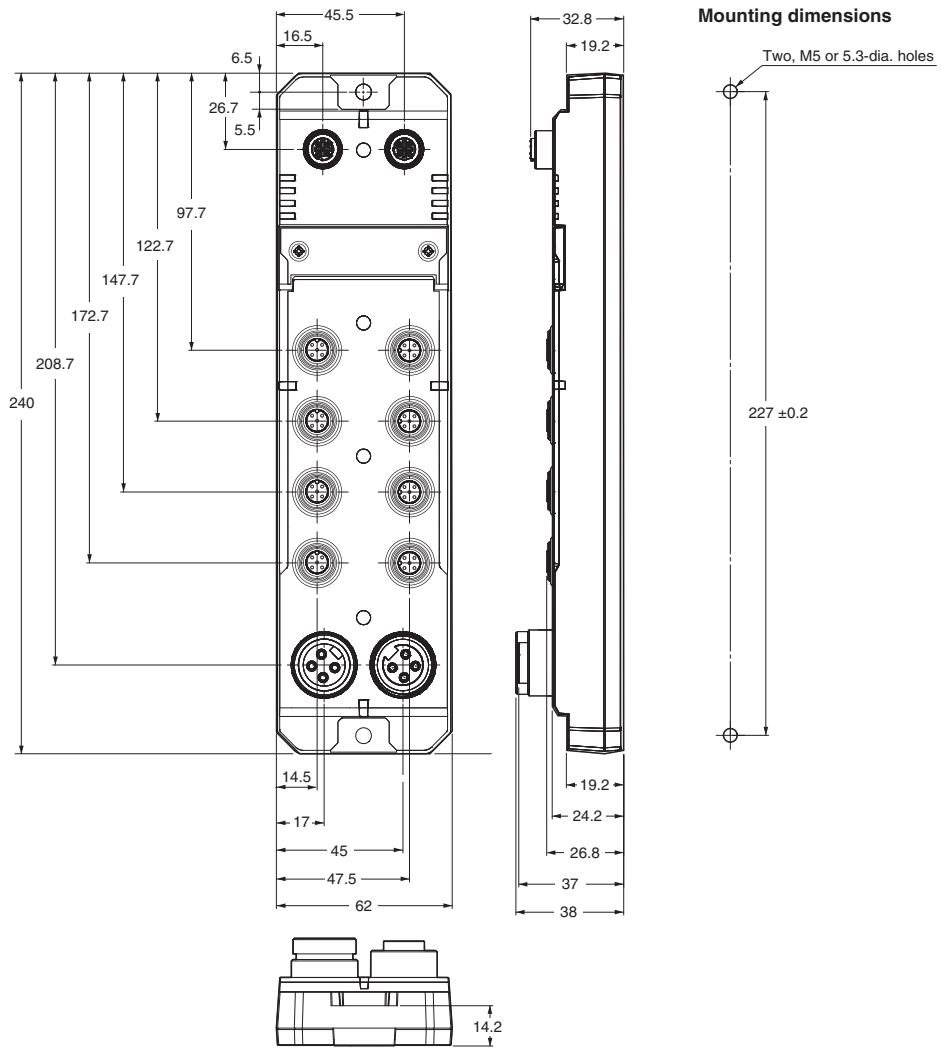

## Wiring Example for I/O connectors

### Wiring Example for IO-Link Devices

#### Wiring Example for IO-Link Devices (with Digital Inputs for Pin 2)

A wiring example for an IO-Link device with digital inputs for pin 2 is shown below.

In this example, the port is used in the following communications modes.

Pin 4: IO-Link Mode, pin 2: SIO (DO) Mode

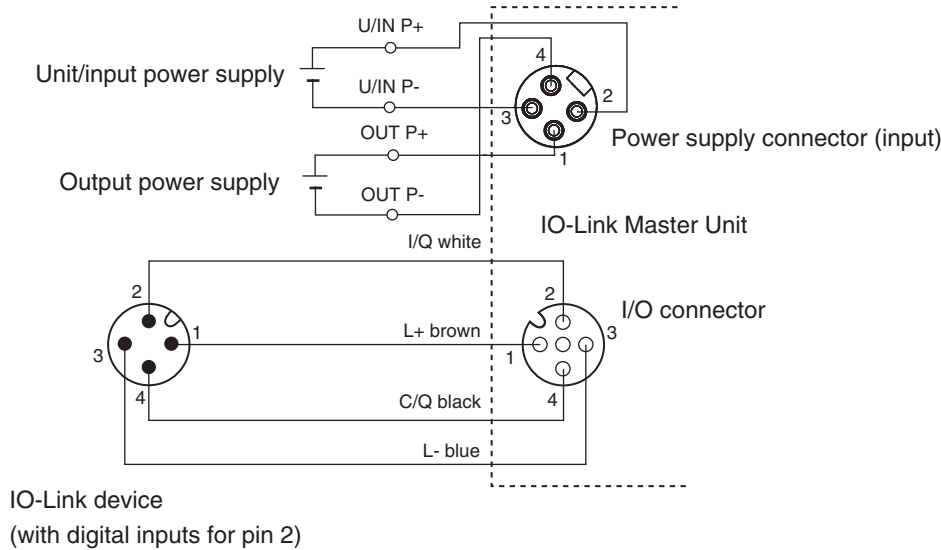

#### Wiring Example for IO-Link Devices (with Digital Outputs for Pin 2)

A wiring example for an IO-Link device with digital outputs for pin 2 is shown below.

In this example, the port is used in the following communications modes.

Pin 4: IO-Link Mode, pin 2: SIO (DI) Mode

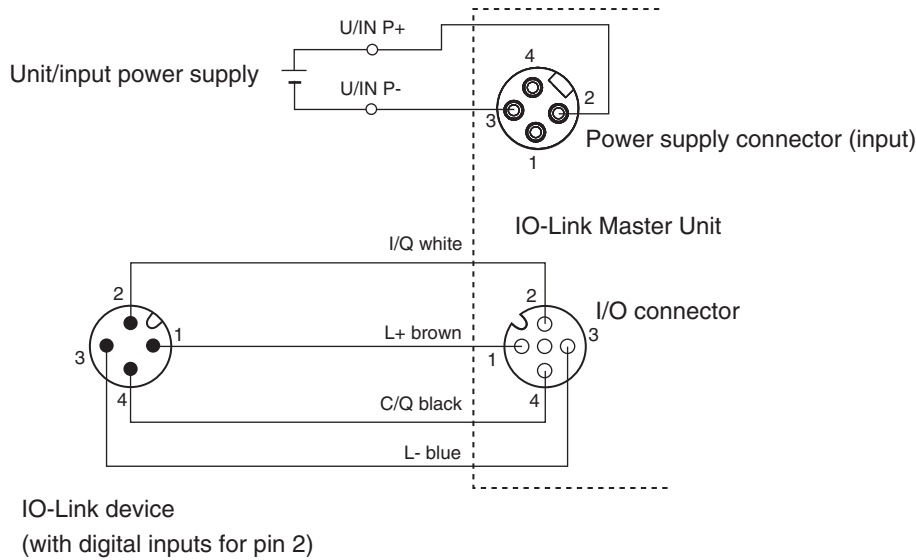

**Wiring Example for IO-Link Devices (without Digital Inputs and Outputs for Pin 2)**

A wiring example for an IO-Link device without digital inputs and outputs for pin 2 is shown below. In this example, the port is used in the following communications modes.

Pin 4: IO-Link Mode, pin 2: Disabled

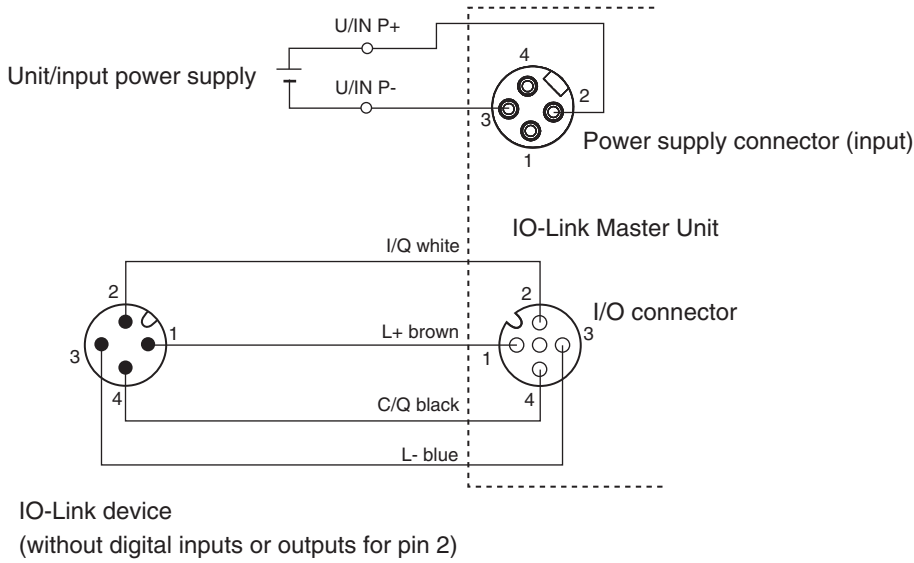

## Wiring Example for Non-IO-Link Input Devices

### Wiring Example for Three-wire Sensors

In this example, the port is used in the following communications modes.

Pin 4: SIO (DI) Mode, pin 2: Disabled

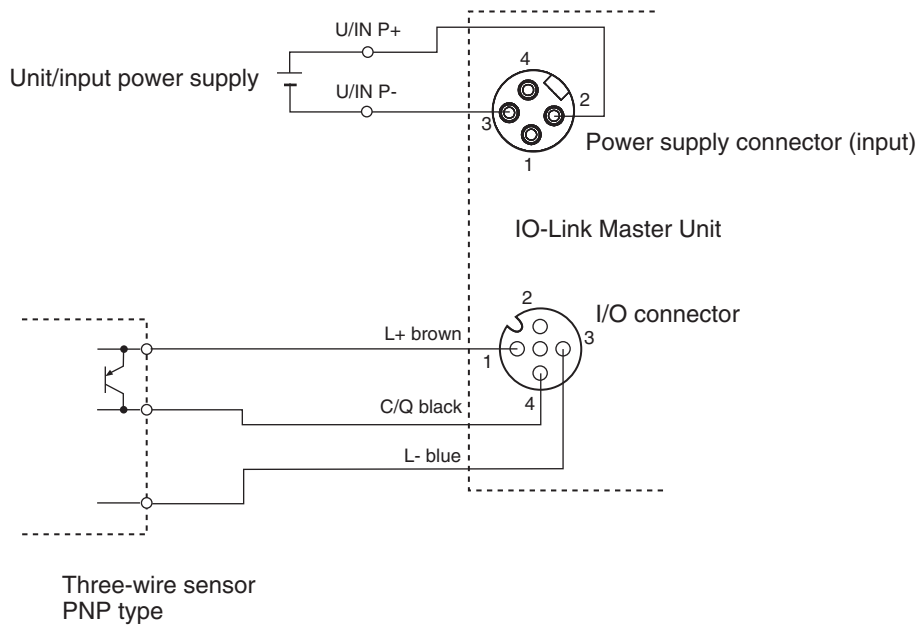

### Wiring Example for Two-wire Sensors

In this example, the port is used in the following communications modes.

Pin 4: SIO (DI) Mode, pin 2: Disabled

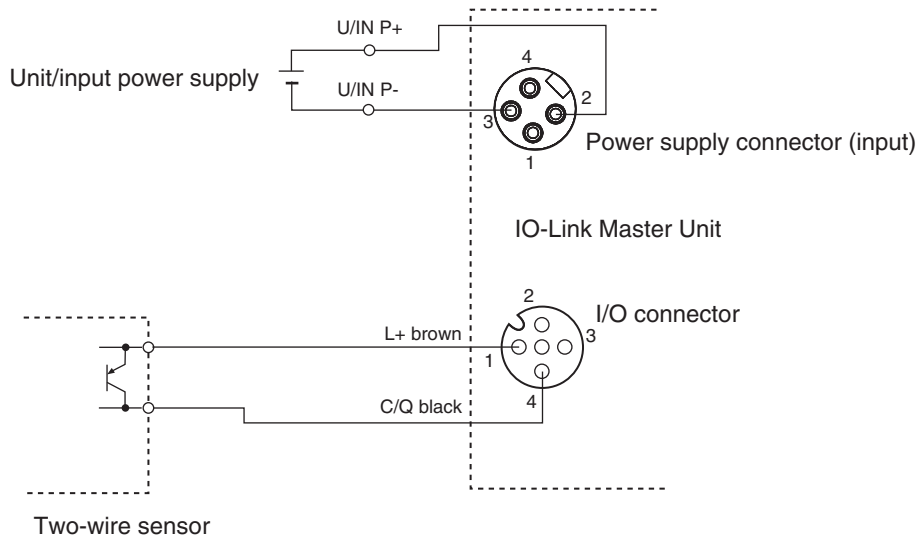

## Wiring Example for Non-IO-Link Output Devices

A wiring example between the IO-Link Master Unit and a non-IO-Link output device is shown below.  
In this example, the port is used in the following communications modes.

Pin 4: SIO (DO) Mode, pin 2: Disabled

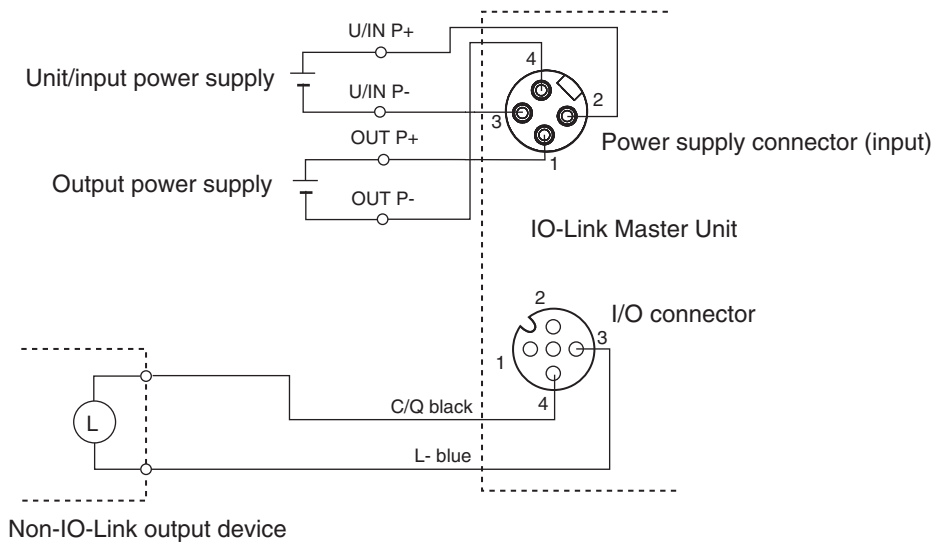

# NXR-ILM08C-EIT

## Power Supply System

There are two methods to supply power to IO-Link Master Units as shown below.

### Direct power supply

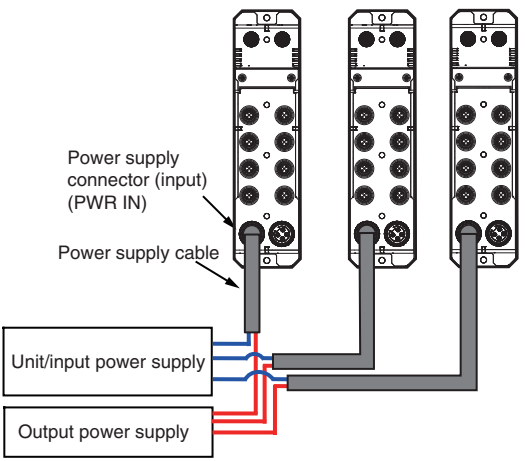
Description	Feature
<p>Connect the external power supplies to the power supply connector (input) of each IO-Link Master Unit. The power supply connector (output) is not used.</p> 	<p>This method does not cause voltage drop in through-wiring cables or due to connection through IO-Link Master Units.</p>

An example is shown below.

Connect the external power supplies to the power supply connector (input) of each IO-Link Master Unit.

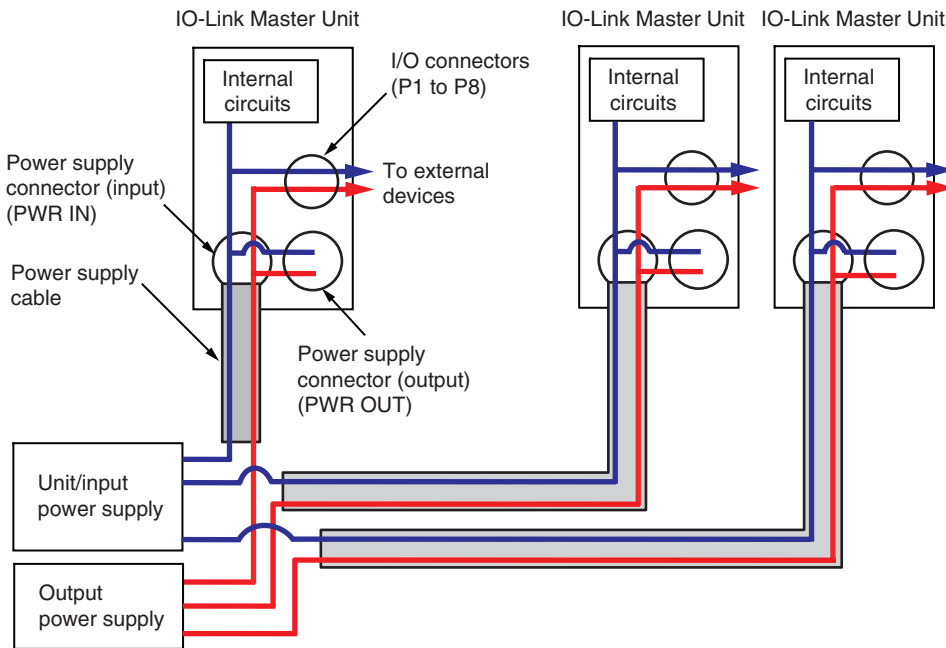

**Power supply with through wiring**

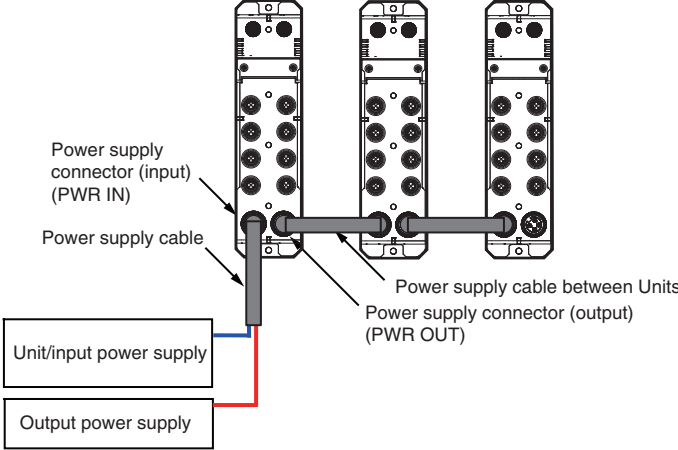
Description	Feature
<p>Connect the external power supplies to the power supply connector (input) of one IO-Link Master Unit. Then, connect the power supply connector (output) of the Unit to the power supply connector (input) of another IO-Link Master Unit with a power supply cable. In this way, supply power with through-wiring between the subsequent Units with power supply cables. The power supply connector (output) is used.</p> 	<p>Through-wiring can reduce the overall length of the power supply cables used in the system.</p>

An example is shown below.

Connect the external power supplies to the power supply connector (input) of one IO-Link Master Unit.

Then, connect the power supply connector (output) of the Unit to the power supply connector (input) of another IO-Link Master Unit with a power supply cable.

In this way, connect a power supply cable between the subsequent Units with through-wiring one after another.

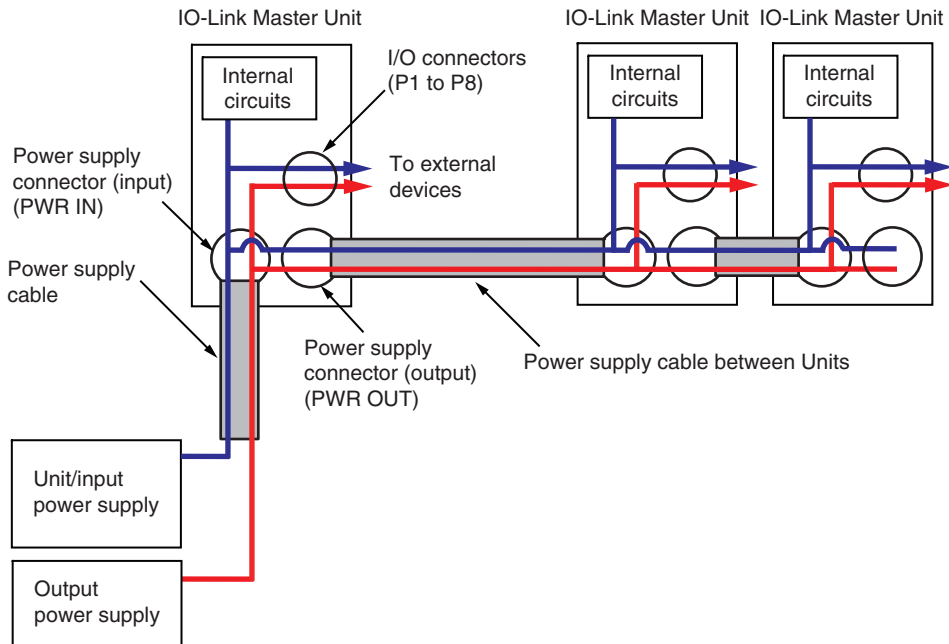

# NXR-ILM08C-EIT

## Related Manuals

Manual	Cat. No	Model	Application	Description
NXR-series IO-Link Master Unit for EtherNet/IP™ User's Manual	W619	NXR-ILM08C-EIT	Learning how to use an NXR-series IO-Link Master Unit for EtherNet/IP.	Describes the hardware, setup methods, and functions of the NXR-series IO-Link Master Unit for EtherNet/IP.
NXR-series IO-Link I/O Hub User's Manual	W620	NXR-□□□□□□-IL□	Learning how to use an NXR-series IO-Link I/O Hub.	Describes the hardware, setup methods, and functions of the NXR-series IO-Link I/O Hub.
NJ/NX-series CPU Unit Built-in EtherNet/IP™ Port User's Manual	W506	NX701-□□□□ NJ501-□□□□ NJ301-□□□□ NJ101-□□□□ NX102-□□□□ NX1P2-□□□□	Using the built-in EtherNet/IP port on an NJ/NX-series CPU Unit.	Information on the built-in EtherNet/IP port is provided. Information is provided on the basic setup, tag data links, and other features.
CS/CJ-series EtherNet/IP™ Units Operation Manual	W465	CS1W-EIP21 CJ1W-EIP21 CJ2H-CPU6□-EIP CJ2M-CPU3□	Using the CS/CJ-series EtherNet/IP Unit.	Provides information on operating and installing CS/CJ-series EtherNet/IP Units, including details on basic settings, tag data links, and FINS communications.
Sysmac Studio Version 1 Operation Manual	W504	SYSMAC-SE2□□□□	Learning about the operating procedures and functions of the Sysmac Studio.	Describes the operating procedures of the Sysmac Studio.
NJ/NX-series Instructions Reference Manual	W502	NX701-□□□□ NJ501-□□□□ NJ301-□□□□ NJ101-□□□□ NX102-□□□□ NX1P2-□□□□	Learning detailed specifications on the basic instructions of an NJ/NX-series CPU Unit.	The instructions in the instruction set (IEC 61131-3 specifications) are described.
IO-Link Sensor Index List	9541795-1	E3Z-□8□-IL□	Learning the vendor IDs, device IDs, I/O data (process data), and objects (service data).	Describes the following details for OMRON's IO-Link sensors. <ul style="list-style-type: none"> <li>• IO-Link physical layer</li> <li>• Device IDs</li> <li>• Process data</li> <li>• Service data</li> <li>• Event functions</li> </ul>
	9540292-0	E2E(Q)-□-IL□		
	9539397-1	E3S-DCP21-IL□		

Sysmac is a trademark or registered trademark of OMRON Corporation in Japan and other countries for OMRON factory automation products. Microsoft and Windows are either registered trademarks or trademarks of Microsoft Corporation in the United States and/or other countries. EtherCAT® is a registered trademark and patented technology, licensed by Beckhoff Automation GmbH, Germany. EtherNet/IP™ is a trademark of ODVA. Other company names and product names in this document are the trademarks or registered trademarks of their respective companies.

**OMRON AUTOMATION AMERICAS HEADQUARTERS** • Chicago, IL USA • 847.843.7900 • 800.556.6766 • automation.omron.com

**OMRON CANADA, INC. • HEAD OFFICE**

Toronto, ON, Canada • 416.286.6465 • 866.986.6766 • automation.omron.com

**OMRON ELECTRONICS DE MEXICO • HEAD OFFICE**

Ciudad de México • 52.55.5901.4300 • 01.800.386.6766 • mela@omron.com

**OMRON ELECTRONICS DE MEXICO • SALES OFFICE**

San Pedro Garza García, N.L. • 81.12.53.7392 • 01.800.386.6766 • mela@omron.com

**OMRON ELECTRONICS DE MEXICO • SALES OFFICE**

Eugenio Garza Sada, León, Gto • 01.800.386.6766 • mela@omron.com

**OMRON ELETRÔNICA DO BRASIL LTDA • HEAD OFFICE**

São Paulo, SP, Brasil • 55 11 5171-8920 • automation.omron.com

**OMRON ARGENTINA • SALES OFFICE**

Buenos Aires, Argentina • +54.11.4521.8630 • +54.11.4523.8483  
mela@omron.com

**OTHER OMRON LATIN AMERICA SALES**

+54.11.4521.8630 • +54.11.4523.8483 • mela@omron.com

*Authorized Distributor:*

**Controllers & I/O**

- Machine Automation Controllers (MAC) • Motion Controllers
- Programmable Logic Controllers (PLC) • Temperature Controllers • Remote I/O

**Robotics**

- Industrial Robots • Mobile Robots

**Operator Interfaces**

- Human Machine Interface (HMI)

**Motion & Drives**

- Machine Automation Controllers (MAC) • Motion Controllers • Servo Systems
- Frequency Inverters

**Vision, Measurement & Identification**

- Vision Sensors & Systems • Measurement Sensors • Auto Identification Systems

**Sensing**

- Photoelectric Sensors • Fiber-Optic Sensors • Proximity Sensors
- Rotary Encoders • Ultrasonic Sensors

**Safety**

- Safety Light Curtains • Safety Laser Scanners • Programmable Safety Systems
- Safety Mats and Edges • Safety Door Switches • Emergency Stop Devices
- Safety Switches & Operator Controls • Safety Monitoring/Force-guided Relays

**Control Components**

- Power Supplies • Timers • Counters • Programmable Relays
- Digital Panel Meters • Monitoring Products

**Switches & Relays**

- Limit Switches • Pushbutton Switches • Electromechanical Relays
- Solid State Relays

**Software**

- Programming & Configuration • Runtime