



Datasheet

RS PRO LOUVERED FILTER FAN KIT WITH 254mm AC AXIAL FAN INSTALLED and SNAP-ON GUARD

Stock number: 175-9840

EN

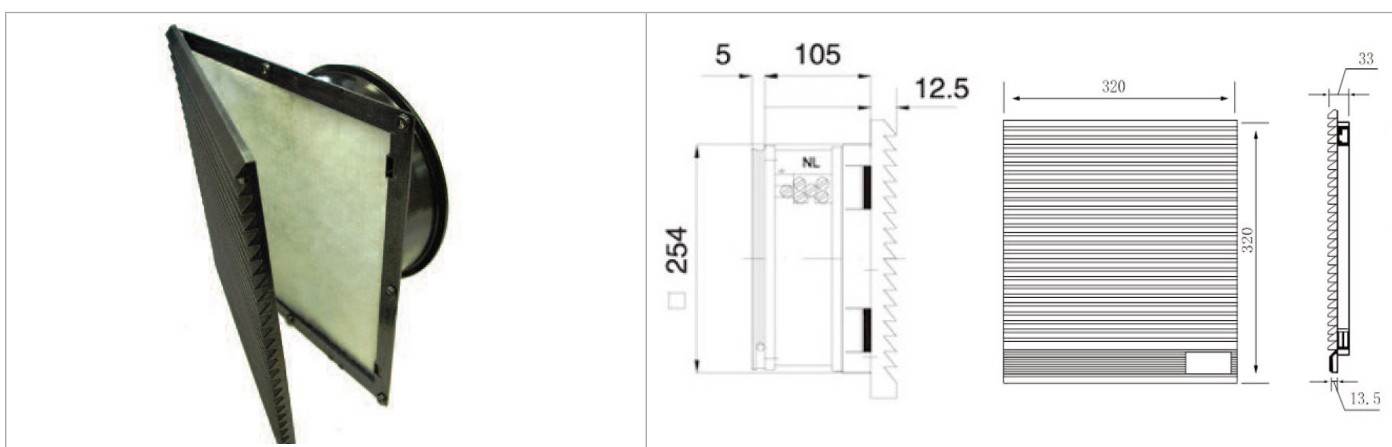

Frame	Diecast Aluminum	<u>Operating Temperature</u> Ball Bearing -40C - +70C
Impeller	PBT, UL94V-O plastic	<u>Life Expectancy</u> Ball Bearing 60,000 hours (L10 at 40C)
Connection	Wire Leads	<u>Environmental Protection</u> Class B Insulation Rated IP54 Guard
Motor	Capacitor Drive, Impedance protected	Guard Frame: ABS Resin UL94V-O with UV protection
Bearing System	Dual ball bearing	Color: Black (standard) or Gray
Insulation Resistance	>100M ohm between lead- wire and frame (500VDC)	Filter Mesh: Nylon fiber Synthetic Resin
Dielectric Strength	1 min at 1500 VAC, 50/60Hz	

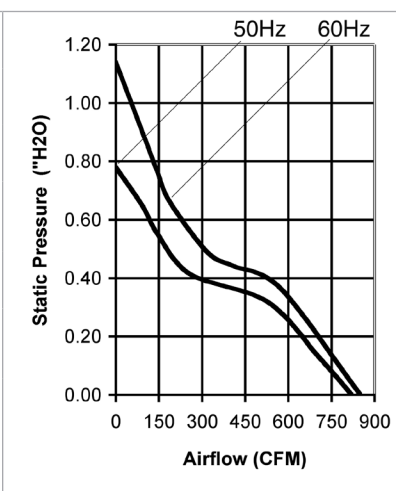

Model Number	175-9840
Nominal Voltage	230 VAC
Voltage Range	160-260 VAC
Rated Power	75 W (60Hz)
Rated Speed (RPM)	2700
Airflow - CFM	850
Noise Level - (dB)	69
Max. Static Pressure	0.78" H ₂ O

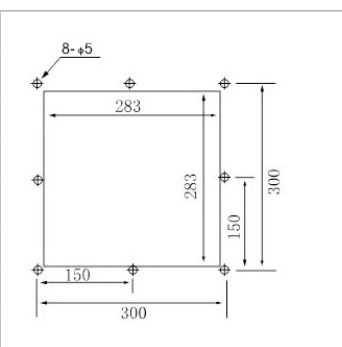

* Note: Airflow data is for the fan without the louvered filter attached. Calculations indicate that up to a 40% reduction (~ 180 CFM) in fan airflow is possible with LFG unit installed.