



**SERIES 340 WEDGE TAINER**

**RECOMMENDED TORQUE**

80 N-cm (7 in-lbs)

**WEIGHT**

2.65 g/cm (.224 oz/in)

**MATERIALS AND FINISH**

**WEDGES AND HOUSING**

**Material:** Aluminum Alloy 6061-T6 per ASTM-B221 or AMS-QQ-A-200/8

**Finish:** See finish table on opposite page

**SCREW**

.09-in. or 2.5-mm hex. socket head cap screw, depending on mounting configuration

**Material:** Series 300 stainless steel per Se QQ-S-763 ASTM A-582

**Finish:** Passivated per AMS2700

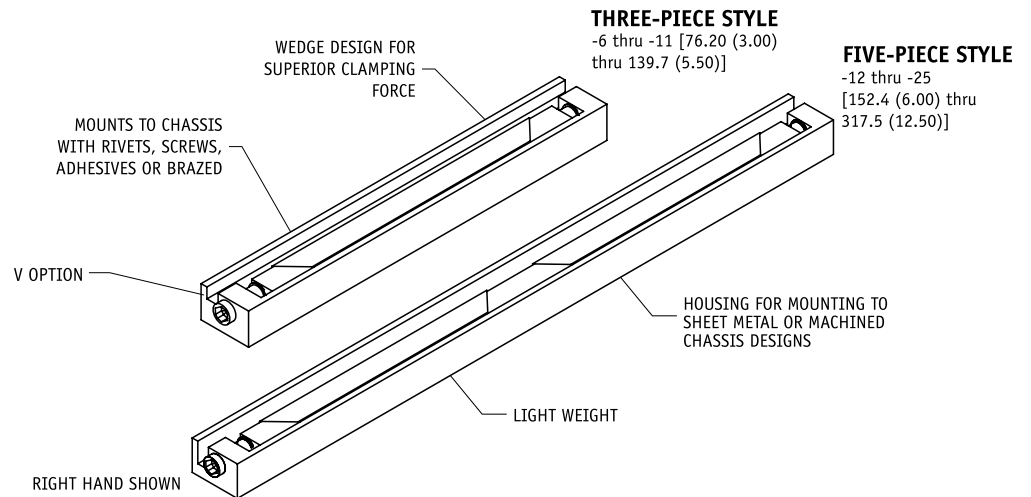

# SERIES 340 WEDGE TAINER

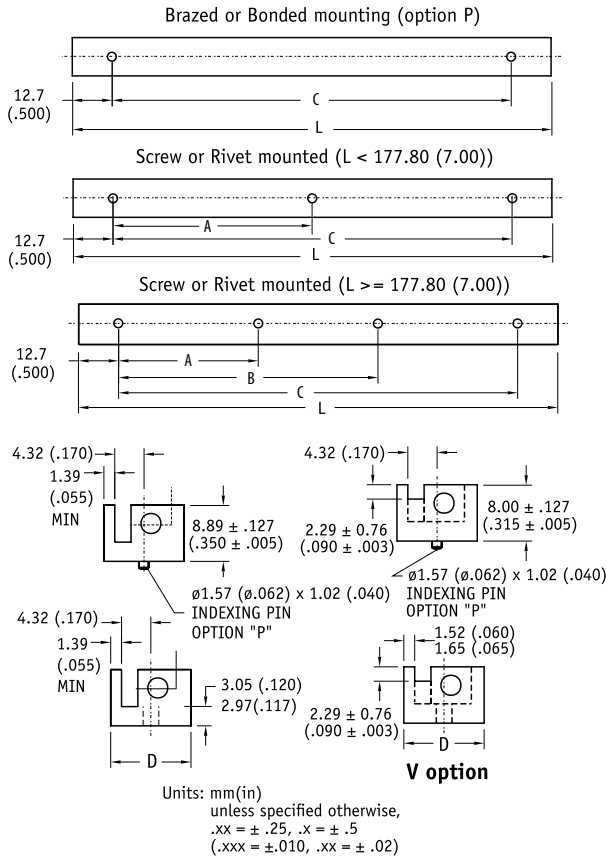

MOUNTING DIMENSIONS TABLE							
-6 THRU -11 ARE THREE-PIECE, -12 AND UP ARE FIVE-PIECE							
DASH #	L	A	B	NUMBER OF HOLES			
				C	TAPPED	RIVET	BRAZED
-06	3.00 (76.20)	1.000 (25.40)	---	2.000 (50.80)	3	3	2
-07	3.50 (88.90)	1.250 (31.75)	---	2.500 (63.50)	3	3	2
-08	4.00 (101.60)	1.500 (38.10)	---	3.000 (76.20)	3	3	2
-09	4.50 (114.30)	1.750 (44.45)	---	3.500 (88.90)	3	3	2
-10	5.00 (127.00)	2.000 (50.80)	---	4.000 (101.60)	3	3	2
-11	5.50 (139.70)	2.250 (57.15)	---	4.500 (114.30)	3	3	2
-12	6.00 (152.40)	2.500 (63.50)	---	5.000 (127.00)	3	3	2
-13	6.50 (165.10)	2.750 (69.85)	---	5.500 (139.70)	3	3	2
-14	7.00 (177.80)	2.000 (50.80)	4.000 (101.60)	6.000 (152.40)	4	4	2
-15	7.50 (190.60)	2.250 (57.15)	4.250 (107.95)	6.500 (165.10)	4	4	2
-16	8.00 (203.30)	2.250 (57.15)	4.750 (120.65)	7.000 (177.80)	4	4	2
-17	8.50 (216.00)	2.500 (63.50)	5.000 (127.00)	7.500 (190.60)	4	4	2
-18	9.00 (228.70)	2.500 (63.50)	5.500 (139.70)	8.000 (203.30)	4	4	2
-19	9.50 (241.40)	2.750 (69.85)	5.750 (146.05)	8.500 (216.00)	4	4	2
-20	10.00 (254.10)	3.000 (76.20)	6.000 (152.40)	9.000 (228.70)	4	4	2
-21	10.50 (266.80)	3.250 (82.55)	6.250 (158.75)	9.500 (241.40)	4	4	2
-22	11.00 (279.50)	3.250 (82.55)	6.750 (171.45)	10.000 (254.10)	4	4	2
-23	11.50 (292.20)	3.500 (88.90)	7.000 (177.80)	10.500 (266.80)	4	4	2
-24	12.00 (304.90)	3.500 (88.90)	7.500 (190.50)	11.000 (279.50)	4	4	2
-25	12.50 (317.60)	3.750 (95.25)	7.750 (196.85)	11.500 (292.20)	4	4	2

**Part Number Code**  
**Series 340 & Series V340 WEDGE-TAINER**

V for eurocard style board like VME or cPCI **V**  
 or not **[Blank]**

**Screw Action**  
 Left hand **L**  
 Right hand **R**

**Board Thickness**  
 1.52 (.060) - 2.39 (.094) **100**  
 Or choose from board thickness table

**Mounting Method**  
 4-40 UNC02B tapped holes **S**  
 Or choose from mounting table

**Length**  
 Length in 12.7 (.500) increments **06 [76.2 (3.00)]**  
**to 25 [317.5 (12.50)]**

**Finish**  
 Black Anodized **B**  
 Or choose from finish table

**Part Number Code example: 340L-100M-12N**

Series 340 WEDGE-TAINER, left handed, for 1.52- 2.39 mm (.060-.094-in.) thick board, M3 metric screw mounting, 152.4-mm (6.00-in.) long, nickel plate finish.

BOARD THICKNESS TABLE		
DASH #	THICKNESS	D
-100	+/- .127 (.005)	+/- .127 (.005)
-150	1.52 (.060) - 2.39 (.094)	12.19 (.480)
-175	2.79 (.95) - 3.68 (.145)	13.46 (.530)
-175	3.30 (.130) - 4.19 (.165)	13.46 (.530)

MOUNTING METHOD TABLE	
CODE LETTER	METHOD
R	RIVET MOUNT (Ø2.48 (.098) THRU √ Ø4.55 (.179) X 100°)
A	NO MOUNTING HOLES
S	4-40 UNC-2B TAPPED HOLE
M	M3 X .50 TAPPED HOLE
NOTE:	RIVET (R) PARTS ARE SHIPPED UNASSEMBLED

FINISH TABLE	
CODE LETTER	SURFACE FINISH
C	CHEMICAL FILM PER MIL-C-5541, CLASS 1A, GOLD, NON ROHS COMPLIANT
CC	CHEMICAL FILM PER MIL-C-5541, CLASS 1A, CLEAR
EN	ELECTROLESS NICKEL PER MIL-C-26074, CLASS 4, GRADE B, BRIGHT
N	NICKEL PLATE PER QQ-N-290, CLASS 1, GRADE G, BRIGHT
B	BLACK ANODIZE PER MIL-A-8625, TYPE II, CLASS 2
B3	HARD BLACK ANODIZE PER MIL-A-8625, TYPE III, CLASS 2
B3D	HARD BLACK ANODIZE WITH DRY FILM LUBE PER MIL-L46010



**SCHROFF**

nVent may modify standard parts without prior notice to or approval from customers. These modifications may change product appearance, but will not have a detrimental effect on form, fit or function. ©2018 nVent. All nVent marks and logos are owned or licensed by nVent Services GmbH or its affiliates. All other trademarks are the property of their respective owners. nVent reserves the right to change specifications without notice.