

# E20722

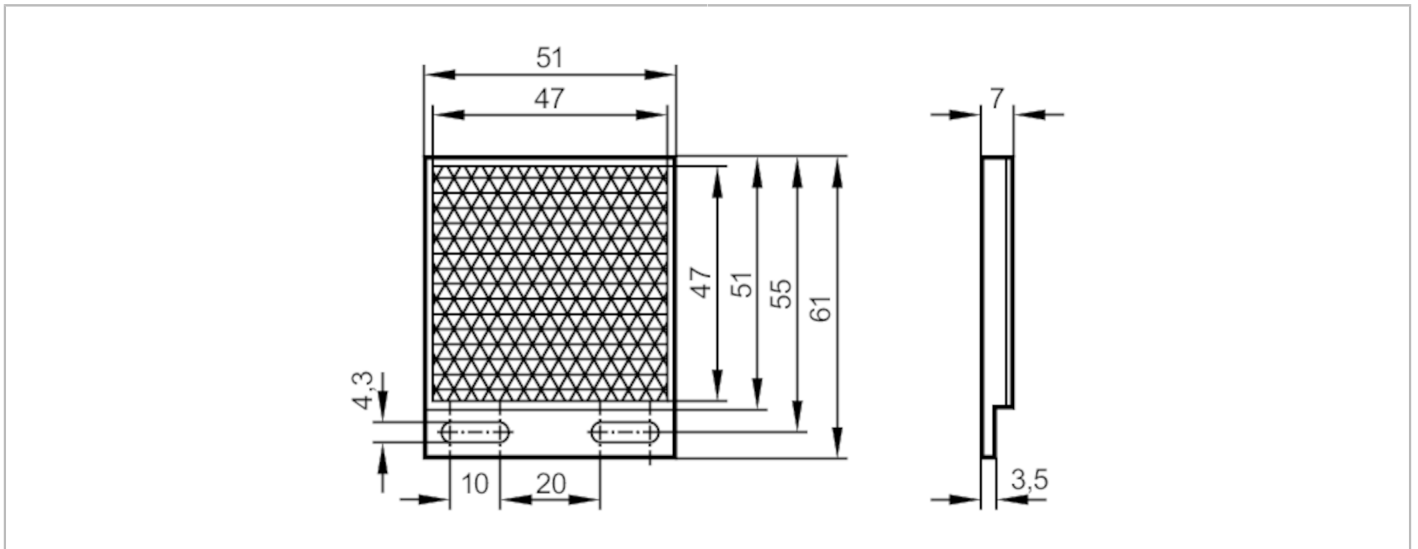

## Reflector for retro-reflective laser sensors

REFLECTOR LASER TS-48X48



### Application

Design rectangular, for retro-reflective laser sensors and glass and film detection

### Operating conditions

Ambient temperature [°C] -10...60

### Mechanical data

Weight [g]	13.9
Dimensions [mm]	61 x 51 x 7
Reflector surface [mm]	47 x 47
Material	plastics

### Remarks

Pack quantity 1 pcs.