

FEATURES

- 17.5 mm width
- DIN Rail mounting
- Off delay timing function
- Integrated dual voltage
- LED indications for power and relay status
- Wide supply voltage range
- IP20 (terminals), IP40 (enclosure) protection
- Offers a “one stop solution” for your power management system
- The two LED status indicators indicate status at a glance

RS PRO SPDT Timer Relay - 0.3 s → 30 h, 1 Contacts, OFF Delay, DIN Rail

RS Stock No.: 896-6829



RS Professionally Approved Products bring to you professional quality parts across all product categories. Our product range has been tested by engineers and provides a comparable quality to the leading brands without paying a premium price.

Product Description

RS PRO Off delay time delay relay is a dual voltage, single function timer that is compact in size and suitable for DIN Rail mounting.

General Specifications

Switch Configuration	SPDT
Mode of Operation	Off Delay
Contact Configuration	CO
Number of Timer Functions	Single
Number of Contacts	1
Time Range	0.3s to 30h
Time Increment	Seconds
Power on indication / Timing	Green LED
Relay Status	Red LED
Applications	Production, Safety, On-delay timers, Off-delay timers, Interval-on-operate, Flasher, Repeat cycle

Electrical Specifications

Power Supply	External
Supply Voltage	24V ac/dc, 110V ac
Minimum Voltage	12VAC/DC
Maximum Voltage	24V ac/dc, 110V ac
Current Maximum	5A
Current Minimum	0.1A
Relay Output	SPCO
Terminal Type	Screw

Mechanical Specifications

Mounting Type	DIN-Rail
Depth	58.5 mm
Width	90 mm
Length	17.5 mm

Operation Environment Specifications

Maximum Operating Temperature	55°C
Minimum Operating Temperature	-10°C

Protection Category

IP Rating	IP20; IP40
-----------	------------

Approvals

Compliance/Certifications	CE, RoHS
---------------------------	----------







ELECTRONIC TIME RELAYS

RS Stock No's:
ON-Delay
896-6810 & 896-6816
Star-Delta Starter Timer
896-6832, 896-6835 & 896-6838
Signal OFF-Delay
896-6822 & 896-6829

Terminal Details:

	1.1 Nm (10 lb.in)
Ø3.5.....5.0mm	Terminal screw - M3.5
	2 x 0.2...2.5 mm ² solid wire
AWG	1 x 24 to 10

AWG	CURRENT (A)
10	5.00
12	4.38
14	3.75
16	3.13
18	2.50
20	1.88
22	1.25
24	0.63

NOTE: Use Cu Wire of 75 Dec. C Only..

Models :

ON-Delay 896-6810 & 896-6816
Star-Delta Starter Timer 896-6832, 896-6835 & 896-6838
Signal OFF-Delay 896-6822 & 896-6829

Installation :

DIN - Rail Mounting : The Timer should be mounted on 35 mm symmetrical DIN - Rail.

On Delay Timer

896-6810 & 896-6816

Timing Diagram:

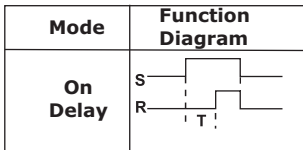

STAR - DELTA START Timer:

RS Stock No 896-6835 & 896-6838

Timing Diagram:

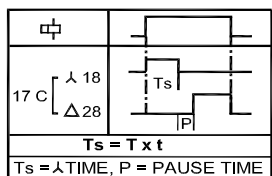

Signal Off Delay Timer

896-6822 & 896-6829

Timing Diagram :

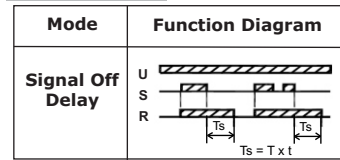

Connection Diagrams :

896-6822 & 896-6829

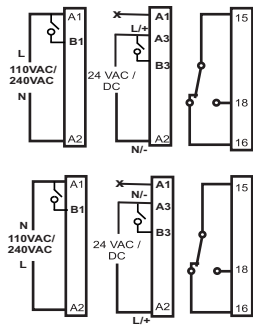

Do not apply more than 27VAC/DC to A3 terminal.

Connection Diagrams :

896-6810

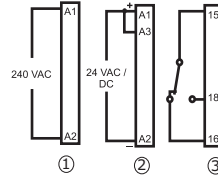

896-6816

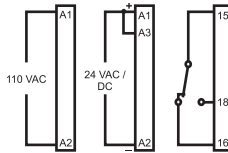

896-6838 Un = 240VAC

896-6835 Un = 110VAC

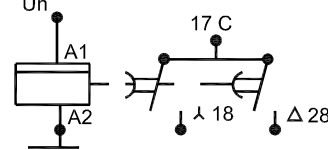

CONNECTION DIAGRAM FOR 896-6832

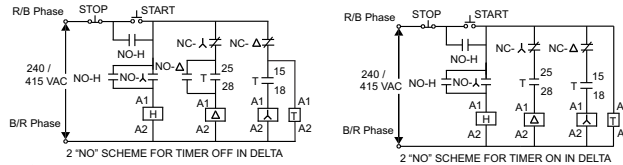

Use only with above given wiring diagram.

Sensor Connection Diagrams For 896-6822 & 896-6829

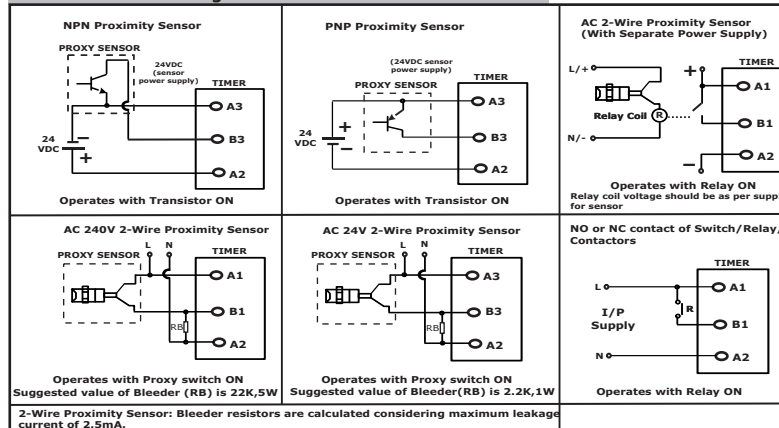

2-Wire Proximity Sensor: Bleeder resistors are calculated considering maximum leakage current of 2.5mA.

Recommended Star - Delta Control Circuit :

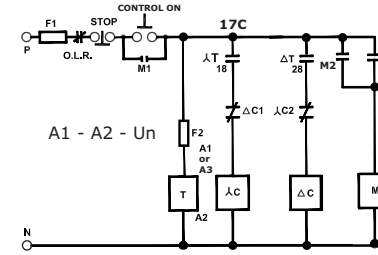

- 1) F1 - Mains Protection Fuse
- 2) F2 - Timer Protection Fuse
- 3) O.L.R - Over Load Relay
- 4) M1 - First 'NO' Contact of Main Contactor
- 5) M2 - Second 'NO' Contact of Main Contactor
- 6) M - Main Contactor for driving Motor
- 7) λC - Star Contactor
- 8) λC1 - 'NO' Contact of Star Contactor
- 9) λC2 - 'NC' Contact of Star Contactor
- 10) ΔC - Delta Contactor
- 11) λC1 - 'NC' Contact of Delta Contactor
- 12) λT - Star Contact of Timer (λ-Δ)
- 13) ΔT - Delta Contact of Timer (λ-Δ)
- 14) T - Star Delta Timer (λ-Δ)

Caution :

1. Always follow instructions stated in this product leaflet.
2. Before installation, check that the specifications agree with the intended application.
3. Installation to be done by skilled electrician.
4. Changing Range and Timing Presets in power ON condition when the On Delay period has already started, will have no effect. It has to be set before powering ON the timer.
5. If user wants to reset timer one way to do this is to switch off the timer & then set timing & range preset to required position. In this case, Timer will reset & will take new set time.
6. Setting of all the potentiometers should be in clockwise direction only.
7. Use 250 mA slow blow fuse (F2) in series with the above mentioned products.
8. The timers shall be placed in an enclosure that is minimum 200% of the size of the timer in the end use application. Use Cu wire of 75°C for connections.
9. The technical information provided in this document is correct at the time of going to the press. Product innovation being a continuous process, we reserve the right to make any alteration without prior notice.

Overall Dimension :

Base Mounting :

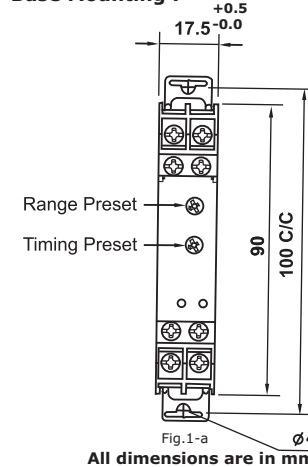

All dimensions are in mm

Din Rail Mounting :

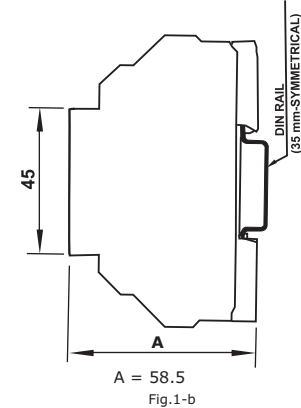

A = 58.5