



SERIES 340 WEDGE TAINER

RECOMMENDED TORQUE

80 N-cm (7 in-lbs)

WEIGHT

2.65 g/cm (.224 oz/in)

MATERIALS AND FINISH

WEDGES AND HOUSING

Material: Aluminum Alloy 6061-T6 per ASTM-B221 or AMS-QQ-A-200/8

Finish: See finish table on opposite page

SCREW

.09-in. or 2.5-mm hex. socket head cap screw, depending on mounting configuration

Material: Series 300 stainless steel per Se QQ-S-763 ASTM A-582

Finish: Passivated per AMS2700

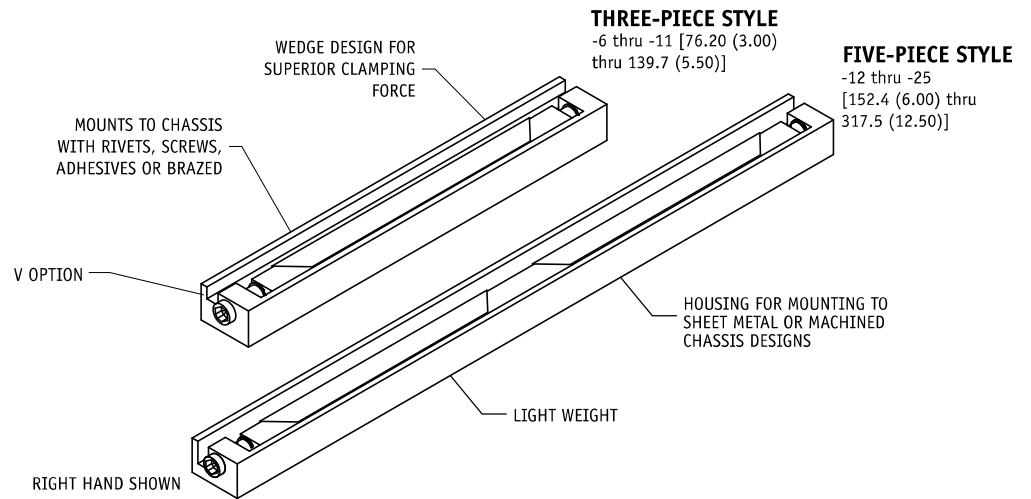

SERIES 340 WEDGE TAINER

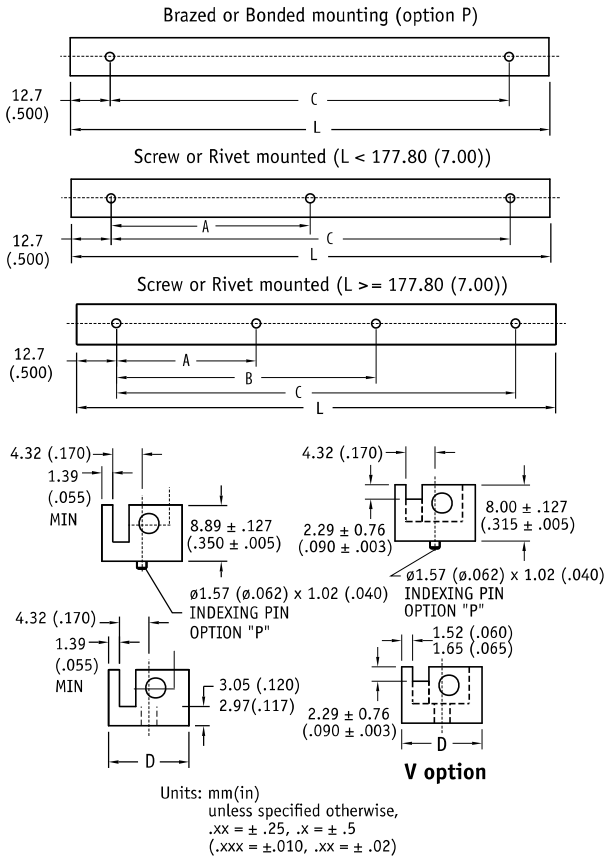

DASH #	L	A	B	NUMBER OF HOLES			
				C	TAPPED	RIVET	BRAZED
				-6 THRU -11 ARE THREE-PIECE, -12 AND UP ARE FIVE-PIECE			
-06	3.00 (76.20)	1.000 (25.40)	---	2.000 (50.80)	3	3	2
-07	3.50 (88.90)	1.250 (31.75)	---	2.500 (63.50)	3	3	2
-08	4.00 (101.60)	1.500 (38.10)	---	3.000 (76.20)	3	3	2
-09	4.50 (114.30)	1.750 (44.45)	---	3.500 (88.90)	3	3	2
-10	5.00 (127.00)	2.000 (50.80)	---	4.000 (101.60)	3	3	2
-11	5.50 (139.70)	2.250 (57.15)	---	4.500 (114.30)	3	3	2
-12	6.00 (152.40)	2.500 (63.50)	---	5.000 (127.00)	3	3	2
-13	6.50 (165.10)	2.750 (69.85)	---	5.500 (139.70)	3	3	2
-14	7.00 (177.80)	2.000 (50.80)	4.000 (101.60)	6.000 (152.40)	4	4	2
-15	7.50 (190.60)	2.250 (57.15)	4.250 (107.95)	6.500 (165.10)	4	4	2
-16	8.00 (203.30)	2.250 (57.15)	4.750 (120.65)	7.000 (177.80)	4	4	2
-17	8.50 (216.00)	2.500 (63.50)	5.000 (127.00)	7.500 (190.60)	4	4	2
-18	9.00 (228.70)	2.500 (63.50)	5.500 (139.70)	8.000 (203.30)	4	4	2
-19	9.50 (241.40)	2.750 (69.85)	5.750 (146.05)	8.500 (216.00)	4	4	2
-20	10.00 (254.10)	3.000 (76.20)	6.000 (152.40)	9.000 (228.70)	4	4	2
-21	10.50 (266.80)	3.250 (82.55)	6.250 (158.75)	9.500 (241.40)	4	4	2
-22	11.00 (279.50)	3.250 (82.55)	6.750 (171.45)	10.000 (254.10)	4	4	2
-23	11.50 (292.20)	3.500 (88.90)	7.000 (177.80)	10.500 (266.80)	4	4	2
-24	12.00 (304.90)	3.500 (88.90)	7.500 (190.50)	11.000 (279.50)	4	4	2
-25	12.50 (317.60)	3.750 (95.25)	7.750 (196.85)	11.500 (292.20)	4	4	2

Part Number Code
Series 340 & Series V340 WEDGE-TAINER

V for eurocard style board like VME or cPCI _____ **V**
 or not _____ [Blank]

Screw Action
 Left hand _____ **L**
 Right hand _____ **R**

Board Thickness
 1.52 (.060) - 2.39 (.094) _____ **100**
 Or choose from board thickness table

Mounting Method
 4-40 UNC02B tapped holes _____ **S**
 Or choose from mounting table

Length
 Length in 12.7 (.500) increments _____ **06 [76.2 (3.00)]**
 _____ **to 25 [317.5 (12.50)]**

Finish
 Black Anodized _____ **B**
 Or choose from finish table

Part Number Code example: 340L-100M-12N
 Series 340 WEDGE-TAINER, left handed, for 1.52- 2.39 mm (.060-.094-in.) thick board, M3 metric screw mounting, 152.4-mm (6.00-in.) long, nickel plate finish.

BOARD THICKNESS TABLE

DASH #	THICKNESS	D
-100	+/- .127 (.005)	+/- .127 (.005)
-150	1.52 (.060) - 2.39 (.094)	12.19 (.480)
-175	2.79 (.95) - 3.68 (.145)	13.46 (.530)
-175	3.30 (.130) - 4.19 (.165)	13.46 (.530)

MOUNTING METHOD TABLE

CODE LETTER	METHOD
R	RIVET MOUNT (Ø2.48 (.098) THRU √ Ø4.55 (.179) X 100°)
A	NO MOUNTING HOLES
S	4-40 UNC-2B TAPPED HOLE
M	M3 X .50 TAPPED HOLE
NOTE:	RIVET (R) PARTS ARE SHIPPED UNASSEMBLED

FINISH TABLE

CODE LETTER	SURFACE FINISH
C	CHEMICAL FILM PER MIL-C-5541, CLASS 1A, GOLD, NON ROHS COMPLIANT
CC	CHEMICAL FILM PER MIL-C-5541, CLASS 1A, CLEAR
EN	ELECTROLESS NICKEL PER MIL-C-26074, CLASS 4, GRADE B, BRIGHT
N	NICKEL PLATE PER QQ-N-290, CLASS 1, GRADE G, BRIGHT
B	BLACK ANODIZE PER MIL-A-8625, TYPE II, CLASS 2
B3	HARD BLACK ANODIZE PER MIL-A-8625, TYPE III, CLASS 2
B3D	HARD BLACK ANODIZE WITH DRY FILM LUBE PER MIL-L46010



SCHROFF