

BD1-SERIES

BD1-Series

BATTERY DISCONNECT POWER SWITCH

Carling Technologies BD1-Series battery disconnect switch is designed to minimize battery drain, ensure maintenance personnel safety. Additionally, the optional, removable key adds an extra layer of security to protect against vehicle theft.

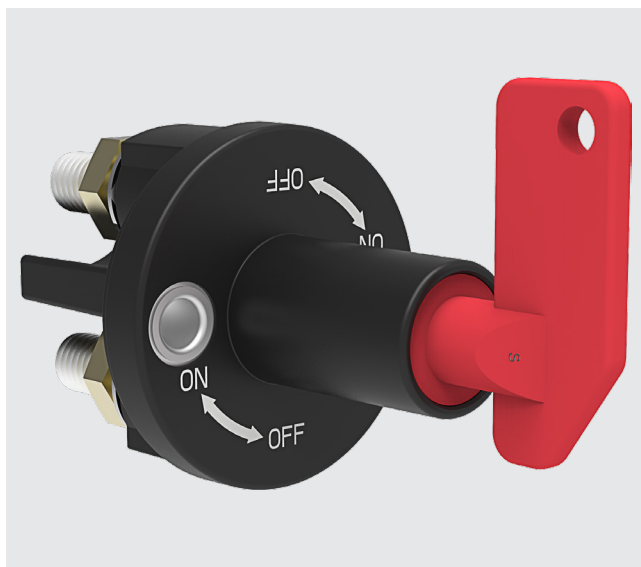

Resources:

[Configure a Complete Part](#)

[Download CAD & Sales Drawing >](#)

[Watch Product Video](#)



Product Highlights:

- 250 Amps
- 12 or 24VDC
- Permanent or Removable Key Options
- IP67 Sealing Protection
- Choice of 19mm or 27mm Length Studs

Typical Applications:

- On/Off-Highway Equipment
- Military
- Marine



Carling Technologies®
Innovative Designs. Powerful Solutions.

Carling Technologies, Inc.
60 Johnson Avenue, Plainville, CT 06062
Email: sales@carlingtech.com
Application Support: team2@carlingtech.com
Phone: 860.793.9281 Fax: 860.793.9231

www.carlingtech.com

BD1-Series

DESIGN FEATURES

OFF POSITION

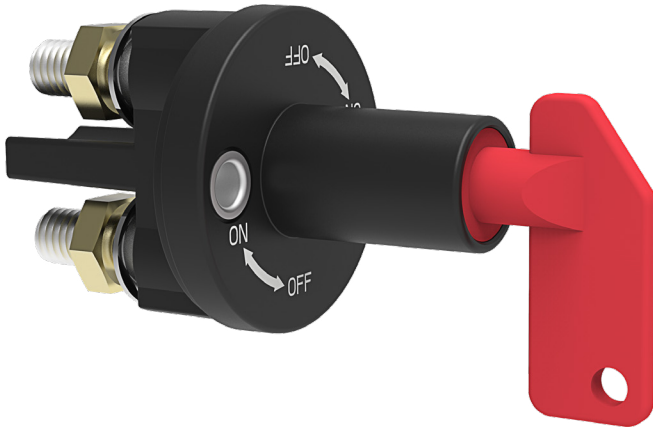

ON POSITION

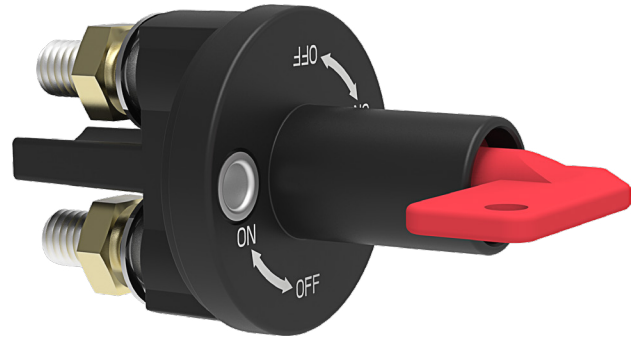

OFF POSITION WITH KEY REMOVED

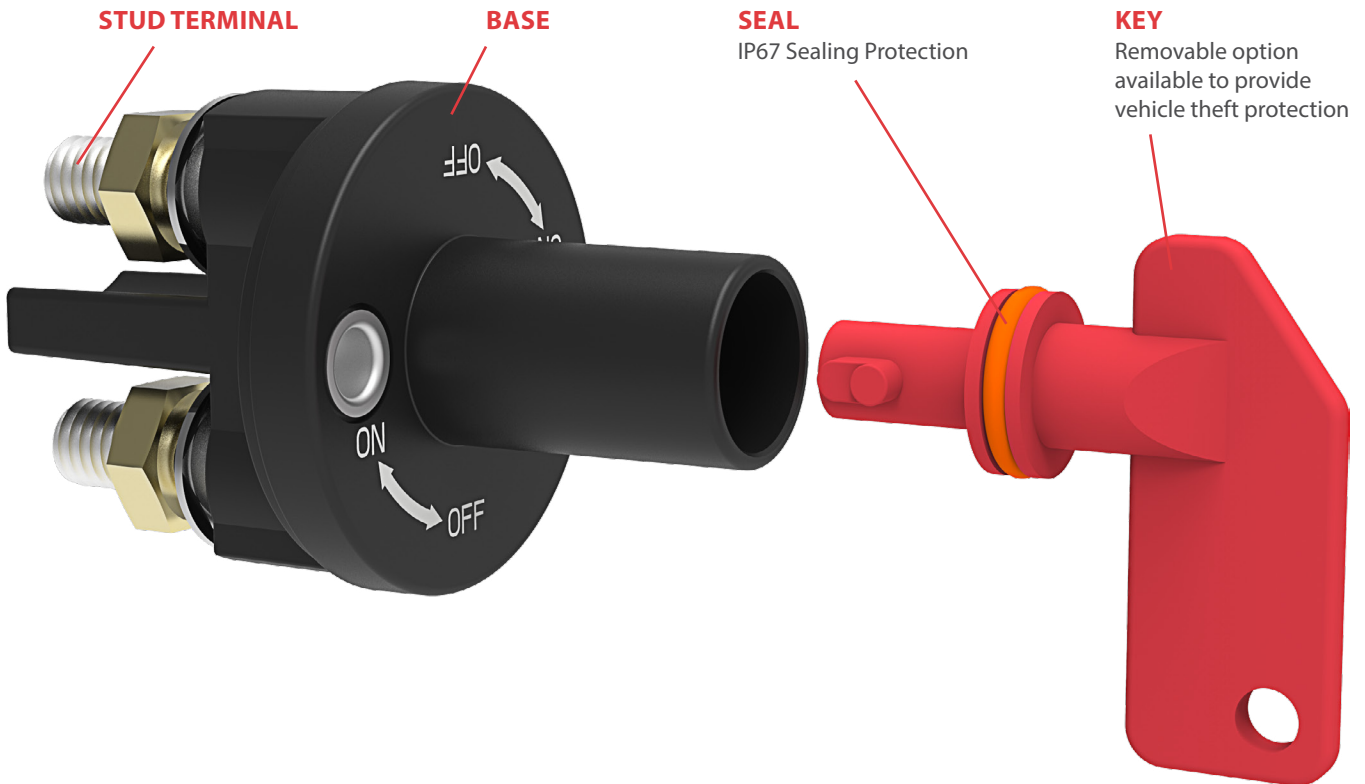

Electrical

Application Voltage	DC Rated voltage: 12VDC / 24VDC Range of operating voltage: 12VDC: min 9VDC, max 16VDC; 24VDC: min 18VDC, max 32VDC
Current Ratings	250A@ 12VDC/24VDC
Contact Voltage Drop	Voltage drop \leq 100mV after 300 sec. ON at 200% rated current prior to endurance test; Voltage drop \leq 500mV after 5 msec. ON at 1600A max. current prior to endurance test.
Dielectric Strength	50HZ, 1200VAC for 1 minute between electrically / isolated terminals in main circuit; between terminals of main circuit, knob and enclosure.
Insulation Resistance	Minimum of 100 Megohms 1 min @ 500VDC.
Temperature Rise	Terminal should not exceed 90°C above ambient at rated current after endurance test.
Endurance	2 seconds ON and 3 seconds OFF per operation, load with rated current & voltage. 12V test @ 14V; 24V test @ 28V. Total 20,000 cycles: 250A current ratings, including 4,000 cycles respectively at -40 °C \pm 2 and +85 °C \pm 2; 12,000 cycles at 23 °C \pm 2.
Overload	500A: 300 seconds ON; 1600A: 30 seconds ON.

Mechanical

Handling Shock	Fully functional after 3 drops from 1000 mm height. Surface damage may occur.
Endurance	Minimum 50,000 cycles without load.

Environmental

Operating Temp.	-40 °C to +85 °C.
Moisture Resistance	IEC 60068-2-38 or G/T 2423.34, Test Z/AD: Composite temperature/humidity cycle test, ten 24-hour cycles @ -10°C to +65°C, \leq 80-96% RH.
Thermal Cycling	IEC 60068-2-14 or GB/T 2423.22, Test Nb, 25 Cycles -40°C to +85°C.
Thermal Shock	GB/T 28046.4-2011, 5.3.2, Test Na (100 cycles @ -40°C to +25°C to +85°C to +25°C).
Thermal Resistance	ISO 16750-4 or GB/T 28046.4 Cold: Test A, work 24 hours @ -40°C ISO 16750-4 or GB/T 28046.4 Heat: Test B, work 48 hours @ +85°C.
Vibration	IEC 60068-2-34 or GB/ T 2423.11, 10-500 Hz, Random vibration test for 8 hours in each of the 3 mutually perpendicular axes. 25Gs @ Z axes, 12.5Gs @ X/Y axes, powered.
Salt Spray	IEC 60068-2-11 or GB/T 2423.17, 48 hours.
Fire and Smoke	IEC 60695-11-10 or GB/T 2408, HB (horizontal burning) and V0 (vertical burning).
Sealing	IEC 60529 or GB4208, IP 67
Chemical Splash	Gasoline, Diesel, Motor Oil, Brake Fluid, Ammonia, Mixture of previous five chemicals.
UV Protection	ASTM G155-05a, cycle 11, 300 hr Xenon Arc, 1.4W / (m ² Nm), wavelength 420 Nm.

Physical

Number of Poles	1 pole
Wiring Terminals	Line / Load terminal: brass nuts Torque value: M10 (10-15 Nm).
Mounting	M6/M7 bolt and nut, torque value: 4-5 Nm.
Torque Operation	0.5-1.0 Nm.
Body Color	Black
Actuator Color	Red
Weight	Approximately 165g
Material	Base & Bracket & Key (glass filled nylon), Studs (Tin plated brass), Nuts (Brass) Locking Washers (SUS304).

*Manufacturer reserves the right to change product specification without prior notice.
GPS-0010 Rev: B

BD1 - 1 A 2

1 Series 2 Rating 3 Key Style 4 Termination

1 SERIES
BD1 Battery Disconnect Power Switch (1 Pole)

2 RATING / CYCLES
1 250A @ 12/24VDC

3 KEY STYLE
A Removable¹
B Non-Removable

4 TERMINATION
1 M10 Stud 19 mm length
2 M10 Stud 27 mm length

Notes:
 1 Individual Keys separately available, reference part number 308-39943-001.

Dimensional Specifications: in. [mm]

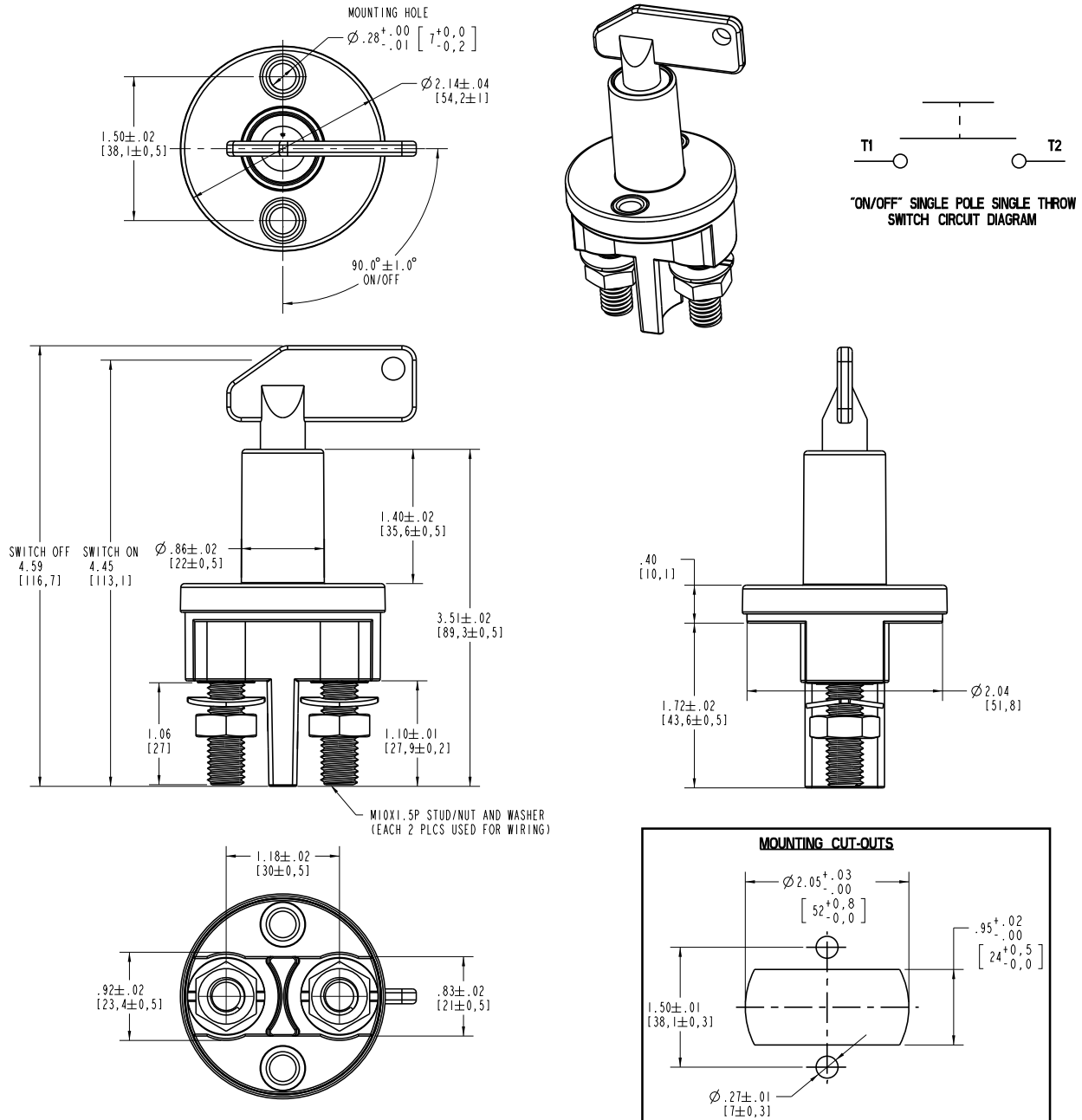

Notes:
 1 Torque for mounting nut: M6 or M7 (4-5 nm)
 2 Torque for wiring nut: M10 (10-15 nm)
 3 Switch can be mounted vertically or horizontally

COA-0099 Rev: A
 CLA-0154 Rev: A

Authorized Sales Representatives and Distributors

Click on a region of the map below to find your local representatives and distributors or visit www.carlingtech.com/findarep.



About Carling

Founded in 1920, Carling Technologies is a leading manufacturer of electrical and electronic switches and assemblies, circuit breakers, electronic controls, power distribution units, and multiplexed power distribution systems. With four ISO registered manufacturing facilities and technical sales offices worldwide, Carling Technologies Sales, Service and Engineering teams do much more than manufacture electrical components, they engineer powerful solutions! To learn more about Carling please visit www.carlingtech.com/company-profile.

To view all of Carling's environmental, quality, health & safety certifications please visit www.carlingtech.com/environmental-certifications

Worldwide Headquarters

Carling Technologies, Inc.
60 Johnson Avenue, Plainville, CT 06062
Phone: 860.793.9281 **Fax:** 860.793.9231
Email: sales@carlingtech.com

Northern Region Sales Office: nrsm@carlingtech.com
Southeast Region Sales Office: sersm@carlingtech.com
Midwest Region Sales Office: mrsm@carlingtech.com
West Region Sales Office: wrsm@carlingtech.com
Latin America Sales Office: larsm@carlingtech.com

Asia-Pacific Headquarters

Carling Technologies, Asia-Pacific Ltd.,
Suite 1607, 16/F Tower 2, The Gateway,
Harbour City, 25 Canton Road,
Tsimshatsui, Kowloon, Hong Kong
Phone: Int + 852-2737-2277 **Fax:** Int + 852-2736-9332
Email: sales@carlingtech.com.hk

Shenzhen, China: shenzhen@carlingtech.com
Shanghai, China: shanghai@carlingtech.com
Pune, India: india@carlingtech.com
Kaohsiung, Taiwan: taiwan@carlingtech.com
Yokohama, Japan: japan@carlingtech.com

Europe | Middle East | Africa Headquarters

Carling Technologies LTD
4 Airport Business Park, Exeter Airport,
Clyst Honiton, Exeter, Devon, EX5 2UL, UK
Phone: Int + 44 1392.364422 **Fax:** Int + 44 1392.364477
Email: ltd.sales@carlingtech.com

Germany: gmbh@carlingtech.com
France: sas@carlingtech.com



Carling Technologies®

Innovative Designs. Powerful Solutions.