



Air Cylinder Series *NCM*

Stainless Steel Body Cylinders

7/16", 9/16", 3/4", 7/8", 1-1/16", 1-1/4", 1-1/2", 2" Bore



**Now available in
7/16" and 9/16" bore**

Double Rod/Double End Mounting
Non-rotating Rod Option
Auto Switch Capable

Standard type	Actuation	Style	Auto switch capable	Non-rotating rod	With bumper	Bore size	Standard stroke (inch)
	Double acting	Single rod	<input type="checkbox"/>	<input type="checkbox"/>	<input type="checkbox"/>	044 (7/16") 056 (9/16") 075 (3/4") 088 (7/8") 106 (1-1/16") 125 (1-1/4") 150 (1-1/2") 200 (2")	[Bore size 044/056] 0050 (1/2"), 0100 (1"), 0150 (1-1/2"), 0200 (2"), 0250 (2-1/2"), 0300 (3"), 0400 (4") [Bore size 075 and above] 0050 (1/2"), 0100 (1"), 0150 (1-1/2"), 0200 (2"), 0250 (2-1/2"), 0300 (3"), 0400 (4"), 0600 (6")
	Double acting	Double rod	<input type="checkbox"/>	<input type="checkbox"/>	<input type="checkbox"/>	075 (3/4") 088 (7/8") 106 (1-1/16") 125 (1-1/4") 150 (1-1/2") 200 (2")	0050 (1/2"), 0100 (1"), 0150 (1-1/2"), 0200 (2"), 0250 (2-1/2"), 0300 (3"), 0400 (4"), 0600 (6")
	Single acting	Single rod	<input type="checkbox"/>	<input type="checkbox"/>	<input type="checkbox"/>	075 (3/4") 088 (7/8") 106 (1-1/16") 125 (1-1/4") 150 (1-1/2")	0050 (1/2"), 0100 (1"), 0200 (2"), 0300 (3"), 0400 (4"), 0500 (5") 0600 (6")

Air Cylinder Series NCM



Now available in 8 different bore sizes, 7/16" to 2".

5 Actuation options available:

- Double Acting, Single Rod
- Double Acting, Double Rod
- Non-rotating Rod
- Single Acting, Spring Return
- Single Acting, Spring Extend

A wide variety of mounting configurations:

- Front Nose Mount
- Rear Pivot Mount
- Double End Mount
- Block Mount
- Foot Mount (optional brackets)

Chrome plated carbon steel piston rod improves corrosion resistance. Stainless steel 304 is available for further protection.

Available bumper for increased kinetic energy absorption, increased life cycles, and decreased noise.

Piston is crimped to rod to achieve tighter clearances and reduce piston rod deflection.

Chromated aluminum piston improves corrosion resistance.

Magnetic actuated limit switches are available as a standard option.

Seal, wear ring, and polished stainless steel tube work together to absorb side load and decrease overall friction, ensuring long lasting service life. (Wear ring used on 3/4" bore and larger.)



Rolled threads for increased strength.

Clear anodized end covers provide long lasting protection against corrosion.

Full port design increases cylinder response.

Pre-lubricated at the factory means that the NCM does not require a lubricated air system.

Series NCM Air Cylinder Model Selection

Step

1 Obtain the bore of the cylinder tube. → Refer to Graph (1) and (2).

① Determine the load factor in accordance with the purpose.

Purpose of operation		Load factor η
Static operation (Clamping, Low-speed vise crimping, etc.)		0.7 or less (70% or less)
Dynamic operation	Horizontal movement of load on guide	1 or less (100% or less)
	Vertical and horizontal movement of the load	0.5 or less ^(Note) (50% or less)

 Note) If it is particularly necessary to operate at high speeds, the load rate must be reduced further. (In the graph, it is possible to select a load rate of 0.4, 0.3, 0.2 or less.)

② Determine the operating pressure.

Generally, set the regulator to 85% of the source air pressure. (In the graph, a selection between 0.2 MPa and 0.8 MPa is possible.)

③ Determine the direction in which the cylinder force will be used.

Extending side → Refer to Graph (1).

Retracting side → Refer to Graph (2).

Note) If the same load is applied both for pushing and pulling in a horizontal operation, set the direction to the pulling side.

Step

2 Take the impact at the stroke end into consideration.

① When an external stopper (shock absorber, etc.) is provided to absorb the impact, select a stopper with sufficient absorption capacity.

② Stopping the piston with the cylinder without a stopper:

Verify in Graph (3) to (4) the absorption capacity of the cushion that is enclosed in the cylinder.

Bumper..... Urethane rubber is used for preventing metal-to-metal contact between the piston and the cover.

Step

3 The aspects indicated below may need to be taken into consideration, depending on how the cylinder is operated.

① If a lateral load is applied to the piston rod:

Verify in Graph (5) whether the lateral load is within an allowable range.

② When using a cylinder with a relatively long stroke, if a buckling force acts on the piston rod or the cylinder tube, verify in the table whether the stroke or the operating pressure is within a safe range.

Step

4 Obtain the cylinder's air consumption and its required air volume.

Obtain the air consumption selecting a compressor and for calculating the running cost and the required (Graph (6) to (7)) that is necessary for selecting a compressor and for calculating the running cost and the required air volume (Graph (8)) that is necessary for selecting equipment such as an air filter or a regulator, or the size of the piping upstream.

Model Selection

Step

1

Obtain the bore of the cylinder tube. → Refer to Graph (1) and (2).

Graph (1)
Extending Side Cylinder Force (Double acting cylinder)

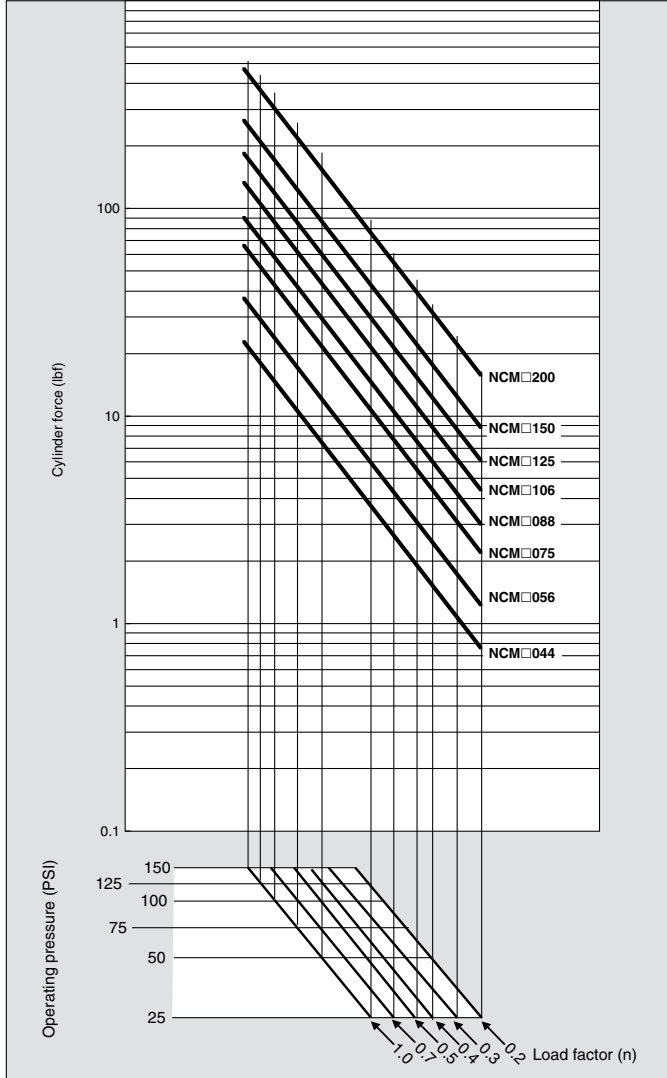

(Example)

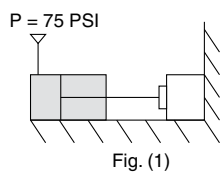

Example 1: If the minimum force of 85 lbf is necessary to keep the workpiece pressed as shown in Fig. (1), because this is the extending side, use Graph (1) to determine the load factor of 0.7 and the operating pressure of 75 PSI. Then, seek the point at which the cylinder force of 85 lbf intersects, and this will result in a bore size of 1.5 inches.

Graph (2)
Retracting Side Cylinder Force (Double acting cylinder)

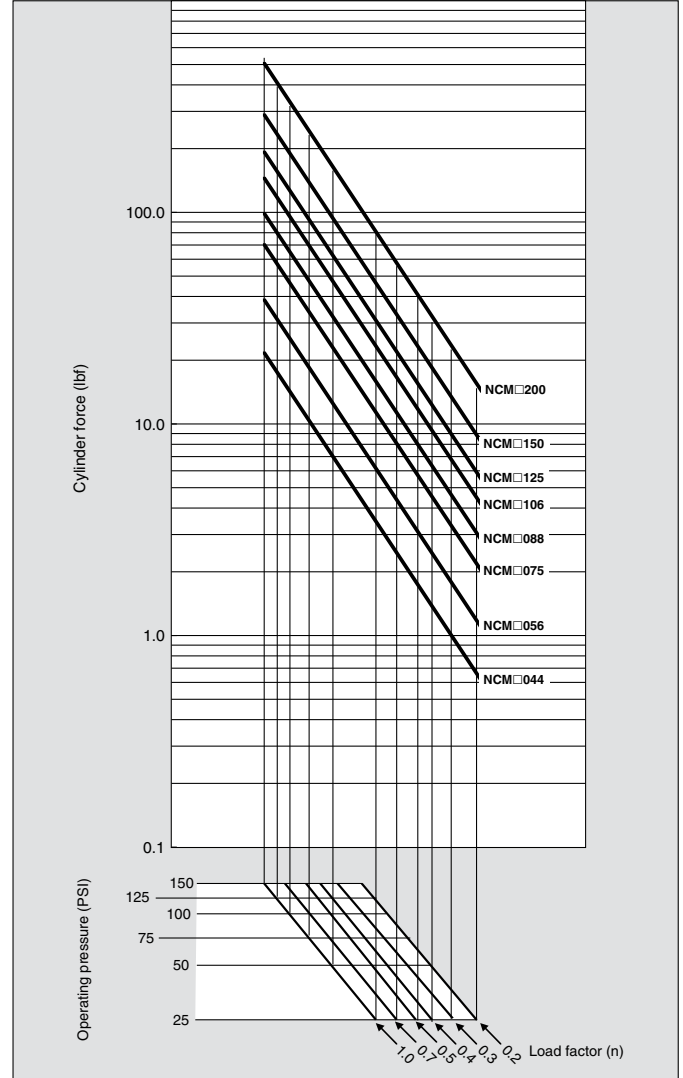

(Example)

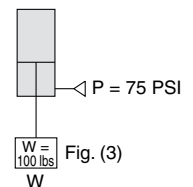
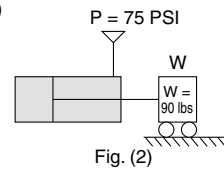

Example 2: To move a load with a 90 lbf weight horizontally on a guide as shown in Fig. (2), because the load is the same for both the pushing and retracting sides, use Graph (2), which is the retracting side with a smaller force. Determine the load factor of 1, and the operating pressure of 75 PSI. Then, seek the point at which it intersects with the load weight of 90 lbs, and this will result in a bore size of 1.5 inches.

Example 3: To pull a load with a 100 lbs weight vertically upward as shown in Fig. (3), use Graph (2) to determine the load factor of 0.5 and the operating pressure of 75 PSI. Then, seek the point at which it intersects with the load weight of 100 lbs, and this will result in a bore size of 2.0 inches.

Step

2

Take the impact at the stroke end into consideration.

With Bumper

Without Bumper



NCM

Graph (3)
Allowable Kinetic Energy with Bumper

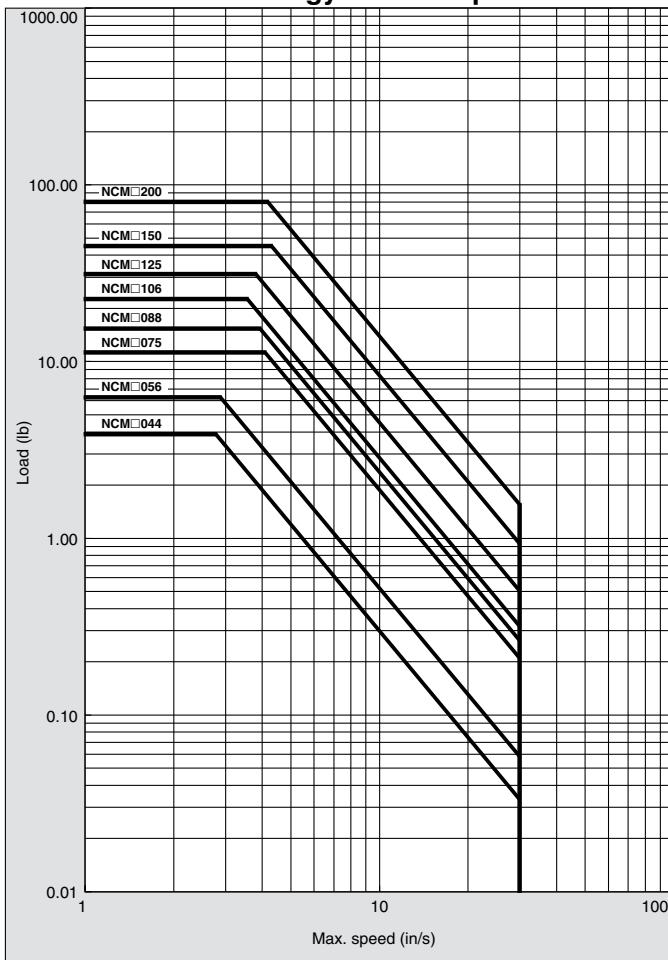

Graph (4)
Allowable Kinetic Energy without Bumper

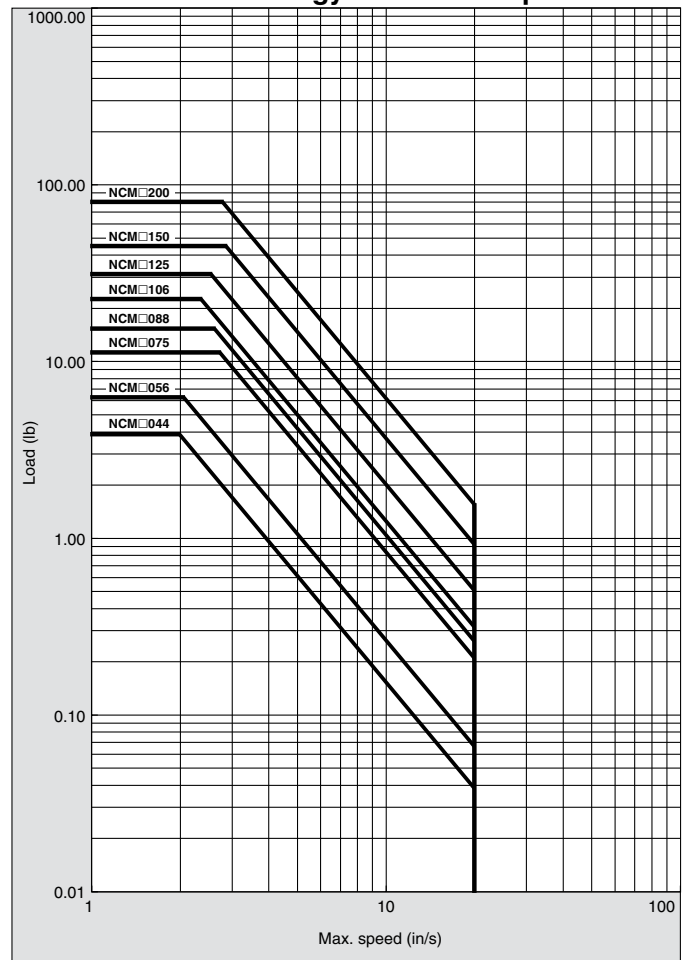

Model Selection

Step

3

The aspects indicated below may need to be taken into consideration, depending on how the cylinder is operated.

- ① The maximum stroke at which the cylinder can be operated under a lateral load.

The region that does not exceed the bold solid line represents the allowable lateral load in relation to the cylinder of a given stroke length. In the graph, the range of the broken line shows that the long stroke limit has been exceeded. In this region, as a rule, operate the cylinder by providing a guide along the direction of movement.

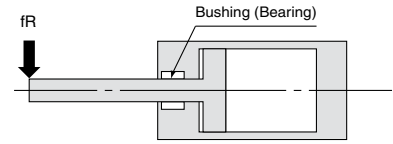

Graph (5)

Max. Allowable Lateral Load

0.44 (7/16"), 0.56 (9/16"), 0.75 (3/4"), 0.88 (7/8"), 1.06 (1-1/16"), 1.25 (1-1/4"), 1.50 (1-1/2"), 2.00 (2") (inch)

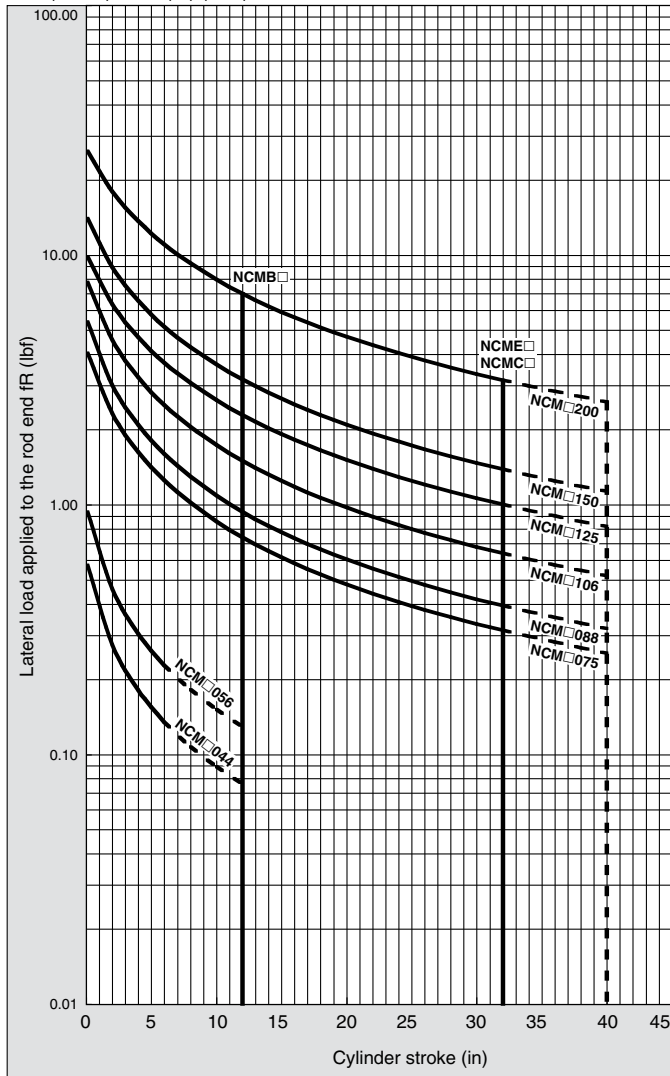

Step

3

The aspects indicated below may need to be taken into consideration, depending on how the cylinder is operated.

Mounting			Type	Operating pressure (PSI)	Maximum stroke that can be used according to buckling strength (inch)										
Mounting Type					NCM										
					044	056	075	088	106	125	150	200			
			1, 2	25	(12)*	11	13.5	11.5	14.5	25	20.5	17			
				50	10	7.5	9	7.5	10	17	14	11			
				75	8	6	7	6	8	13.5	11	8.5			
				100	6.5	5	6	5	6.5	11.5	9.5	7			
				125	6	4.5	5.5	4.5	6	10	8	6			
				150	5	4	4.5	4	5	9	7	5.5			
			3	25	6	4.5	5	4.5	6	10.5	8.5	6.5			
				50	3.5	2.5	3	2.5	3.5	7	5.5	3.5			
				75	2.5	2	2	1.5	2.5	5	4	2.5			
				100	2	1.5	1.5	1	2	4	3	1.5			
				125	1.5	1	1	1	1.5	3.5	2.5	1			
				150	1.5	1	1	0.5	1	3	2	0.5			
			Type 4			4	25	(12)*	10	12	10.5	13.5	24	19.5	15.5
							50	9	6.5	8	6.5	9	16	13	10
							75	7	5	6	5	7	12.5	10	7.5
100	5.5	4					5	4	5.5	10.5	8.5	6			
125	5	3.5					4	3.5	5	9	7	5			
150	4.5	3					3.5	3	4	8	6.5	4.5			
						U									
			T												
			1, 2	25	(12)*	(12)*	(40)*	34	(40)*	(40)*	(40)*	(40)*			
				50	(12)*	(12)*	28	24	31	(40)*	(40)*	36			
				75	(12)*	(12)*	22.5	19	25	(40)*	(40)*	29			
				100	(12)*	(12)*	19.5	16.5	21.5	36	29.5	24.5			
				125	(12)*	(12)*	17	14.5	19	32	26.5	22			
				150	(12)*	(12)*	15.5	13	17	29	24	20			
			3	25	(12)*	(12)*	18.5	15.5	20.5	35	29	24			
				50	(12)*	10.5	12.5	10.5	14	24	20	16			
				75	11	8.5	9.5	8	11	19	15.5	12.5			
				100	9	7	8	7	9	16.5	13	10.5			
				125	8	6	7	6	8	14.5	11.5	9			
				150	7	5.5	6	5	7	13	10.5	8			
						1, 2	25	(12)*	(12)*	(40)*	(40)*	(40)*	(40)*	(40)*	(40)*
							50	(12)*	(12)*	(40)*	34	(40)*	(40)*	(40)*	(40)*
							75	(12)*	(12)*	32.5	27.5	36	(40)*	(40)*	(40)*
							100	(12)*	(12)*	28	24	31	(40)*	(40)*	36
							125	(12)*	(12)*	25	21	27.5	(40)*	38	32
							150	(12)*	(12)*	22.5	19	25	(40)*	34.5	29
3	25	(12)*				(12)*	27	23	30	(40)*	(40)*	35			
	50	(12)*				(12)*	18.5	15.5	20.5	35	29	24			
	75	(12)*				(12)*	14.5	12.5	16.5	28.5	23	19			
	100	(12)*				10.5	12.5	10.5	14	24	20	16			
	125	(12)*				9	11	9	12	21.5	17.5	14			
	150	11				8.5	9.5	8	11	19	15.5	12.5			

* The data in () are limited by max. stroke length.

Note 1) This data is in 0.5 inch increments (round off).

Note 2) For those that exceed maximum stroke that can be manufactured, (40) indicates the maximum stroke that can be manufactured.

- ② The relationship between the cylinder size and the maximum stroke depending on the mounting style.

Assuming that the force that is generated by the cylinder itself acts as a buckling force on the piston rod or on the piston rod and the cylinder tube, the table below indicates in inches the maximum stroke that can be used, which was obtained through calculation. Therefore, it is possible to find the maximum stroke that can be used with each cylinder size according to the relationship between the level of the operating pressure and the type of cylinder mounting, regardless of the load factor.



Reference: Even under a light load, if the piston rod has been stopped by an external stopper at the extending side of the cylinder, the maximum force generated by the cylinder will act upon the cylinder itself.

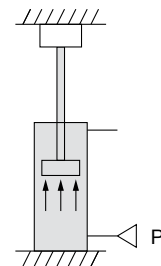

Model Selection

Step

4

Obtain the cylinder's air consumption and its required air volume.

Cylinder's air consumption and its required air volume.

In equipment that uses a cylinder, air consumption is the volume of air that is consumed in the cylinder, or in the piping between the cylinder and the switching valve, every time the switching valve operates.

This is necessary for selecting a compressor and for calculating the running cost. The required air volume is the volume of air that is necessary for operating a specified load at a specified speed, and it is necessary for selecting the F.R.L equipment or the size of the upstream piping.

How to Obtain the Air Consumption/How to Read Graphs (6), (7)

Step 1 By using Graph (6), obtain the air consumption of the air cylinder.

- ① Seek the point at which the operating pressure (diagonal line) intersects with the cylinder stroke, and from that point, perpendicularly extend a vertical line upward.
- ② From the point at which it intersects with the bore size (diagonal line) of the cylinder to be used, look sideways (Either to the right or left) to obtain the air consumption that is required by one cycle of the air cylinder.

Step 2 By using Graph (7), obtain the air consumption of the tube or steel pipe in the same way as in Step 1.

Step 3 Obtain the total air consumption per minute as described below.

(Air consumption of air cylinder + Air consumption of tube or steel pipe) x Number of cycles per minute x Number of cylinders being used = Total air consumption [Unit: ℓ/min (ANR)]



Note) In selecting a compressor, the temperature drop, leakage, and consumption by the intermediary equipment must be taken into consideration. Thus, select one with a generous capacity, with a discharge that exceeds the total air consumption indicated above. (Reference: At a minimum, select one with 1.4 times the volume; select one with a higher volume as needed.)

Example: When 10 air cylinders with a 1.25 inch bore size and a 3 inch stroke are used at a pressure of 50 PSI, what is the air consumption of their 5 cycles per minute? (A 20 inch tube with a 0.179 inch bore is used for piping between the cylinders and the switching valve.)

1. Operating pressure 50 PSI → Cylinder stroke 30 inch → Bore size 1.25 inch → Air consumption ≅ 0.5 ℓ(ANR)
2. Operating pressure 50 PSI → Piping length 20 inch → Bore 0.179 inch → Air consumption ≅ 0.1 ℓ (ANR)
3. Total air consumption = (0.5 + 0.1) x 10 x 5 = 30 ℓ/min (ANR)

How to Obtain the Required Air Volume/How to Read Graph (8)

Step 3 By using Graph (8), obtain the air cylinder's required air volume.

- ① Seek the point at which the operating pressure (diagonal line) intersects with the cylinder stroke, and from that point, perpendicularly extend a vertical line upward.
- ② From the point at which it intersects with the bore size (diagonal line) of the cylinder to be used, look sideways (Either to the right or left) to obtain the air consumption that is required by one cycle of the air cylinder.

Example: What is the required air volume for operating a cylinder with a bore size of 1.25 inch, at pressure of 50 PSI, and at a speed of 10 inch/s?

How to read: Operating pressure 50 PSI → Maximum piston speed 500 mm/s → Bore size 1.25 inch → Then, a required air volume 30 ℓ/min (ANR) can be obtained.

Graph (6) Cylinder's Air Consumption (For one cycle)

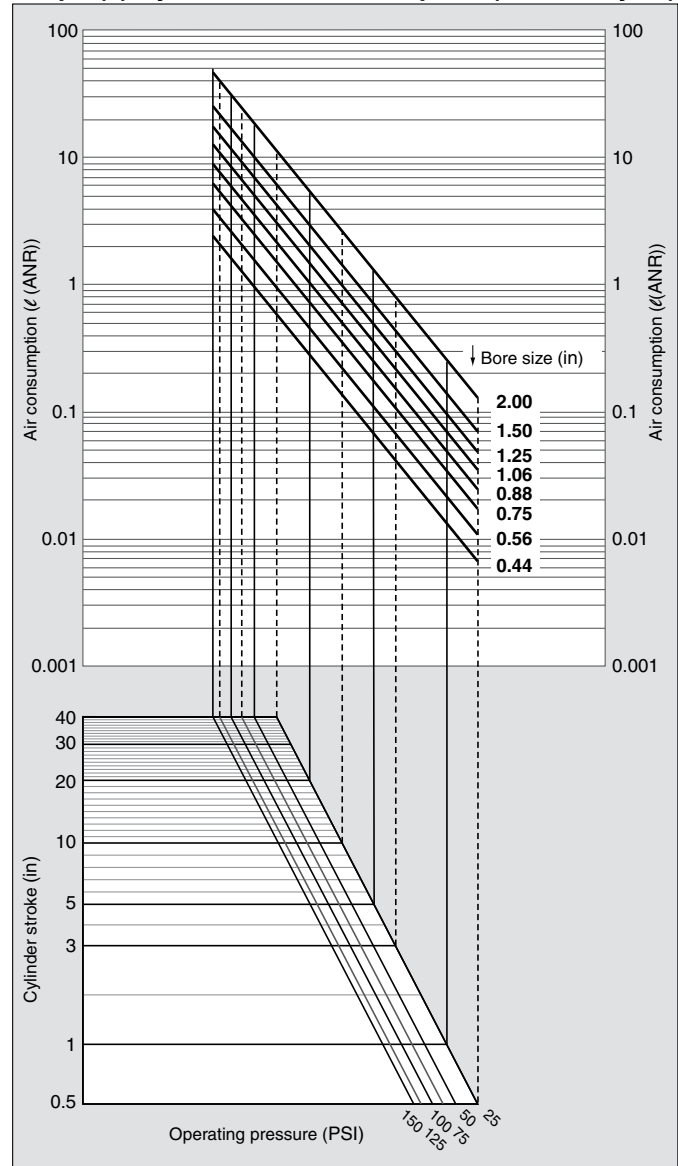

Step

4

Obtain the cylinder's air consumption and its required air volume.

Cylinder's air consumption and its required air volume.

In equipment that used a cylinder, air consumption is the volume of air that is consumed in the cylinder, or in the piping between the cylinder and the switching valve, every time the switching valve operates.

This is necessary for selecting a compressor and for calculating the running cost. The required air volume is the volume of air that is necessary for operating a specified load at a specified speed, and it is necessary for selecting the F.R.L equipment or the size of the upstream piping.

Graph (7)
Air Consumption of Tube or Steel Pipe (For one cycle)

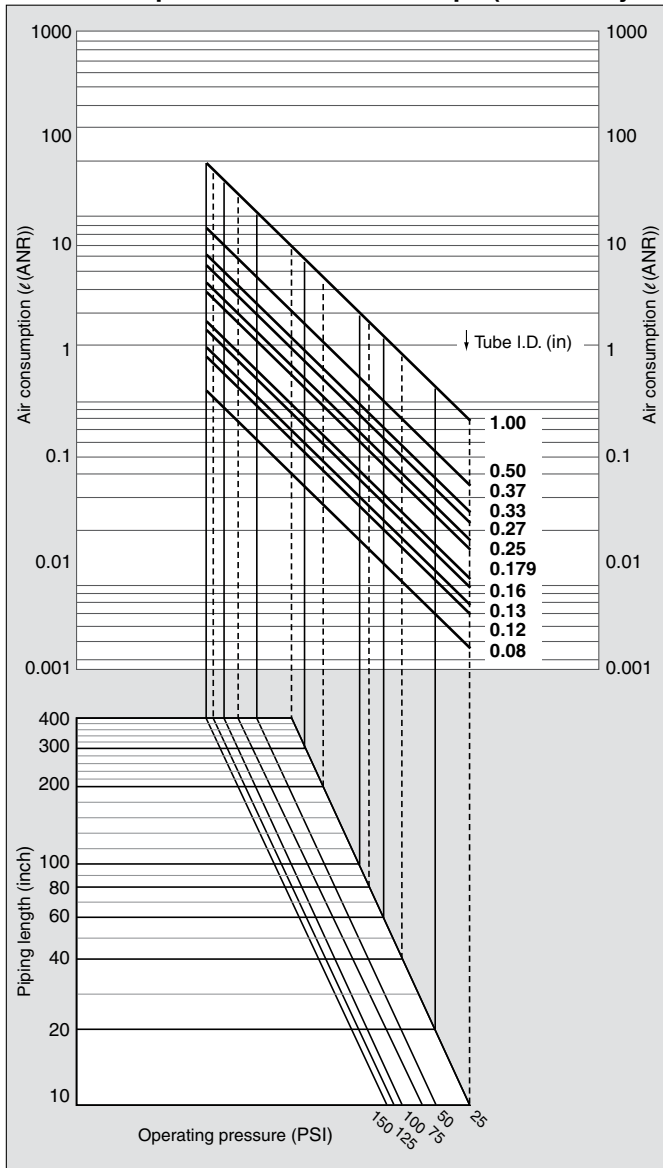

Graph (8)
Required Air Volume of Cylinder and Piping

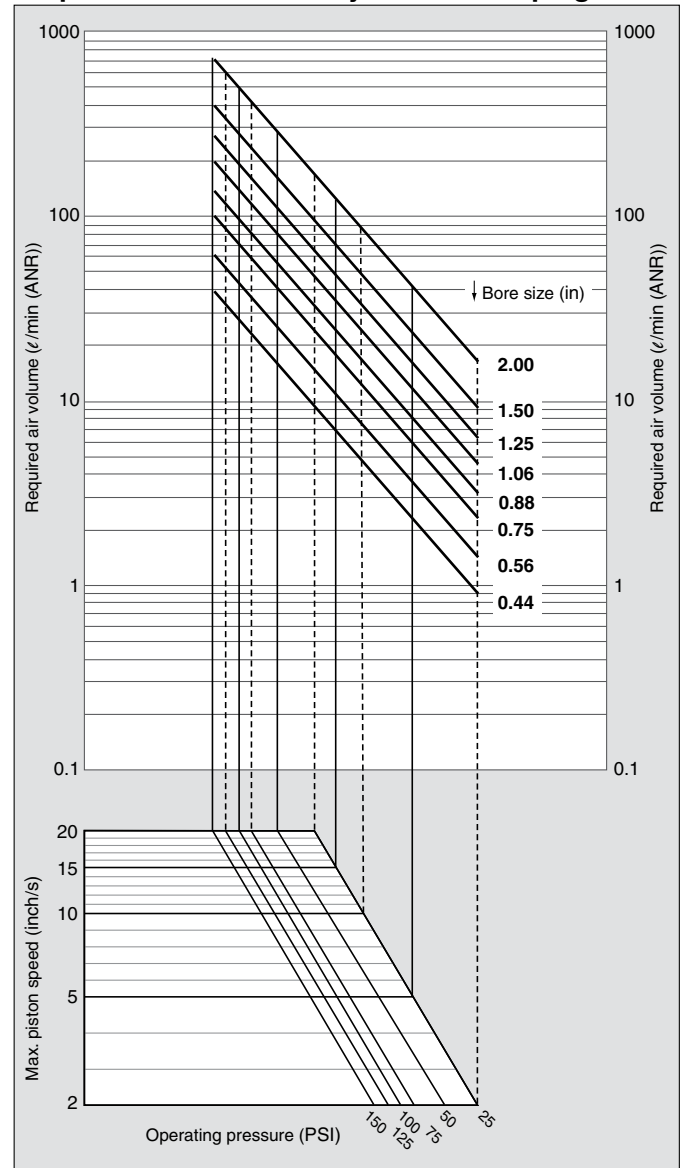

* The piping length is the length of the steel pipe or tube that connects the cylinder with the switching valve (solenoid valve, etc.)
* For the dimensions (bore size and O.D.) of the steel tubing, refer to SMC "Best Pneumatics 2004" Vol. 6 catalog.

Air Cylinder: Standard Double Acting, Single/Double Rod Series *NCM*

How to Order

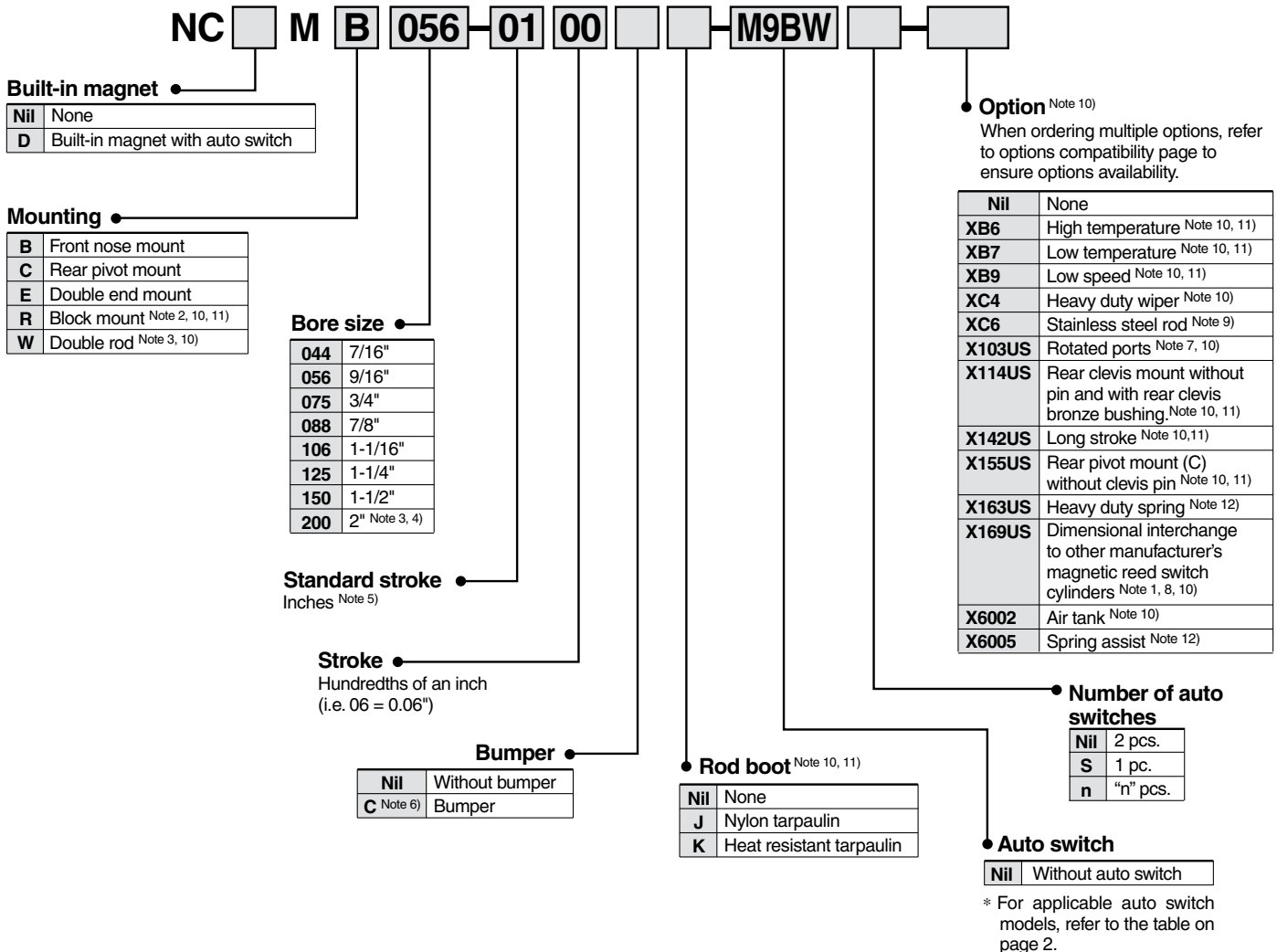

- Note 1) $\phi 3/4"$, $\phi 1-1/16"$, $\phi 1-1/2"$ and $\phi 2"$ only.
 Note 2) Not offered in $\phi 7/8"$, $\phi 1-1/4"$, or with rod boot.
 Note 3) Double acting only.
 Note 4) Not available as standard with C, R mount, with rod boot.
 Note 5) See specifications for standard and maximum stroke lengths.
 Note 6) Bumper is offered at no additional cost on $\phi 7/8"$ and $\phi 1-1/4"$. They are options on the other bore sizes. The "C" after the bore size must be included in either case. Bumper affects cylinder overall length of some models. Refer to the dimensional data.
 Note 7) Available only with B or C mounting. Not available on 2" bore.
 Note 8) Not available with $\phi 7/8"$ bore, or with C, R mount, or non-rotating rod (K).
 Note 9) Stainless steel rod standard on $\phi 7/16"$, $\phi 9/16"$, $\phi 3/4"$ and $\phi 7/8"$.
 Note 10) Exclude $\phi 7/16"$ and $\phi 9/16"$.
 Note 11) Exclude $\phi 2"$.
 Note 12) $\phi 3/4"$, $\phi 1-1/16"$ and $\phi 1-1/2"$ only.

Auto Switch Specifications

Applicable Auto Switches

Type	Special function	Electrical entry	Indicator light	Wiring (Output)	Load voltage		Auto switch model	Lead wire length (m)					Pre-wired connector	Applicable load						
					DC	AC		0.5 (Nil)	1 (M)	3 (L)	5 (Z)	None (N)		IC circuit	Relay, PLC					
Solid state switch	—	Grommet	Yes	3-wire (NPN)	5 V, 12 V	—	M9N	●	●	○	○	○	IC circuit	Relay, PLC						
		3-wire (PNP)		●				●	○	○										
		Connector		2-wire				12 V	●	●	○	○								
	Diagnostic indication (2-color indication)	Grommet	Yes	3-wire (NPN)	24 V	5 V, 12 V	—	M9NW	●	●	○	○	IC circuit							
				3-wire (PNP)					●	●	○	○								
				2-wire					12 V	●	●	○			○					
	Water resistant (2-color indication)	Grommet	Yes	4-wire (NPN)	5 V, 12 V	—	H7NF	●	—	○	○	IC circuit								
	With diagnostic output (2-color indication)							—	—	○	○									
	Reed switch	—	Grommet	Yes	3-wire (NPN equivalent)	—	5 V	—	A96	●	—	●	—		IC circuit	Relay, PLC				
Connector					2-wire					24 V	12 V	100 V	A93	●			—	●	—	IC circuit
												100 V or less	A90	●			—	●	—	
			100 V, 200 V	B54		●	—	●	●			—								
Grommet			2-wire	24 V	12 V	200 V or less	B64	●	—	●	—									
						—	C73C	●	—	●	●									
						24 V or less	C80C	●	—	●	●									
Diagnostic indication (2-color indication)			Grommet	Yes	—	—	—	—	B59W	●	—	●	—	—						

- * Lead wire length symbols: 0.5 m Nil (Example) M9NW
- 1 m M (Example) M9NWM
- 3 m L (Example) M9NWL
- 5 m Z (Example) M9NWZ
- None N (Example) H7CN
- * Solid state switches marked with "○" are produced upon receipt of order.
- * D-B54, B64, and B59W cannot be mounted for bore size 044 and 056.

- * For details about auto switches with pre-wired connector, refer to Best Pneumatics catalog.
- * D-A9□, M9□, M9□W are shipped together.
(Only switch mounting bracket is assembled at the time of shipment.)
- * D-M9□M and M9□VM which lead wire length is 1 m are available from July, 2008.

Series NCM

Option Compatibility

Option Compatibility (1)

	Description	Note	NCM-Standard	NCDM	NCMW	NCM-*J	NCM-*K	C	XB6	XB7	XB9	XC6
NCM	Standard		–	–								
NCDM	Auto switch capable		O	O								
NCMW	Double rod	5	O	O	–							
NCM-*J	Nylon rod boot	1, 5	O	O	S	–						
NCM-*K	Neoprene rod boot	1, 5	O	O	S	N	–					
C	Bumper	2	O	S	O	O	O	–				
XB6	Heat resistant	1, 5	O	S	O	S	S	N	–			
XB7	Cold resistant	1, 5	O	S	O	S	S	N	N	–		
XB9	Low speed	1, 5	O	O	S	S	S	O	N	N	–	
XC6	Stainless steel rod	3	O	O	O	O	O	O	O	O	O	–
B	Front nose mount		O	O	N	O	O	O	O	O	O	O
C	Rear pivot mount	1	O	O	N	O	O	O	O	O	O	O
E	Double end mount		O	O	N	O	O	O	O	O	O	O
R	Block mount	1, 5	O	O	S	N	N	O	S	S	O	O

O Combination available to order

S Available with special request

N Not available

Note 1) Exclude ø2".

Note 2) Bumper no additional charge on ø7/8" and ø1-1/4".

Note 3) Stainless steel rod standard on ø7/16", ø9/16", ø3/4" and ø7/8". Use XC6 option to get stainless steel rod nut.

Note 4) Block mount not available in ø7/8" and ø1-1/4".

Note 5) Exclude ø7/16" and ø9/16".

Option Compatibility (2)

	044	056	075	088	106	125	150	200
Double acting, Single rod, No bumper	O	O	O	O	O	O	O	O
Double acting, Single rod, With bumper	O	O	O	O	O	O	O	O
Double acting, Double rod, No bumper			O	O	O	O	O	
Double acting, Double rod, With bumper			O	O	O	O	O	
With rod boot			O	O	O	O	O	
Direct double acting, Single rod, No bumper			O		O		O	
Direct double acting, Single rod, With bumper			O		O		O	
Direct single acting, Spring return (S), No bumper			O		O		O	
Direct single acting, Spring extend (T), No bumper			O		O		O	
Double acting, Single rod, No bumper XB6			O	O	O	O	O	
Double acting, Single rod, No bumper XB7			O	O	O	O	O	
Double acting, Single rod, No bumper XB9			O	O	O	O	O	
Double acting, Single rod, With bumper XB9			O	O	O	O	O	
Double acting, Single rod, No bumper XC6	Standard	Standard	O	O	O		O	
Double acting, Single rod, With bumper XC6	Standard	Standard	O	O	O	O	O	
Double acting, Single rod, No bumper, With air cushion			O	O	O	O	O	

Specifications: Double Acting, Single/Double Rod

Specifications

Bore size (inch)	044 (7/16")	056 (9/16")	075 (3/4")	088 (7/8")	106 (1-1/16")	125 (1-1/4")	150 (1-1/2")	200 (2")
Fluid	Air							
Maximum operating pressure	250 PSI / 1.7 MPa							
Minimum operating pressure	8 PSI / 0.06 MPa							
Ambient and fluid temperature	40 to 140F / 5 to 60 C							
Piston speed	No bumper: 2 to 20 in/sec (50 to 500 mm/sec) Bumper: 2 to 30 in/sec (50 to 750 mm/sec)							
Bumper	Optional (No additional charge on 7/8" and 1-1/4" bore)							
Lubrication	Not required (Pre-lubricated at factory)							
Mounting	B, C, E, R (see Note)							

Note) R mount available on ø3/4", ø1-1/16", and ø1-1/2" only.

Standard Stroke

(inch)

Mounting	Standard stroke	Max. stroke as standard ^{Note 2)}	Long stroke -X142US ^{Note 3)}
Front nose mount (B)	1/2, 1, 2, 3, 4, 5, 6	12	40
Rear pivot mount (C)	1/2, 1, 2, 3, 4, 5, 6	32	40
Double end mount (E)	1/2, 1, 2, 3, 4, 5, 6	32	
Block mount (R) ^{Note 3)}	1/2, 1, 2, 3, 4, 5, 6	12	40
Double rod (W) ^{Note 3)}	1/2, 1, 2, 3, 4, 5, 6	12	20

Note 1) Minimum stroke for mounting auto switches: 0.6 inch for 2 switches, 0.4 inch for one switch.

Note 2) The production maximum stroke of ø7/16" and ø9/16" are up to 12 inches.

Note 3) Exclude ø7/16" and ø9/16".

Weight (Except Non-rotating Rod)

(lbs)

Bore size (inch)	Base weight by mounting style					Add'l weight per inch stroke		Add'l weight for magnet	Add'l weight for bumper
	B	C	E	R	W	B, C, E, R	W		
044 (7/16")	0.059	0.076	0.076	N/A	N/A	0.019	N/A	0.008	0.002
056 (9/16")	0.080	0.091	0.091	N/A	N/A	0.026	N/A	0.008	0.004
075 (3/4")	0.200	0.200	0.280	0.210	0.300	0.034	0.048	0.008	0.012
088 (7/8")	0.218	0.198	0.288	N/A	0.308	0.037	0.051	0.010	0.012
106 (1-1/16")	0.330	0.320	0.410	0.430	0.400	0.050	0.071	0.012	0.011
125 (1-1/4")	0.531	0.581	0.681	N/A	0.781	0.079	0.121	0.020	0.029
150 (1-1/2")	0.680	0.710	0.820	1.020	0.930	0.087	0.128	0.024	0.020
200 (2")	1.345	N/A	1.493	N/A	1.812	0.151	0.151	0.030	0.065

Theoretical Output: Double Acting Cylinder (Extend)

(lbf)

Bore size (in)	Rod size (in)	Operating direction	Piston area (in ²)	Operating pressure (PSI)					
				25	50	75	100	125	150
044 (7/16")	0.197	OUT	0.152	3.8	7.6	11.4	15.2	19	22.8
		IN	0.122	3.0	6.1	9.1	12.2	15.2	18.2
056 (9/16")	0.197	OUT	0.246	6.2	12.3	18.5	24.6	30.8	36.9
		IN	0.216	5.4	10.8	16.2	21.6	27	32.4
075 (3/4")	0.250	OUT	0.442	11.1	22.1	33.2	44.2	55.3	66.3
		IN	0.393	9.8	19.7	29.5	39.3	49.1	59
088 (7/8")	0.250	OUT	0.601	15	30.1	45.1	60.1	75.1	90.2
		IN	0.552	13.8	27.6	41.4	55.2	69	82.8
106 (1-1/16")	0.312	OUT	0.887	22.2	44.4	66.5	88.7	110.9	133.1
		IN	0.811	20.3	40.6	60.8	81.1	101.4	121.7
125 (1-1/4")	0.437	OUT	1.227	30.7	61.4	92	122.7	153.4	184.1
		IN	1.077	26.9	53.9	80.8	107.7	134.6	161.6
150 (1-1/2")	0.437	OUT	1.767	44.2	88.4	132.5	176.7	220.9	265.1
		IN	1.617	40.4	80.9	121.3	161.7	202.1	242.6
200 (2")	0.625	OUT	3.14	78.5	157	235.6	314	392.5	471
		IN	2.83	70.8	141.5	212.3	283	353.8	424.5

Series NCM

Construction: Double Acting, Single Rod

NCM044/056

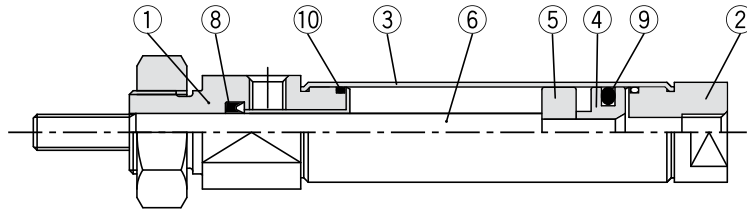

NCMB044 shown as example

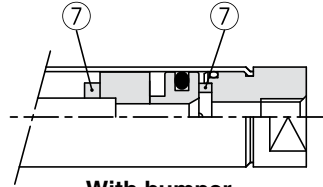

With bumper

Component Parts

No.	Description	Material	Note
1	Rod cover	Aluminum alloy	Anodized
2	Head cover	Aluminum alloy	Anodized
3	Cylinder tube	Stainless steel	
4	Piston A	Aluminum alloy	Chromated
5	Piston B	Aluminum alloy	Chromated
6	Piston rod	7/16", 9/16"	Stainless steel
7	Bumper	Urethane	
8	Rod seal	NBR	
9	Piston seal	NBR	
10	Tube gasket	NBR	

NCM075 and above

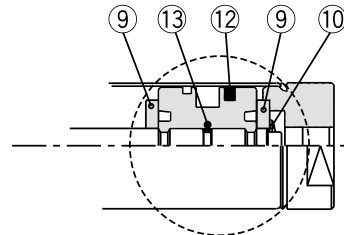
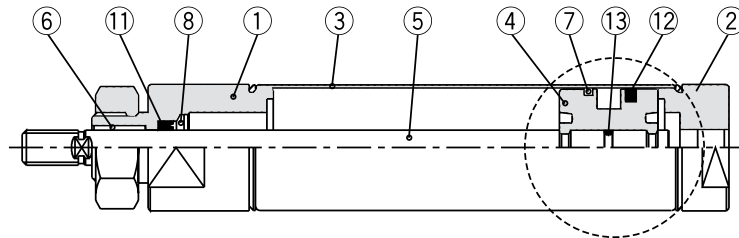

With bumper

Component Parts

No.	Description	Material	Note
1	Rod cover	Aluminum alloy	Anodized
2	Head cover	Aluminum alloy	Anodized
3	Cylinder tube	Stainless steel	
4	Piston	Aluminum alloy	Chromated
5	Piston rod	3/4", 7/8"	Stainless steel
		1-1/16", 1-1/4", 1-1/2", 2"	Carbon steel
6	Bushing	Sintered bronze	
7	Wear ring	Phenolic resin	
8	Retaining ring	Spring steel	
9	Bumper	Urethane	
10	Retaining ring	Spring steel	
11	Rod seal	NBR	
12	Piston seal	NBR	
13	Piston gasket	NBR	

Construction: Double Acting, Double Rod

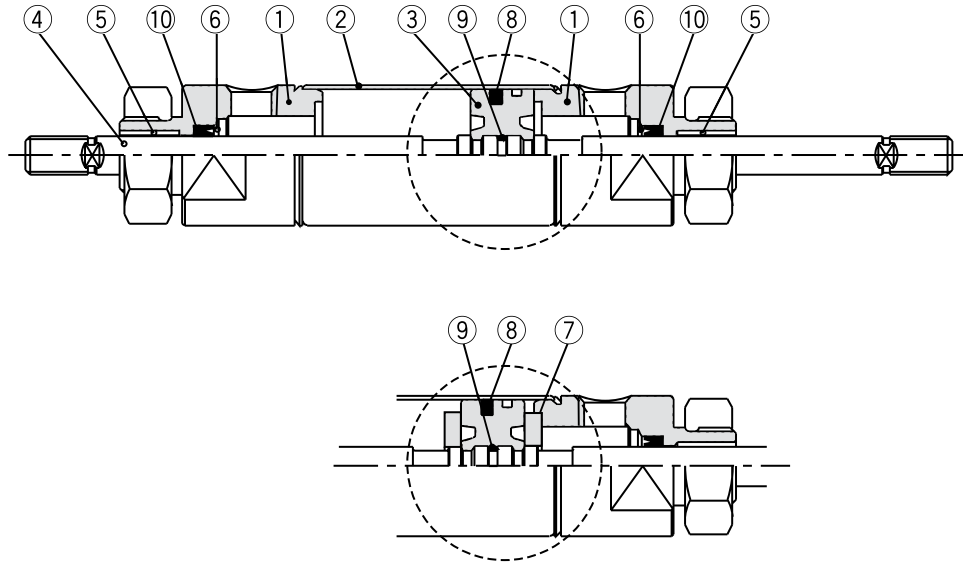

Component Parts

No.	Description	Material	Note
1	Rod cover	Aluminum alloy	Clear anodized
2	Cylinder tube	Stainless steel	Stainless steel 304
3	Piston	Aluminum alloy	Chromated
4	Piston rod	3/4", 7/8"	Stainless steel
		1-1/16", 1-1/4", 1-1/2", 2"	Carbon steel
5	Bushing	Sintered bronze	
6	Retaining ring	Spring steel	
7	Bumper	Urethane	
8	Piston seal	NBR	
9	Piston gasket	NBR	
10	Rod seal	NBR	

Series NCM

Dimensions: Double Acting, Single Rod

Front nose mount: NC(D)MB

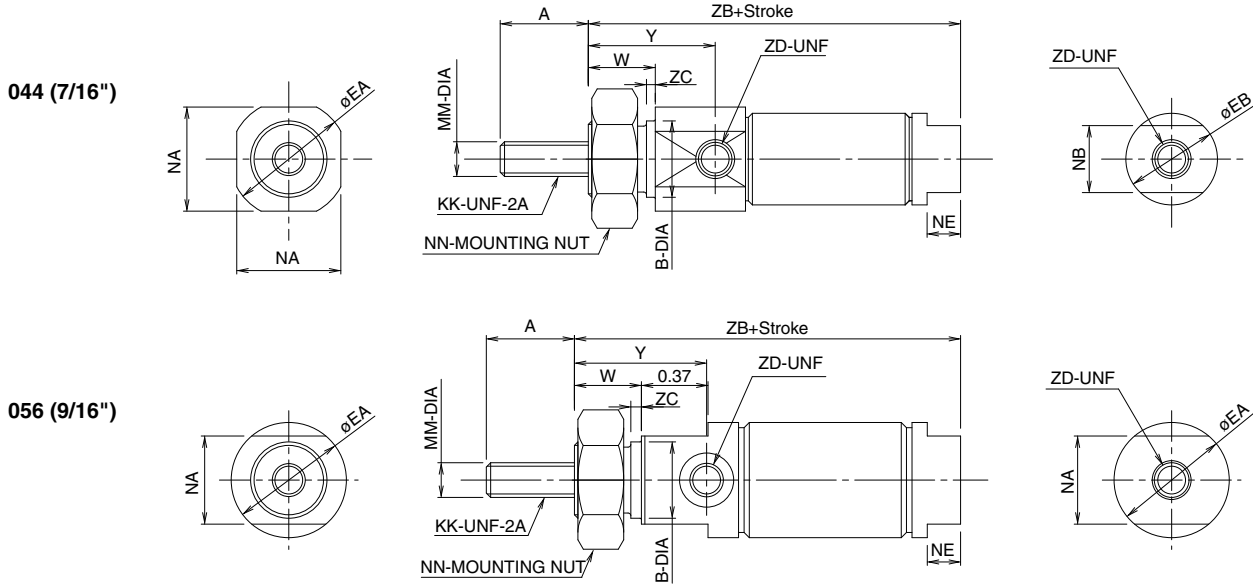

(inch)

Bore size (inch)	A	B	EA	EB	KK	MM	NA	NB	NE	NN	W	Y	ZC	ZD	ZB No bumper, No magnet	ZB With bumper, No magnet	ZB No bumper, With magnet	ZB With bumper, With magnet
044 (7/16")	0.50	0.437 ⁰ _{-0.004}	0.669	0.520	No.10-32	0.197	0.59	0.38	0.19	7/16-20	0.38	0.72	0.05	No.10-32	2.11	2.30	2.36	2.55
056 (9/16")	0.50	0.437 ⁰ _{-0.004}	0.654	-	No.10-32	0.197	0.50	-	0.19	7/16-20	0.38	0.75	0.06	No.10-32	2.19	2.32	2.19	2.32

075 (3/4"), 088 (7/8"), 106 (1-1/16"), 125 (1-1/4"), 150 (1-1/2"), 200 (2")

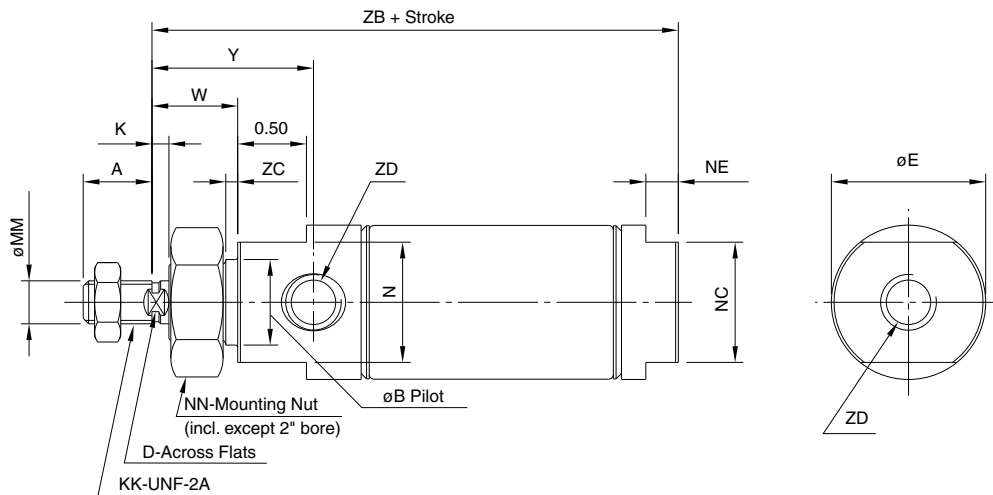

(inch)

Bore size (inch)	MM	KK	A	B	D	E	K	N	NC	NE	NN	W	Y	ZC	ZD	ZB No bumper	ZB With bumper
075 (3/4")	0.250	1/4-28	0.50	0.624 ⁰ _{-0.003}	-	0.86	-	0.75	0.62	0.12	5/8-18	0.50	0.95	0.09	1/8 NPT	2.97	2.97
088 (7/8")	0.250	1/4-28	0.50	0.624 ⁰ _{-0.003}	-	0.93	-	0.75	0.75	0.18	5/8-18	0.50	0.95	0.09	1/8 NPT	2.69	2.94
106 (1-1/16")	0.312	5/16-24	0.50	0.624 ⁰ _{-0.003}	0.25	1.12	0.12	0.88	0.88	0.24	5/8-18	0.62	1.17	0.09	1/8 NPT	3.25	3.38
125 (1-1/4")	0.437	7/16-20	0.75	0.749 ⁰ _{-0.003}	0.38	1.32	0.25	1.06	1.06	0.25	3/4-16	0.88	1.62	0.09	1/8 NPT	3.75	4.00
150 (1-1/2")	0.437	7/16-20	0.75	0.749 ⁰ _{-0.003}	0.38	1.56	0.25	1.25	1.25	0.25	3/4-16	0.88	1.50	0.09	1/8 NPT	3.69	3.82
200 (2")	0.625	1/2-20	0.75	1.375 ⁰ _{-0.003}	0.50	2.06	0.38	1.75	1.75	0.31	1-1/4-12	1.31	2.03	0.12	1/4 NPT	4.69	4.95

Dimensions: Double Acting, Single Rod

Rear pivot mount: NC(D)MC

044 (7/16")

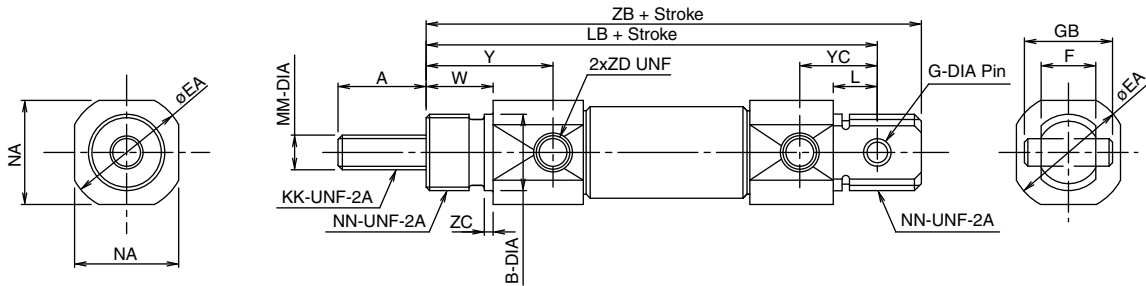

056 (9/16")

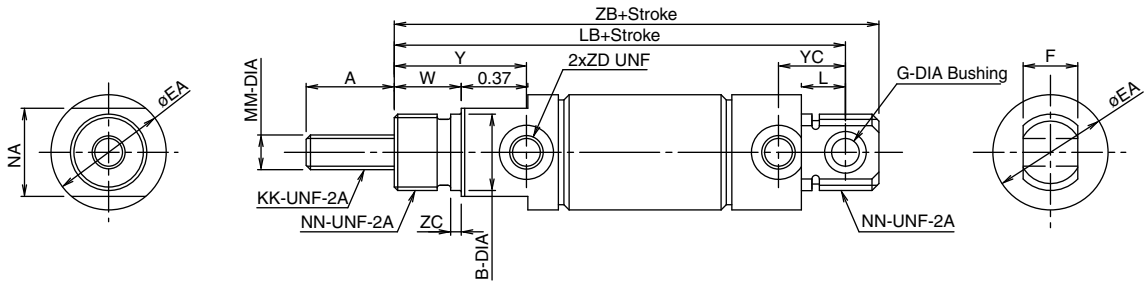

Bore size (inch)	A	B	EA	F	G	GB	KK	L	MM	NA	NN	W	Y	YC	ZC	ZD	LB No bumper, No magnet	LB With bumper, No magnet	LB No bumper, With magnet	LB With bumper, With magnet	ZB No bumper, No magnet	ZB With bumper, No magnet	ZB No bumper, With magnet	ZB With bumper, With magnet
	044 (7/16")	0.50	0.437 ⁰ _{-0.004}	0.669	0.31	0.156	0.50	No.10-32	0.25	0.197	0.59	7/16-20	0.38	0.72	0.44	0.05	No.10-32	2.56	2.75	2.81	3.00	2.81	3.00	3.06
056 (9/16")	0.50	0.437 ⁰ _{-0.004}	0.654	0.31	0.157	—	No.10-32	0.25	0.197	0.50	7/16-20	0.38	0.75	0.38	0.06	No.10-32	2.56	2.69	2.56	2.69	2.75	2.88	2.75	2.88

075 (3/4"), 088 (7/8"), 106 (1-1/16"), 125 (1-1/4"), 150 (1-1/2")

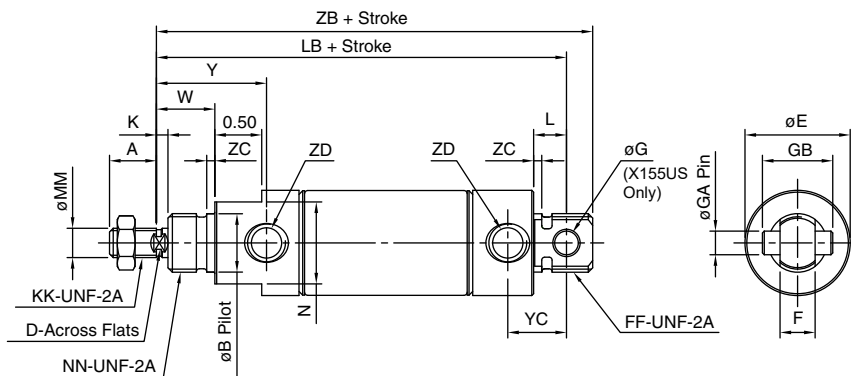

X155US (without clevis pin)	
Bore size (inch)	øG
075 (3/4")	.251
088 (7/8")	.251
106 (1-1/16")	.251
125 (1-1/4")	.251
150 (1-1/2")	.378

Bore size (inch)	MM	KK	A	B	D	E	F	FF	GA	GB	K	L	N	NN	W	Y	YC	LB		ZB	
																		No bumper	With bumper	No bumper	With bumper
075 (3/4")	0.250	1/4-28	0.50	0.624 ⁰ _{-0.003}	—	0.86	0.38	5/8-18	0.250	0.75	—	0.34	0.75	5/8-18	0.50	0.95	0.62	3.75	4.03	3.75	4.03
088 (7/8")	0.250	1/4-28	0.50	0.624 ⁰ _{-0.003}	—	0.93	0.38	5/8-18	0.250	0.75	—	0.34	0.75	5/8-18	0.50	0.95	0.62	3.31	3.59	3.56	3.84
106 (1-1/16")	0.312	5/16-24	0.50	0.624 ⁰ _{-0.003}	0.25	1.12	0.38	5/8-18	0.250	0.75	0.12	0.34	0.88	5/8-18	0.62	1.17	0.62	3.84	4.12	3.97	4.25
125 (1-1/4")	0.437	7/16-20	0.75	0.749 ⁰ _{-0.003}	0.38	1.32	0.50	3/4-16	0.250	0.75	0.25	0.41	1.06	3/4-16	0.88	1.62	0.78	4.47	4.87	4.72	5.12
150 (1-1/2")	0.437	7/16-20	0.75	0.749 ⁰ _{-0.003}	0.38	1.56	0.62	—	0.375	1.00	0.25	0.50	1.25	3/4-16	0.88	1.50	0.78	4.38	4.75	4.51	4.88

Note) There are no threads on the NCMC 150 rear tang (FF dim).

Series NCM

Dimensions: Double Acting, Single Rod

Double end mount: NC(D)ME

044 (7/16")

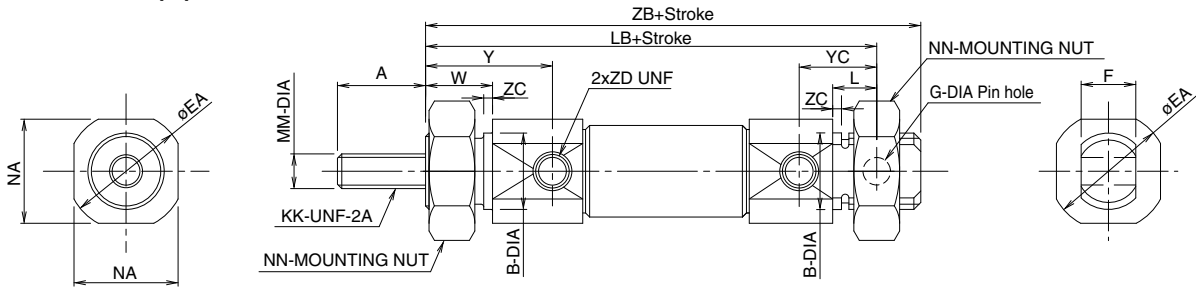

056 (9/16")

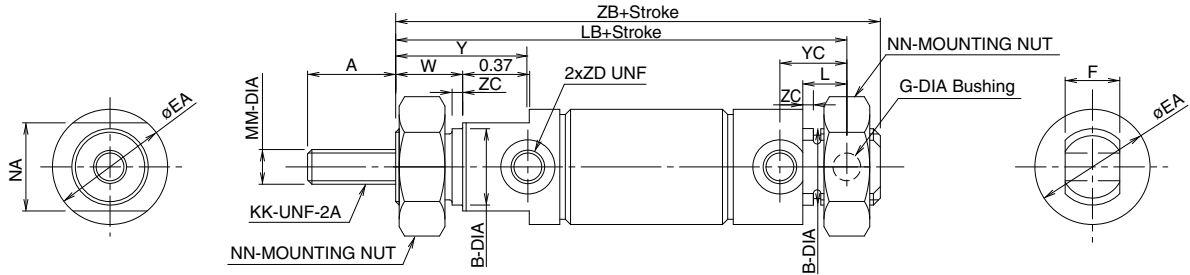

Bore size (inch)	A	B	EA	F	G	KK	L	MM	NA	NN	W	Y	YC	ZC	ZD	(inch)							
																LB No bumper, No magnet	LB With bumper, No magnet	LB No bumper, With magnet	LB With bumper, With magnet	ZB No bumper, No magnet	ZB With bumper, No magnet	ZB No bumper, With magnet	ZB With bumper, With magnet
044 (7/16")	0.50	0.437 ⁰ _{-0.004}	0.669	0.31	0.156	No.10-32	0.25	0.197	0.59	7/16-20	0.38	0.72	0.44	0.05	No.10-32	2.56	2.75	2.81	3.00	2.81	3.00	3.06	3.24
056 (9/16")	0.50	0.437 ⁰ _{-0.004}	0.654	0.31	0.157	No.10-32	0.25	0.197	0.50	7/16-20	0.38	0.75	0.38	0.06	No.10-32	2.56	2.69	2.56	2.69	2.75	2.88	2.75	2.88

075 (3/4"), 088 (7/8"), 106 (1-1/16"), 125 (1-1/4"), 150 (1-1/2"), 200 (2")

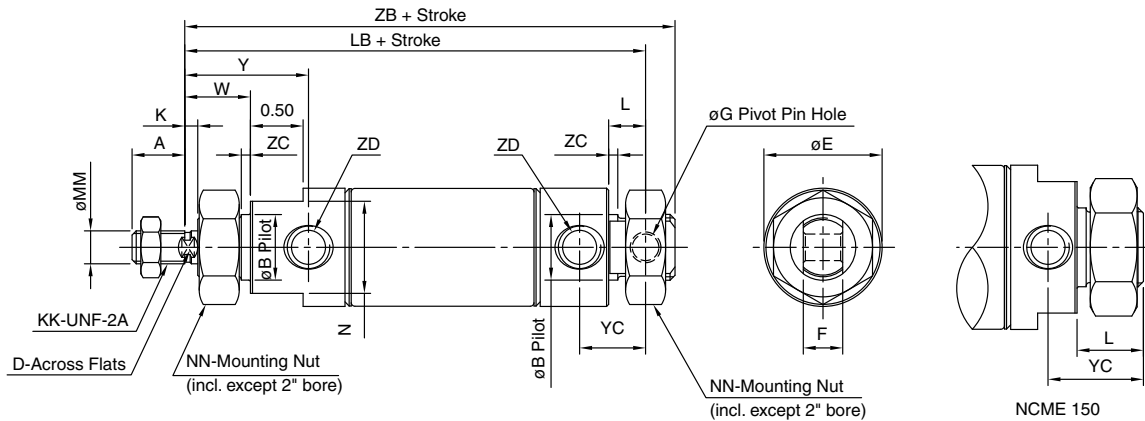

Bore size (inch)	No bumper		With bumper	
	LB	ZB	LB	ZB
075 (3/4")	3.75	4.03	3.75	4.03
088 (7/8")	3.31	3.59	3.56	3.84
106 (1-1/16")	3.84	4.12	3.97	4.25
125 (1-1/4")	4.47	4.87	4.72	5.12
150 (1-1/2")	-	4.5	-	4.63
200 (2")	5.62	6.06	5.88	6.32

Bore size (inch)	MM	KK	A	B	D	E	F	G	K	L	N	NN	W	Y	YC	ZC	ZD	(inch)
075 (3/4")	0.250	1/4-28	0.50	0.624 ⁰ _{-0.003}	-	0.86	0.38	0.251	-	0.34	0.75	5/8-18	0.50	0.95	0.62	0.09	1/8 NPT	
088 (7/8")	0.250	1/4-28	0.50	0.624 ⁰ _{-0.003}	-	0.93	0.38	0.251	-	0.34	0.75	5/8-18	0.50	0.95	0.62	0.09	1/8 NPT	
106 (1-1/16")	0.312	5/16-24	0.50	0.624 ⁰ _{-0.003}	0.25	1.12	0.38	0.251	0.12	0.34	0.88	5/8-18	0.62	1.17	0.62	0.09	1/8 NPT	
125 (1-1/4")	0.437	7/16-20	0.75	0.749 ⁰ _{-0.003}	0.38	1.32	0.50	0.251	0.25	0.41	1.06	3/4-16	0.88	1.62	0.78	0.09	1/8 NPT	
150 (1-1/2")	0.437	7/16-20	0.75	0.749 ⁰ _{-0.003}	0.38	1.56	-	-	0.25	0.63	1.25	3/4-16	0.88	1.50	0.91	0.09	1/8 NPT	
200 (2")	0.625	1/2-20	0.75	1.375 ⁰ _{-0.003}	0.50	2.06	0.75	0.375	0.38	0.56	1.75	1-1/4-12	1.19	1.91	1.03	0.12	1/4 NPT	

Dimensions: Double Acting, Single Rod

Block mount: NC(D)MR

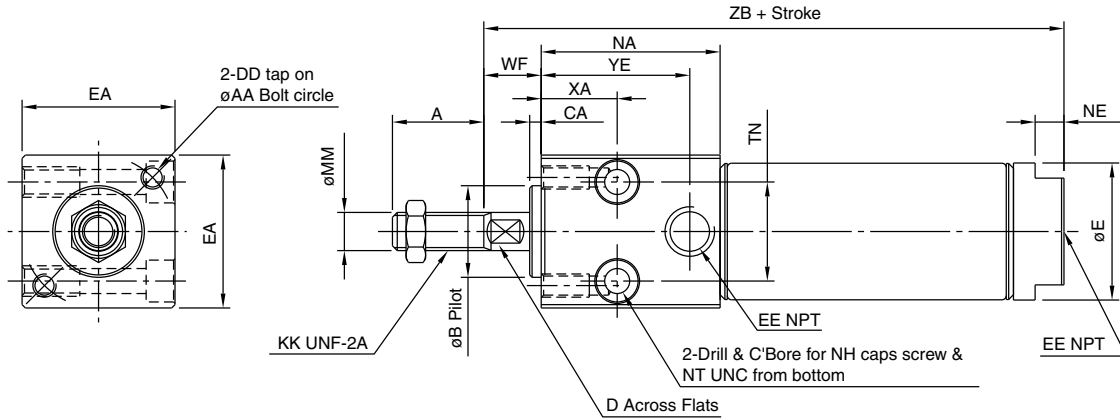

(inch)

Bore size (inch)	MM	KK	A	AA	B	CA	D	DD	E	EA	EE	NA	NE	NH	NT	TN	WF	YE	XA
075 (3/4")	0.250	1/4-28	0.75	1.00	0.625 ⁰ _{-0.002}	0.093	0.22	10-32 UNF	0.81	1.00	1/8	1.12	0.12	10-32 UNF	1/4-20	0.62	0.34	0.88	0.38
106 (1-1/16")	0.312	5/16-24	0.75	1.25	0.750 ⁰ _{-0.002}	0.093	0.25	10-32 UNF	1.12	1.25	1/8	1.47	0.24	10-32 UNF	1/4-20	0.81	0.47	1.22	0.62
150 (1-1/2")	0.437	7/16-20	1.25	1.75	1.00 ⁰ _{-0.002}	0.125	0.38	1/4-20 UNC	1.56	1.75	1/4	1.93	0.25	1/4-20 UNC	5/16-18	1.12	0.38	1.57	0.88

Block Mount

Bore size (inch)	ZB	
	No bumper	With bumper
075 (3/4")	3.22	3.22
106 (1-1/16")	3.75	3.88
150 (1-1/2")	4.19	4.32

Note) Length not affected by addition of magnet.

Series NCM

Dimensions: Double Acting, Double Rod

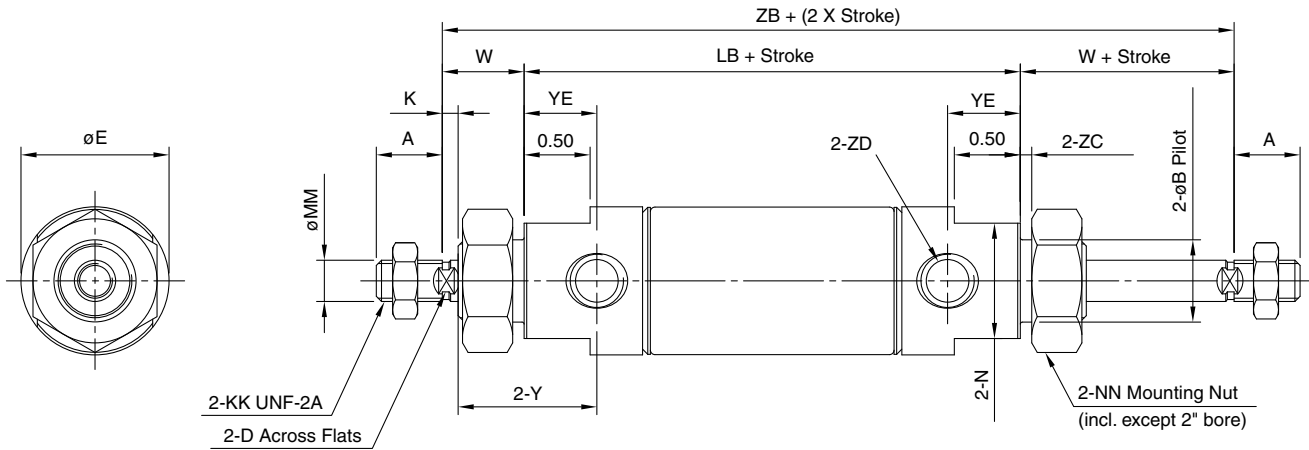

(inch)

Bore size (inch)	MM	KK	A	B	D	E	K	N	NN	W	Y	YE	ZC	ZD
075 (3/4")	0.250	1/4-28	0.50	0.624 ⁰ _{-0.003}	—	0.86	—	0.75	5/8-18	0.50	0.95	0.45	0.09	1/8 NPT
088 (7/8")	0.250	1/4-28	0.50	0.624 ⁰ _{-0.003}	—	0.93	—	0.75	5/8-18	0.50	0.95	0.45	0.09	1/8 NPT
106 (1-1/16")	0.312	5/16-24	0.50	0.624 ⁰ _{-0.003}	0.25	1.12	0.12	0.88	5/8-18	0.62	1.17	0.55	0.09	1/8 NPT
125 (1-1/4")	0.437	7/16-20	0.75	0.749 ⁰ _{-0.003}	0.38	1.32	0.25	1.06	3/4-16	0.88	1.62	0.74	0.09	1/8 NPT
150 (1-1/2")	0.437	7/16-20	0.75	0.749 ⁰ _{-0.003}	0.38	1.56	0.25	1.25	3/4-16	0.88	1.50	0.62	0.09	1/8 NPT
200 (2")	0.625	1/2-20	0.88	1.375 ⁰ _{-0.003}	0.50	2.06	0.38	1.75	1-1/4-12	1.19	1.91	0.72	0.12	1/4 NPT

Double Acting, Double Rod

Bore size (inch)	LB		ZB	
	No bumper	With bumper	No bumper	With bumper
075 (3/4")	3.00	3.00	4.00	4.00
088 (7/8")	2.66	2.91	3.66	3.91
106 (1-1/16")	2.75	2.88	4.00	4.13
125 (1-1/4")	3.56	3.81	5.31	5.56
150 (1-1/2")	3.38	3.51	5.12	5.25
200 (2")	4.18	4.44	6.56	6.82

Note) Length not affected by addition of magnet except 106 bore.

Double Acting, Double Rod with Magnet (106 Bore)

Bore size (inch)	LB		ZB	
	No bumper	With bumper	No bumper	With bumper
106 (1-1/16")	3.13	3.25	4.38	4.50

Air Cylinder: Non-rotating Rod Double Acting, Single Rod

Series *NCM*

How to Order

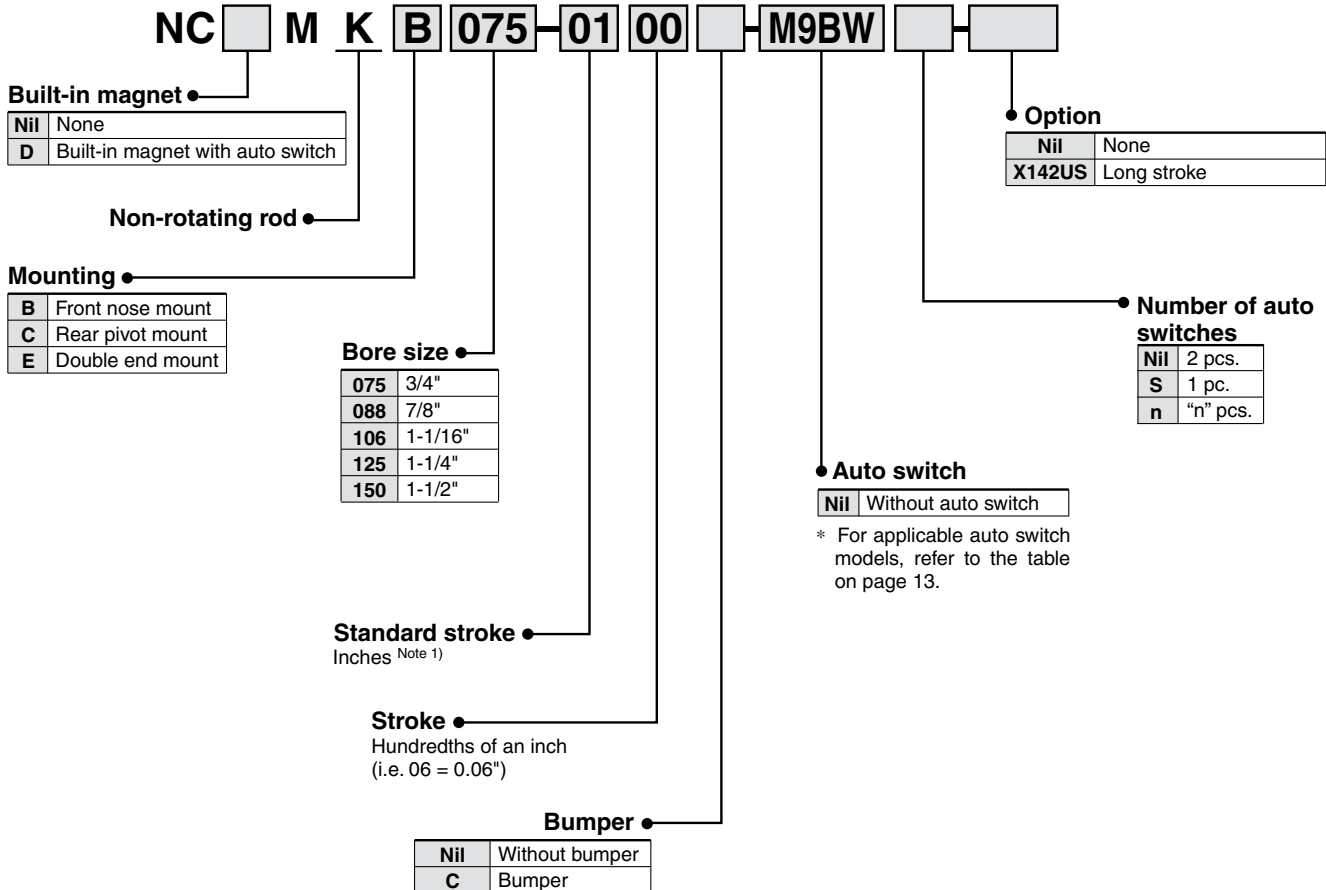

Note 1) See specifications for standard and maximum stroke lengths.

Auto Switch Specifications

Applicable Auto Switches

Type	Special function	Electrical entry	Indicator light	Wiring (Output)	Load voltage		Auto switch model	Lead wire length (m)					Pre-wired connector	Applicable load					
					DC	AC		0.5 (Nil)	1 (M)	3 (L)	5 (Z)	None (N)		IC circuit	Relay, PLC				
Solid state switch	—	Grommet	Yes	3-wire (NPN)	5 V, 12 V	—	—	M9N	●	●	●	○	—			○	IC circuit	Relay, PLC	
				3-wire (PNP)				M9P	●	●	●	○	—	○					
		Connector	2-wire	12 V	M9B	●	●	●	○	—	○	—							
				H7C	●	—	●	●	●	—	—								
	Diagnostic indication (2-color indication)	Grommet	Yes	3-wire (NPN)	24 V	5 V, 12 V	—	—	M9NW	●	●	●	○	—	○	IC circuit			
				3-wire (PNP)					M9PW	●	●	●	○	—	○				
				2-wire					M9BW	●	●	●	○	—	○	—			
				H7BA					—	—	●	○	—	○	—				
Water resistant (2-color indication)	Grommet	Yes	4-wire (NPN)	5 V, 12 V	—	—	—	H7NF	●	—	●	○	—	○	IC circuit				
With diagnostic output (2-color indication)			—					—	—	—	—	—	—						
Reed switch	—	Grommet	Yes	3-wire (NPN equivalent)	24 V	12 V	—	—	A96	●	—	●	—	—	—	IC circuit			
				Connector					2-wire	100 V	A93	●	—	●	—	—	—	—	—
										100 V or less	A90	●	—	●	—	—	—	—	IC circuit
										100 V, 200 V	B54	●	—	●	●	—	—	—	—
										200 V or less	B64	●	—	●	—	—	—		
		—	C73C	●	—	●	●	●	—	—									
		24 V or less	C80C	●	—	●	●	●	—	—									
		Grommet	Yes	2-wire	—	—	—	—	—	B59W	●	—	●	—	—	—	—		

* Lead wire length symbols: 0.5 m Nil (Example) M9NW
 1 m M (Example) M9NWM
 3 m L (Example) M9NWL
 5 m Z (Example) M9NWZ
 None N (Example) H7CN

* Solid state switches marked with "○" are produced upon receipt of order.
 * D-B54, B64, and B59W cannot be mounted for bore size 044 and 056.

* For details about auto switches with pre-wired connector, refer to Best Pneumatics catalog.
 * D-A9□, M9□, M9□W are shipped together.
 (Only switch mounting bracket is assembled at the time of shipment.)
 * D-M9□M and M9□VM which lead wire length is 1 m are available from July, 2008.

Option Compatibility

Option Compatibility (1)

	Description	Note	NCDMK	NCMK
NCDMK	Auto switch capable		—	
NCMK	Non-rotating	1, 7	○	—
NCM-*J	Nylon rod boot	1, 7	S	S
NCM-*K	Neoprene rod boot	1, 7	S	S
C	Bumper	2	○	○
XB6	Heat resistant	1, 7	N	N
XB7	Cold resistant	1, 7	N	N
XB9	Low speed	1, 7	N	N
XC6	Stainless steel rod	3, 4	○	○
B	Front nose mount		○	○
C	Rear pivot mount	1	○	○
E	Double end mount		○	○
R	Block mount	1, 5, 6, 7	S	S

○ Combination available to order
 S Available with special request
 N Not available

Note 1) Exclude ø2".

Note 2) Bumper no additional charge on ø7/8" and ø1-1/4".

Note 3) Stainless steel rod standard on ø7/16", ø9/16", ø3/4" and ø7/8". Use XC6 option to get stainless steel rod nut.

Note 4) Non-rotating rod is stainless steel. Use XC6 option to get stainless steel rod nut.

Note 5) Block mount not available in ø7/8" and ø1-1/4".

Note 6) Block, Auto switch capable, S and T only available as special.

Note 7) Exclude ø7/16" and ø9/16".

Option Compatibility (2)

	044	056	075	088	106	125	150	200
Double acting, Single rod, No bumper, Non-rotating rod			○	○	○	○	○	○
Double acting, Single rod, With bumper, Non-rotating rod			○	○	○	○	○	○

Series NCM

Specifications: Double Acting, Single Rod Non-rotating Rod

Specifications

Bore size (inch)	075 (3/4")	088 (7/8")	106 (1-1/16")	125 (1-1/4")	150 (1-1/2")
Fluid	Air				
Maximum operating pressure	250 PSI / 1.7 MPa				
Minimum operating pressure	8 PSI / 0.06 MPa				
Ambient and fluid temperature	40 to 140°F / 5 to 60 °C				
Piston speed	2 to 20 in/sec / 50 to 500 mm/sec				
Rod material	Stainless steel 303				
Bumper	Optional (No additional charge on 7/8" and 1-1/4" bore)				
Non-rotating accuracy	± 2.0°		± 1.4°		
Maximum allowable torque	0.04 ft-Lbf (0.06 N·m)	0.09 ft-Lbf (0.13 N·m)	0.12 ft-Lbf (0.16 N·m)		

Standard Stroke

(inch)

Mounting	Standard stroke	Max. stroke as standard	Long stroke -X142US
Front nose mount (B)	1/2, 1, 2, 3, 4, 5, 6,	12	40
Double end mount (E) Rear pivot mount (C)	1/2, 1, 2, 3, 4, 5, 6, 7, 8, 10, 12	32	40

Note 1) Minimum stroke for mounting auto switches: 0.6 inch for 2 switches, 0.4 inch for one switch.

Note 2) Spring return up to 18" available as special request.

Theoretical Output: Non-rotating Rod

(lbf)

Bore size (inch)	Rod diameter (inch)	Operating direction	Effective area (sq.inch)	Operating pressure (PSI)					
				25	50	75	100	125	150
075 (3/4")	0.250	OUT	0.442	11.0	22.1	33.1	44.2	55.2	66.3
		IN	0.399	10.0	20.0	30.0	39.9	49.9	59.9
088 (7/8")	0.250	OUT	0.608	15.2	30.4	45.6	60.8	76.0	91.2
		IN	0.566	14.1	28.3	42.4	56.6	70.7	84.9
106 (1-1/16")	0.375	OUT	0.882	22.1	44.1	66.2	88.2	110.3	132.4
		IN	0.787	19.7	39.3	59.0	78.7	98.3	118.0
125 (1-1/4")	0.437	OUT	1.227	30.7	61.4	92.0	122.7	153.4	184.1
		IN	1.098	27.4	54.9	82.3	109.8	137.2	164.6
150 (1-1/2")	0.437	OUT	1.767	44.2	88.4	132.5	176.7	220.9	265.1
		IN	1.638	40.9	81.9	122.8	163.8	204.7	245.6

Weight

(lbs)

Bore size (inch)	Base weight by mounting style			Add'l weight per inch stroke	Add'l weight for magnet	Add'l weight for bumper
	B	C	E			
075 (3/4")	0.200	0.200	0.280	0.035	0.008	0.012
088 (7/8")	0.208	0.188	0.278	0.038	0.010	0.012
106 (1-1/16")	0.340	0.330	0.420	0.063	0.012	0.011
125 (1-1/4")	0.541	0.591	0.691	0.083	0.020	0.029
150 (1-1/2")	0.720	0.820	0.860	0.104	0.024	0.020

Dimensions: X169US - Basic / Double End / Double Rod

Basic

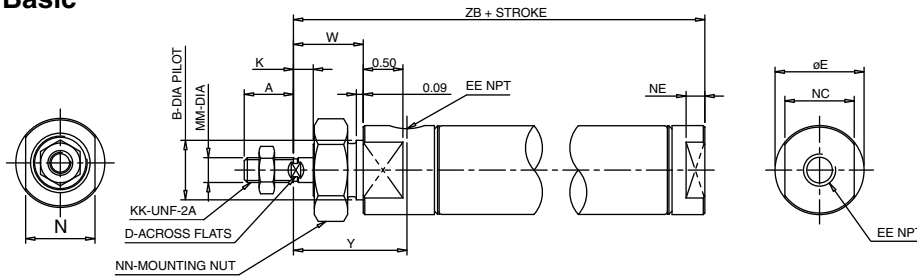

With Bumper

Bore size (inch)	ZB
075 (3/4")	3.68
106 (1-1/16")	3.86
125 (1-1/4")	4.10
150 (1-1/2")	4.18
200 (2")	5.23

Without Bumper

(inch)

Bore size (inch)	A	B	D	øE	EE	K	KK	øMM	N	NC	NE	NN	W	Y	ZB
075 (3/4")	0.59	0.624 ⁰ _{-0.003}	0.22	0.86	1/8	0.25	1/4 -28	0.250	0.75	0.62	0.12	5/8 -18	0.75	1.21	3.42
106 (1-1/16")	0.62	0.749 ⁰ _{-0.003}	0.25	1.12	1/8	0.25	5/16 -24	0.312	0.88	0.88	0.24	3/4 -16	0.88	1.43	3.66
125 (1-1/4")	0.75	0.874 ⁰ _{-0.003}	0.38	1.32	1/8	0.25	3/8 -24	0.437	1.06	1.06	0.25	7/8 -14	1.00	1.75	3.84
150 (1-1/2")	0.88	0.999 ⁰ _{-0.002}	0.38	1.56	1/4	0.25	7/16 -20	0.437	1.25	1.25	0.25	1-14	1.06	1.69	3.98
200 (2")	1.00	1.249 ⁰ _{-0.003}	0.50	2.07	1/4	0.31	1/2 -20	0.625	1.75	1.75	0.31	1-1/4 -12	1.31	2.04	4.97

Double end

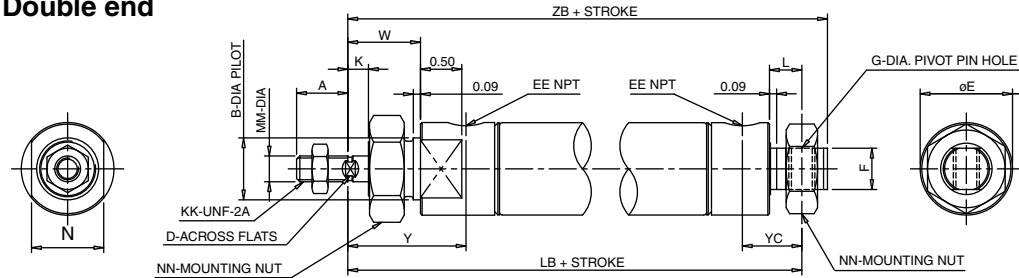

With Bumper

Bore size (inch)	LB	ZB
075 (3/4")	4.57	4.85
106 (1-1/16")	4.73	5.04
125 (1-1/4")	4.88	5.26
150 (1-1/2")	5.32	5.79
200 (2")	6.38	6.82

Without Bumper

(inch)

Bore size (inch)	A	B	D	øE	EE	F	øG	K	KK	L	LB	øMM	N	NN	W	Y	YC	ZB
075 (3/4")	0.59	0.624 ⁰ _{-0.003}	0.22	0.86	1/8	0.44	0.220	0.25	1/4 -28	0.34	4.31	0.250	0.75	5/8 -18	0.75	1.21	0.62	4.59
106 (1-1/16")	0.62	0.749 ⁰ _{-0.003}	0.25	1.12	1/8	0.50	0.253	0.25	5/16 -24	0.38	4.47	0.312	0.88	3/4 -16	0.88	1.43	0.62	4.78
125 (1-1/4")	0.75	0.874 ⁰ _{-0.003}	0.38	1.32	1/8	0.62	0.315	0.25	3/8 -24	0.47	4.62	0.437	1.06	7/8 -14	1.00	1.75	0.81	5.00
150 (1-1/2")	0.88	0.999 ⁰ _{-0.002}	0.38	1.56	1/4	0.69	0.377	0.25	7/16 -20	0.56	5.06	0.437	1.25	1-14	1.06	1.69	0.97	5.53
200 (2")	1.00	1.249 ⁰ _{-0.003}	0.50	2.07	1/4	0.86	0.439	0.31	1/2 -20	0.56	6.12	0.625	1.75	1-1/4 -12	1.31	2.04	1.03	6.56

Double rod

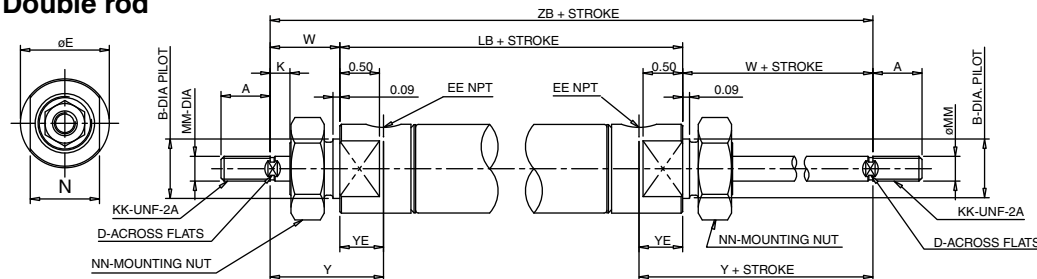

With Bumper

Bore size (inch)	LB	ZB
075 (3/4")	3.67	5.17
106 (1-1/16")	3.69	5.45
125 (1-1/4")	3.64	5.64
150 (1-1/2")	3.89	6.01
200 (2")	4.76	7.30

Without Bumper

(inch)

Bore size (inch)	A	B	D	øE	EE	K	KK	LB	øMM	N	NN	W	Y	YE	ZB
075 (3/4")	0.59	0.624 ⁰ _{-0.003}	0.22	0.86	1/8	0.25	1/4 -28	3.41	0.250	0.75	5/8 -18	0.75	1.21	0.45	4.91
106 (1-1/16")	0.62	0.749 ⁰ _{-0.003}	0.25	1.12	1/8	0.25	5/16 -24	3.43	0.312	0.88	3/4 -16	0.88	1.43	0.55	5.19
125 (1-1/4")	0.75	0.874 ⁰ _{-0.003}	0.38	1.32	1/8	0.25	3/8 -24	3.38	0.437	1.06	7/8 -14	1.00	1.75	0.75	5.38
150 (1-1/2")	0.88	0.999 ⁰ _{-0.002}	0.38	1.56	1/4	0.25	7/16 -20	3.63	0.437	1.25	1-14	1.06	1.69	0.57	5.75
200 (2")	1.00	1.249 ⁰ _{-0.003}	0.50	2.07	1/4	0.31	1/2 -20	4.50	0.625	1.75	1-1/4 -12	1.31	2.04	0.72	7.12

Air Cylinder: Standard Single Acting, Spring Return/Extend Series *NCM*

How to Order

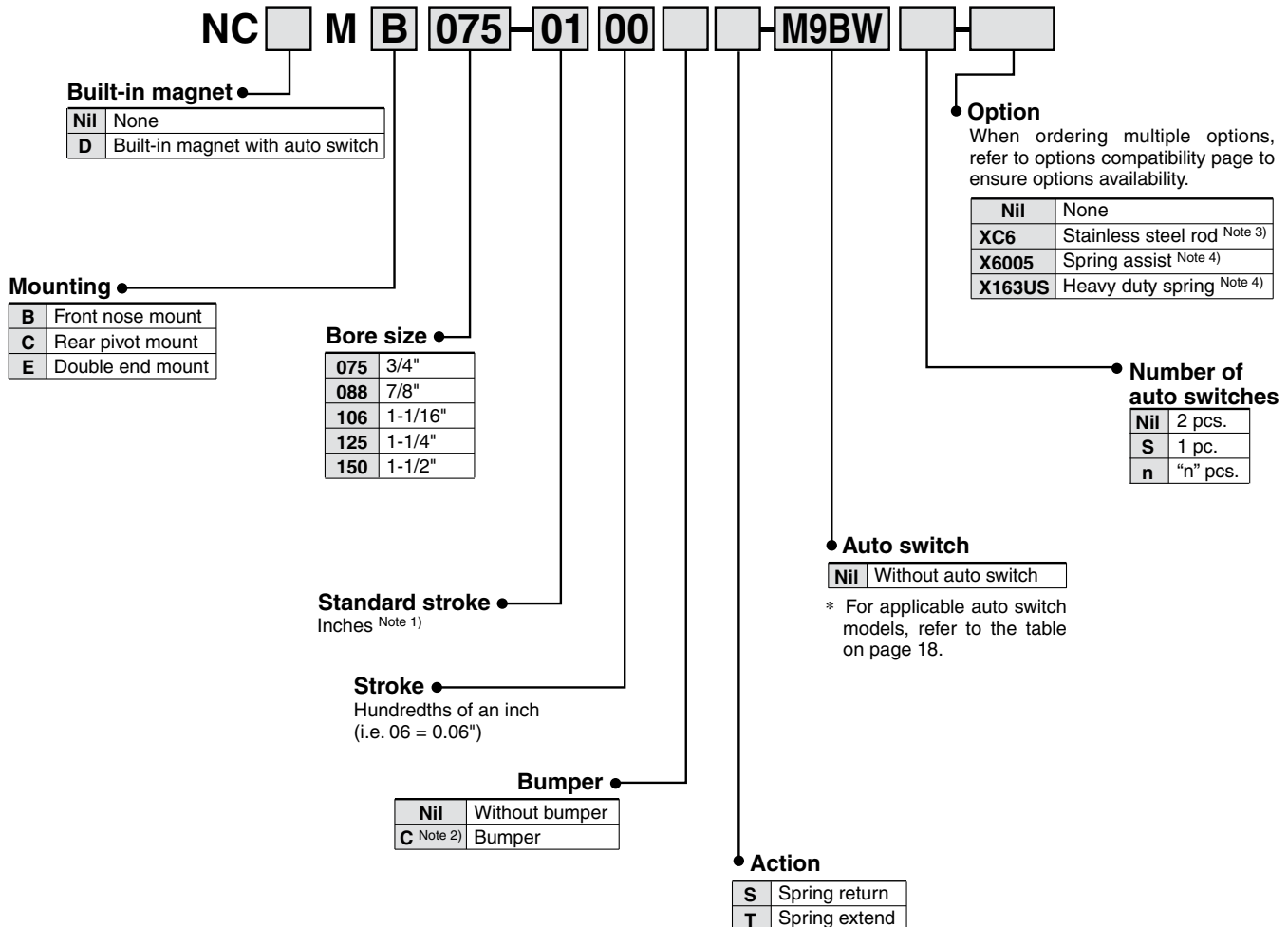

Note 1) See specifications for standard and maximum stroke lengths.

Note 2) Bumper is offered at no additional cost on $\varnothing 7/8"$ and $\varnothing 1-1/4"$. They are options on the other bore sizes. The "C" after the bore size must be included in either case. Bumper affects cylinder overall length of some models. Refer to the dimensional data.

Note 3) Stainless steel rod standard on $\varnothing 3/4"$ and $\varnothing 7/8"$.

Note 4) $\varnothing 3/4"$, $\varnothing 1-1/16"$ and $\varnothing 1-1/2"$ only.

Auto Switch Specifications

Applicable Auto Switches

Type	Special function	Electrical entry	Indicator/light	Wiring (Output)	Load voltage		Auto switch model	Lead wire length (m)					Pre-wired connector	Applicable load			
					DC	AC		0.5 (Nil)	1 (M)	3 (L)	5 (Z)	None (N)		IC circuit	Relay, PLC		
Solid state switch	—	Grommet	Yes	3-wire (NPN)	5V, 12V	—	M9N	●	●	●	○	—	○	IC circuit	Relay, PLC		
				3-wire (PNP)				●	●	●	○	—	○				
		Connector	2-wire	12 V	●	—	●	●	●	—	—						
	Diagnostic indication (2-color indication)	Grommet		Yes	3-wire (NPN)	24 V	5V, 12V	—	M9NW	●	●	●	○	—		○	
			3-wire (PNP)		●					●	●	○	—	○			
			2-wire		12 V					●	●	●	○	—		○	
			Water resistant (2-color indication)		2-wire					12 V	●	●	●	○		—	○
	With diagnostic output (2-color indication)	4-wire (NPN)	5V, 12V	●	—	●	○	—	○	IC circuit							
	Reed switch	—	Grommet	Yes	3-wire (NPN equivalent)	—	5 V	—	A96	●	—	●	—	—		—	IC circuit
Connector					None	2-wire	24 V	12 V	100 V	A93	●	—	●	—	—	—	—
									100 V or less	A90	●	—	●	—	—	—	IC circuit
									100 V, 200 V	B54	●	—	●	●	—	—	—
									200 V or less	B64	●	—	●	—	—	—	
			—	C73C					●	—	●	●	●	—			
Grommet			Yes	2-wire	24 V or less	—	—	—	B59W	●	—	●	—	—	—	—	

* Lead wire length symbols: 0.5 m Nil (Example) M9NW
 1 m M (Example) M9NWM
 3 m L (Example) M9NWL
 5 m Z (Example) M9NWZ
 None N (Example) H7CN

* Solid state switches marked with "○" are produced upon receipt of order.
 * D-B54, B64, and B59W cannot be mounted for bore size 044 and 056.

* For details about auto switches with pre-wired connector, refer to Best Pneumatics catalog.
 * D-A9□, M9□, M9□W are shipped together.
 (Only switch mounting bracket is assembled at the time of shipment.)
 * D-M9□M and M9□VM which lead wire length is 1 m are available from July, 2008.

Option Compatibility

Option Compatibility (1)

	Description	Note	NCDM	S	T
NCDM	Auto switch capable	1, 6	—	—	—
S	Spring return	1, 6	O	—	—
T	Spring extend	1, 6	O	N	—
C	Bumper	1, 2, 6	O	O	O
XB6	Heat resistant	1, 6	S	S	S
XB7	Cold resistant	1, 6	S	S	S
XB9	Low speed	1, 6	N	N	N
XC6	Stainless steel rod	1, 3, 6	S	S	O
B	Front nose mount	1, 6	O	O	O
C	Rear pivot mount	1, 6	O	O	O
E	Double end mount	1, 6	O	O	O
R	Block mount	1, 5, 6	S	O	O

O Combination available to order
 S Available with special request
 N Not available

Note 1) Exclude ø2".
 Note 2) Bumper no additional charge on ø7/8" and ø1-1/4".
 Note 3) Stainless steel rod standard on ø7/16", ø9/16", ø3/4" and ø7/8". Use XC6 option to get stainless steel rod nut.
 Note 4) Block mount not available in ø7/8" and ø1-1/4".
 Note 5) Block, Auto switch capable, S and T only available as special.
 Note 6) Exclude ø7/16" and ø9/16".

Option Compatibility (2)

	044	056	075	088	106	125	150	200
Single acting, Spring return (S), No bumper			○		○		○	
Single acting, Spring return (S), With bumper			○	○	○	○	○	
Single acting, Spring extend (T), No bumper			○		○		○	
Single acting, Spring extend (T), With bumper			○	○	○	○	○	
Direct single acting, Spring return (S), No bumper			○		○		○	
Direct single acting, Spring extend (T), No bumper			○		○		○	
Single acting, Spring extend (T), No bumper XC6			○		○		○	
Single acting, Spring extend (T), With bumper XC6				○		○		

Series NCM

Specifications: Single Acting, Spring Return / Spring Extend

Specifications

Bore size (inch)	075 (3/4")	088 (7/8")	106 (1-1/16")	125 (1-1/4")	150 (1-1/2")
Fluid	Air				
Maximum operating pressure	250 PSI / 1.7 MPa				
Minimum operating pressure	25 PSI / 0.18 MPa				
Ambient and fluid temperature	40 to 140°F / 5 to 60 °C				
Piston speed	2 to 20 in/sec / 50 to 500 mm/s				
Bumper	Optional (No additional charge on 7/8" and 1-1/4" bore)				
Lubrication	Not required (Pre-lubricated at factory)				
Mounting	B, C, E, R				

Note) R mount available on 3/4", 1-1/16", and 1-1/2" bore only.

Standard Stroke

(inch)

Mounting	Standard stroke	Max. stroke
Front nose mount (B)	1/2, 1, 1-1/2, 2, 3, 4	6
Rear pivot mount (C)		
Double end mount (E)		
Block mount (R)		

Note) Up to 18" available as special request.

Theoretical Output: Spring Return (S) with Standard Rod

(lbf)

Bore size (inch)	Rod diameter (inch)	Operating direction	Effective area (sq.inch)	Operating pressure (PSI)					
				25	50	75	100	125	150
075 (3/4")	0.250	OUT	0.442	8.0	19.1	30.1	41.2	52.2	63.3
		IN	–	3.0					
088 (7/8")	0.250	OUT	0.608	12.2	27.4	42.6	57.8	73.0	88.2
		IN	–	3.0					
106 (1-1/16")	0.312	OUT	0.882	19.1	41.1	63.2	85.2	107.3	129.4
		IN	–	3.0					
125 (1-1/4")	0.437	OUT	1.227	23.7	54.4	85.0	115.7	146.4	177.1
		IN	–	7.0					
150 (1-1/2")	0.437	OUT	1.767	37.2	81.4	125.5	169.7	213.9	258.1
		IN	–	7.0					

Note1) Force on extension (OUT) is shown as the theoretical force of a double acting cylinder on extension less the compressed force of the return spring.

Note 2) Force on retraction (IN) is the resting force of spring when fully retracted.

Theoretical Output: Spring Extend (T) with Standard Rod

(lbf)

Bore size (inch)	Rod diameter (inch)	Operating direction	Effective area (sq.inch)	Operating pressure (PSI)					
				25	50	75	100	125	150
075 (3/4")	0.25	OUT	–	3.0					
		IN	0.393	6.8	16.6	26.5	36.3	46.1	55.9
088 (7/8")	0.25	OUT	–	3.0					
		IN	0.559	11.0	25.0	38.9	52.9	66.9	80.9
106 (1-1/16")	0.312	OUT	–	3.0					
		IN	0.806	17.2	37.3	57.5	77.6	97.8	117.9
125 (1-1/4")	0.437	OUT	–	7.0					
		IN	1.077	19.9	46.9	73.8	100.7	127.6	154.6
150 (1-1/2")	0.437	OUT	–	7.0					
		IN	1.617	33.4	73.9	114.3	154.7	195.1	235.6

Note1) Force on retraction (IN) is shown as the theoretical force of a double acting cylinder on retraction less the compressed force of the extend spring.

Note 2) Force on extension (OUT) is the resting force of spring when fully extended.

Specifications: Single Acting, Spring Return / Spring Extend

Spring Force: Spring Return (S) and Spring Extend (T) Type Cylinders (lbs)

Bore size (inch)	Resting lbf (N)	Compressed lbf (N)
075 (3/4")	3 (13.3)	6 (26.8)
088 (7/8")	3 (13.3)	5.45(24.4)
106 (1-1/16")	3 (13.3)	6 (26.8)
125 (1-1/4")	7 (31.2)	12.4 (55.6)
150 (1-1/2")	7 (31.2)	12.4 (55.6)

Weight: Single Acting, Spring Return except Non-rotating Rod (lbs)

Bore size (inch)	Base weight by mounting style				1st inch of stroke	Add'l weight per inch stroke	Add'l weight for magnet	Add'l weight for bumper
	B	C	E	R	B, C, E	B, C, E, R		
075 (3/4")	0.148	0.164	0.224	0.224	0.044	0.078	0.008	0.006
088 (7/8")	0.194	0.182	0.264	N/A	0.047	0.086	0.010	0.019
106 (1-1/16")	0.293	0.287	0.369	0.430	0.063	0.112	0.012	0.038
125 (1-1/4")	0.514	0.518	0.644	N/A	0.108	0.220	0.020	0.042
150 (1-1/2")	0.587	0.619	0.707	1.020	0.113	0.212	0.024	0.034

Weight: Single Acting, Spring Extend except Non-rotating Rod (lbs)

Bore size (inch)	Base weight by mounting style				1st inch of stroke	Add'l weight per inch stroke	Add'l weight for magnet	Add'l weight for bumper
	B	C	E	R	B, C, E	B, C, E, R		
075 (3/4")	0.197	0.171	0.253	0.210	0.044	0.071	0.008	0.006
088 (7/8")	0.214	0.188	0.270	N/A	0.047	0.078	0.010	0.019
106 (1-1/16")	0.337	0.311	0.393	0.430	0.063	0.116	0.012	0.038
125 (1-1/4")	0.598	0.564	0.690	N/A	0.108	0.186	0.020	0.042
150 (1-1/2")	0.749	0.781	0.869	1.020	0.113	0.222	0.024	0.034

Series NCM

Construction: Single Acting, Spring Return

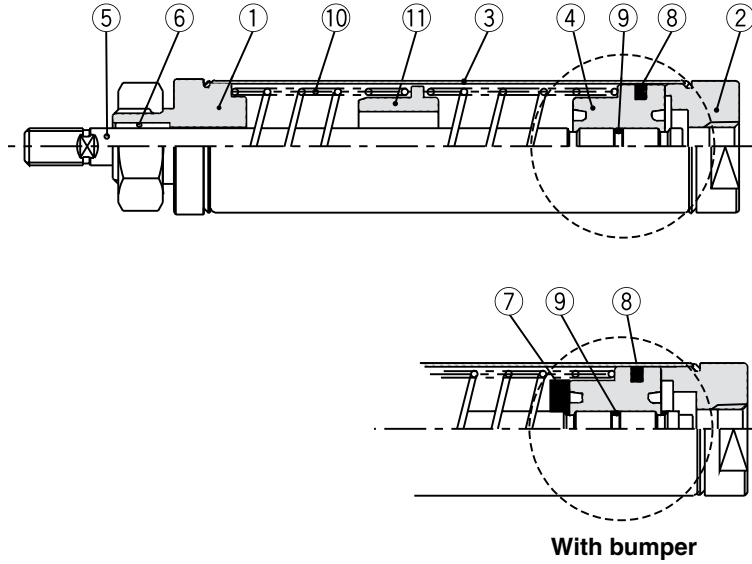

Component Parts

No.	Description	Material	Note
1	Rod cover	Aluminum alloy	Clear anodized
2	Head cover	Aluminum alloy	Clear anodized
3	Cylinder tube	Stainless steel	Stainless steel 304
4	Piston	Aluminum alloy	Chromated
5	Piston rod	3/4", 7/8"	Stainless steel
		1-1/16", 1-1/4", 1-1/2"	Carbon steel
6	Bushing	Sintered Bronze	
7	Bumper	Urethane	
8	Piston seal	NBR	
9	Piston gasket	NBR	
10	Spring	Music wire	Chromated
11	Spring guide	Aluminum alloy	Chromated

Construction: Single Acting, Spring Extend

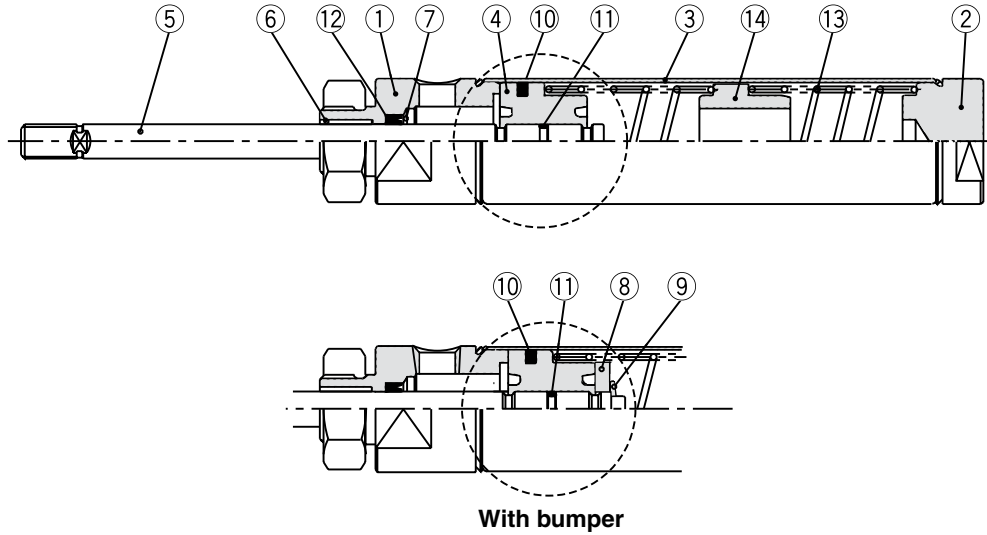

Component Parts

No.	Description	Material	Note
1	Rod cover	Aluminum alloy	Clear anodized
2	Head cover	Aluminum alloy	Clear anodized
3	Cylinder tube	Stainless steel	Stainless steel 304
4	Piston	Aluminum alloy	Chromated
5	Piston rod	3/4", 7/8"	Stainless steel
		1-1/16", 1-1/4", 1-1/2"	Carbon steel
6	Bushing	Sintered Bronze	
7	Retaining ring	Spring steel	
8	Bumper	Urethane	
9	Retaining ring	Spring steel	
10	Piston seal	NBR	
11	Piston gasket	NBR	
12	Rod seal	NBR	
13	Spring	Music wire	Chromated
14	Spring guide	Aluminum alloy	Chromated

Series NCM

Dimensions: Single Acting, Spring Return

Front nose mount / Spring return NCMB _ _ S

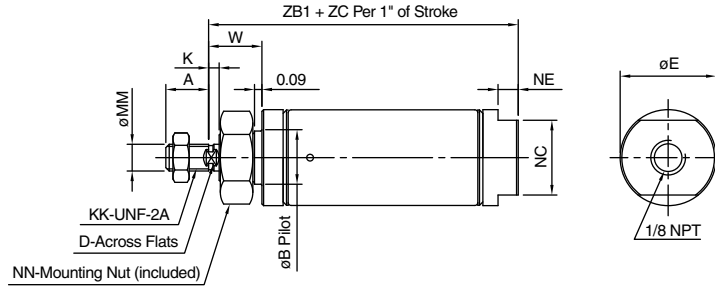

Double end mount / Spring return NCME _ _ S

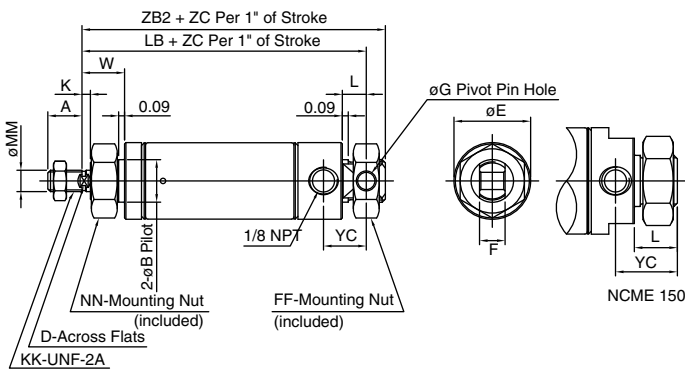

Rear pivot mount / Spring return NCMC _ _ S

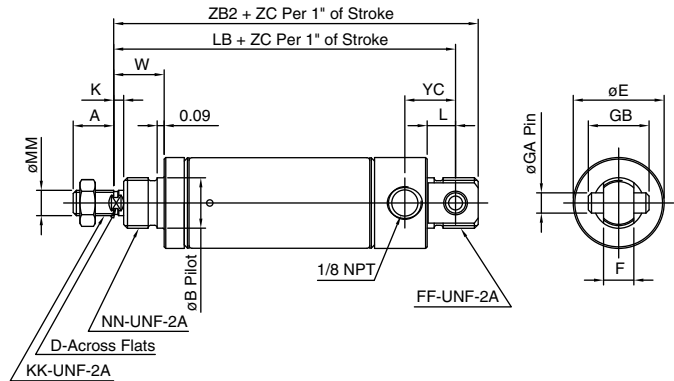

(inch)

Bore size (inch)	MM	KK	A	B	D	E	F	FF	G	GA	GB	K	L	NC	NE	NN	W	YC	ZC
075 (3/4")	0.250	1/4-28	0.50	0.496 ⁰ _{-0.003}	—	0.86	0.38	5/8-18	0.251	0.250	0.75	—	0.34	0.62	0.12	1/2-20	0.44	0.62	1.69
088 (7/8")	0.250	1/4-28	0.50	0.624 ⁰ _{-0.003}	—	0.93	0.38	5/8-18	0.251	0.250	0.75	—	0.34	0.75	0.18	5/8-18	0.50	0.62	1.56
106 (1-1/16")	0.312	5/16-24	0.50	0.624 ⁰ _{-0.003}	0.25	1.12	0.38	5/8-18	0.251	0.250	0.75	0.12	0.34	0.88	0.24	5/8-18	0.62	0.62	1.56
125 (1-1/4")	0.437	7/16-20	0.75	0.749 ⁰ _{-0.003}	0.38	1.32	0.50	3/4-16	0.251	0.250	0.75	0.25	0.41	1.06	0.25	3/4-16	0.88	0.78	1.81
150 (1-1/2")	0.437	7/16-20	0.75	0.749 ⁰ _{-0.003}	0.38	1.56	0.62	3/4-16	—	0.375	1.00	0.25	0.50	1.25	0.25	3/4-16	0.88	0.78	1.69

Note 1) F dimension for NCME150 not applicable. There are no flats on the E type 150 bore rear tang.

Note 2) FF dimension for NCMC 150 is not applicable. There are no threads on the C type 150 bore rear tang.

Single Acting, Spring Return (B/C/E) Mount without Magnet

Bore size (inch)	LB		ZB1		ZB2	
	No bumper	With bumper	No bumper	With bumper	No bumper	With bumper
075 (3/4")	2.28	2.41	1.50	1.63	2.56	2.69
088 (7/8")	2.35	2.47	1.72	1.84	2.63	2.75
106 (1-1/16")	2.66	2.79	2.06	2.19	2.94	3.07
125 (1-1/4")	3.25	3.38	2.53	2.66	3.66	3.78
150 (1-1/2")	3.12	3.25	2.44	2.57	3.50	3.63

Note) LB dimension for NCME150 not applicable.

X155US (without clevis pin)

Bore size (inch)	ϕG
075 (3/4")	0.251
088 (7/8")	0.251
106 (1-1/16")	0.251
125 (1-1/4")	0.251
150 (1-1/2")	0.378

Single Acting, Spring Return (B/C) Mount with Magnet

Bore size (inch)	LB		ZB1		ZB2	
	No bumper	With bumper	No bumper	With bumper	No bumper	With bumper
075 (3/4")	2.41	2.53	1.63	1.75	2.69	2.81
088 (7/8")	2.47	2.59	1.84	1.97	2.75	2.88
106 (1-1/16")	2.79	2.91	2.19	2.32	3.06	3.19
125 (1-1/4")	3.38	3.50	2.66	2.78	3.79	3.91
150 (1-1/2")	3.25	3.38	2.56	2.68	3.63	3.75

Single Acting, Spring Return (E) Mount with Magnet

Bore size (inch)	LB		ZB2	
	No bumper	With bumper	No bumper	With bumper
075 (3/4")	2.41	2.53	2.69	2.81
088 (7/8")	2.47	2.59	2.75	2.88
106 (1-1/16")	2.79	2.91	3.06	3.19
125 (1-1/4")	3.38	3.50	3.79	3.91
150 (1-1/2")	—	—	3.38	3.50

Dimensions: Single Acting, Spring Extend

Front nose mount / Spring extend NCMB_ _ T

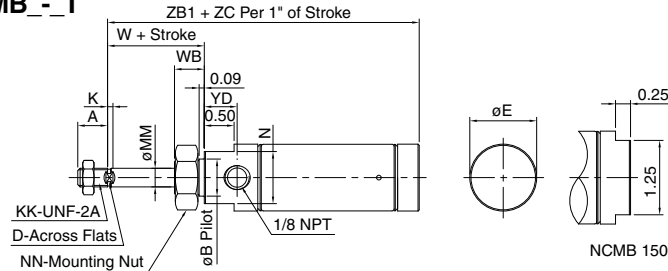

Double end mount / Spring extend NCME_ _ T

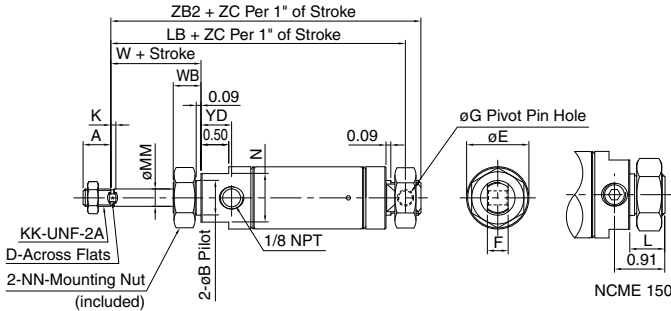

Rear pivot mount / Spring extend NCMC_ _ T

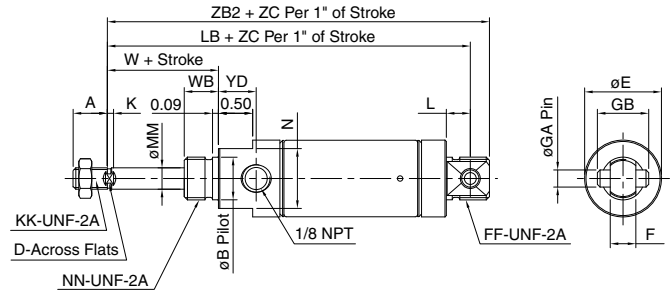

Bore size (inch)	MM	KK	A	B	D	E	F	FF	G	GA	GB	K	L	LB	N	NN	W	WB	YD	ZC
075 (3/4")	0.250	1/4-28	0.50	0.624 ⁰ _{-0.003}	-	0.86	0.38	5/8-18	0.251	0.250	0.75	-	0.34	2.44	0.75	5/8-18	0.50	0.50	0.45	2.69
088 (7/8")	0.250	1/4-28	0.50	0.624 ⁰ _{-0.003}	-	0.93	0.38	5/8-18	0.251	0.250	0.75	-	0.34	2.62	0.75	5/8-18	0.50	0.50	0.45	2.56
106 (1-1/16")	0.312	5/16-24	0.50	0.624 ⁰ _{-0.003}	0.25	1.12	0.38	5/8-18	0.251	0.250	0.75	0.12	0.34	2.78	0.88	5/8-18	0.62	0.50	0.55	2.81
125 (1-1/4")	0.437	7/16-20	0.75	0.749 ⁰ _{-0.003}	0.38	1.32	0.50	3/4-16	0.251	0.250	0.75	0.25	0.41	3.76	1.06	3/4-16	0.88	0.62	0.75	2.81
150 (1-1/2")	0.437	7/16-20	0.75	0.749 ⁰ _{-0.003}	0.38	1.56	0.62	-	-	0.375	1.00	0.25	0.63	3.88	1.25	3/4-16	0.88	0.62	0.63	3.00

Note 1) F dimension for NCME150 not applicable. There are no flats on the E type 150 bore rear tang.
 Note 2) FF dimension for NCMC 150 is not applicable. There are no threads on the C type 150 bore rear tang.

Single Acting, Spring Extend (B/C/E) Mount without Magnet

Bore size (inch)	LB		ZB1		ZB2	
	No bumper	With bumper	No bumper	With bumper	No bumper	With bumper
075 (3/4")	2.44	2.56	2.10	2.22	2.72	2.84
088 (7/8")	2.50	2.62	2.15	2.27	2.78	2.91
106 (1-1/16")	2.78	2.91	2.42	2.55	3.06	3.19
125 (1-1/4")	3.64	3.76	3.22	3.34	4.04	4.16
150 (1-1/2")	3.88	4.00	3.16	3.29	4.26	4.39

Note) LB dimension for NCME150 not applicable.

X155US (without clevis pin)

Bore size (inch)	øG
075 (3/4")	0.251
088 (7/8")	0.251
106 (1-1/16")	0.251
125 (1-1/4")	0.251
150 (1-1/2")	0.378

Single Acting, Spring Extend (B/C) Mount with Magnet

Bore size (inch)	LB		ZB1		ZB2	
	No bumper	With bumper	No bumper	With bumper	No bumper	With bumper
075 (3/4")	2.56	2.69	2.23	2.36	2.85	2.97
088 (7/8")	2.62	2.75	2.27	2.40	2.91	3.03
106 (1-1/16")	2.91	3.03	2.55	2.68	3.19	3.31
125 (1-1/4")	3.76	3.88	3.34	3.47	4.16	4.29
150 (1-1/2")	4.00	4.12	3.29	3.41	4.38	4.50

Single Acting, Spring Extend (E) Mount with Magnet

Bore size (inch)	LB		ZB2	
	No bumper	With bumper	No bumper	With bumper
075 (3/4")	2.56	2.69	2.85	2.97
088 (7/8")	2.62	2.75	2.91	3.03
106 (1-1/16")	2.91	3.03	3.19	3.31
125 (1-1/4")	3.76	3.88	4.16	4.21
150 (1-1/2")	-	-	4.12	4.25

Note) LB dimension for NCME150 not applicable.

Air Cylinder: Non-rotating Rod Single Acting, Spring Return

Series *NCM*

How to Order

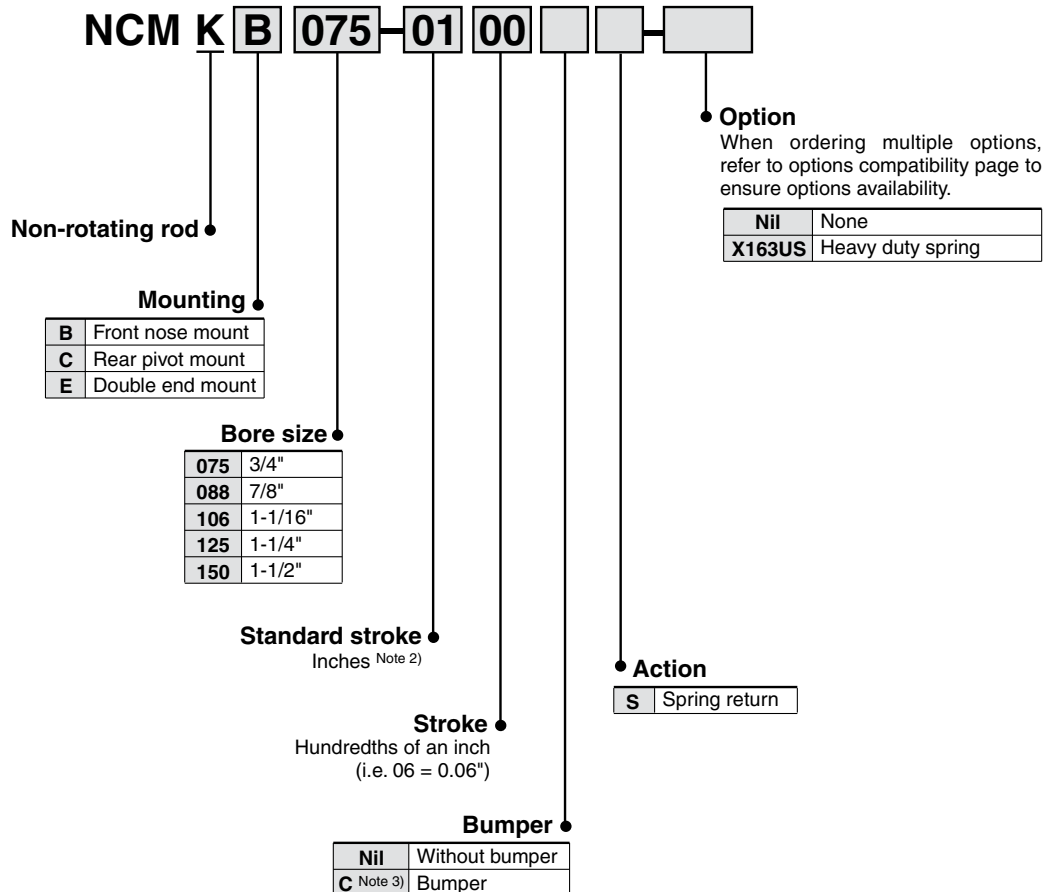

Note 1) Not available with double rod (W), block mount (R), rod boot.

Note 2) See specifications for standard and maximum stroke lengths.

Note 3) Bumper is offered at no additional cost on $\phi 7/8$ " and $\phi 1-1/4$ ". They are options on the other bore sizes. The "C" after the bore size must be included in either case. Bumper affects cylinder overall length of some models. Refer to the dimensional data.

Option Compatibility

Option Compatibility (1)

	Description	Note	NCMK-S	NCMK-T	C
NCMK-S	Spring return	1, 3	-		
NCMK-T	Spring extend	1, 3	N	-	
C	Bumper	1, 2, 3	O	O	-
B	Front nose mount	1, 3	O	O	O
C	Rear pivot mount	1, 3	O	O	O
E	Double end mount	1, 3	O	O	O

O Combination available to order

S Available with special request

N Not available

Note 1) Exclude ø2".

Note 2) Bumper no additional charge on ø7/8" and ø1-1/4".

Note 3) Exclude ø7/16" and ø9/16".

Option Compatibility (2)

	044	056	075	088	106	125	150	200
Single acting, Spring return (S), Non-rotating rod, No bumper			O		O		O	
Single acting, Spring return (S), Non-rotating rod, With bumper			O	O	O	O	O	

Series NCM

Specifications: Single Acting, Spring Return Non-rotating Rod

Specifications

Bore size (inch)	075 (3/4")	088 (7/8")	106 (1-1/16")	125 (1-1/4")	150 (1-1/2")
Fluid	Air				
Maximum operating pressure	250 PSI / 1.7 MPa				
Minimum operating pressure	25 PSI / 0.18 MPa				
Ambient and fluid temperature	40 to 140°F / 5 to 60 °C				
Piston speed	2 to 20 in/sec / 50 to 500 mm/s				
Rod material	Stainless steel 303				
Bumper	Optional (No additional charge on 7/8" and 1-1/4" bore)				
Non-rotating accuracy	± 2.0°		± 1.4°		
Maximum allowable torque	0.04 ft·Lbf (0.06 N·m)	0.09 ft·Lbf (0.13 N·m)	0.12 ft·Lbf (0.16 N·m)		

Standard Stroke

(inch)

Mounting	Standard stroke	Max. stroke
Front nose mount (B)	1/2, 1, 2, 3, 4, 5, 6	6
Double end mount (E)	1/2, 1, 2, 3, 4, 5, 6	6
Rear pivot mount (C)	1/2, 1, 2, 3, 4, 5, 6	

Note 1) Minimum stroke for mounting auto switches: 0.6 inch for 2 switches, 0.4 inch for one switch.

Note 2) Spring return up to 18" available as special request.

Theoretical Output

(lbf)

Bore size (inch)	Rod diameter (inch)	Operating direction	Effective area (sq.inch)	Operating pressure (PSI)					
				25	50	75	100	125	150
075 (3/4")	0.25	OUT	0.442	8.0	19.1	30.1	41.2	52.2	63.3
		IN	–	3.0					
088 (7/8")	0.25	OUT	0.608	12.2	27.4	42.6	57.8	73.0	88.2
		IN	–	3.0					
106 (1-1/16")	0.375	OUT	0.882	19.1	41.1	63.2	85.2	107.3	129.4
		IN	–	3.0					
125 (1-1/4")	0.437	OUT	1.227	23.7	54.4	85.0	115.7	146.4	177.1
		IN	–	7.0					
150 (1-1/2")	0.437	OUT	1.767	37.2	81.4	125.5	169.7	213.9	258.1
		IN	–	7.0					

Note 1) Force on extension (OUT) is shown as the theoretical force of a double acting non-rotating rod cylinder on extension less the compressed force of the return spring.

Note 2) Force on retraction (IN) is the resting force of spring when fully retracted.

Weight

(lbs)

Bore size (inch)	Base weight by mounting style			1st Inch of stroke	Add'l weight per inch stroke	Add'l weight for bumper
	B	C	E			
075 (3/4")	0.143	0.159	0.219	0.045	0.080	0.006
088 (7/8")	0.216	0.204	0.286	0.047	0.086	0.019
106 (1-1/16")	0.287	0.281	0.363	0.075	0.138	0.038
125 (1-1/4")	0.490	0.494	0.620	0.112	0.224	0.042
150 (1-1/2")	0.582	0.574	0.742	0.118	0.248	0.032

Dimensions: Single Acting, Spring Return Non-rotating Rod

Front nose mount / Spring return NCMB - _ S

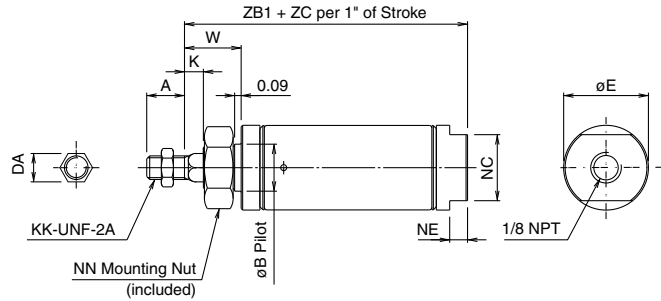

Double end mount / Spring return NCME - _ S

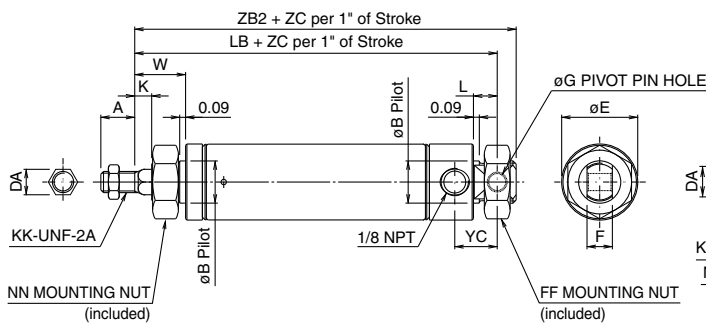

Rear pivot mount / Spring return NCMC - _ S

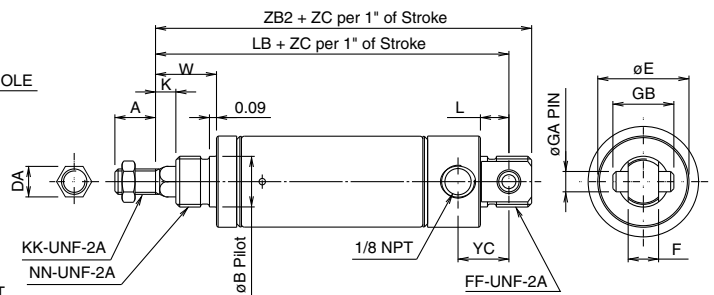

(inch)

Bore size (inch)	KK	A	B	BC	DA	E	F	FF	G	GA	GB	K	L	NC	NE	NN	W	YC	ZC
075 (3/4")	1/4-28	0.50	0.496 _{-0.003}	0.624 _{-0.003}	0.25	0.86	0.38	5/8-18	0.251	0.250	0.75	0.25	0.34	0.62	0.12	1/2-20	0.69	0.62	1.69
088 (7/8")	1/4-28	0.50	0.624 _{-0.003}	0.624 _{-0.003}	0.25	0.93	0.38	5/8-18	0.251	0.250	0.75	0.25	0.34	0.75	0.18	5/8-18	0.75	0.62	1.56
106 (1-1/16")	5/16-24	0.50	0.624 _{-0.003}	0.624 _{-0.003}	0.38	1.12	0.38	5/8-18	0.251	0.250	0.75	0.25	0.34	0.88	0.24	5/8-18	0.75	0.62	1.56
125 (1-1/4")	7/16-20	0.88	0.749 _{-0.003}	0.749 _{-0.003}	0.44	1.32	0.50	3/4-16	0.251	0.250	0.75	0.25	0.41	1.06	0.25	3/4-16	0.88	0.78	1.81
150 (1-1/2")	7/16-20	0.88	0.749 _{-0.003}	0.749 _{-0.003}	0.44	1.56	0.62	3/4-16	-	0.375	1.00	0.38	0.50	1.25	0.25	3/4-16	1.00	0.91	1.69

Note 1) F dimension for NCME150 not applicable. There are no flats on the E type 150 bore rear tang.

Note 2) FF dimension for NCMC 150 is not applicable. There are no threads on the C type 150 bore rear tang.

Single Acting, Spring Return (B/C/E) Mount without Magnet

Bore size (inch)	LB		ZB1		ZB2	
	No bumper	With bumper	No bumper	With bumper	No bumper	With bumper
075 (3/4")	2.53	-	1.75	-	2.80	-
088 (7/8")	-	2.72	-	2.09	-	3.00
106 (1-1/16")	2.78	-	2.19	-	3.06	-
125 (1-1/4")	-	3.38	-	2.66	-	3.77
150 (1-1/2")	3.25	-	2.56	-	3.25	-

Note) LB dimension for NCME150 not applicable.

X155US (without clevis pin)

Bore size (inch)	ϕG
075 (3/4")	0.251
088 (7/8")	0.251
106 (1-1/16")	0.251
125 (1-1/4")	0.251
150 (1-1/2")	0.378

Single Acting, Spring Return (E) Mount with Magnet

Bore size (inch)	LB		ZB2	
	No bumper	With bumper	No bumper	With bumper
075 (3/4")	2.66	-	2.93	-
088 (7/8")	-	2.85	-	3.13
106 (1-1/16")	2.92	-	3.19	-
125 (1-1/4")	-	3.50	-	3.91
150 (1-1/2")	-	-	3.38	-

Series NCM

High Temperature -XB6 Option



- High temperature up to 300°F
- Double acting only

Specifications

Bore size (inch)	075 (3/4")	088 (7/8")	106 (1-1/16")	125 (1-1/4")	150 (1-1/2")
Fluid	Air				
Max. operating pressure	250 PSI / 1.7 MPa				
Min. operating pressure	8 PSI / 0.06 MPa				
Ambient and fluid temp.	-4 to 300°F / -20 to 150°C				
Piston speed	2 to 20 in/sec / 50 to 500 mm/s				
Bumper	Not available				
Action	Double acting				
Auto switch capable	Special order only				

Standard Stroke

(inch)

Mounting	Standard stroke	Max. stroke
Front nose (B)	1/2, 1, 1-1/2, 2, 3, 4, 5, 6	6
Rear pivot, Double end (C, E)	1/2, 1, 1-1/2, 2, 3, 4, 5, 6, 8, 10, 12	12

How to Order

NCM **Mounting** **Bore** — **Stroke** **Option** — XB6

Ex.) NCMB 075-0400-**XB6**

High temperature

Low Temperature -XB7 Option



- Low temperature down to -22°F
- Double acting only

Specifications

Bore size (inch)	075 (3/4")	088 (7/8")	106 (1-1/16")	125 (1-1/4")	150 (1-1/2")
Fluid	Air				
Max. operating pressure	250 PSI / 1.7 MPa				
Min. operating pressure	8 PSI / 0.06 MPa				
Ambient and fluid temp.	-22 to 158°F / -30 to 70°C				
Piston speed	2 to 20 in/sec / 50 to 500 mm/s				
Bumper	Not available				
Action	Double acting				
Auto switch capable	Special order only				

Standard Stroke

(inch)

Mounting	Standard stroke	Max. stroke
Front nose (B)	1/2, 1, 1-1/2, 2, 3, 4, 5, 6	6
Rear pivot, Double end (C, E)	1/2, 1, 1-1/2, 2, 3, 4, 5, 6, 8, 10, 12	12

How to Order

NCM **Mounting** **Bore** — **Stroke** **Option** — XB7

Ex.) NCMB 075-0400-**XB7**

Low temperature

Heavy Duty Wiper -XC4 Option



- Rod wiper option

Specifications

Bore size (inch)	075 (3/4")	088 (7/8")	106 (1-1/16")	125 (1-1/4")	150 (1-1/2")	200 (2")
Fluid	Air					
Max. operating pressure	250 PSI / 1.7 MPa					
Min. operating pressure	8 PSI / 0.06 MPa					
Ambient and fluid temp.	40 to 140°F / 5 to 60°C					
Piston speed	No bumper: 2 to 20 in/sec (50 to 500 mm/sec)					
	Bumper: 2 to 30 in/sec (50 to 750 mm/sec)					
Bumper	Optional					
Lubrication	Not required (Pre-lubricated at factory)					
Auto switch capable	Optional					
Mounting	B, C, E					

Standard Stroke

Mounting	Standard stroke	Max. stroke
Front nose (B)	1/2, 1, 2, 3, 4, 5, 6	12
Rear pivot (C)		32
Double end mount (E)		

How to Order

NC(D)M **Mounting** **Bore** — **Stroke** **Option** — XC4

Ex.) NCDME075-0400-M9B-XC4

Series NCM

Stainless Steel Rod -XC6 Option



- Stainless steel piston rod is used to protect in harsh or wet environments.
- Auto switch capable
- Stainless steel rod is a standard on bores 3/4 and 7/8 and non-rotating rod.
Add -XC6 to obtain stainless steel rod nut.

Specifications

Bore size (inch)	075 (3/4")	088 (7/8")	106 (1-1/16")	125 (1-1/4")	150 (1-1/2")	200 (2")
Fluid	Air					
Max. operating pressure	250 PSI / 1.7 MPa					
Min. operating pressure	8 PSI / 0.06 MPa					
Ambient and fluid temp.	40 to 140°F / 5 to 60°C					
Piston speed	2 to 20 in/sec / 50 to 500 mm/s					
Bumper	Optional (No additional charge on 1-1/4" bore)					
Action	Double acting					
Auto switch capable	Optional					

Standard Stroke

Mounting	Standard stroke	Max. stroke
Front nose (B)	1/2, 1, 1-1/2, 2, 3, 4, 5, 6	6
Rear pivot, Double end (C, E)	1/2, 1, 1-1/2, 2, 3, 4, 5, 6, 8, 10, 12	12

Note) See standard specifications for minimum and maximum strokes.

How to Order

NC(D)M **Mounting** **Bore** — **Stroke** **Option** — XC6

Ex.) NCDMB 150-0400-**XC6**

Stainless steel rod

Low Speed -XB9 Option



- Smooth movements even at 0.4 to 2.0 inch/sec.
- Double acting
- Auto switch capable

Specifications

Bore size (inch)	075 (3/4")	088 (7/8")	106 (1-1/16")	125 (1-1/4")	150 (1-1/2")
Fluid	Air				
Max. operating pressure	250 PSI / 1.7 MPa				
Min. operating pressure	8 PSI / 0.06 MPa				
Ambient and fluid temp.	40 to 140°F / 5 to 60°C				
Piston speed	0.4 to 20 in/sec / 10 to 500 mm/s				
Bumper	Optional (No additional charge on 7/8" and 1-1/4" bore)				
Action	Double acting				
Auto switch capable	Optional				

Standard Stroke

Mounting	Standard stroke	Max. stroke
Front nose (B)	1/2, 1, 1-1/2, 2, 3, 4, 5, 6	6
Rear pivot, Double end (C, E)	1/2, 1, 1-1/2, 2, 3, 4, 5, 6, 8, 10, 12	12

Note) See standard specifications for minimum and maximum strokes.

How to Order

NCM **Mounting** **Bore** — **Stroke** **Option** — XB9

Ex.) NCDMB 075-0400-**XB9**

Low speed

Rod Boot Option



Rod Boot Material

Mounting	Material	Max. temperature
J	Tarpaulin	140°F (60°C)
K	Heat resistant tarpoulin	*230°F (110°C)

* Max. temperature is for boot only.

Maximum Stroke

(inch)

Bore size	Max. stroke
3/4, 7/8, 1-1/16	12 Standard - 16 Maximum
1-1/4, 1-1/2, 2	12 Standard - 26 Maximum

- Boots are supplied to protect the surface of piston rod and rod seals in harsh or wet environments.
- Bore size 3/4", 7/8", 1-1/16", 1-1/4", 1-1/2"
- Double acting only

How to Order

NCM **Mounting** **Bore** — **Stroke** **Option J**

Ex.) NCDMB 075-0400 J

— Rod boot
J - Tarpaulin
K - Heat resistant tarpoulin

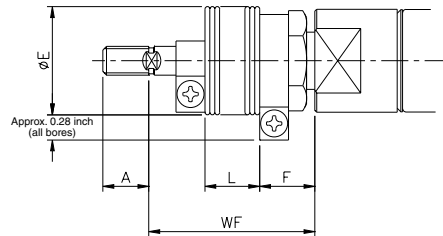

(inch)

Bore size (inch)	A	E	F	WF										
				0 to 2	2.1 to 4	4.1 to 6	6.1 to 8	8.1 to 10	10.1 to 12	12.1 to 14	14.1 to 16	16.1 to 20	20.1 to 24	24.1 to 28
075 (3/4")	0.50	1.18	0.51	1.81	2.31	2.81	3.31	3.81	4.31	4.81	5.31	-	-	-
088 (7/8")	0.50	1.18	0.51	1.81	2.31	2.81	3.31	3.81	4.31	4.81	5.31	-	-	-
106 (1-1/16")	0.50	1.18	0.51	1.81	2.31	2.81	3.31	3.81	4.31	4.81	5.31	-	-	-
125 (1-1/4")	0.75	1.38	0.55	1.94	2.44	2.94	3.44	3.94	4.44	4.94	5.44	6.44	7.44	8.44
150 (1-1/2")	0.75	1.38	0.55	1.94	2.44	2.94	3.44	3.94	4.44	4.94	5.44	6.44	7.44	8.44

(inch)

Bore size (inch)	L										
	0 to 2	2.1 to 4	4.1 to 6	6.1 to 8	8.1 to 10	10.1 to 12	12.1 to 14	14.1 to 16	16.1 to 20	20.1 to 24	24.1 to 28
075 (3/4")	0.50	1.00	1.50	2.00	2.50	3.00	3.50	4.00	-	-	-
088 (7/8")	0.50	1.00	1.50	2.00	2.50	3.00	3.50	4.00	-	-	-
106 (1-1/16")	0.50	1.00	1.50	2.00	2.50	3.00	3.50	4.00	-	-	-
125 (1-1/4")	0.50	1.00	1.50	2.00	2.50	3.00	3.50	4.00	5.00	6.00	7.00
150 (1-1/2")	0.50	1.00	1.50	2.00	2.50	3.00	3.50	4.00	5.00	6.00	7.00

Series NCM

Rotated Rear Port -X103US Option



Specifications

Bore size (inch)	075 (3/4")	088 (7/8")	106 (1-1/16")	125 (1-1/4")	150 (1-1/2")
Fluid	Air				
Max. operating pressure	250 PSI / 1.7 MPa				
Min. operating pressure	8 PSI / 0.06 MPa				
Ambient and fluid temp.	40 to 140°F / 5 to 60°C				
Piston speed	No bumper: 2 to 20 in/sec (50 to 500 mm/sec)				
	Bumper: 2 to 30 in/sec (50 to 750 mm/sec)				
Bumper	Optional				
Lubrication	Not required (Pre-lubricated at factory)				
Auto switch capable	Optional				
Mounting	B, C				

Standard Stroke

Mounting	Standard stroke	Max. stroke
Front nose (B)	1/2, 1, 2, 3, 4, 5, 6	12
Rear pivot (C)		32

How to Order

NC(D)M Mounting Bore Stroke Option X103US

Ex.) NCDMB075-0400-M9B-X103US

Rotated Rear Port -X103US Option

NC(D)MB - -X103US

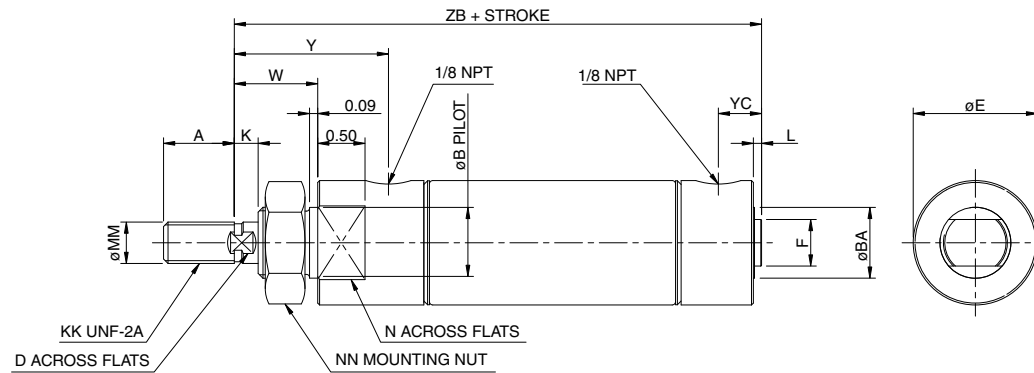

Without Bumper

Bore size (inch)	MM	KK	A	B	D	E	F	BA	K	L	N	NN	W	Y	YC	ZB
075 (3/4")	0.250	1/4-28	0.50	0.622	-	0.86	0.37	0.622	-	0.13	0.75	5/8-18	0.50	0.96	0.41	3.54
088 (7/8")	0.250	1/4-28	0.50	0.622	-	0.93	0.37	0.622	-	0.15	0.75	5/8-18	0.50	0.96	0.41	3.12
106 (1-1/16")	0.312	5/16-24	0.50	0.622	0.25	1.12	0.37	0.622	0.13	0.14	0.87	5/8-18	0.63	1.18	0.41	3.62
125 (1-1/4")	0.437	7/16-20	0.75	0.748	0.37	1.31	0.49	0.748	0.26	0.09	1.06	3/4-16	0.89	1.64	0.46	4.15
150 (1-1/2")	0.437	7/16-20	0.75	0.748	0.37	1.56	-	0.748	0.26	0.14	1.25	3/4-16	0.89	1.52	0.41	4.00

With Bumper

Bore size (inch)	ZB
075 (3/4")	3.55
088 (7/8")	3.38
106 (1-1/16")	3.76
125 (1-1/4")	4.41
150 (1-1/2")	4.14

NC(D)MC - -X103US

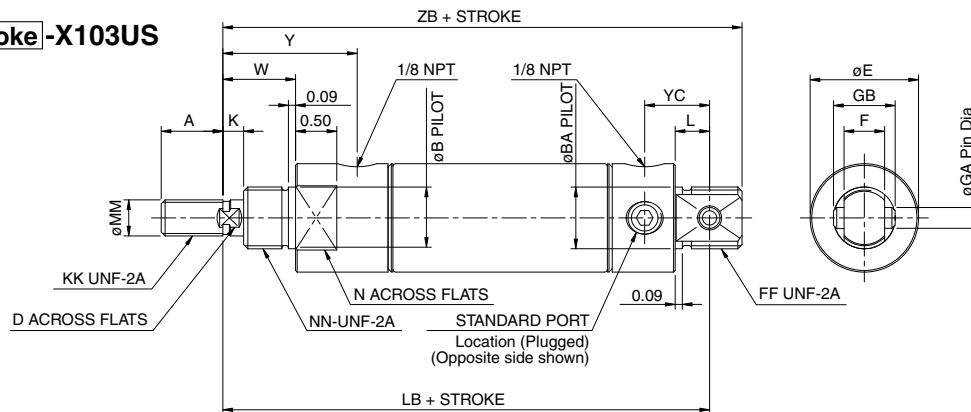

Without Bumper

Bore size (inch)	MM	KK	A	B	BA	D	E	F	FF	GA	GB	K	L	LB	N	NN	W	Y	YC	ZB
075 (3/4")	0.250	1/4-28	0.50	0.622	0.622	-	0.86	0.37	5/8-18	0.250	0.75	-	0.35	3.75	0.75	5/8-18	0.50	0.96	0.62	4.03
088 (7/8")	0.250	1/4-28	0.50	0.622	0.622	-	0.93	0.37	5/8-18	0.250	0.75	-	0.35	3.32	0.75	5/8-18	0.50	0.96	0.62	3.60
106 (1-1/16")	0.312	5/16-24	0.50	0.622	0.622	0.25	1.12	0.37	5/8-18	0.250	0.75	0.13	0.35	3.84	0.87	5/8-18	0.63	1.18	0.62	4.11
125 (1-1/4")	0.437	7/16-20	0.75	0.748	0.748	0.37	1.31	0.49	3/4-16	0.250	0.75	0.26	0.42	4.48	1.06	3/4-16	0.89	1.64	0.78	4.87
150 (1-1/2")	0.437	7/16-20	0.75	0.748	0.866	0.37	1.56	0.62	-	0.375	1.00	0.26	0.63	4.37	1.25	3/4-16	0.89	1.52	0.78	4.75

With Bumper

Bore size (inch)	LB	ZB
075 (3/4")	3.79	4.07
088 (7/8")	3.58	3.86
106 (1-1/16")	4.29	4.57
125 (1-1/4")	4.74	5.13
150 (1-1/2")	4.51	4.89

Series NCM

Rotated Rear Port -X103US Option

NC(D)MKB -X103US

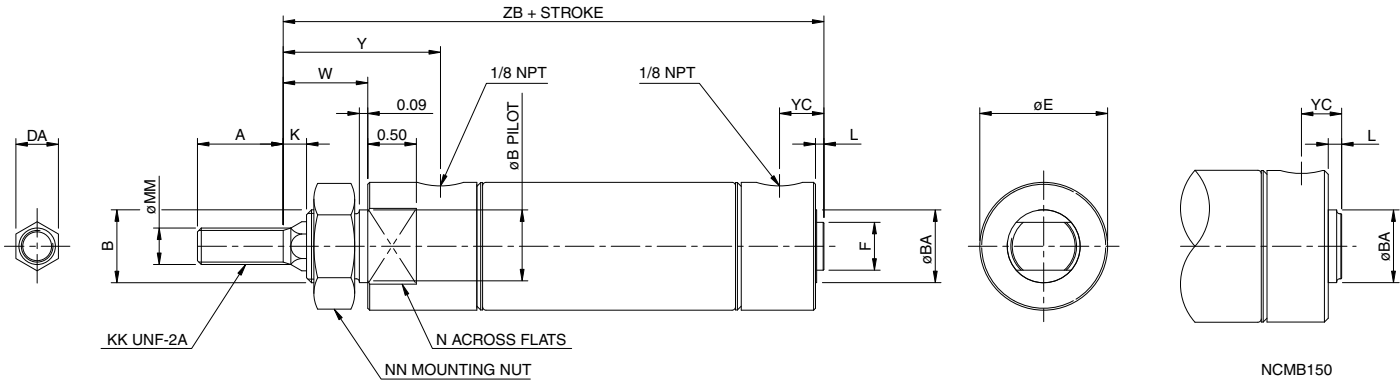

Without Bumper

Bore size (inch)	MM	KK	A	B	BA	DA	E	F	K	L	N	NN	W	Y	YC	ZB
075 (3/4")	0.250	1/4-28	0.50	0.622	0.622	0.25	0.86	0.37	0.26	0.13	0.75	5/8-18	0.76	1.21	0.41	3.79
088 (7/8")	0.250	1/4-28	0.50	0.622	0.622	0.25	0.93	0.37	0.26	0.15	0.75	5/8-18	0.76	1.21	0.41	3.37
106 (1-1/16")	0.312	5/16-24	0.50	0.622	0.622	0.38	1.12	0.37	0.26	0.14	0.88	5/8-18	0.76	1.31	0.41	3.75
125 (1-1/4")	0.375	3/8-24	0.88	0.748	0.748	0.44	1.31	0.49	0.26	0.09	1.06	3/4-16	0.89	1.64	0.46	4.15
150 (1-1/2")	0.375	3/8-24	0.88	0.874	0.748	0.44	1.56	0.62	0.38	0.14	1.25	7/8-14	1.12	1.82	0.41	4.31

With Bumper

Bore size (inch)	ZB
075 (3/4")	3.81
088 (7/8")	3.63
106 (1-1/16")	3.89
125 (1-1/4")	4.41
150 (1-1/2")	4.45

NC(D)MKC -X103US

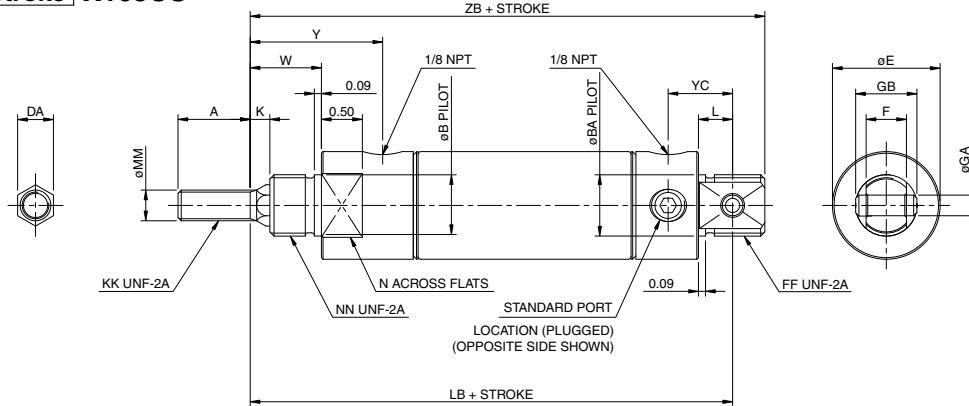

Without Bumper

Bore size (inch)	MM	KK	A	B	BA	DA	E	F	FF	GA	GB	K	L	LB	N	NN	W	Y	YC	ZB
075 (3/4")	0.250	1/4-28	0.50	0.622	0.622	0.25	0.86	0.37	5/8-18	0.250	0.75	0.26	0.35	4.02	0.75	5/8-18	0.76	1.21	0.63	4.30
088 (7/8")	0.250	1/4-28	0.50	0.622	0.622	0.25	0.93	0.37	5/8-18	0.250	0.75	0.26	0.35	3.57	0.75	5/8-18	0.76	1.21	0.61	4.11
106 (1-1/16")	0.312	5/16-24	0.50	0.622	0.622	0.38	1.12	0.37	5/8-18	0.250	0.75	0.26	0.35	3.97	0.88	5/8-18	0.76	1.31	0.63	4.39
125 (1-1/4")	0.375	3/8-24	0.88	0.748	0.748	0.44	1.31	0.49	3/4-16	0.250	0.75	0.26	0.42	4.48	1.06	3/4-16	0.89	1.64	0.79	4.13
150 (1-1/2")	0.375	3/8-24	0.88	0.874	0.748	0.44	1.56	0.62	-	0.375	1.00	0.38	0.50	4.68	1.25	7/8-14	1.12	1.82	0.78	5.06

With Bumper

Bore size (inch)	LB	ZB
075 (3/4")	4.02	4.30
088 (7/8")	3.83	4.11
106 (1-1/16")	4.11	4.39
125 (1-1/4")	4.75	5.13
150 (1-1/2")	4.82	5.20

Rear Clevis Mount without Pin with Rear Clevis Bronze Bushing -X114US Option



- Bronze bushing in place of clevis pin

Specifications

Bore size (inch)	075 (3/4")	088 (7/8")	106 (1-1/16")	125 (1-1/4")	150 (1-1/2")
Fluid	Air				
Max. operating pressure	250 PSI / 1.7 MPa				
Min. operating pressure	8 PSI / 0.06 MPa				
Ambient and fluid temp.	40 to 140°F / 5 to 60°C				
Piston speed	No bumper: 2 to 20 in/sec (50 to 500 mm/sec)				
	Bumper: 2 to 30 in/sec (50 to 750 mm/sec)				
Bumper	Optional				
Lubrication	Not required (Pre-lubricated at factory)				
Auto switch capable	Optional				
Mounting	E				

Standard Stroke

Mounting	Standard stroke	Max. stroke
Double end mount (E)	1/2, 1, 2, 3, 4, 5, 6	32

How to Order

NC(D)M -X114US

Ex.) NCDMC075-0400-M9B-X114US

NC(D)MC(075 to 0150)- (C)-X114US

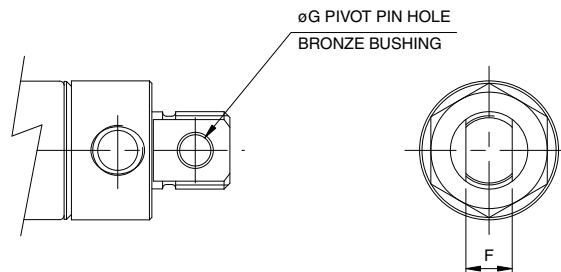

With Bumper

Bore size (inch)	F	G
075 (3/4")	0.37	0.250
088 (7/8")	0.37	0.250
106 (1-1/16")	0.37	0.250
125 (1-1/4")	0.49	0.250
150 (1-1/2")	0.62	0.375

Series NCM

Rear Pivot Mount without Clevis Pin -X155US Option



- Rear clevis mount without rear clevis pin

Specifications

Bore size (inch)	075 (3/4")	088 (7/8")	106 (1-1/16")	125 (1-1/4")	150 (1-1/2")
Fluid	Air				
Max. operating pressure	250 PSI / 1.7 MPa				
Min. operating pressure	8 PSI / 0.06 MPa				
Ambient and fluid temp.	40 to 140°F / 5 to 60°C				
Piston speed	No bumper: 2 to 20 in/sec (50 to 500 mm/sec)				
	Bumper: 2 to 30 in/sec (50 to 750 mm/sec)				
Bumper	Optional				
Lubrication	Not required (Pre-lubricated at factory)				
Auto switch capable	Optional				
Mounting	C				

Standard Stroke

Mounting	Standard stroke	Max. stroke
Rear pivot (C)	1/2, 1, 2, 3, 4, 5, 6	38

How to Order

NC(D)M Mounting Bore Stroke Option X155US

Ex.) NCDMC075-0400-M9B-X155US

Single Acting with Heavy Spring Force -X163US Option



- Single acting with heavy spring force

Specifications

Bore size (inch)	075 (3/4")	106 (1-1/16")	150 (1-1/2")
Fluid	Air		
Max. operating pressure	250 PSI / 1.7 MPa		
Min. operating pressure	8 PSI / 0.06 MPa		
Ambient and fluid temp.	40 to 140°F / 5 to 60°C		
Piston speed	No bumper: 2 to 20 in/sec (50 to 500 mm/sec)		
	Bumper: 2 to 30 in/sec (50 to 750 mm/sec)		
Bumper	Optional		
Lubrication	Not required (Pre-lubricated at factory)		
Auto switch capable	Not Available		
Mounting	B, C, E		

Spring Force: Spring Return (S) and Spring Extend (T) Type Cylinders

Bore size (inch)	Resting lbs (N)	Compressed lbs (N)
075 (3/4")	2 (8.9)	9 (40)
106 (1-1/16")	5.5 (24.5)	11.5 (51.1)
150 (1-1/2")	7.5 (33.4)	16 (71.1)

Standard Stroke

Mounting	Standard stroke	Max. stroke
Front nose (B)	1/2, 1, 2, 3, 4, 5, 6	6
Rear pivot (C)		
Double end mount (E)		

How to Order

NCM Mounting Bore Stroke Option X163US

Ex.) NCMB075-0400-X163US

Dimensional Interchange to Other Manufacturers Magnetic Reed Switch Cylinders -X169US Option



- Interchange with other manufacturers MRS cylinder

Specifications

Bore size (inch)	075 (3/4")	106 (1-1/16")	125 (1-1/4")	150 (1-1/2")	200 (2")
Fluid	Air				
Max. operating pressure	250 PSI / 1.7 MPa				
Min. operating pressure	8 PSI / 0.06 MPa				
Ambient and fluid temp.	40 to 140°F / 5 to 60°C				
Piston speed	No bumper: 2 to 20 in/sec (50 to 500 mm/sec) Bumper: 2 to 30 in/sec (50 to 750 mm/sec)				
Bumper	Optional				
Lubrication	Not required (Pre-lubricated at factory)				
Auto switch capable	Standard				
Mounting	B, E, W				

Standard Stroke

Mounting	Standard stroke (inch)	Max. stroke (inch)
Front nose (B)	1/2, 1, 2, 3, 4, 5, 6	12
Double end mount (E)		32
Double rod (W)		

How to Order

NCDM **Mounting** **Bore** — **Stroke** **Option** — **X169US**

Ex.) NCDMB075-0400-M9B-X169US

NCDMB(075 to 200)-Stroke(C)-X169US

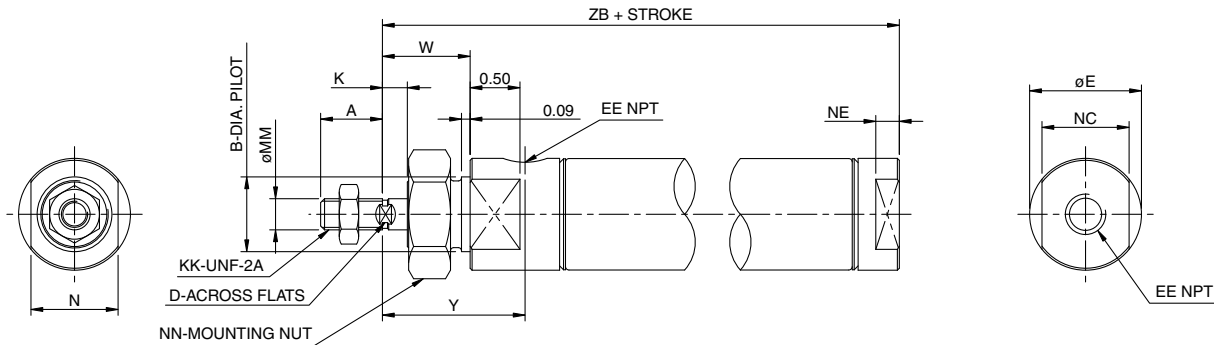

Without Bumper

Bore size (inch)	A	øB	D	øE	EE	K	KK	øMM	N	NC	NE	NN	W	Y	ZB
075 (3/4")	0.59	0.624	0.22	0.86	1/8	0.25	1/4-28	0.250	0.75	0.62	0.12	5/8-18	0.75	1.21	3.42
106 (1-1/16")	0.62	0.749	0.25	1.12	1/8	0.25	5/16-24	0.312	0.88	0.88	0.24	3/4-16	0.88	1.43	3.66
125 (1-1/4")	0.75	0.874	0.38	1.32	1/8	0.25	3/8-24	0.437	1.06	1.06	0.25	7/8-14	1.00	1.75	3.84
150 (1-1/2")	0.88	0.999	0.38	1.56	1/4	0.25	7/16-20	0.437	1.25	1.25	0.25	1-14	1.06	1.69	3.98
200 (2")	1.00	1.249	0.50	2.07	1/4	0.31	1/2-20	0.625	1.75	1.75	0.31	1 1/4-12	1.31	2.04	4.97

With Bumper

Bore size (inch)	ZB
075 (3/4")	3.68
106 (1-1/16")	3.86
125 (1-1/4")	4.10
150 (1-1/2")	4.18
200 (2")	5.23

Series NCM

Dimensional Interchange to Other Manufacturers Magnetic Reed Switch Cylinders -X169US Option

NCDME(075 to 200)-Stroke(C)-X169US

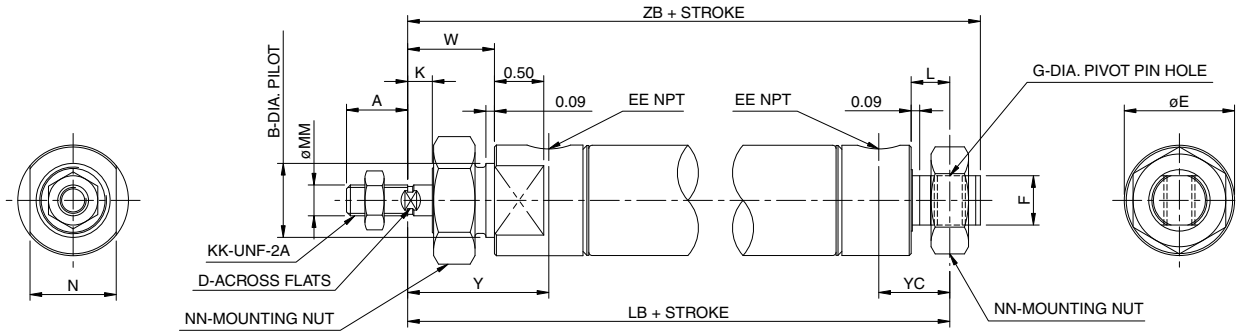

Without Bumper

Bore size (inch)	A	øB	D	øE	EE	F	øG	K	KK	L	LB	øMM	N	NN	W	Y	YC	ZB
075 (3/4")	0.59	0.624	0.22	0.86	1/8	0.44	0.220	0.25	1/4-28	0.34	4.31	0.250	0.75	5/8-18	0.75	1.21	0.62	4.59
106 (1-1/16")	0.62	0.749	0.25	1.12	1/8	0.50	0.253	0.25	5/16-24	0.38	4.47	0.312	0.88	3/4-16	0.88	1.43	0.72	4.78
125 (1-1/4")	0.75	0.874	0.38	1.32	1/8	0.62	0.315	0.25	3/8-24	0.47	4.62	0.437	1.06	7/8-14	1.00	1.75	0.81	5.00
150 (1-1/2")	0.88	0.999	0.38	1.56	1/4	0.69	0.377	0.25	7/16-20	0.56	5.06	0.437	1.25	1-14	1.06	1.69	0.97	5.53
200 (2")	1.00	1.249	0.50	2.07	1/4	0.86	0.439	0.31	1/2-20	0.56	6.12	0.625	1.75	1 1/4-12	1.31	2.04	1.03	6.56

With Bumper

Bore size (inch)	LB	ZB
075 (3/4")	4.57	4.85
106 (1-1/16")	4.73	5.04
125 (1-1/4")	4.88	5.26
150 (1-1/2")	5.32	5.79
200 (2")	6.38	6.82

NCDMW(075 to 200)-Stroke(C)-X169US

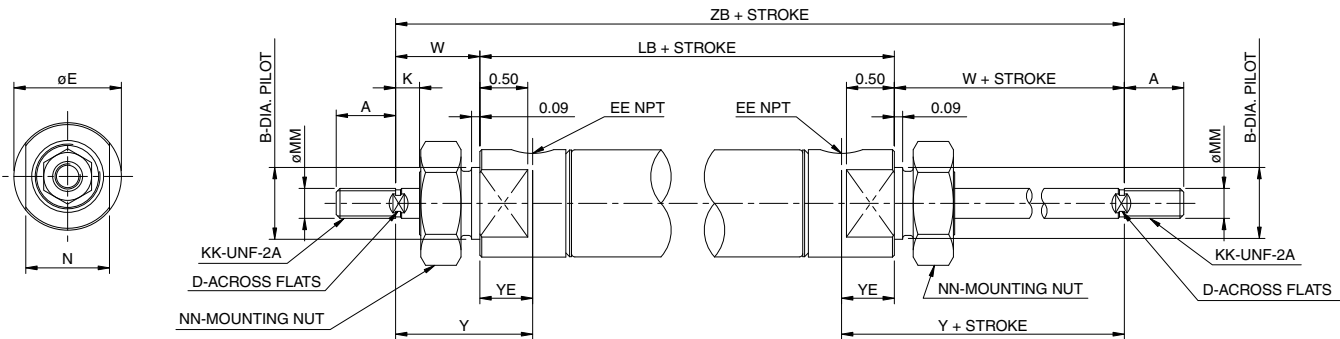

Without Bumper

Bore size (inch)	A	øB	D	øE	EE	K	KK	LB	øMM	N	NN	W	Y	YE	ZB
075 (3/4")	0.59	0.624	0.22	0.86	1/8	0.25	1/4-28	3.41	0.250	0.75	5/8-18	0.75	1.21	0.45	4.91
106 (1-1/16")	0.62	0.749	0.25	1.12	1/8	0.25	5/16-24	3.43	0.312	0.88	3/4-16	0.88	1.43	0.55	5.19
125 (1-1/4")	0.75	0.874	0.38	1.32	1/8	0.25	3/8-24	3.38	0.437	1.06	7/8-14	1.00	1.75	0.75	5.38
150 (1-1/2")	0.88	0.999	0.38	1.56	1/4	0.25	7/16-20	3.63	0.437	1.25	1-14	1.06	1.69	0.57	5.75
200 (2")	1.00	1.249	0.50	2.07	1/4	0.31	1/2-20	4.50	0.625	1.75	1 1/4-12	1.31	2.04	0.72	7.12

With Bumper

Bore size (inch)	LB	ZB
075 (3/4")	3.67	5.17
106 (1-1/16")	3.69	5.45
125 (1-1/4")	3.64	5.64
150 (1-1/2")	3.89	6.01
200 (2")	4.76	7.38

Air Tank -X6002 Option



- Air reservoir

Specifications

Bore size (inch)	075 (3/4")	088 (7/8")	106 (1-1/16")	125 (1-1/4")	150 (1-1/2")	200 (2")
Fluid	Air					
Max. operating pressure	250 PSI / 1.7 MPa					
Mounting	B, E					

Standard Length

Mounting	Standard length	Max. length
Front nose (B)	1, 2, 3, 4, 5, 6	38
Double end mount (E)		

Volume

Mounting	Bore	Standard length
Front nose (B)	075	0.51 + 0.44 per inch of length
	088	0.45 + 0.60 per inch of length
	106	0.95 + 0.88 per inch of length
	125	1.19 + 1.22 per inch of length
	150	1.83 + 1.77 per inch of length
	200	3.48 + 3.14 per inch of length
Double end mount (E)	075	0.68 + 0.44 per inch of length
	088	0.61 + 0.60 per inch of length
	106	1.08 + 0.88 per inch of length
	125	1.25 + 1.22 per inch of length
	150	1.91 + 1.77 per inch of length
	200	4.81 + 3.14 per inch of length

How to Order

NCM **Mounting** **Bore** — **Stroke** — X6002

Ex.) NCMB075-0400-X6002

NCMB(075 to 200)-**Stroke**-X6002

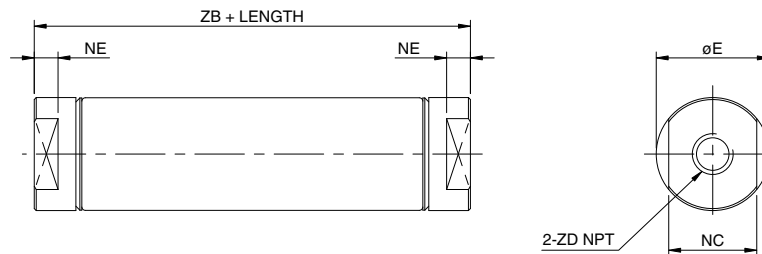

Without Bumper

Bore size (inch)	øE	NC	NE	ZB	ZD	Volume (Cubic inches)
075 (3/4")	0.86	0.62	0.12	1.95	1/8	0.51 + 0.44 per inch of length
088 (7/8")	0.93	0.75	0.18	1.73	1/8	0.45 + 0.60 per inch of length
106 (1-1/16")	1.12	0.88	0.25	2.15	1/8	0.95 + 0.88 per inch of length
125 (1-1/4")	1.32	1.06	0.25	2.17	1/8	1.19 + 1.22 per inch of length
150 (1-1/2")	1.56	1.25	0.25	2.23	1/8	1.83 + 1.77 per inch of length
200 (2")	2.06	1.75	0.31	2.81	1/4	3.48 + 3.14 per inch of length

Series NCM

Air Tank -X6002 Option

NCME(075 to 200)-Stroke-X6002

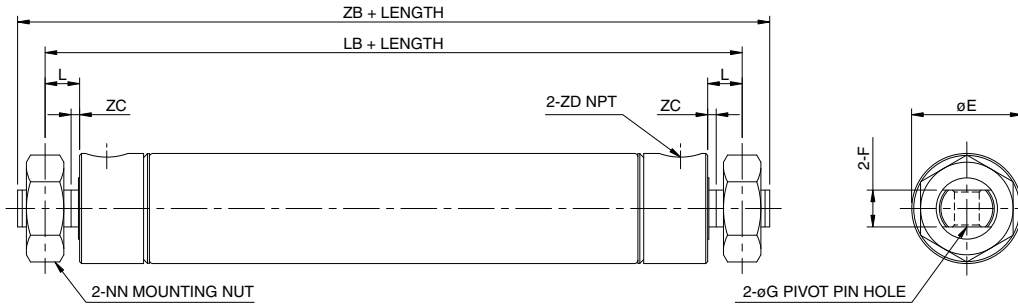

Without Bumper

Bore size (inch)	øE	F	øG	L	LB	NN	ZB	ZC	ZD	Volume (Cubic inches)
075 (3/4")	0.86	0.38	0.251	0.34	3.50	5/8-18	4.06	0.09	1/8	0.68 + 0.44 per inch of length
088 (7/8")	0.93	0.38	0.251	0.34	2.97	5/8-18	3.53	0.09	1/8	0.61 + 0.60 per inch of length
106 (1-1/16")	1.12	0.38	0.251	0.34	3.33	5/8-18	3.89	0.09	1/8	1.08 + 0.88 per inch of length
125 (1-1/4")	1.32	0.50	0.251	0.41	3.64	3/4-16	4.43	0.09	1/8	1.25 + 1.22 per inch of length
150 (1-1/2")	1.56	-	-	0.63	-	3/4-16	3.88	0.09	1/8	1.91 + 1.77 per inch of length
200 (2")	2.06	0.75	0.375	0.56	4.67	1 1/4-12	5.54	0.12	1/4	4.81 + 3.14 per inch of length

Double Acting/Spring Assist -X6005 Option

NCME(075 to 150)- Stroke (C)T-X6005

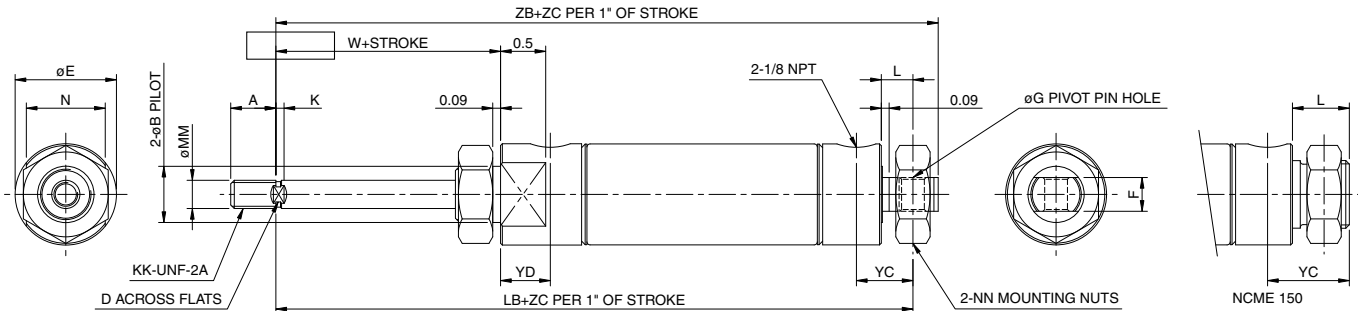

Without Bumper

Bore size (inch)	øMM	KK	A	øB	D	øE	F	G	K	L	LB	N	NN	W	YD	YC	ZB	ZC
075 (3/4")	ø0.250	1/4-28	0.50	ø0.624	-	ø0.86	0.38	0.251	-	0.34	3.81	0.75	5/8-18	0.50	0.45	0.62	4.09	2.69
106 (1-1/16")	ø0.312	5/16-24	0.50	ø0.624	0.25	ø1.12	0.38	0.251	0.12	0.34	3.89	0.88	5/8-18	0.62	0.55	0.62	4.17	2.56
150 (1-1/2")	ø0.437	7/16-20	0.75	ø0.749	0.38	ø1.56	-	-	0.25	0.63	-	1.25	3/4-16	0.88	0.63	0.91	4.56	2.69

Note: For fractions 1/2" go to next highest whole stroke and subtract 1/2".

With Bumper

Bore size (inch)	LB	ZB
075 (3/4")	3.02	4.10
106 (1-1/16")	4.10	4.38
150 (1-1/2")	-	4.76

Double Acting/Spring Assist -X6005 Option



- Double acting with spring

Specifications

Bore size (inch)	075 (3/4")	106 (1-1/16")	150 (1-1/2")
Fluid	Air		
Max. operating pressure	250 PSI / 1.7 MPa		
Min. operating pressure	8 PSI / 0.06 MPa		
Ambient and fluid temp.	40 to 140°F / 5 to 60°C		
Piston speed	No bumper: 2 to 20 in/sec (50 to 500 mm/sec) Bumper: 2 to 30 in/sec (50 to 750 mm/sec)		
Bumper	Optional		
Lubrication	Not required (Pre-lubricated at factory)		
Auto switch capable	Optional		
Mounting	B, C, E		

Standard Stroke

Mounting	Standard stroke (inch)	Max. stroke (inch)
Front nose (B)	1/2, 1, 2, 3, 4, 5, 6	6
Rear pivot (C)		
Double end mount (E)		

How to Order

NC(D)M **Mounting** **Bore** — **Stroke** **Option** — X6005

Ex.) NCDMB075-0400-X6005

NCMB(075 to 150)-Stroke(C)S-X6005

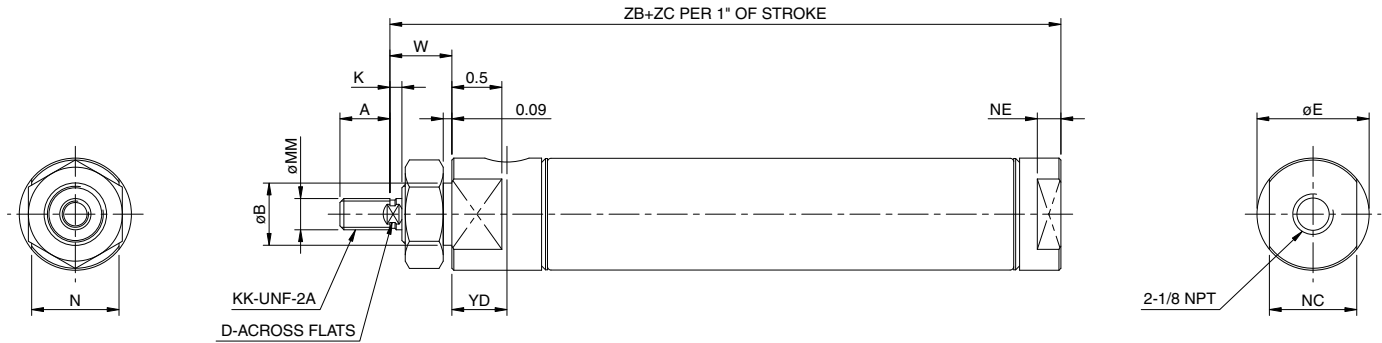

Without Bumper

Bore size (inch)	øMM	KK	A	øB	D	øE	K	N	NC	NE	NN	W	YD	ZB	ZC
075 (3/4")	ø0.250	1/4-28	0.50	ø0.624	—	ø0.86	—	0.75	0.62	0.12	5/8-18	0.50	0.45	3.02	1.69
106 (1-1/16")	ø0.312	5/16-24	0.50	ø0.624	0.25	ø1.12	0.12	0.88	0.88	0.24	5/8-18	0.62	0.55	3.86	1.56
150 (1-1/2")	ø0.437	7/16-20	0.75	ø0.749	0.38	ø1.56	0.25	1.25	1.25	0.25	3/4-16	0.88	0.63	4.42	1.69

Note: For fractions 1/2" go to next highest whole stroke and subtract 1/2".

With Bumper

Bore size (inch)	ZB
075 (3/4")	3.04
106 (1-1/16")	4.08
150 (1-1/2")	4.62

Series NCM

Double Acting/Spring Assist -X6005 Option

NCMB(075 to 150)-Stroke(C)T-X6005

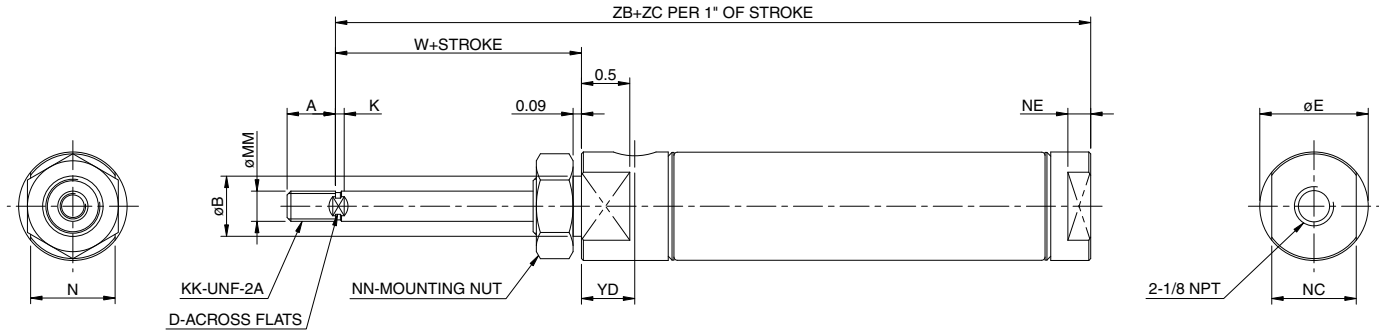

Without Bumper

Bore size (inch)	ØMM	KK	A	ØB	D	ØE	K	N	NC	NE	NN	W	YD	ZB	ZC
075 (3/4")	Ø0.250	1/4-28	0.50	Ø0.624	-	Ø0.86	-	0.75	0.62	0.12	5/8-18	0.50	0.45	3.02	2.69
106 (1-1/16")	Ø0.312	5/16-24	0.50	Ø0.624	0.25	Ø1.12	0.12	0.88	0.88	0.24	5/8-18	0.62	0.55	3.86	2.56
150 (1-1/2")	Ø0.437	7/16-20	0.75	Ø0.749	0.38	Ø1.56	0.25	1.25	1.25	0.25	3/4-16	0.88	0.63	4.42	2.69

With Bumper

Bore size (inch)	ZB
075 (3/4")	3.04
106 (1-1/16")	4.08
150 (1-1/2")	4.62

Note: For fractions 1/2" go to next highest whole stroke and subtract 1/2".

NCMC(075 to 150)-Stroke(C)S-X6005

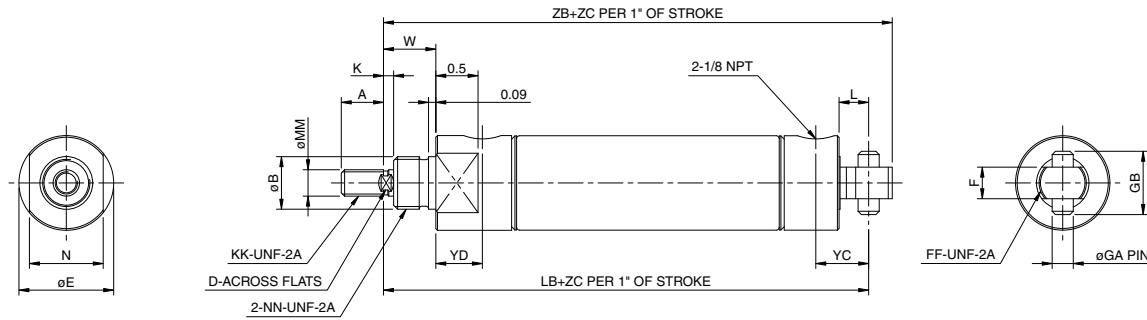

Without Bumper

Bore size (inch)	ØMM	KK	A	ØB	D	ØE	F	FF	GA	GB	K	L	LB	N	NN	W	YD	YC	ZB	ZC
075 (3/4")	Ø0.250	1/4-28	0.50	Ø0.624	-	Ø0.86	0.38	5/8-18	0.250	0.75	-	0.34	3.81	0.75	5/8-18	0.50	0.45	0.62	4.09	1.69
106 (1-1/16")	Ø0.312	5/16-24	0.50	Ø0.624	0.25	Ø1.12	0.38	5/8-18	0.250	0.75	0.12	0.34	3.89	0.88	5/8-18	0.62	0.55	0.62	4.17	1.56
150 (1-1/2")	Ø0.437	7/16-20	0.75	Ø0.749	0.38	Ø1.56	0.62	-	0.375	1.00	0.25	0.50	4.43	1.25	3/4-16	0.88	0.63	0.78	4.81	1.69

Note: For fractions 1/2" go to next highest whole stroke and subtract 1/2".

With Bumper

Bore size (inch)	LB	ZB
075 (3/4")	3.82	4.10
106 (1-1/16")	4.10	4.38
150 (1-1/2")	4.63	5.01

Double Acting/Spring Assist -X6005 Option

NCMC(075 to 150)-Stroke(C)T-X6005

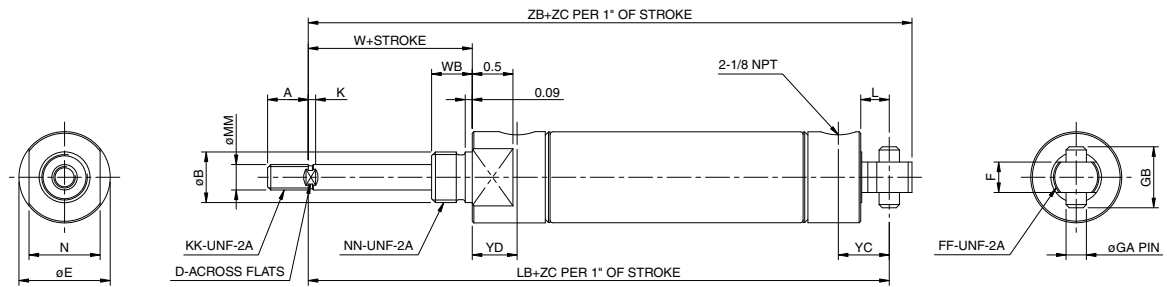

Without Bumper

Bore size (inch)	øMM	KK	A	øB	D	øE	F	FF	GA	GB	K	L	LB	N	NN	W	WB	YD	YC	ZB	ZC
075 (3/4")	ø0.250	1/4-28	0.50	ø0.624	-	ø0.86	0.38	5/8-18	0.250	0.75	-	0.34	3.81	0.75	5/8-18	0.50	0.50	0.45	0.62	4.09	2.69
106 (1-1/16")	ø0.312	5/16-24	0.50	ø0.624	0.25	ø1.12	0.38	5/8-18	0.250	0.75	0.12	0.34	3.89	0.88	5/8-18	0.62	0.50	0.55	0.62	4.17	2.56
150 (1-1/2")	ø0.437	7/16-20	0.75	ø0.749	0.38	ø1.56	0.62	-	0.375	1.00	0.25	0.50	4.43	1.25	3/4-16	0.88	0.62	0.63	0.78	4.81	2.69

Note: For fractions 1/2" go to next highest whole stroke and subtract 1/2".

With Bumper

Bore size (inch)	LB	ZB
075 (3/4")	3.82	4.10
106 (1-1/16")	4.10	4.38
150 (1-1/2")	4.63	5.01

NCME(075 to 150)-Stroke(C)S-X6005

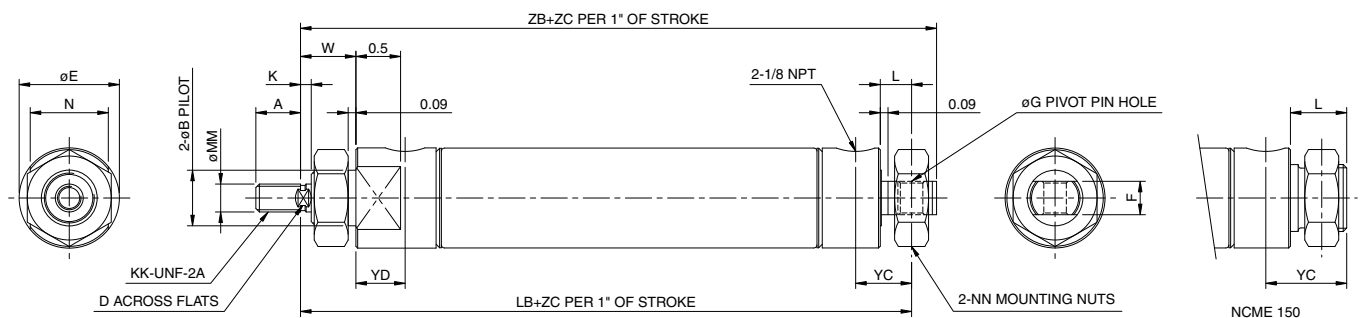

Without Bumper

Bore size (inch)	øMM	KK	A	øB	D	øE	F	G	K	L	LB	N	NN	W	YC	YD	ZB	ZC
075 (3/4")	ø0.250	1/4-28	0.50	ø0.624	-	ø0.86	0.38	0.251	-	0.34	3.81	0.75	5/8-18	0.50	0.62	0.45	4.09	1.69
106 (1-1/16")	ø0.312	5/16-24	0.50	ø0.624	0.25	ø1.12	0.38	0.251	0.12	0.34	3.89	0.88	5/8-18	0.62	0.62	0.55	4.17	1.56
150 (1-1/2")	ø0.437	7/16-20	0.75	ø0.749	0.38	ø1.56	0.62	-	0.25	0.50	-	1.25	3/4-16	0.88	0.91	0.63	4.56	1.69

Note: For fractions 1/2" go to next highest whole stroke and subtract 1/2".

With Bumper

Bore size (inch)	LB	ZB
075 (3/4")	3.82	4.10
106 (1-1/16")	4.10	4.38
150 (1-1/2")	-	4.76

Series NCM

Double Acting/Spring Assist -X6005 Option

NCME(075 to 150)-Stroke(C)T-X6005

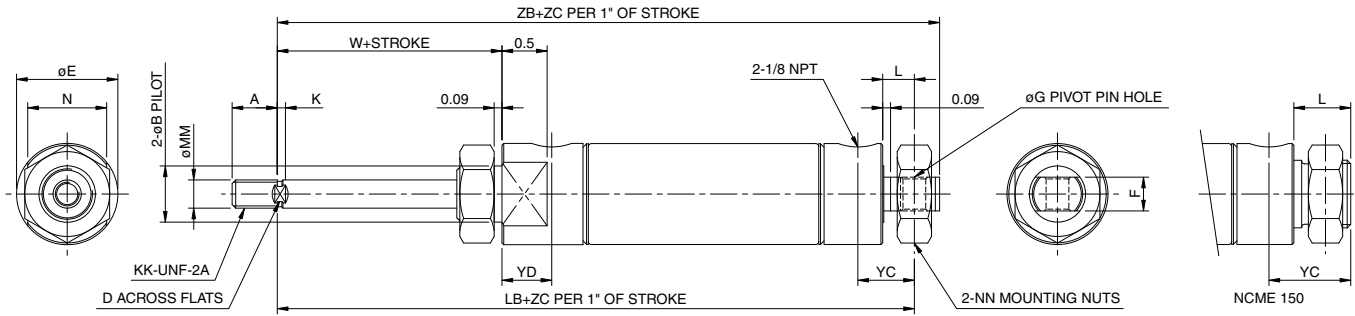

Without Bumper

Bore size (inch)	øMM	KK	A	øB	D	øE	F	G	K	L	LB	N	NN	W	YD	YC	ZB	ZC
075 (3/4")	ø0.250	1/4-28	0.50	ø0.624	—	ø0.86	0.38	0.251	—	0.34	3.81	0.75	5/8-18	0.50	0.45	0.62	4.09	2.69
106 (1-1/16")	ø0.312	5/16-24	0.50	ø0.624	0.25	ø1.12	0.38	0.251	0.12	0.34	3.89	0.88	5/8-18	0.62	0.55	0.62	4.17	2.56
150 (1-1/2")	ø0.437	7/16-20	0.75	ø0.749	0.38	ø1.56	—	—	0.25	0.63	—	1.25	3/4-16	0.88	0.63	0.91	4.56	2.69

Note: For fractions 1/2" go to next highest whole stroke and subtract 1/2".

With Bumper

Bore size (inch)	LB	ZB
075 (3/4")	3.02	4.10
106 (1-1/16")	4.10	4.38
150 (1-1/2")	—	4.76

Accessories

Foot bracket

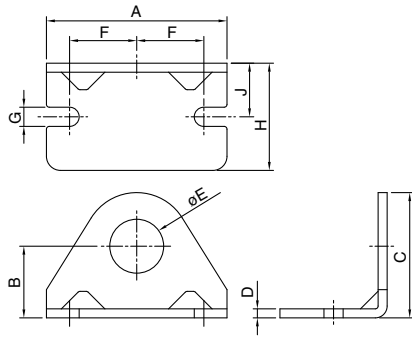

(inch)

Part no.	Applicable bore size	A	B	C	D	E	F	G	H	J
NCM-L044	7/16", 9/16"	1.38	0.56	0.83	0.09	0.44	0.50	0.19	0.69	0.38
NCM-L075*	3/4", 7/8", 1-1/16"	1.89	0.81	1.36	0.12	0.63	0.75	0.27	0.98	0.56
NCM-L150	1-1/4", 1-1/2"	2.52	1.00	1.75	0.12	0.75	0.94	0.27	1.50	0.75
NCMK-L150	1-1/2" (Non-rotating)	2.52	1.00	1.75	0.12	0.88	0.94	0.27	1.50	0.75
NCM-L200	2"	3.126	1.50	2.5	0.25	1.38	1.13	0.34	1.63	1.00

Note) NCM-L075 will not fit NCM*075*S (Single acting). For this option use: NCM075-19-51046.
(E dimension=0.51")

Rod clevis

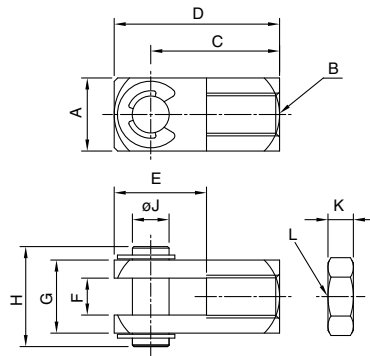

(inch)

Part no.	Applicable bore size	A	B	C	D	E	F	G	H	J	K	L
NY-044	7/16", 9/16"	0.38	No.10-32	0.75	0.94	0.56	0.19	0.38	0.56	0.19	0.12	No.10-32
NY-075	3/4", 7/8"	0.51	1/4-28	0.94	1.18	0.69	0.25	0.51	0.71	0.25	0.16	1/4-28
NY-106	1-1/16"	0.51	5/16-24	0.94	1.18	0.69	0.25	0.51	0.71	0.25	0.19	5/16-24
NY-125	1-1/4", 1-1/2"	0.75	7/16-20	1.31	1.69	0.94	0.38	0.75	1.02	0.38	0.25	7/16-20
NY-G050	2"	0.75	1/2-20	1.32	1.69	0.94	0.38	0.75	1.02	0.38	0.31	1/2-20

Jam nut (Rod thread)

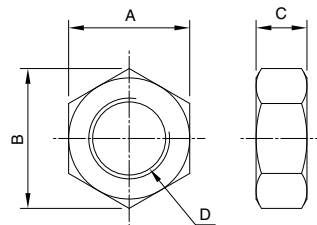

(inch)

Part no.	Applicable bore size	A	B	C	D
JM-02 ^{Note 1)}	7/16", 9/16"	0.38	0.43	0.13	No.10-32 UNF
JM-025	3/4", 7/8"	0.44	0.51	0.16	1/4-28 UNF
JM-03	1-1/16"	0.50	0.50	0.19	5/16-24 UNF
JM-045	1-1/4", 1-1/2"	0.69	0.79	0.26	7/16-20 UNF
JM-04	1-1/4", 1-1/2" (Non-rotating)	0.56	0.65	0.23	3/8-24 UNF
JM-05 ^{Note 1)}	2"	0.75	0.87	0.32	1/2-20 UNF

Note 1) Please order separately. (044, 056, 200 only)

Series NCM

Accessories

Pivot bracket (Rear pivot): NCMC

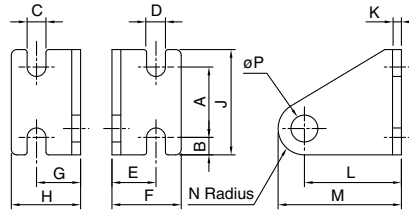

(inch)

Part no.	Applicable bore size	A	B	C	D	E	F	G	H	J	K	L	M	N	øP
NCM-PC044	7/16", 9/16"	0.50	0.12	0.19	0.19	0.28	0.50	0.28	0.50	0.75	0.06	0.56	0.77	0.20	0.16
NCM-PC075	3/4", 7/8", 1-1/16", 1-1/4"	0.75	0.18	0.27	0.27	0.44	0.79	0.44	0.79	1.101	0.12	0.88	1.18	0.31	0.26
NCM-PC150	1-1/2"	1.00	0.25	0.27	0.27	0.62	0.98	0.62	0.98	1.50	0.12	1.38	1.75	0.38	0.38

Pivot bracket (End mount): NCME

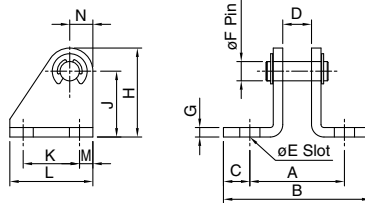

(inch)

Part no.	Applicable bore size	A	B	C	D	øE	F	G	H	J	K	L	M	N
NCM-PE056	9/16"	0.91	1.35	0.22	0.35	0.19	0.16	0.06	0.77	0.56	0.50	0.75	0.12	0.20
NCM-PE075	3/4", 7/8", 1-1/16"	1.25	1.95	0.35	0.38	0.27	0.25	0.12	1.18	0.88	0.75	1.10	0.18	0.31
NCM-PE125	1-1/4"	1.38	2.08	0.35	0.50	0.27	0.25	0.12	1.18	0.88	0.75	1.10	0.18	0.31
NCM-PC050	2"	2.12	3.00	0.44	0.75	0.26	0.38	0.24	1.75	1.38	1.00	1.50	0.25	0.37

Mounting nut (Nose mount thread)

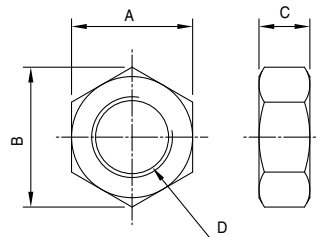

(inch)

Part no.	Applicable bore size	A	B	C	D
JM-045	7/16", 9/16"	0.69	0.79	0.26	7/16-20 UNF
JM-08	3/4", 7/8", 1-1/16"	0.94	1.08	0.38	5/8-18 UNF
JM-10	1-1/4", 1-1/2"	1.12	1.30	0.42	3/4-16 UNF
JM-14	2"	1.61	1.86	0.43	1-1/4 -12 UNF

Auto Switch Proper Mounting Position and Its Mounting Height (Single rod)

D-A9□(V)

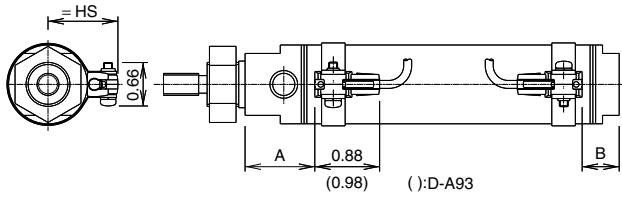

D-M9□(V)/M9□W(V)



D-C7/C8

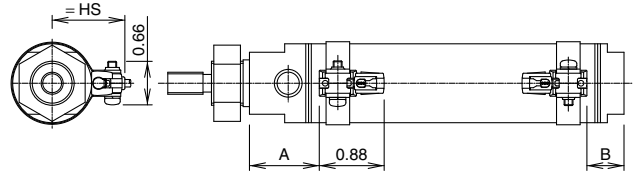
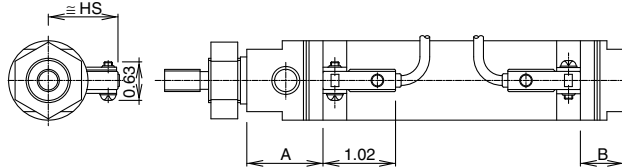

D-B5/B6/B59W

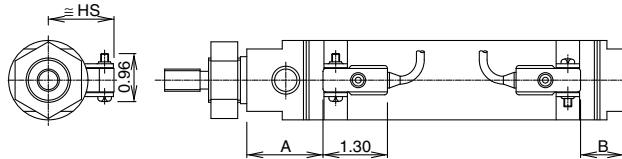

D-H7□/H7□W/H7NF/H7BAL□

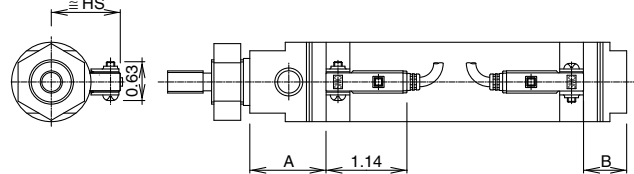

D-C73C/C80C

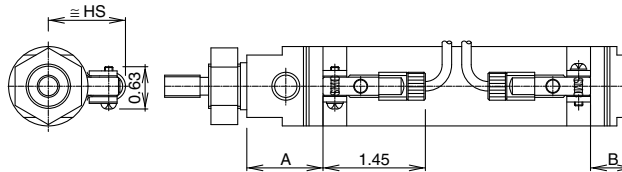

D-G5NTL

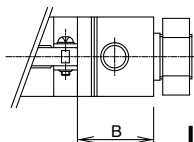
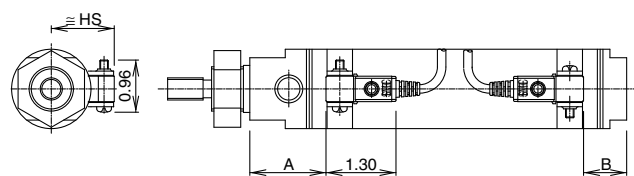

In case of NCDMC, NCDME

D-H7C

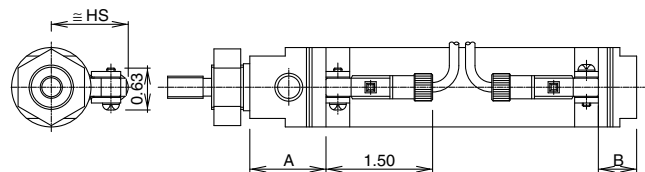

Series NCM

Auto Switch Proper Mounting Position and Its Mounting Height (Single rod)

Auto Switch Mounting Position (NCDMB) (in)

Auto switch model	D-M9□ D-M9□W		D-A9□		D-H7□ D-H7□W D-H7C D-H7BAL D-H7NF		D-C7□ D-C80 D-C73C D-C80C		D-G5NTL		D-B5□ D-B64		D-B59W	
	A	B	A	B	A	B	A	B	A	B	A	B	A	B
044 (7/16")	1.4	0.52	1.24	0.36	1.22	0.34	1.26	0.38	-	-	-	-	-	-
056 (9/16")	1.21	0.54	1.05	0.38	1.03	0.36	1.07	0.4	-	-	-	-	-	-
075 (3/4")	1.25	0.73	1.10	0.58	1.08	0.56	1.12	0.60	0.94	0.42	0.88	0.37	1.00	0.48
088 (7/8")	1.09	0.62	0.94	0.46	0.92	0.45	0.96	0.49	0.78	0.31	0.72	0.25	0.84	0.37
106 (1-1/16")	1.31	0.83	1.16	0.68	1.14	0.66	1.18	0.70	1.00	0.52	0.94	0.46	1.06	0.58
125 (1-1/4")	1.54	0.82	1.39	0.67	1.37	0.65	1.41	0.69	1.23	0.51	1.17	0.46	1.29	0.57
150 (1-1/2")	1.44	0.87	1.29	0.71	1.27	0.70	1.31	0.74	1.13	0.56	1.07	0.5	1.19	0.61
200 (2")	1.89	1.14	1.74	0.98	1.72	0.97	1.75	1.01	1.58	0.83	1.52	0.77	1.63	0.88

Auto Switch Mounting Position (NCDMB-*C) (in)

Auto switch model	D-M9□ D-M9□W		D-A9□		D-H7□ D-H7□W D-H7C D-H7BAL D-H7NF		D-C7□ D-C80 D-C73C D-C80C		D-G5NTL		D-B5□ D-B64		D-B59W	
	A	B	A	B	A	B	A	B	A	B	A	B	A	B
044 (7/16")	1.4	0.55	1.24	0.39	1.22	0.37	1.06	0.41	-	-	-	-	-	-
056 (9/16")	1.21	0.56	1.05	0.4	1.03	0.38	1.07	0.42	-	-	-	-	-	-
075 (3/4")	1.29	0.71	1.13	0.56	1.12	0.54	1.16	0.58	0.98	0.4	0.92	0.35	1.03	0.46
088 (7/8")	1.22	0.75	1.06	0.59	1.05	0.58	1.09	0.62	0.91	0.44	0.85	0.38	0.97	0.5
106 (1-1/16")	1.38	0.90	1.23	0.75	1.27	0.79	1.31	0.83	1.13	0.65	1.07	0.59	1.19	0.71
125 (1-1/4")	1.67	0.95	1.51	0.80	1.50	0.78	1.54	0.82	1.36	0.64	1.30	0.59	1.42	0.7
150 (1-1/2")	1.51	0.94	1.36	0.78	1.40	0.83	1.44	0.87	1.26	0.69	1.20	0.63	1.32	0.74
200 (2")	2.02	1.27	1.86	1.11	1.85	1.10	1.88	1.14	1.71	0.96	1.65	0.90	1.76	1.01

Auto Switch Mounting Position (NCDMC, NCDME) (in)

Auto switch model	D-M9□ D-M9□W		D-A9□		D-H7□ D-H7□W D-H7C D-H7BAL D-H7NF		D-C7□ D-C80 D-C73C D-C80C		D-G5NTL		D-B5□ D-B64		D-B59W	
	A	B	A	B	A	B	A	B	A	B	A	B	A	B
044 (7/16")	1.4	1.21	1.24	1.05	1.22	1.03	1.26	1.07	-	-	-	-	-	-
056 (9/16")	1.21	1.1	1.05	0.44	1.03	0.97	1.07	0.96	-	-	-	-	-	-
075 (3/4")	1.25	1.17	1.10	1.02	1.08	1.00	1.12	1.03	0.94	0.86	0.88	0.8	1.00	0.91
088 (7/8")	1.09	0.90	0.94	0.75	0.92	0.72	0.96	0.76	0.78	0.59	0.72	0.53	0.84	0.64
106 (1-1/16")	1.31	1.07	1.16	0.92	1.14	0.90	1.18	0.94	1.00	0.76	0.94	0.7	1.06	0.81
125 (1-1/4")	1.54	1.16	1.39	1.01	1.37	0.98	1.41	1.02	1.23	0.85	1.17	0.79	1.29	0.90
150 (1-1/2")	1.44	1.07	1.29	0.92	1.27	0.89	1.31	0.93	1.13	0.75	1.07	0.7	1.19	0.81
200 (2")	1.89	1.51	1.74	1.36	1.72	1.34	1.75	1.38	1.58	1.20	1.52	1.14	1.63	1.25

Auto Switch Mounting Position (NCDMC-*C, NCDME-*C) (in)

Auto switch model	D-M9□ D-M9□W		D-A9□		D-H7□ D-H7□W D-H7C D-H7BAL D-H7NF		D-C7□ D-C80 D-C73C D-C80C		D-G5NTL		D-B5□ D-B64		D-B59W	
	A	B	A	B	A	B	A	B	A	B	A	B	A	B
044 (7/16")	1.4	1.24	1.24	1.08	1.22	1.06	1.26	1.1	-	-	-	-	-	-
056 (9/16")	1.21	1.12	1.05	0.96	1.03	0.94	1.07	0.98	-	-	-	-	-	-
075 (3/4")	1.29	1.15	1.13	1.00	1.12	0.98	1.16	1.01	0.98	0.84	0.92	0.78	1.03	0.89
088 (7/8")	1.22	1.03	1.06	0.88	1.05	0.85	1.09	0.89	0.91	0.72	0.85	0.66	0.97	0.77
106 (1-1/16")	1.38	1.20	1.23	1.05	1.27	1.03	1.31	1.07	1.13	0.89	1.07	0.83	1.19	0.94
125 (1-1/4")	1.67	1.29	1.51	1.14	1.50	1.11	1.54	1.15	1.36	0.98	1.30	0.92	1.42	1.03
150 (1-1/2")	1.51	1.20	1.36	1.05	1.40	1.02	1.44	1.06	1.26	0.88	1.20	0.83	1.32	0.94
200 (2")	2.02	1.64	1.86	1.49	1.85	1.47	1.88	1.51	1.71	1.33	1.65	1.27	1.76	1.38

Mounting Height (NCDM) (in)

Auto switch model	D-M9□ D-M9□W D-A9□ D-A9□V		D-M9□V D-M9□WV D-H7□ D-H7□W D-H7BAL D-H7NF D-C7□ D-C80		D-H7C	D-C73C D-C80C	D-G5NTL D-B5□ D-B59W D-B64
	≒HS	≒HS	≒HS	≒HS	≒HS	≒HS	≒HS
044 (7/16")	0.7	0.72	0.83	0.81	-	-	-
056 (9/16")	0.77	0.79	0.9	0.88	-	-	-
075 (3/4")	0.85	0.87	0.98	0.96	0.98	-	-
088 (7/8")	0.91	0.93	1.04	1.02	1.04	-	-
106 (1-1/16")	0.96	0.98	1.14	1.12	1.14	-	-
125 (1-1/4")	1.06	1.08	1.24	1.22	1.24	-	-
150 (1-1/2")	1.18	1.20	1.36	1.34	1.36	-	-
200 (2")	1.44	1.46	1.61	1.59	1.61	-	-

Note 1) D-G5NTL, B5□, B64, B59W cannot be mounted on models with bore size 044 and 056.
 Note 2) When setting an auto switch, confirm the operation and adjust its mounting position.

Auto Switch Proper Mounting Position and Its Mounting Height (Double rod)

D-A9□(V)

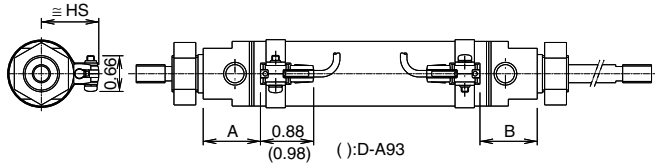

D-M9□(V)/M9□W(V)

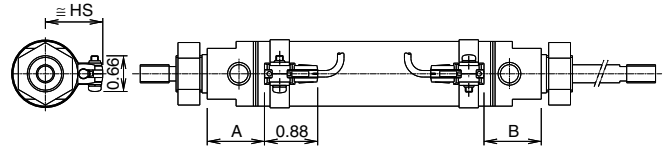

D-C7/C8

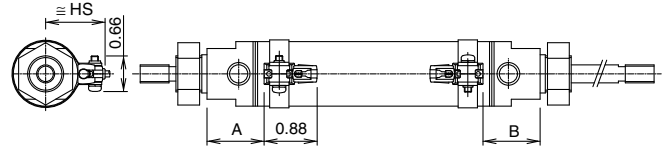
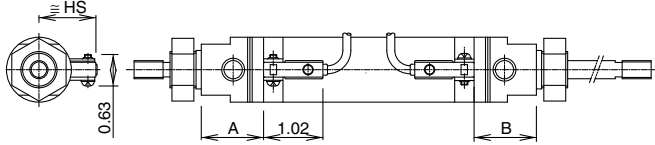

D-B5/B6/B59W

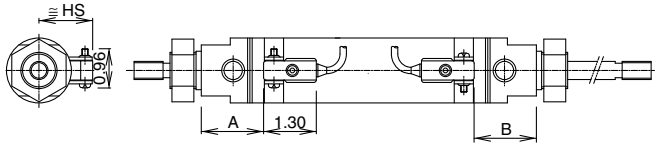

D-H7□/H7□W/H7NF/H7BAL□

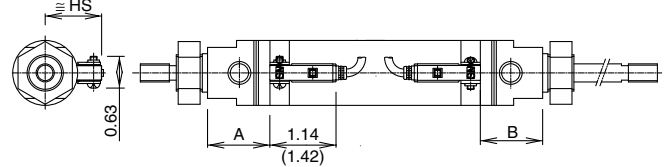

D-C73C/C80C

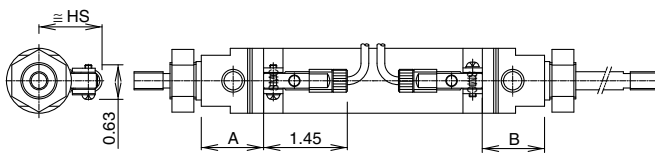

D-G5NTL

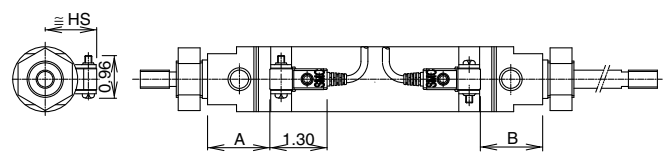

Auto Switch Mounting Position (NCDMW) (in)

Auto switch model	D-M9□ D-M9□W		D-A9□		D-H7□ D-H7□W D-H7C D-H7BAL D-H7NF		D-C7□ D-C80 D-C73C D-C80C		D-G5NTL		D-B5□ D-B64		D-B59W	
	A	B	A	B	A	B	A	B	A	B	A	B	A	B
075 (3/4")	1.25	1.26	1.10	1.11	1.08	1.09	1.12	1.13	0.94	0.95	0.88	0.89	1.00	1.00
088 (7/8")	1.09	1.09	0.94	0.94	0.92	0.91	0.96	0.95	0.78	0.77	0.72	0.72	0.84	0.83
106 (1-1/16")	1.31	1.32	1.16	1.17	1.14	1.14	1.18	1.18	1.00	1.01	0.94	0.95	1.06	1.06
125 (1-1/4")	1.54	1.51	1.39	1.36	1.37	1.34	1.41	1.38	1.23	1.20	1.17	1.14	1.29	1.26
150 (1-1/2")	1.44	1.44	1.29	1.29	1.27	1.27	1.31	1.31	1.13	1.13	1.07	1.07	1.19	1.18
200 (2")	1.89	1.82	1.74	1.67	1.72	1.65	1.75	1.69	1.58	1.51	1.52	1.45	1.63	1.57

D-H7C

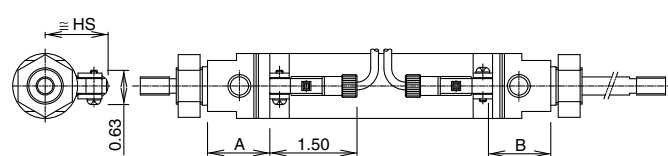

Auto Switch Mounting Position (NCDMW-*C) (in)

Auto switch model	D-M9□ D-M9□W		D-A9□		D-H7□ D-H7□W D-H7C D-H7BAL D-H7NF		D-C7□ D-C80 D-C73C D-C80C		D-G5NTL		D-B5□ D-B64		D-B59W	
	A	B	A	B	A	B	A	B	A	B	A	B	A	B
075 (3/4")	1.29	1.24	1.14	1.09	1.12	1.07	1.16	1.11	0.98	0.93	0.92	0.87	1.03	0.98
088 (7/8")	1.22	1.22	1.07	1.07	1.05	1.04	1.09	1.08	0.91	0.9	0.85	0.85	0.97	0.96
106 (1-1/16")	1.38	1.39	1.23	1.23	1.21	1.21	1.25	1.25	1.07	1.07	1.01	1.01	1.12	1.13
125 (1-1/4")	1.67	1.64	1.52	1.49	1.50	1.47	1.54	1.51	1.36	1.33	1.30	1.27	1.42	1.39
150 (1-1/2")	1.51	1.51	1.36	1.35	1.34	1.33	1.38	1.37	1.20	1.19	1.14	1.14	1.25	1.25
200 (2")	2.02	1.95	1.87	1.80	1.85	1.78	1.88	1.82	1.71	1.64	1.65	1.58	1.76	1.7

Mounting Height (NCDMW) (in)

Auto switch model	D-M9□ D-M9□W D-A9□ D-A9□V		D-M9□V D-M9□WV D-H7□ D-H7□W D-H7BAL D-H7NF D-C7□ D-C80		D-H7C	D-C73C D-C80C	D-G5NTL D-B5□ D-B59W D-B64
	≅HS	≅HS	≅HS	≅HS	≅HS	≅HS	≅HS
075 (3/4")	0.85	0.87	0.98	0.96	0.98	0.96	0.98
088 (7/8")	0.91	0.93	1.04	1.02	1.04	1.02	1.04
106 (1-1/16")	0.96	0.98	1.14	1.12	1.14	1.12	1.14
125 (1-1/4")	1.06	1.08	1.24	1.22	1.24	1.22	1.24
150 (1-1/2")	1.18	1.20	1.36	1.34	1.36	1.34	1.36
200 (2")	1.44	1.46	1.61	1.59	1.61	1.59	1.61

Note 1) D-G5NTL, B5□, B64, B59W cannot be mounted on models with bore size 044 and 056.
 Note 2) When setting an auto switch, confirm the operation and adjust its mounting position.

Series NCM

Auto Switch Proper Mounting Position and Its Mounting Height (Block mount)

D-A9□(V)

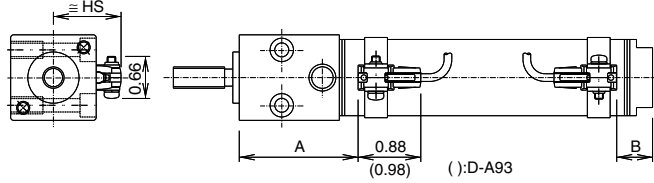

D-M9□(V)/M9□W(V)

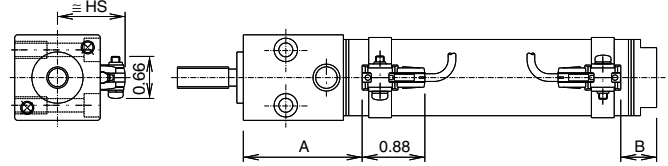

D-C7/C8

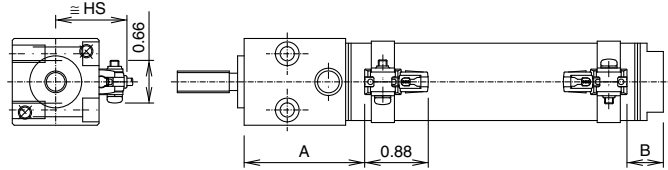
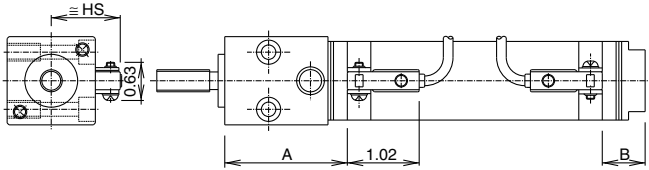

D-B5/B6/B59W

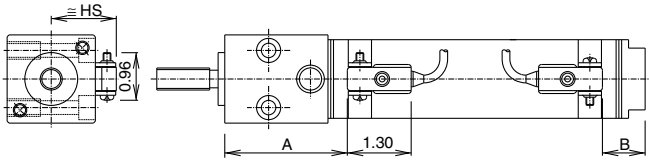

D-H7□/H7□W/H7NF/H7BAL□

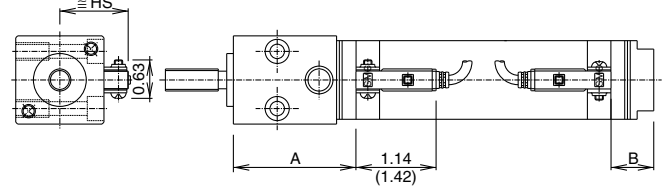

D-C73C/C80C

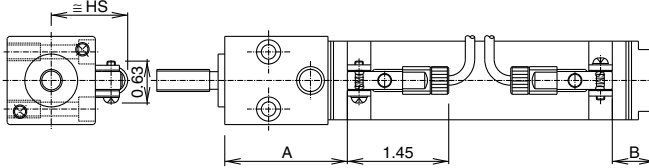

D-G5NTL

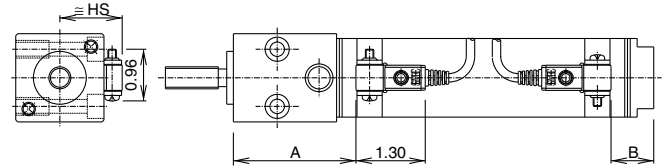

D-H7C

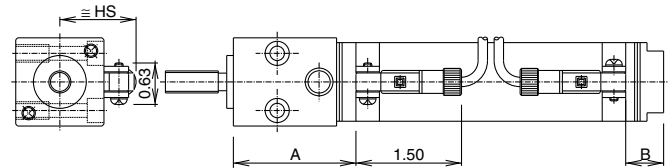

Auto Switch Mounting Position (NCDMR) (in)

Auto switch model	D-M9□ D-M9□W		D-A9□		D-H7□ D-H7□W D-H7C D-H7BAL D-H7NF		D-C7□ D-C80 D-C73C D-C80C		D-G5NTL		D-B5□ D-B64		D-B59W	
	A	B	A	B	A	B	A	B	A	B	A	B	A	B
075 (3/4")	1.67	0.74	1.52	0.59	1.50	0.56	1.54	0.60	1.36	0.42	1.30	0.37	1.42	0.48
106 (1-1/16")	1.98	0.83	1.83	0.68	1.81	0.66	1.85	0.70	1.67	0.52	1.61	0.46	1.72	0.58
150 (1-1/2")	2.47	0.87	2.32	0.72	2.29	0.70	2.33	0.74	2.16	0.56	2.10	0.50	2.21	0.61

Auto Switch Mounting Position (NCDMR-*C) (in)

Auto switch model	D-M9□ D-M9□W		D-A9□		D-H7□ D-H7□W D-H7C D-H7BAL D-H7NF		D-C7□ D-C80 D-C73C D-C80C		D-G5NTL		D-B5□ D-B64		D-B59W	
	A	B	A	B	A	B	A	B	A	B	A	B	A	B
075 (3/4")	1.67	0.74	1.52	0.59	1.50	0.56	1.54	0.60	1.36	0.42	1.30	0.37	1.42	0.48
106 (1-1/16")	1.98	0.83	1.83	0.68	1.81	0.66	1.85	0.70	1.67	0.52	1.61	0.46	1.72	0.58
150 (1-1/2")	2.47	0.87	2.32	0.72	2.29	0.70	2.33	0.74	2.16	0.56	2.10	0.50	2.21	0.61

Mounting Height (NCDMR and NCDMR-*C) (in)

Auto switch model	D-M9□ D-M9□W D-A9□ D-A9□V		D-M9□V D-M9□WV D-H7□ D-H7□W D-H7BAL D-H7NF D-C7□ D-C80		D-C73C D-C80C		D-G5NTL D-B5□ D-B59W D-B64	
	≅HS	≅HS	≅HS	≅HS	≅HS	≅HS	≅HS	≅HS
088 (7/8")	0.91	0.93	1.02	1.04				
106 (1-1/16")	0.96	0.98	1.12	1.14				
150 (1-1/2")	1.06	1.08	1.22	1.24				

Note 1) D-G5NTL, B5□, B64, B59W cannot be mounted on models with bore size 044 and 056.

Note 2) When setting an auto switch, confirm the operation and adjust its mounting position.

Minimum Stroke for Auto Switch Mounting

(in)

Auto switch model	Number of switches				1
	2		n		
	On different surfaces	On the same surface	On different surfaces	On the same surface	
D-M9□ D-M9□W D-A9□	0.6	Note 2) 1.8	$0.6 + 1.8 \frac{(n-2)}{2}$ (n = 2, 4, 6...)	$1.8 + 1.8 (n-2)$ (n = 2, 4, 6...)	0.4
D-M9□V D-M9□WV D-A9□V	0.6	1.4	$0.6 + 1.2 \frac{(n-2)}{2}$ (n = 2, 4, 6...)	$1.4 + 1.2 (n-2)$ (n = 2, 4, 6...)	0.4
D-H7□ D-H7□W D-H7BAL D-H7NF	0.6	2.3	$0.6 + 1.8 \frac{(n-2)}{2}$ (n = 2, 4, 6...)	$2.3 + 1.8 (n-2)$ (n = 2, 4, 6...)	0.4
D-C7□ D-C80	0.6	2.3	$0.6 + 1.8 \frac{(n-2)}{2}$ (n = 2, 4, 6...)	$2.3 + 1.8 (n-2)$ (n = 2, 4, 6...)	0.4
D-H7C D-C73C D-C80C	0.6	3.1	$0.6 + 2 \frac{(n-2)}{2}$ (n = 2, 4, 6...)	$3.1 + 2 (n-2)$ (n = 2, 4, 6...)	0.4
D-G5NTL	0.6	2.8	$0.6 + 2 \frac{(n-2)}{2}$ (n = 2, 4, 6...)	$2.8 + 2 (n-2)$ (n = 2, 4, 6...)	0.4
D-B5□ D-B64	0.6	2.7	$0.6 + 2 \frac{(n-2)}{2}$ (n = 2, 4, 6...)	$2.7 + 2.2 (n-2)$ (n = 2, 4, 6...)	0.4
D-B59W	0.8	2.9	$0.8 + 2 \frac{(n-2)}{2}$ (n = 2, 4, 6...)	$2.9 + 2.2 (n-2)$ (n = 2, 4, 6...)	0.6

Note 1) D-G5NTL, B5□, B64, B59W cannot be mounted on models with bore size 044 and 056.

Note 2) When two D-M9□, M9□W, or A93 type auto switches are mounted on models with bore size 044.

(in)

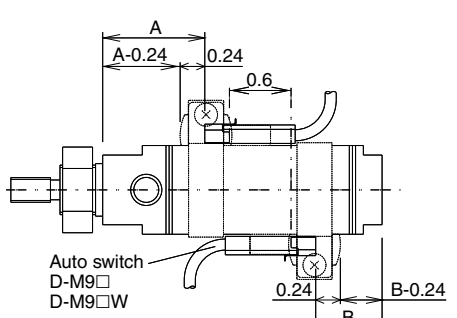
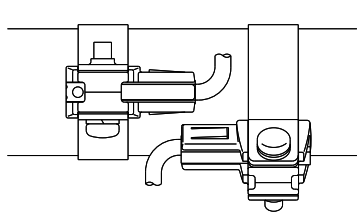
Auto switch model	With 2 auto switches	
	On different surfaces	On the same surface
	 <p>The proper mounting position is 0.24" inward from the end face of the switch holder.</p>	 <p>The switches are mounted in staggered positions in a direction (toward the outer circumference of the cylinder tube) in which the switches and lead wires will not interfere with one another.</p>
D-M9□ D-M9□W	Less than 0.8" stroke	Less than 2" stroke
D-A93	-	

Series NCM

Auto Switch Mounting

Auto Switch Model	Bore Size							
	044	056	075	088	106	125	150	200
D-M9□(V)	Note A) ①BJ2-012 ④BJ3-1	Note A) ①BJ2-015 ④BJ3-1	②NBM3-075	②NBM3-088	②NBM3-106	②BM7-032	②NBM3-150	②NBM3-200
D-M9□W(V)			Note C) ③NBM3-075S	Note C) ③NBM3-088S	Note C) ③NBM3-106S	Note C) ③BM7-032S	Note C) ③NBM3-150S	Note C) ③NBM3-200S
D-A9□(V)								
D-M9□A(V)								
D-H7□	①BJ2-012	①BJ2-015	①NBM2-075A	①NBM2-088A	①NBM2-106A	①NBM2-125A	①NBM2-150A	①NBM2-200A
D-H7□W			Note C) ①NBM2-075AS	Note C) ①NBM2-088AS	Note C) ①NBM2-106AS	Note C) ①NBM2-125AS	Note C) ①NBM2-150AS	Note C) ①NBM2-200AS
D-H7NF								
D-C7□/80								
D-C73C/80C								
D-H7BAL	-	-	NBA-075	NBA-088	NBA-106	NBA-125	NBA-150	NCMA-200
D-G5NTL								
D-B5□/ B59W/ B64								

Note A) Two types of auto switch mounting brackets are used as a set.

Note B) D-G5NTL, B5□, B64, B59W cannot be mounted on models with bore size 044 and 056.

Note C) The "S" in the part number for NBM2-□□□S and NBM3-□□□S indicates mounting band and screw are stainless steel.

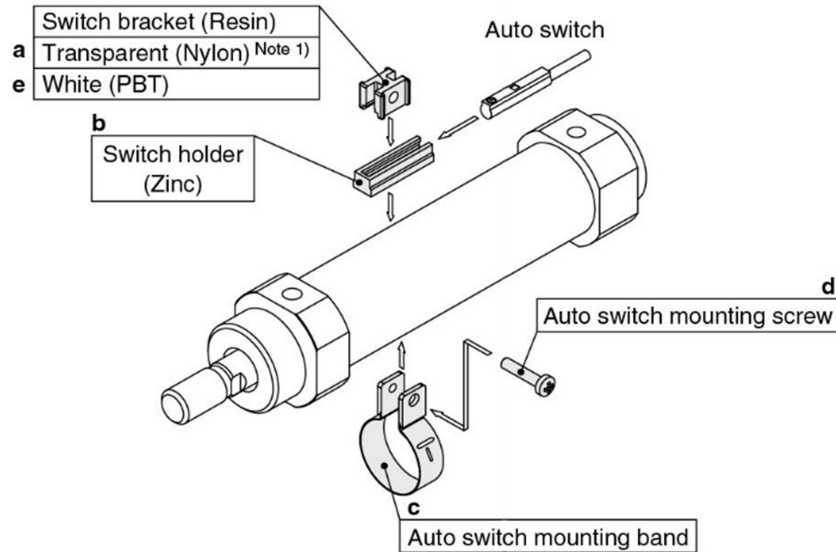

- ① A set of the parts marked "c" and "d" in the diagram are within part numbers BJ2-□□□, NBM2-□□□A, and NBM2-□□□AS.
- ② A set of the parts marked "a", "b", "c", and "d" in the diagram are within part numbers NBM3-□□□ and BM7-032.
- ③ A set of the parts marked "a", "b", "c", and "e" in the diagram are within part numbers NBM3-□□□S and BM7-032S.
- ④ BJ3-1 contains a switch bracket, switch holder, and switch spacer (not shown in diagram).

Stainless steel screw set

The set of stainless steel mounting screws described below is available and can be used depending on the operating environment. As auto switch bracket is not included, order separately.

Detailed Contents of Stainless Steel Mounting Screw Sets

Part no.	Content			Applicable auto switch mounting bracket part no.	Applicable auto switch
	Description	Size	Qty.		
BBA3	Auto switch mounting screw	M4X0.7X22L	1	NBA-075/088/106/125/150 NCMA-200	D-G5NTL D-B5□□ D-B64
BBA4	Auto switch mounting screw	M3X0.5X14L	1	BJ2-012/015 NBM2-075/088/106/125/150*AS NCMB-200AS	D-H7□□ D-C7□□ D-C80□

D-H7BAL switch is set on the cylinder with the stainless steel screws (BBA4) above when shipped. When only a switch is shipped independently, BBA4 screws are attached.

Operating Range

Auto switch model	Bore size (inch)							
	044	056	075	088	106	125	150	200
M9□(V)/D-M9□W(V)	0.12	0.12	0.12	0.12	0.12	0.12	0.14	0.14
D-A9□(V)	0.22	0.22	0.26	0.28	0.26	0.3	0.3	0.3
D-H7□/H7□W/H7NF/H7BAL	0.16	0.16	0.18	0.2	0.18	0.2	0.22	0.22
D-H7C	0.16	0.16	0.18	0.2	0.18	0.2	0.22	0.22
D-C7□/C80/C73C/C80C	0.3	0.3	0.34	0.36	0.32	0.34	0.38	0.38
D-G5NTL	–	–	0.18	0.18	0.18	0.2	0.22	0.22
D-B5□/B64	–	–	0.4	0.42	0.38	0.42	0.46	0.46
D-B59W	–	–	0.56	0.56	0.54	0.56	0.6	0.6

Note 1) Since this is a guideline including hysteresis, not meant to be guaranteed.

(Assuming approximately ±30% dispersion)

There may be the case it will vary substantially depending on an ambient environment.

Note 2) D-G5NTL, B5□, B64, B59W cannot be mounted on models with bore size 044 and 056.

Other than the models listed “How to Order,” the following auto switches are applicable.

Auto switch type	Model	Electrical entry (Entry direction)	Special function	Applicable bore size	
Solid state switch	D-M9NV, M9PV, M9BV D-H7A1, H7A2, H7B	Grommet (In-line)	–	044 to 200	
	D-M9NWV, M9PWV, M9BWV D-H7NW, H7PW, H7BW		Diagnostic indication (2-color indication)		
	D-G5NTL		With timer	075 to 200	
Reed switch	D-B53		Grommet (In-line)	–	044 to 200
	D-A93V, A96V D-C73, C76			–	
	D-A90V			None	044 to 200
	D-C80				

* Solid state switches with pre-wired connector are also available. For details, refer to Best Pneumatics catalog.

Auto Switch Specifications

Auto Switch Common Specifications

Type	Reed switch	Solid state switch
Leakage current	None	3-wire: 100 μ A or less 2-wire: 0.8 mA or less
Operating time	1.2 ms	1 ms or less
Impact resistance	300 m/s ²	1000 m/s ²
Insulation resistance	50 M Ω or more at 500 VDC Mega (between lead wire and case)	
Withstand voltage	1500 VAC for 1 minute (between lead wire and case) ^{Note)}	1000 VAC for 1 minute (between lead wire and case)
Ambient temperature	-10 to 60°C	
Enclosure	IEC60529 standard IP67	
Standard	Conforming to CE	

Note) D-C73C/C80C type: 1000 VAC/min. (Between lead wire and case)

Lead Wire

Lead wire length indication

(Example) **D-M9BW** **L**

Lead wire length

Nil	0.5 m
M	1 m
L	3 m
Z	5 m

Note 1) Applicable auto switch with 5 m lead wire "Z"
Solid state switch: Manufactured upon receipt of order as standard.

Note 2) 1 m (M): D-M9□□ only.

Note 3) Lead wire tolerance

Lead wire length	Tolerance
0.5 m	±15 mm
1 m	±30 mm
3 m	±90 mm
5 m	±150 mm

Solid state switch with oilproof flexible heavy-duty vinyl cord indication

To designate solid state switches with flexible specifications, add "-61" after the lead wire length. Flexible cable is used for D-M9□, D-M9□W as standard. There is no need to place the suffix -61 at the end of the part number.

(Example) **D-H7BAL-61**

Flexible specification

Lead wires with connector indication

Part No. of Lead Wires with Connectors

Model	Lead wire length	(Applicable for connector type only)
D-LC05	0.5 m	
D-LC30	3 m	
D-LC50	5 m	

Contact Protection Boxes: CD-P11, CD-P12

<Applicable switch model>

D-A9/A9□V/C7/C80/C73C/C80C type

The auto switches below do not have a built-in contact protection circuit. A contact protection box is not required for solid state switches due to their construction.

Therefore, please use a contact protection box with the switch for any of the following cases:

- Where the operation load is an inductive load.
- Where the wiring length to the load is greater than 5 m.
- Where the load voltage is 100 VAC.

The contact life may be shortened (due to permanent energizing conditions).

Where the load voltage is 110 VAC.

Where the load voltage is increased by 10% of the rated voltage for the above applicable auto switch model (except for D-C73C, C80C), you can use the auto switches at a load voltage of 110 VAC by using a contact protection box (CD-P11) and setting the load current within the current range in which the maximum load current is decreased by 10%.

Specifications

Part no.	CD-P11		CD-P12
Load voltage	100 VAC	200 VAC	24 VDC
Max. load current	25 mA	12.5 mA	50 mA

* Lead wire length — Switch connection side 0.5 m
Load connection side 0.5 m



Internal Circuit

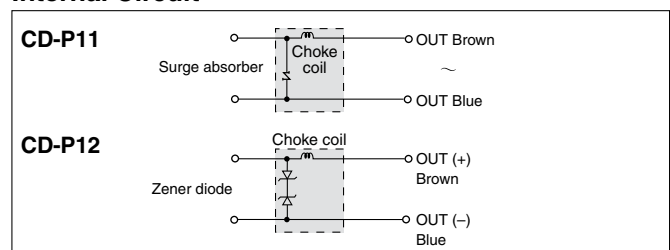

Dimensions

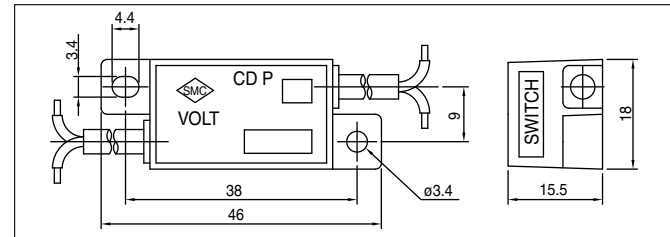

Connection

To connect a switch unit to a contact protection box, connect the lead wire from the side of the contact protection box marked SWITCH to the lead wire coming out of the switch unit. Keep the switch as close as possible to the contact protection box, with a lead wire length of no more than 1 meter.

Auto Switch Connections and Examples

Basic Wiring

Solid state 3-wire, NPN

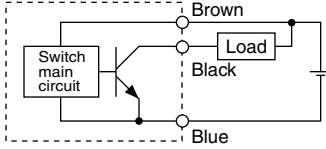

Solid state 3-wire, PNP

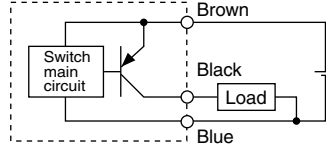

2-wire (Solid state)

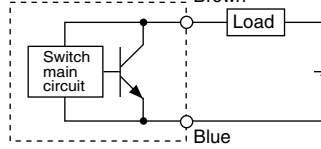

2-wire (Reed)

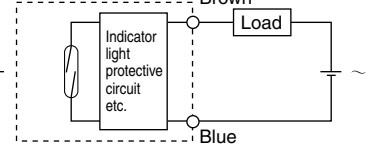

(Power supplies for switch and load are separate.)

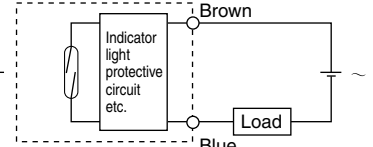
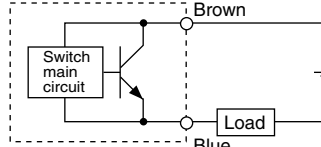
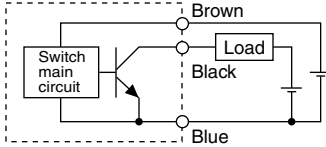

Example of Connection to PLC (Programmable Logic Controller)

• Sink input specification 3-wire, NPN

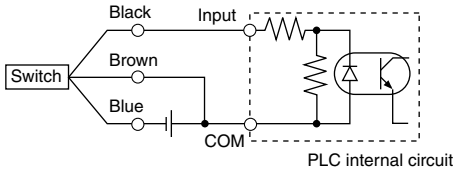

• Source input specification 3-wire, PNP

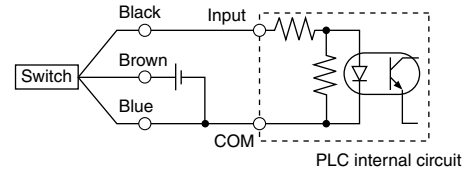

Connect according to the applicable PLC input specifications, since the connection method will vary depending on the PLC input specifications.

2-wire

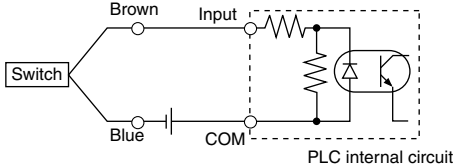

2-wire

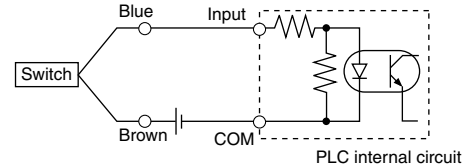

Example of AND (Serial) and OR (Parallel) Connection

• 3-wire

AND connection for NPN output (using relays)

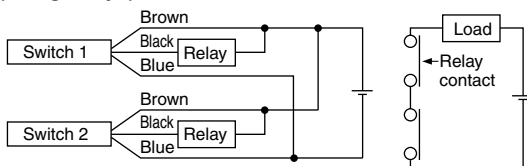

AND connection for NPN output (performed with switches only)

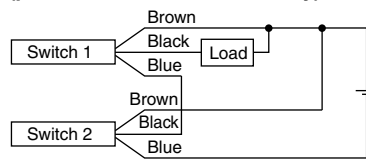

OR connection for NPN output

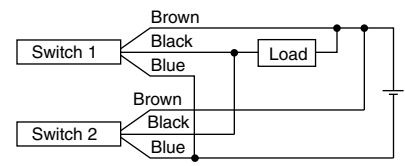

The indicator lights will illuminate when both switches are turned ON.

2-wire with 2-switch AND connection

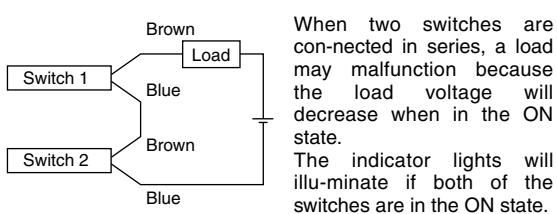

When two switches are connected in series, a load may malfunction because the load voltage will decrease when in the ON state. The indicator lights will illuminate if both of the switches are in the ON state.

$$\begin{aligned} \text{Load voltage at ON} &= \text{Power supply voltage} - \text{Residual voltage} \times 2 \text{ pcs.} \\ &= 24 \text{ V} - 4 \text{ V} \times 2 \text{ pcs.} \\ &= 16 \text{ V} \end{aligned}$$

Example: Power supply is 24 VDC.
Internal voltage drop in switch is 4 V.

2-wire with 2-switch OR connection

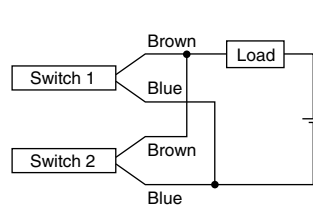

(Solid state)

When two switches are connected in parallel, a malfunction may occur because the load voltage will increase when in the OFF state.

$$\begin{aligned} \text{Load voltage at OFF} &= \text{Leakage current} \times 2 \text{ pcs.} \\ &\quad \times \text{Load impedance} \\ &= 1 \text{ mA} \times 2 \text{ pcs.} \times 3 \text{ k}\Omega \\ &= 6 \text{ V} \end{aligned}$$

Example: Load impedance is 3 kΩ.
Leakage current from switch is 1 mA.

(Reed)

Because there is no current leakage, the load voltage will not increase when turned OFF. However, depending on the number of switches in the ON state, the indicator lights may sometimes dim or not light because of the dispersion and reduction of the current flowing to the switches.

Solid State Switch: Direct Mounting Style

D-M9N(V)/D-M9P(V)/D-M9B(V)

Grommet

- 2-wire load current is reduced (2.5 to 40 mA).
- Flexibility is 1.5 times greater than the conventional model (SMC comparison).
- Using flexible cable as standard spec.



Caution

Precautions

Fix the switch with appropriate screw installed on the switch body. If using other screws, the switch may be damaged.

Auto Switch Internal Circuit

D-M9N(V)

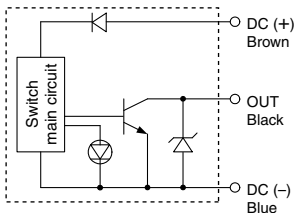

D-M9P(V)

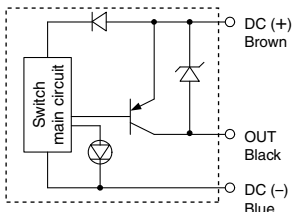

D-M9B(V)

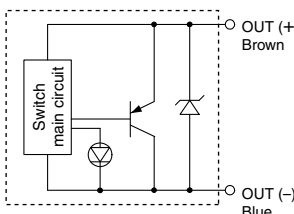

Auto Switch Specifications

PLC: Programmable Logic Controller

D-M9□(V) (With indicator light)						
Auto switch model	D-M9N	D-M9NV	D-M9P	D-M9PV	D-M9B	D-M9BV
Electrical entry direction	In-line	Perpendicular	In-line	Perpendicular	In-line	Perpendicular
Wiring type	3-wire			2-wire		
Output type	NPN		PNP		—	
Applicable load	IC circuit, Relay, PLC				24 VDC relay, PLC	
Power supply voltage	5, 12, 24 VDC (4.5 to 28 V)				—	
Current consumption	10 mA or less				—	
Load voltage	28 VDC or less		—		24 VDC (10 to 28 VDC)	
Load current	40 mA or less				2.5 to 40 mA	
Internal voltage drop	0.8 V or less at 10 mA (2 V or less at 40 mA)				4 V or less	
Leakage current	100 μA or less at 24 VDC				0.8 mA or less	
Indicator light	Red LED illuminates when turned ON.					
Standards	CE marking					

- Lead wires — Oilproof heavy-duty vinyl cable: $\phi 2.7 \times 3.2$ ellipse

D-M9B(V) 0.15 mm² x 2 cores

D-M9N(V), D-M9P(V) 0.15 mm² x 3 cores

Note 1) Refer to page 58 for solid state switch common specifications.

Note 2) Refer to page 58 for lead wire lengths.

Weight

Unit: g

Auto switch model	D-M9N(V)	D-M9P(V)	D-M9B(V)
Lead wire length (m)	0.5	8	7
	1	14	13
	3	41	38
	5	68	63

Dimensions

Unit: mm

D-M9□

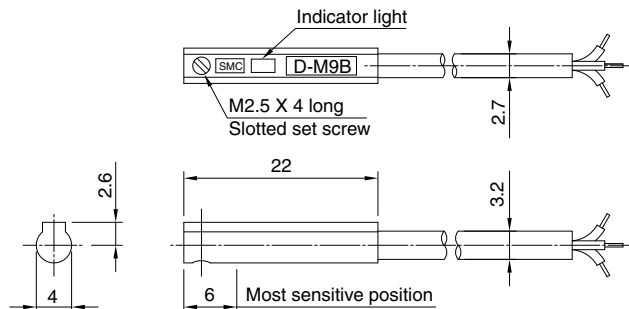

D-M9□V

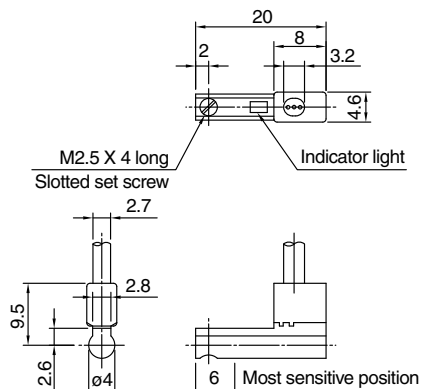

Solid State Switch: Band Mounting Style D-H7C



Connector

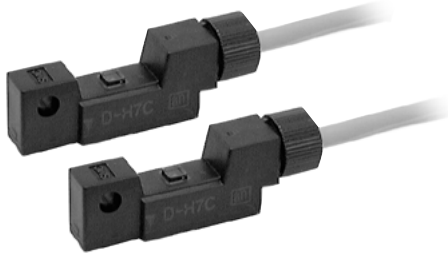

⚠ Caution

Operating Precautions

1. Confirm that the connector is appropriately tightened. If tightened insufficiently, the waterproof performance will deteriorate.
2. For how to handle a connector, refer to Best Pneumatics catalog.

Auto Switch Internal Circuit

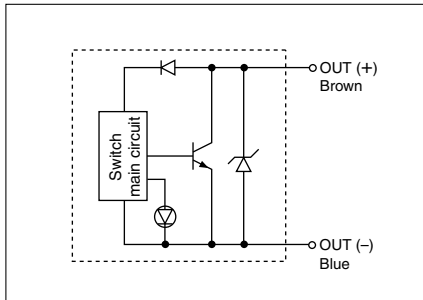

Auto Switch Specifications

PLC: Programmable Logic Controller

D-H7C (With indicator light)	
Auto switch part no.	D-H7C
Wiring type	2-wire
Output type	—
Applicable load	24 VDC Relay, PLC
Power supply voltage	—
Current consumption	—
Load voltage	24 VDC (10 to 28 VDC)
Load current	5 to 40 mA
Internal voltage drop	4 V or less
Leakage current	0.8 mA or less at 24 VDC
Indicator light	Red LED illuminates when ON.
Standard	Conforming to CE

- Lead wires — Oilproof heavy-duty vinyl cable: $\phi 3.4$, 0.2 mm² x 2 cores (Brown, Blue), 0.5 m
- Note 1) Refer to page 58 for solid state switch common specifications.
Note 2) Refer to page 58 for lead wire lengths and lead wire with connector.

Weight

Unit: g

Auto switch part no.	D-H7C	
Lead wire length (m)	0.5	15
	3	54
	5	85

Dimensions

Unit: mm

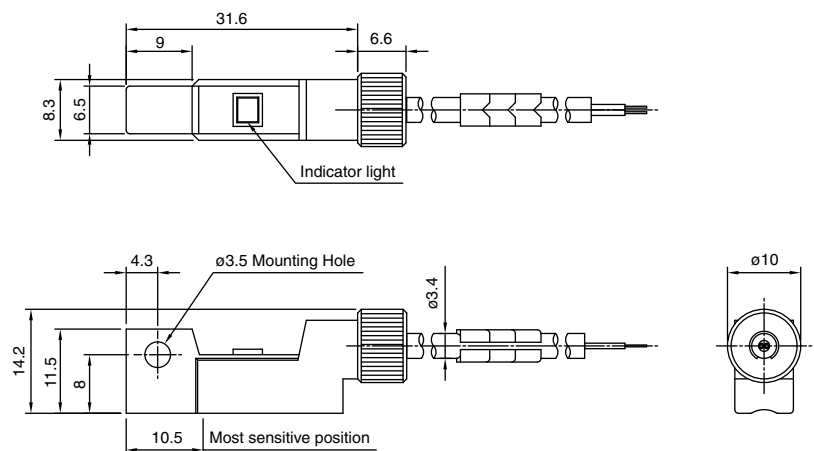

2-Color Indication Solid State Switch: Direct Mounting Style

D-M9NW(V)/D-M9PW(V)/D-M9BW(V)

Grommet

- 2-wire load current is reduced (2.5 to 40 mA).
- RoHS compliant
- Flexibility is 1.5 times greater than the conventional model (SMC comparison).
- Using flexible cable as standard spec.
- The optimum operating position can be determined by the color of the light. (Red → Green ← Red)



Auto Switch Specifications

PLC: Programmable Logic Controller

D-M9□W/D-M9□WV (With indicator light)						
Auto switch part no.	D-M9NW	D-M9NWV	D-M9PW	D-M9PWV	D-M9BW	D-M9BWV
Electrical entry direction	In-line	Perpendicular	In-line	Perpendicular	In-line	Perpendicular
Wiring type	3-wire				2-wire	
Output type	NPN		PNP		—	
Applicable load	IC circuit, Relay, PLC				24 VDC relay, PLC	
Power supply voltage	5, 12, 24 VDC (4.5 to 28 V)				—	
Current consumption	10 mA or less				—	
Load voltage	28 VDC or less		—		24 VDC (10 to 28 VDC)	
Load current	40 mA or less				2.5 to 40 mA	
Internal voltage drop	0.8 V or less at 10 mA (2 V or less at 40 mA)				4 V or less	
Leakage current	100 μA or less at 24 VDC				0.8 mA or less	
Indicator light	Operating position Red LED illuminates. Optimum operating position Green LED illuminates.					
Standard	Conforming to CE					

- Lead wires — Oilproof flexible heavy-duty vinyl cable: $\phi 2.7 \times 3.2$ ellipse
 D-M9BW(V) 0.15 mm² x 2 cores
 D-M9NW(V), D-M9PW(V) 0.15 mm² x 3 cores

Note 1) Refer to page 58 for solid state switch common specifications.

Note 2) Refer to page 58 for lead wire lengths.

Auto Switch Internal Circuit

D-M9NW(V)

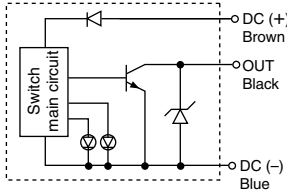

D-M9PW(V)

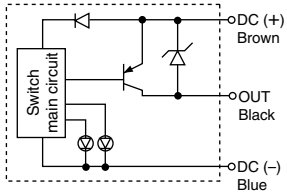

D-M9BW(V)

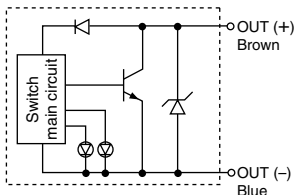

Indicator light / Display method

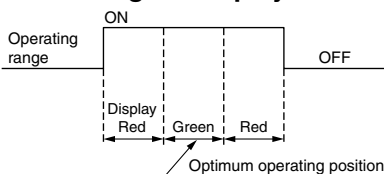

Weight

Unit: g

Auto switch part no.	D-M9NW(V)	D-M9PW(V)	D-M9BW(V)	
Lead wire length (m)	0.5	8	8	7
	1	14	14	13
	3	41	41	38
	5	68	68	63

Dimensions

Unit: mm

D-M9□W

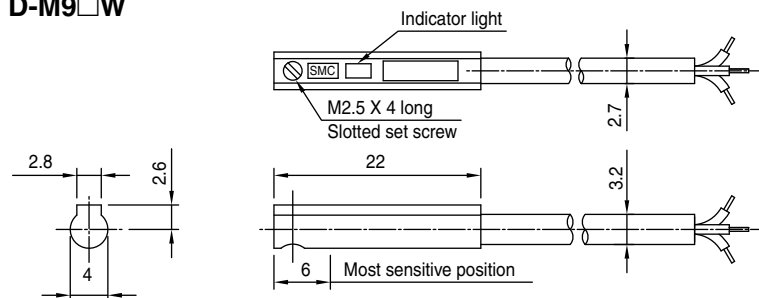

D-M9□WV

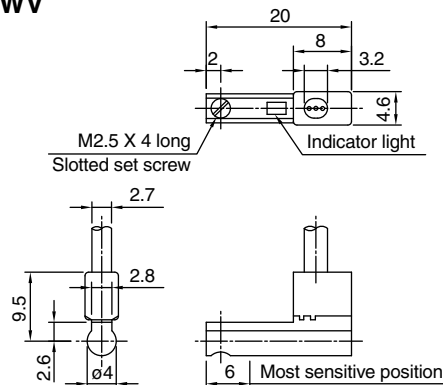

Water Resistant 2-Color Indication Solid State Switch: Band Mounting Style D-H7BAL



Grommet

Water (coolant) resistant type

- The optimum operating position can be determined by the color of the light. (Red → Green ← Red)



Caution

Operating Precautions

Consult SMC if using coolant liquid other than water based solution.

Auto Switch Specifications

PLC: Programmable Logic Controller

D-H7BAL (With indicator light)	
Auto switch part no.	D-H7BAL
Wiring type	2-wire
Output type	—
Applicable load	24 VDC Relay, PLC
Power supply voltage	—
Current consumption	—
Load voltage	24 VDC (10 to 28 VDC)
Load current	5 to 40 mA
Internal voltage drop	4 V or less
Leakage current	0.8 mA or less at 24 VDC
Indicator light	Operating position Red LED illuminates. Optimum operating position Green LED illuminates.
Standard	Conforming to CE

- Lead wires — Oilproof heavy-duty vinyl cable: $\phi 3$, $\phi 4$, $0.2 \text{ mm}^2 \times 2$ cores (Brown, Blue), 3 m (Standard)

Note 1) Refer to page 58 for solid state switch common specifications.

Note 2) Refer to page 58 for lead wire lengths.

Weight

Unit: g

Auto switch part no.	D-H7BA	
Lead wire length (m)	0.5	—
	3	50
	5	81

Auto Switch Internal Circuit

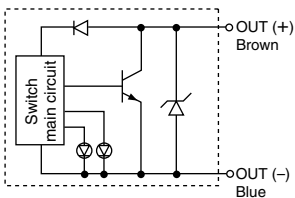

Indicator light / Display method

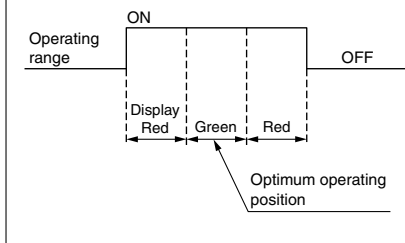

Dimensions

Unit: mm

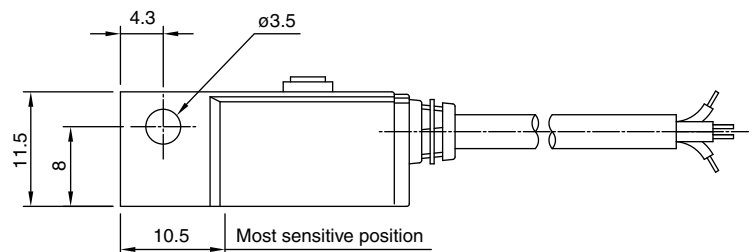
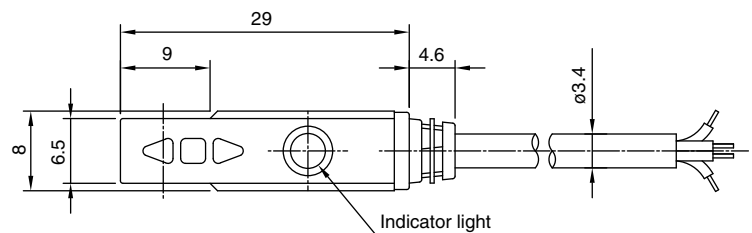

2-Color Indication with Diagnostic Output Solid State Switch: Band Mounting Style D-H7NF



Grommet

Since the output signal can be detected in an unsteady detecting area, the difference of detecting position can be confirmed by the side of PLC (Programmable Logic Controller).

- The optimum operating position can be determined by the color of the light.
(Red → Green ← Red)



Auto Switch Internal Circuit

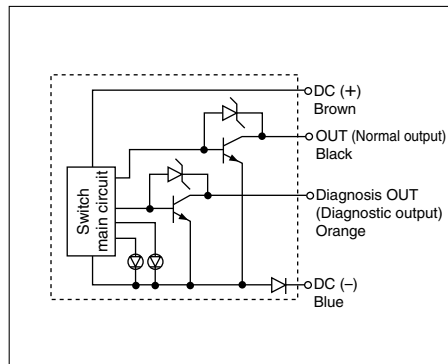

Auto Switch Specifications

PLC: Programmable Logic Controller

D-H7NF (With indicator light)	
Auto switch part no.	D-H7NF
Wiring type	4-wire
Output type	NPN
Diagnostic output type	Normal operation
Applicable load	IC circuit, Relay, PLC
Power supply voltage	5, 12, 24 VDC (4.5 to 28 VDC)
Current consumption	10 mA or less
Load voltage	28 VDC or less
Load current	50 mA or less at the total amount of normal output and diagnostic output
Internal voltage drop	1.5 V or less (0.8 V or less at 5 mA)
Leakage current	100 μ A or less at 24 VDC
Indicator light	Operating position Red LED illuminates. Optimum operating position Green LED illuminates.
Standard	Conforming to CE

- Lead wires — Oilproof heavy-duty vinyl cable: ϕ 3.4, 0.2 mm² x 4 cores (Brown, Black, Orange, Blue), 0.5 m
- Note 1) Refer to page 58 for solid state switch common specifications.
- Note 2) Refer to page 58 for lead wire lengths.

Weight

Unit: g

Auto switch part no.		D-H7NF
Lead wire length (m)	0.5	13
	3	56
	5	90

Diagnostic Output Operation

The diagnostic signal is output within unsteady detecting area (where indicator light is Red), and the diagnostic output becomes OFF when the detecting position remains within the optimum operating position (where indicator is Green). When the detecting position is not adjusted, the diagnostic output becomes ON.

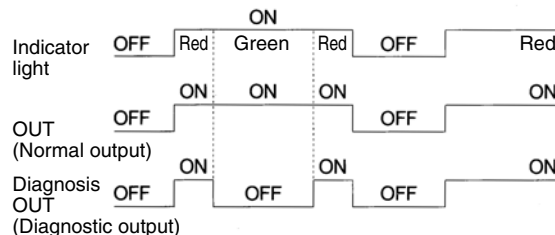

Dimensions

Unit: mm

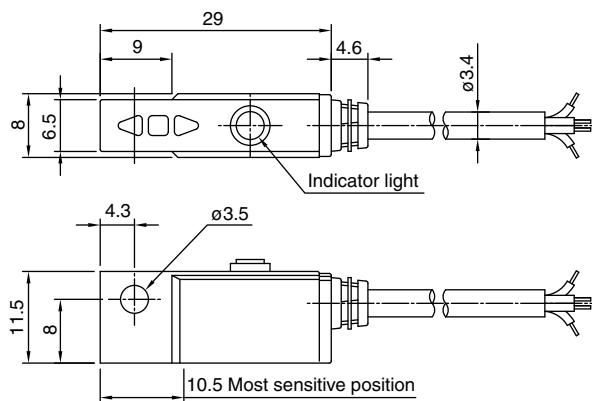

Reed Switch: Direct Mounting Style

D-A90(V)/D-A93(V)/D-A96(V)

Grommet



⚠ Caution

Precautions

Fix the auto switch with the existing screw installed on the switch body. The auto switch may be damaged if a screw other than the one supplied is used.

Auto Switch Internal Circuit

D-A90(V)

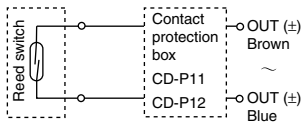

D-A93(V)

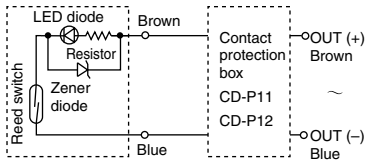

D-A96(V)

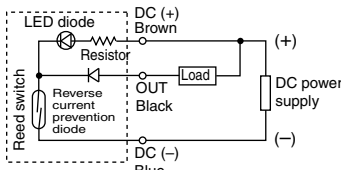

- Note) ① In a case where the operation load is an inductive load.
 ② In a case where the wiring load is greater than 5 m.
 ③ In a case where the load voltage is 100 VAC.

Use the auto switch with a contact protection box in any of the above mentioned cases. (For details about the contact protection box, refer to page 58.)

Auto Switch Specifications

PLC: Programmable Logic Controller

D-A90(V) (Without indicator light)			
Auto switch model	D-A90/D-A90V		
Applicable load	IC circuit, Relay, PLC		
Load voltage	24 VAC/DC or less	48 VAC/DC or less	100 VAC/DC or less
Maximum load current	50 mA	40 mA	20 mA
Contact protection circuit	None		
Internal resistance	1 Ω or less (including lead wire length of 3 m)		
Standards	CE marking		
D-A93(V)/D-A96(V) (With indicator light)			
Auto switch model	D-A93/D-A93V	D-A96/D-A96V	
Applicable load	Relay, PLC		IC circuit
Load voltage	24 VDC	100 VAC	4 to 8 VDC
Load current range and max. load current ^{Note 3)}	5 to 40 mA	5 to 20 mA	20 mA
Contact protection circuit	None		
Internal resistance	D-A93 — 2.4 V or less (to 20 mA)/3 V or less (to 40 mA) D-A93V — 2.7 V or less		0.8 V or less
Indicator light	Red LED illuminates when turned ON.		
Standards	CE marking		

- Lead wires
 D-A90(V)/D-A93(V) — Oilproof heavy-duty vinyl cable: $\phi 2.7$, 0.18 mm² x 2 cores (Brown, Blue), 0.5 m
 D-A96(V) — Oilproof heavy-duty vinyl cable: $\phi 2.7$, 0.15 mm² x 3 cores (Brown, Black, Blue), 0.5 m
 Note 1) Refer to page 58 for reed switch common specifications.
 Note 2) Refer to page 58 for lead wire lengths.
 Note 3) Under 5 mA, the visibility of an indicator light is worsen. Furthermore, although it could be impossible to recognize it under 2.5 mA, but there would be no problem only with 1 mA or more in terms of the contact output.

Weight

Model	D-A90	D-A90V	D-A93	D-A93V	D-A96	D-A96V
Lead wire length (m)	0.5	6	6	6	8	8
	3	30	30	30	41	41

Dimensions

Unit: mm

D-A90/D-A93/D-A96

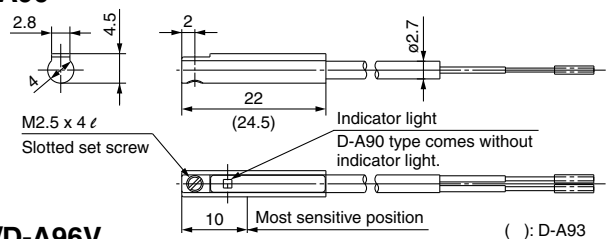

D-A90V/D-A93V/D-A96V

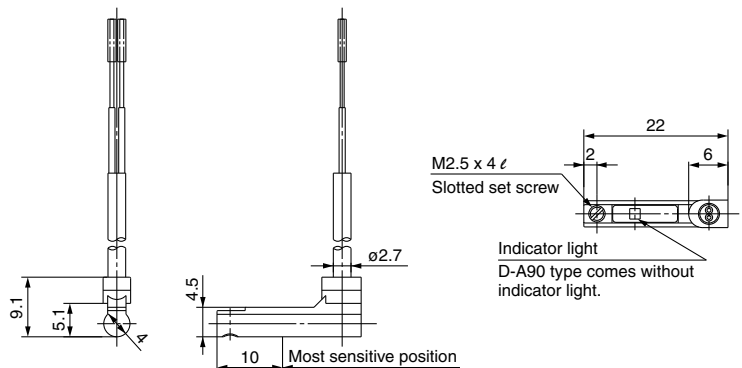

Reed Switch: Band Mounting Style D-B54/D-B64



Grommet



Auto Switch Specifications

PLC: Programmable Logic Controller

D-B5 (With indicator light)			
Auto switch part no.	D-B54		
Applicable load	Relay, PLC		
Load voltage	24 VDC	100 VAC	200 VAC
Load current range ^{Note 3)}	5 to 50 mA	5 to 25 mA	5 to 12.5 mA
Contact protection circuit	Built-in		
Internal voltage drop	2.4 V or less (to 20 mA)/3.5 V or less (to 50 mA)		
Indicator light	Red LED illuminates when turned ON.		
Standard	Conforming to CE		
D-B6 (Without indicator light)			
Auto switch part no.	D-B64		
Applicable load	Relay, PLC		
Load voltage	24 VAC/DC or less	100 VAC	200 VAC
Maximum load current	Max. 50 mA	Max. 25 mA	Max. 12.5 mA
Contact protection circuit	Built-in		
Internal resistance	25 Ω or less		
Standard	Conforming to CE		

● Lead wires — Oilproof heavy-duty vinyl cable: $\phi 4$, 0.3 mm² x 2 cores (Brown, Blue), 0.5 m

Note 1) Refer to page 58 for reed switch common specifications.

Note 2) Refer to page 58 for lead wire lengths.

Note 3) Under 5 mA, the strength of the indicator light is poor. In some cases, visibility of the indicator light will not be possible where the output signal is less than 2.5 mA. However, there is no problem in terms of contact output, when an output signal exceeds 1 mA or more.

Auto Switch Internal Circuit

D-B54

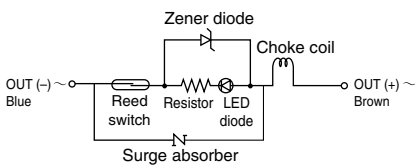

D-B64

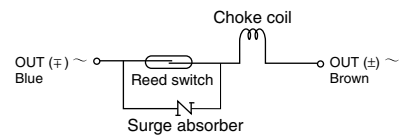

Weight

Unit: g

Auto switch part no.	D-B54	D-B64
Lead wire length (m)	0.5	22
	3	78
	5	126

Dimensions

Unit: mm

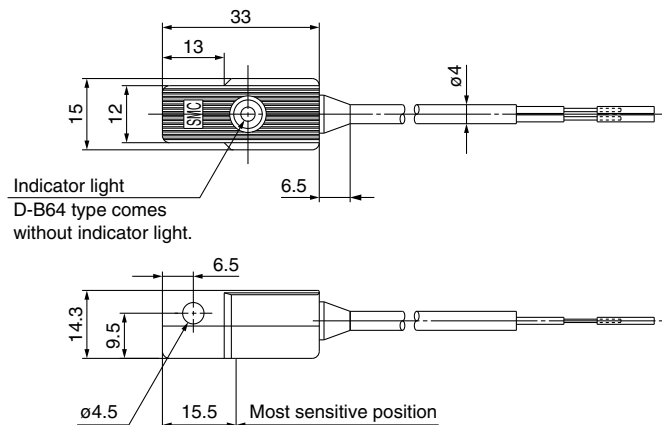

Reed Switch: Band Mounting Style D-C73C/D-C80C



Connector



⚠ Caution

Operating Precautions

1. Confirm that the connector is appropriately tightened. If tightened insufficiently, the waterproof performance will deteriorate.
2. For how to handle a connector, refer to "Best Pneumatics 2004" Vol. 6 catalog.

Auto Switch Internal Circuit

D-C73C

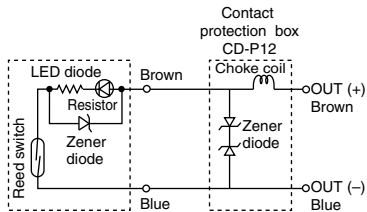

D-C80C

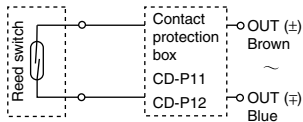

- Note) ① In a case where the operation load is an inductive load.
② In a case where the wiring load is greater than 5 m.

Use the contact protection box in any of the above listed situations. The contact point life may decrease. (Refer to page 58 for contact protection box.)

Auto Switch Specifications

PLC: Programmable Logic Controller

D-C73C (With indicator light)	
Auto switch part no.	D-C73C
Applicable load	Relay, PLC
Load voltage	24 VDC
Load current range ^{Note 4)}	5 to 40 mA
Contact protection circuit	None
Internal voltage drop	2.4 V or less
Indicator light	Red LED illuminates when turned ON.
Standard	Conforming to CE

D-C80C (Without indicator light)	
Auto switch part no.	D-C80C
Applicable load	Relay, PLC
Load voltage	24 VAC/DC or less
Maximum load current	50 mA
Contact protection circuit	None
Internal resistance	1 Ω or less (including lead wire length of 3 m)
Standard	Conforming to CE

● Lead wires — Oilproof heavy-duty vinyl cable: $\phi 3.4$, 0.2 mm² x 2 cores (Brown, Blue), 0.5 m

Note 1) Refer to page 58 for reed switch common specifications.

Note 2) Refer to page 58 for lead wire lengths.

Note 3) Lead wire with connector may be shipped with switch.

Note 4) Under 5 mA, the strength of the indicator light is poor. In some cases, visibility of the indicator light will not be possible where the output signal is less than 2.5 mA. However, there is no problem in terms of contact output, when an output signal exceeds 1 mA or more.

Weight

Unit: g

Auto switch part no.	D-C73C	D-C80C
Lead wire length (m)	0.5	14
	3	53
	5	83

Dimensions

Unit: mm

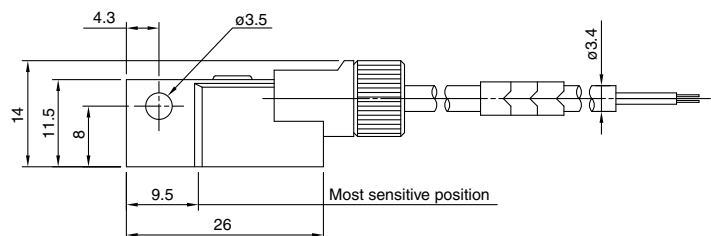
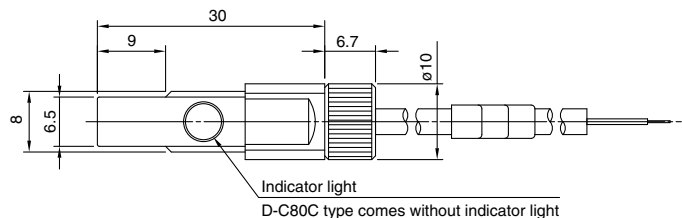

2-Color Indication Reed Switch: Band Mounting Style D-B59W



Grommet

- The optimum operating position can be determined by the color of the light. (Red → Green ← Red)

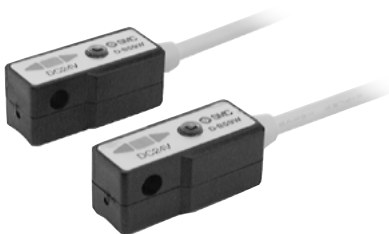

Auto Switch Specifications

PLC: Programmable Logic Controller

D-B59W (With indicator light)	
Auto switch part no.	D-B59W
Applicable load	Relay, PLC
Load voltage	24 VDC
Load current range ^{Note 3)}	5 to 40 mA
Contact protection circuit	Built-in
Internal voltage drop	4 V or less
Indicator light	Operating position Red LED illuminates. Optimum operating position Green LED illuminates.
Standard	Conforming to CE

- Lead wires — Oilproof heavy-duty vinyl cable: $\phi 4$, $0.3 \text{ mm}^2 \times 2$ cores (Brown, Blue), 0.5 m

Note 1) Refer to page 58 for reed switch common specifications.

Note 2) Refer to page 58 for lead wire lengths.

Note 3) Under 5 mA, the strength of the indicator light is poor. In some cases, visibility of the indicator light will not be possible where the output signal is less than 2.5 mA. However, there is no problem in terms of contact output, when an output signal exceeds 1 mA or more.

Auto Switch Internal Circuit

D-B59W

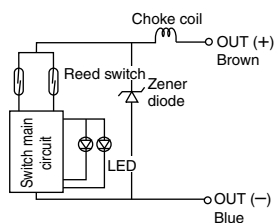

Indicator light / Display method

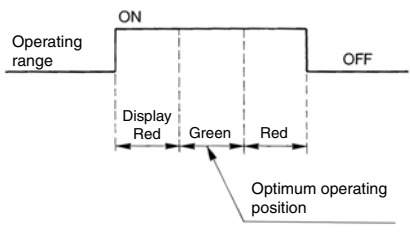

Weight

Unit: g

Auto switch part no.		D-B59W
Lead wire length (m)	0.5	20
	3	76
	5	—

Dimensions

Unit: mm

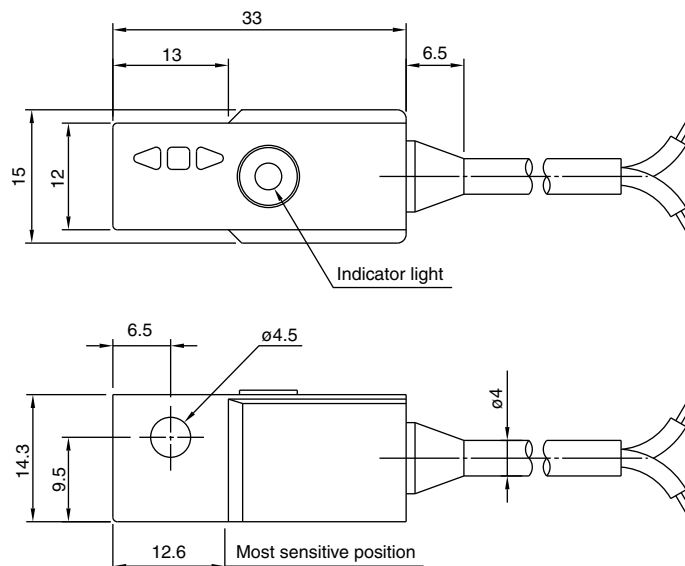





Safety Instructions

These safety instructions are intended to prevent hazardous situations and/or equipment damage. These instructions indicate the level of potential hazard with the labels of “**Caution,**” “**Warning**” or “**Danger.**” They are all important notes for safety and must be followed in addition to International Standards (ISO/IEC), Japan Industrial Standards (JIS)*¹⁾ and other safety regulations*²⁾.

- * 1) ISO 4414: Pneumatic fluid power – General rules relating to systems.
ISO 4413: Hydraulic fluid power – General rules relating to systems.
IEC 60204-1: Safety of machinery – Electrical equipment of machines. (Part 1: General requirements)
ISO 10218-1992: Manipulating industrial robots -Safety.
JIS B 8370: General rules for pneumatic equipment.
JIS B 8361: General rules for hydraulic equipment.
JIS B 9960-1: Safety of machinery – Electrical equipment of machines. (Part 1: General requirements)
JIS B 8433-1993: Manipulating industrial robots - Safety.
etc.
- * 2) Labor Safety and Sanitation Laws, etc.

 **Caution:** Operator error could result in injury or equipment damage.

 **Warning:** Operator error could result in serious injury or loss of life.

 **Danger :** In extreme conditions, there is a possibility of serious injury or loss of life.

Warning

1. The compatibility of the product is the responsibility of the person who designs the equipment or decides its specifications.

Since the product specified here is used under various operating conditions, its compatibility with specific equipment must be decided by the person who designs the equipment or decides its specifications based on necessary analysis and test results. The expected performance and safety assurance of the equipment will be the responsibility of the person who has determined its compatibility with the product. This person should also continuously review all specifications of the product referring to its latest catalog information, with a view to giving due consideration to any possibility of equipment failure when configuring the equipment.

2. Only personnel with appropriate training should operate machinery and equipment.

The product specified here may become unsafe if handled incorrectly. The assembly, operation and maintenance of machines or equipment including our products must be performed by an operator who is appropriately trained and experienced.

3. Do not service or attempt to remove product and machinery/equipment until safety is confirmed.

1. The inspection and maintenance of machinery/equipment should only be performed after measures to prevent falling or runaway of the driven objects have been confirmed.
2. When the product is to be removed, confirm that the safety measures as mentioned above are implemented and the power from any appropriate source is cut, and read and understand the specific product precautions of all relevant products carefully.
3. Before machinery/equipment is restarted, take measures to prevent unexpected operation and malfunction.

4. Contact SMC beforehand and take special consideration of safety measures if the product is to be used in any of the following conditions.

1. Conditions and environments outside of the given specifications, or use outdoors or in a place exposed to direct sunlight.
2. Installation on equipment in conjunction with atomic energy, railways, air navigation, space, shipping, vehicles, military, medical treatment, combustion and recreation, or equipment in contact with food and beverages, emergency stop circuits, clutch and brake circuits in press applications, safety equipment or other applications unsuitable for the standard specifications described in the product catalog.
3. An application which could have negative effects on people, property, or animals requiring special safety analysis.
4. Use in an interlock circuit, which requires the provision of double interlock for possible failure by using a mechanical protective function, and periodical checks to confirm proper operation.



Safety Instructions

Caution

The product is provided for use in manufacturing industries.

The product herein described is basically provided for peaceful use in manufacturing industries.

If considering using the product in other industries, consult SMC beforehand and exchange specifications or a contract if necessary. If anything is unclear, contact your nearest sales branch. (1-800-SMC-SMC1)

Limited Warranty and Disclaimer/Compliance Requirements

The product used is subject to the following “Limited Warranty and Disclaimer” and “Compliance Requirements”. Read and accept them before using the product.

Limited Warranty and Disclaimer

1. The warranty period of the product is 1 year in service or 1.5 years after the product is delivered.*3)

Also, the product may have specified durability, running distance or replacement parts. Please consult your nearest sales branch.

2. For any failure or damage reported within the warranty period which is clearly our responsibility, a replacement product or necessary parts will be provided.

This limited warranty applies only to our product independently, and not to any other damage incurred due to the failure of the product.

3. Prior to using SMC products, please read and understand the warranty terms and disclaimers noted in the specified catalog for the particular products.

* 3) Vacuum pads are excluded from this 1 year warranty.

A vacuum pad is a consumable part, so it is warranted for a year after it is delivered.

Also, even within the warranty period, the wear of a product due to the use of the vacuum pad or failure due to the deterioration of rubber material are not covered by the limited warranty.

Compliance Requirements

When the product is exported, strictly follow the laws required by the Department of Commerce, International Trade Administration (Foreign Exchange and Foreign Trade Control Law).



Series NCM Actuators Precautions 1

Be sure to read this before handling.

Design and Selection

Warning

1. **There is a danger of sudden action by air cylinders if sliding parts of machinery are twisted, etc., and changes in forces occur.**

In such cases, human injury may occur; e.g., by catching hands or feet in the machinery, or damage to the machinery itself may occur. Therefore, the machine should be designed to avoid such dangers.

2. **Install a protective cover when there is a risk of human injury**

If a driven object and moving parts of a cylinder pose a danger of human injury, design the structure to avoid contact with the human body.

3. **Securely tighten all stationary parts and connected parts so that they will not become loose.**

Especially when a cylinder operates with high frequency or is installed where there is a lot of vibration, ensure that all parts remain secure.

4. **A deceleration circuit may be required.**

When a driven object is operated at high speed or the load is heavy, a cylinder's cushion will not be sufficient to absorb the impact. Install a deceleration circuit to reduce the speed before cushioning to relieve the impact. In this case, the rigidity of the machinery should also be examined.

5. **Consider a possible drop in operating pressure due to a power outage, etc.**

When a cylinder is used in a clamping mechanism, there is a danger of work pieces dropping if there is a decrease in clamping force due to a drop in circuit pressure caused by a power outage, etc. Therefore, safety equipment should be installed to prevent damage to machinery and/or human injury. Suspension mechanisms and lifting devices also require consideration for drop prevention.

6. **Consider a possible loss of power source.**

Measures should be taken to protect against human injury and equipment damage in the event that there is a loss of power to equipment controlled by air pressure, electricity or hydraulics, etc.

7. **Design circuitry to prevent sudden lurching of driven objects.**

When a cylinder is driven by an exhaust center type directional control valve or when starting up after residual pressure is exhausted from the circuit, etc., the piston and its driven object will lurch at high speed if pressure is applied to one side of the cylinder because of the absence of air pressure inside the cylinder. Therefore, select equipment and design circuits to prevent sudden lurching, because there is a danger of human injury and/or damage to equipment when this occurs.

8. **Consider emergency stops.**

Design so that human injury and/or damage to machinery and equipment will not be caused when machinery is stopped by a safety device under abnormal conditions, such as a power outage or a manual emergency stop.

9. **Consider the action when operation is restarted after an emergency stop or abnormal stop.**

Design the machinery so that human injury or equipment damage will not occur upon restart of operation. When the cylinder has to be reset at the starting position, install safe manual control equipment.

Warning

1. **Confirm the specifications.**

The products advertised in this catalog are designed according to use in industrial compressed air systems. If the products are used in conditions where pressure, temperature, etc., are out of specification, damage and/or malfunction may be caused. Do not use in these conditions. (Refer to the specifications.) Consult SMC if you use a fluid other than compressed air.

2. **Intermediate stops**

When intermediate stopping of a cylinder piston is performed with a 3 position closed center type directional control valve, it is difficult to achieve stopping positions as accurate and precise as with hydraulic pressure due to the compressibility of air.

Furthermore, since valves and cylinders, etc., are not guaranteed for zero air leakage, it may not be possible to hold a stopped position for an extended period of time. Contact SMC in case it is necessary to hold a stopped position for an extended period.

Caution

1. **Operate within the limits of the maximum usable stroke.**

The piston rod will be damaged if operated beyond the maximum stroke. Refer to the air cylinder model selection procedure for the maximum useable stroke.

2. **Operate the piston within a range such that collision damage will not occur at the stroke end.**

Operate within a range such that damage will not occur when the piston having inertial force stops by striking the cover at the stroke end. Refer to the cylinder model selection procedure for the range within which damage will not occur.

3. **Use a speed controller to adjust the cylinder drive speed, gradually increasing from a low speed to the desired speed setting.**

4. **Provide intermediate supports for long stroke cylinders.**

Provide intermediate supports for cylinders with long strokes to prevent rod damage due to sagging of the rod, deflection of the tube, vibration and external loads, etc.

It is assumed the persons determining the stroke requirements have technical training and expertise in the design limitations of pneumatic equipment and are aware that death, personal injury, and property damage may result from the improper use of these products. Proper use is the users responsibility.



Series NCM Actuators Precautions 2

Be sure to read this before handling.

Mounting

⚠ Caution

1. Be certain to align the rod axis with the load and direction of movement when connecting.

When not properly aligned, the rod and tube may be twisted, and damage may be caused due to wear on areas such as the inner tube surface, bushings, rod surface and seals.

2. When an external guide is used, connect the rod end and the load in such a way that there is no interference at any point within the stroke.

3. Do not scratch or gouge the sliding parts of the cylinder tube or piston rod, etc., by striking or grasping them with other objects.

Cylinder bores are manufactured to precise tolerances, so that even a slight deformation may cause malfunction. Also, scratches or gouges, etc., in the piston rod may lead to damaged seals and cause air leakage.

4. Prevent the seizure of rotating parts.

Prevent the seizure of rotating parts (pins, etc.) by applying grease.

5. Do not use until you can verify that equipment can operate properly.

Verify correct mounting by appropriate function and leakage inspections after compressed air and power are connected following mounting, maintenance or conversions.

6. Instruction manual

The product should be mounted and operated after thoroughly reading the manual and understanding its contents.

Keep the instruction manual where it can be referred to as needed.

7. Preparation before piping

Before piping is connected, it should be thoroughly blown out with air (flushing) or washed to remove chips, cutting oil and other debris from inside the pipe.

8. Wrapping of pipe tape

When screwing together pipes and fittings, etc., be certain that chips from the pipe threads and sealing material do not get inside the piping.

Also, when pipe tape is used, leave 1.5 to 2 thread ridges exposed at the end of the threads.

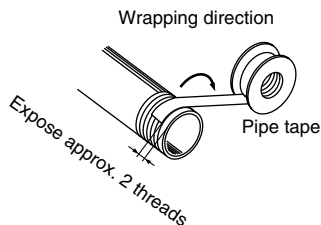

9. Mount an auto switch at the center of the operating range.

Adjust the mounting position of an auto switch so that the piston stops at the center of the operating range (the range in which a switch is ON). (The mounting position shown in the catalog indicates the optimum position at stroke end.) If mounted at the end of the operating range (around the borderline of ON and OFF), operation will be unstable.

Cushion

⚠ Caution

1. Readjust using the cushion needle.

Cushion is adjusted at the factory, however, the cushion needle on the cover should be readjusted when the product is put into service, based upon factors such as the size of the load and the operating speed. When the cushion needle is turned clockwise, the restriction becomes smaller and the cushion's effectiveness is increased. Tighten the lock nut securely after adjustment is performed.

2. Do not operate with the cushion needle in a fully closed condition.

This will cause damage to the seals.

⚠ Warning

1. Use clean air.

Do not use compressed air which includes chemicals, synthetic oils containing organic solvents, salt or corrosive gases, etc., as it can cause damage or malfunction.

⚠ Caution

1. Install air filters.

Install air filters at the upstream side of valves. The filtration degree should be 5 μ m or finer.

2. Install an after-cooler, air dryer or water separator, etc.

Air that includes excessive drainage may cause malfunction of valves and other pneumatic equipment. To prevent this, install an after-cooler, air dryer or water separator, etc.

3. Use the product within the specified range of fluid and ambient temperature.

Take measures to prevent freezing, since moisture in circuits can be frozen below 5°C, and this may cause damage to seals and lead to malfunction.

Refer to "Best Pneumatics 2004" Vol.14 catalog for further details on compressed air quality.

Maintenance

⚠ Warning

1. Removal of equipment, and supply/exhaust of compressed air.

When equipment is removed, first check measures to prevent dropping of driven objects and run-away of equipment, etc. Then cut off the supply pressure and electric power, and exhaust all compressed air from the system.

When machinery is restarted, proceed with caution after confirming measures to prevent cylinder from lurching.

⚠ Caution

1. Drain flushing

Remove drainage from air filters regularly. (Refer to the specifications.)



Series NCM Auto Switches Precautions 1

Be sure to read this before handling.

Design and Selection

Warning

1. Confirm the specifications.

Read the specifications carefully and use this product appropriately. The product may be damaged or malfunction if it is used outside the range of specifications for current load, voltage, temperature or impact.

2. Cautions for use in an interlock circuit

When an auto switch is used for an interlock signal requiring high reliability, devise a double interlock system to avoid trouble by providing a mechanical protection function, or by also using another switch (sensor) together with the auto switch.

Also, perform periodic maintenance and confirm proper operation.

3. Do not make any modifications (including exchanging the printed circuit boards) to the product.

It may cause human injuries and accidents.

Caution

1. Pay attention to the length of time that a switch is ON at an intermediate stroke position.

When an auto switch is placed at an intermediate position of the stroke and a load is driven at the time the piston passes, the auto switch will operate, but if the speed is too great the operating time will be shortened and the load may not operate properly. The maximum detectable piston speed is:

$$V \text{ (mm/s)} = \frac{\text{Auto switch operating range (mm)}}{\text{Time load applied (ms)}} \times 1000$$

In cases of high piston speed, the use of an auto switch (G5NTL) with a built-in OFF delay timer (≈ 200 ms) makes it possible to extend the load operating time.

2. Keep wiring as short as possible.

<Reed switches>

As the length of the wiring to a load gets longer, the rush current at switching ON becomes greater, and this may shorten the product's life. (The switch will stay ON all the time.)

- 1) Use a contact protection box when the wire length is 5 m or longer.
- 2) Even if an auto switch has a built-in contact protection circuit, when the wiring is more than 30 m long, it is not able to adequately absorb the rush current and its life may be reduced. It is again necessary to connect a contact protection box in order to extend its life. Please contact SMC in this case.

<Solid state switches>

- 3) Although wire length should not affect switch function, use a wire 100 m or shorter.

If the wiring is longer it will likely increase noise although the length is less than 100 m.

When the wire length is long, we recommend attaching the ferrite core to the both ends of the cable to prevent excess noise.

A contact protection box is not required for solid state switches due to their construction.

3. Do not use a load that generates surge voltage. If a surge voltage is generated, the discharge occurs at the contact, possibly resulting in the shortening of product life.

<Reed switches>

If driving a load such as a relay that generates a surge voltage, use an auto switch with built-in contact protection circuit or use a contact protection box.

<Solid state switches>

Although a zener diode for surge protection is connected at the output side of a solid state auto switch, damage may still occur if the surge is applied repeatedly. When a load, such as a relay or solenoid which generates surge is directly driven, use a type of switch with a built-in surge absorbing element.

4. Take precautions when multiple cylinders (actuators) are used close together.

When multiple auto switch cylinders (actuators) are used in close proximity, magnetic field interference may cause the auto switches to malfunction. Maintain a minimum cylinder separation of 40 mm.

(When the allowable interval is specified for each cylinder series, use the indicated value.) The auto switches may malfunction due to the interference from the magnetic fields.



Series NCM Auto Switches Precautions 2

Be sure to read this before handling.

Design and Selection

⚠ Caution

5. Pay attention to the internal voltage drop of the auto switch.

<Reed switches>

- 1) Auto switches with an indicator light (Except D-A96, C76)
- If auto switches are connected in series as shown below, take note that there will be a large voltage drop because of internal resistance in the light emitting diodes. (Refer to the internal voltage drop in the auto switch specifications.) [The voltage drop will be “n” times larger when “n” auto switches are connected.] Even though an auto switch operates normally, the load may not operate.

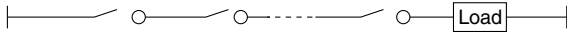

- In the same way, when operating under a specified voltage, although an auto switch may operate normally, the load may not operate. Therefore, the formula below should be satisfied after confirming the minimum operating voltage of the load.

$$\text{Supply voltage} - \text{Internal voltage drop of auto switch} > \text{Minimum operating voltage of load}$$

- 2) If the internal resistance of a light emitting diode causes a problem, select an auto switch without an indicator light (Model D-A90, C80).

<Solid state switches>

- 3) Generally, the internal voltage drop will be greater with a 2-wire solid state auto switch than with a reed switch. Take the same precautions as in 1). Also, note that a 12 VDC relay is not applicable.

6. Pay attention to leakage current.

<Solid state switches>

With a 2-wire solid state auto switch, current (leakage current) flows to the load to operate the internal circuit even when in the OFF state.

Operating current of load (OFF condition) > Leakage current
If the criteria given in the above formula are not met, it will not reset correctly (stays ON). Use a 3-wire switch if this specification will not be satisfied.

Moreover, leakage current flow to the load will be “n” times larger when “n” auto switches are connected in parallel.

7. Ensure sufficient clearance for maintenance activities.

When designing an application, be sure to allow sufficient clearance for maintenance and inspections.

⚠ Warning

8. When multiple auto switches are required

“n” indicates the number of auto switch which can be physically mounted. Detection intervals depends on the auto switch mounting structure and set position therefore some required interval and set positions may not be available.

9. Limitations of detectable positioning

When using certain mounting brackets, the surface and position where an auto switch can be mounted maybe restricted due to physical interference. For example, when using some bracket types the auto switch cannot be surface mounted at the bottom side of foot bracket, etc. Please select the set position of the auto switch so that it does not interfere with the rear plate of the cylinder.

10. Use the cylinder and auto switch in proper combination.

The auto switch is pre-adjusted to activate properly for an auto-switch-capable SMC cylinder. If the auto switch is mounted improperly, used for another brand of cylinder or used after the alternation of the machine installation, the auto switch may not activate properly.

Mounting and Adjustment

⚠ Caution

1. Do not drop or bump.

Do not drop, bump or apply excessive impacts (300 m/s² or more for reed switches and 1000 m/s² or more for solid state switches) while handling. Although the body of the auto switch may not be damaged, the inside of the auto switch could be damaged and cause a malfunction.

2. Mount auto switches using the proper tightening torque.

If an auto switch is tightened beyond the range of tightening torque, the auto switch mounting screws, auto switch mounting brackets or auto switch may be damaged.

On the other hand, tightening below the range of tightening torque may allow the auto switch to slip out of position. (Refer to the auto switch mounting instructions for each series for auto switch mounting, moving, and tightening torque, etc.)

3. Do not carry a cylinder by the auto switch lead wires.

Never carry a cylinder by its lead wires. This may not only cause broken lead wires, but it may cause internal elements of the auto switch to be damaged by the stress.

4. Fix the auto switch with appropriate screw installed on the switch body. If using other screws, auto switch may be damaged.



Series NCM Auto Switches Precautions 3

Be sure to read this before handling.

Wiring

⚠ Caution

1. Confirm proper insulation of wiring.

Be certain that there is no faulty wiring insulation (contact with other circuits, ground fault, improper insulation between terminals, etc.). Damage may occur due to excess current flow into a switch.

2. Do not wire with power lines or high voltage lines.

Wire separately from power lines or high voltage lines, avoiding parallel wiring or wiring in the same conduit with these lines. Control circuits containing auto switches may malfunction due to noise from these other lines.

3. Avoid repeatedly bending or stretching lead wires.

Broken lead wires will result from repeatedly applying bending stress or stretching force to the lead wires. Stress and tensile force applied to the connection between the cable and auto switch increases the possibility of disconnection. Fix the cable in the middle so that it is not movable in the area where it connects with the auto switch.

4. Be sure to connect the load before power is applied.

<2-wire type>

If the power is turned ON when an auto switch is not connected to a load, the auto switch will be instantly damaged because of excess current.

It is the same as when the 2-wire brown cord (+, output) is directly connected to the (+) power supply terminal.

5. Do not allow short circuit of loads.

<Reed switches>

If the power is turned ON with a load in a short circuited condition, the auto switch will be instantly damaged because of excess current flow into the switch.

<Solid state switches>

All models of D-M9□(V) except D-M9□W(V) and G5NB and PNP output type auto switches do not have built-in short circuit protection circuits.

Note that if a load is short circuited, the auto switch will be instantly damaged as in the case of reed switches.

Take special care to avoid reverse wiring with the brown power supply line and the black output line on 3-wire type auto switches.

Wiring

⚠ Caution

6. Avoid incorrect wiring.

<Reed switches>

A 24 VDC auto switch with indicator light has polarity. The brown lead wire or terminal No. 1 is (+), and the blue lead wire or terminal No. 2 is (-).

1) If connections are reversed, an auto switch will operate, however, the light emitting diode will not light up.

Also note that a current greater than that specified will damage a light emitting diode and it will no longer operate.

Applicable model: D-A93, A93V, C73, C73C, B53, B54

2) When using a 2-color indication type auto switch (D-B59W), the auto switch will constantly remain ON if the connections are reversed.

<Solid state switches>

1) If connections are reversed on a 2-wire type auto switch, the auto switch will not be damaged if protected by a protection circuit, but the auto switch will always stay in an ON state. However, it is still necessary to avoid reversed connections, since the auto switch could be damaged by a load short circuit in this condition.

2) If connections are reversed (power supply line + and power supply line -) on a 3-wire type auto switch, the auto switch will be protected by a protection circuit. However, if the power supply line (+) is connected to the blue wire and the power supply line (-) is connected to the black wire, the auto switch will be damaged.

<D-M9□> Applicable to D-M9□(V) prior to July, 2008.

D-M9□ does not have built-in short circuit protection circuit. Be aware that if the power supply connection is reversed (e.g. (+) power supply wire and (-) power supply wire connection is reversed), the auto switch will be damaged.

7. When the cable sheath is stripped, confirm the stripping direction. The insulator may be split or damaged depending on the direction. (D-M9□ only)

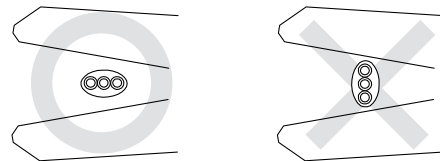

Recommended Tool

Model name	Model no.
Wire stripper	D-M9N-SWY

* Stripper for a round cable (ø2.0) can be used for a 2-wire type cable.

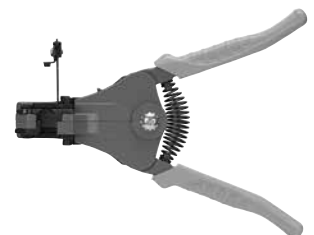



Series NCM Auto Switches Precautions 4

Be sure to read this before handling.

Operating Environment

⚠ Warning

1. Never use in an atmosphere of explosive gases.

The structure of auto switches is not intended to prevent explosion. Never use in an atmosphere with an explosive gas since this may cause a serious explosion.

⚠ Caution

1. Do not use in an area where a magnetic field is generated.

Auto switches will malfunction or magnets inside cylinders will become demagnetized. (Consult SMC regarding the availability of a magnetic field resistant auto switch.)

2. Do not use in an environment where the auto switch will be continually exposed to water.

Although auto switches satisfy IEC standard IP67 construction, do not use auto switches in applications where continually exposed to water splash or spray. Poor insulation or swelling of the potting resin inside auto switches may cause malfunction.

3. Do not use in an environment with oil or chemicals.

Consult SMC if auto switches will be used in an environment with coolant, cleaning solvent, various oils or chemicals. If auto switches are used under these conditions for even a short time, they may be adversely affected by improper insulation, malfunction due to swelling of the potting resin, or hardening of the lead wires.

4. Do not use in an environment with temperature cycles.

Consult SMC if auto switches are used where there are temperature cycles other than normal temperature changes, as there may be adverse effects inside the auto switches.

5. Do not use in an environment where there is excessive impact shock.

<Reed switches>

When excessive impact (300 m/s² or more) is applied to a reed switch during operation, the contact point will malfunction and generate or cut off a signal momentarily (1 ms or less). Consult SMC regarding the need to use a solid state switch depending upon the environment.

6. Do not use in an area where surges are generated.

<Solid state switches>

When there are units (solenoid type lifter, high frequency induction furnace, motor, radio equipment etc.) which generate a large amount of surge in the area around cylinders with solid state auto switches, this may cause deterioration or damage to the auto switch. Avoid sources of surge generation and disorganized lines.

7. Avoid accumulation of iron waste or close contact with magnetic substances.

When a large amount of iron waste such as machining chips or spatter is accumulated, or a magnetic substance (something attracted by a magnet) is brought into close proximity with an auto switch cylinder, it may cause the auto switch to malfunction due to a loss of the magnetic force inside the cylinder.

⚠ Caution

8. Please consult SMC concerning water resistance, elasticity of lead wires, usage at welding sites, etc.

9. Do not use in direct sunlight.

10. Do not mount the product in locations where it is exposed to radiant heat.

Maintenance

⚠ Warning

1. Removal of equipment, and supply/exhaust of compressed air

Before any machinery or equipment is removed, first ensure that the appropriate measures are in place to prevent the fall or erratic movement of driven objects and equipment, then cut off the electric power and reduce the pressure in the system to zero. Only then should you proceed with the removal of any machinery and equipment.

When machinery is restarted, proceed with caution after confirming that appropriate measures are in place to prevent actuators from sudden movement.

⚠ Caution

1. Perform the following maintenance periodically in order to prevent possible danger due to unexpected auto switch malfunction.

1) Secure and tighten auto switch mounting screws.

If screws become loose or the mounting position is dislocated, retighten them after readjusting the mounting position.

2) Confirm that there is no damage to lead wires.

To prevent faulty insulation, replace auto switches or repair lead wires, etc., if damage is discovered.

3) Confirm the lighting of the green light on the 2-color indicator type auto switch.

Confirm that the green LED is on when stopped at the established position. If the red LED is on, the mounting position is not appropriate. Readjust the mounting position until the green LED lights up.



www.smctech.com

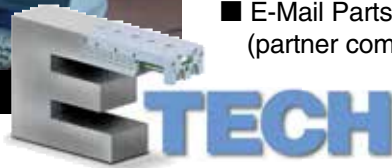

Key Features

- Access E-Tech at www.smctech.com.
- Multiple methods of Product Selection.
- Part Number Validation.
- Preview and download 2D & 3D CAD Models online with real-time updating.
- Save Parts into a custom Parts List.
- E-Mail Parts Lists to internal groups (purchasing, maintenance) or external (partner companies, SMC sales representative).

Product Selection

Browse Catalog

- Allows user to select products based on visual representation.
- For use when "I know what I'm looking for, I just don't know the part number".



Direct Entry

- Fastest method to select product.
- Partial part numbers or full part numbers can be entered.
- Automatically sets drop down options on configuration page.



Part Number Validation

- Use Pull-Downs to make selections and "build" the part number.
- The part number is validated:
 - ~ **Partial** indicates that additional entries are needed.



Invalid indicates that there is a conflict between two or more values. Conflicting values are shown in red. 4 Valid part numbers can be ordered and downloaded as CAD files.

Parts List

- Select "**Save Part**" to add the part to your personal Parts List.
- When you return to the site, your Parts List will contain all saved parts.

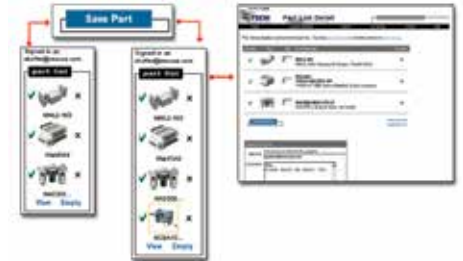

CAD Functions

- Preview and download online 2D & 3D CAD. Preview parts online using a free ActiveX browser applet which auto-installs the first time this function is used.
- The preview model matches the specified part you have configured and validated.



Global Manufacturing, Distribution and Service Network

Worldwide Subsidiaries

EUROPE

AUSTRIA
SMC Pneumatik GmbH (Austria)

BELGIUM
SMC Pneumatics N.V./S.A.

BULGARIA
SMC Industrial Automation Bulgaria EOOD

CROATIA
SMC Industrijska Automatika d.o.o.

CZECH
SMC Industrial Automation CZ s.r.o.

DENMARK
SMC Pneumatik A/S

ESTONIA
SMC Pneumatics Estonia

FINLAND
SMC Pneumatics Finland OY

FRANCE
SMC Pneumatique S.A.

GERMANY
SMC Pneumatik GmbH

GREECE
SMC Hellas EPE

HUNGARY
SMC Hungary Ipari Automatizálási Kft.

IRELAND
SMC Pneumatics (Ireland) Ltd.

ITALY
SMC Italia S.p.A.

LATVIA
SMC Pneumatics Latvia SIA

LITHUANIA
SMC Pneumatics Lietuva, UAB

NETHERLANDS
SMC Pneumatics BV

NORWAY
SMC Pneumatics Norway A/S

POLAND
SMC Industrial Automation Polska Sp.z.o.o.

ROMANIA
SMC Romania S.r.l.

RUSSIA
SMC Pneumatik LLC.

SLOVAKIA
SMC Priemyselná Automatizácia, s.r.o.

SLOVENIA
SMC Industrijska Avtomatika d.o.o.

SPAIN / PORTUGAL
SMC España, S.A.

SWEDEN
SMC Pneumatics Sweden AB

SWITZERLAND
SMC Pneumatik AG

UK
SMC Pneumatics (U.K.) Ltd.

ASIA

CHINA
SMC (China) Co., Ltd.

HONG KONG
SMC Pneumatics (Hong kong) Ltd.

INDIA
SMC Pneumatics (India) Pvt. Ltd.

JAPAN
SMC Corporation

MALAYSIA
SMC Pneumatics (S.E.A.) Sdn. Bhd.

PHILIPPINES
SMC Pneumatics (Philippines), Inc.

SINGAPORE
SMC Pneumatics (S.E.A.) Pte. Ltd.

SOUTH KOREA
SMC Pneumatics Korea Co., Ltd.

TAIWAN
SMC Pneumatics (Taiwan) Co., Ltd.

THAILAND
SMC Thailand Ltd.

NORTH AMERICA

CANADA
SMC Pneumatics (Canada) Ltd.

MEXICO
SMC Corporation (Mexico) S.A. DE C.V.

USA
SMC Corporation of America

SOUTH AMERICA

ARGENTINA
SMC Argentina S.A.

BOLIVIA
SMC Pneumatics Bolivia S.R.L.

BRAZIL
SMC Pneumaticos do Brazil Ltda.

CHILE
SMC Pneumatics (Chile) S.A.

PERU
SMC Corporation Peru S.A.C.

VENEZUELA
SMC Neumatica Venezuela S.A.

OCEANIA

AUSTRALIA
SMC Pneumatics (Australia) Pty. Ltd.

NEW ZEALAND
SMC Pneumatics (N.Z.) Ltd.

U.S. & Canadian Sales Offices

WEST

Austin
Dallas
Los Angeles
Phoenix
Portland
San Jose

CENTRAL

Chicago
Cincinnati
Cleveland
Detroit
Des Moines
Grand Rapid
Indianapolis
Kansas
Milwaukee
Minneapolis
St. Louis

EAST

Albany
Atlanta
Boston
Charlotte
Nashville
New Jersey
Rochester
Tampa

CANADA

Vancouver
Toronto
Windsor
Montreal

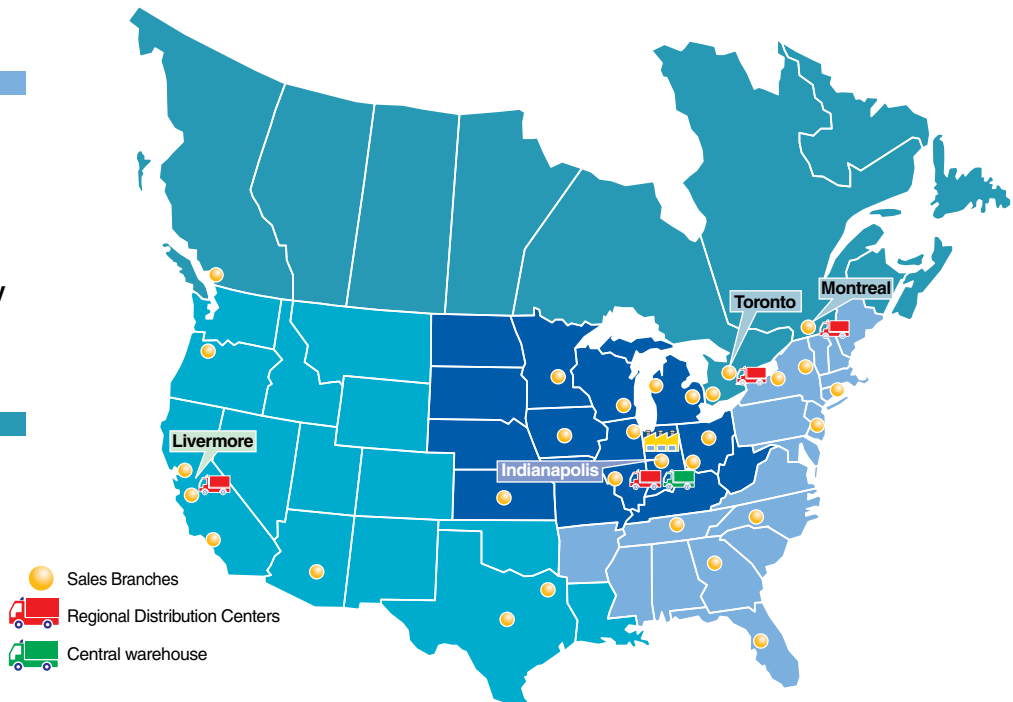

SMC Corporation of America
10100 SMC Blvd., Noblesville, IN 46060
www.smcusa.com

SMC Pneumatics (Canada) Ltd.
www.smc Pneumatics.ca

(800) SMC.SMC1 (762-7621)
e-mail: sales@smcusa.com
International inquiries: www.smcworld.com





Series NCM–X6009

All Stainless Steel Cylinder



- All exterior components made from corrosion resistant 304 stainless steel
- Built in rod wiper to protect interior from contaminants
- Same built-in quality features as standard NCM Series
- Available in 6 bore sizes
- Rod cover wrench flats for safer cylinder tightening
- Dimensionally interchangeable with standard NCM Series

Construction Features

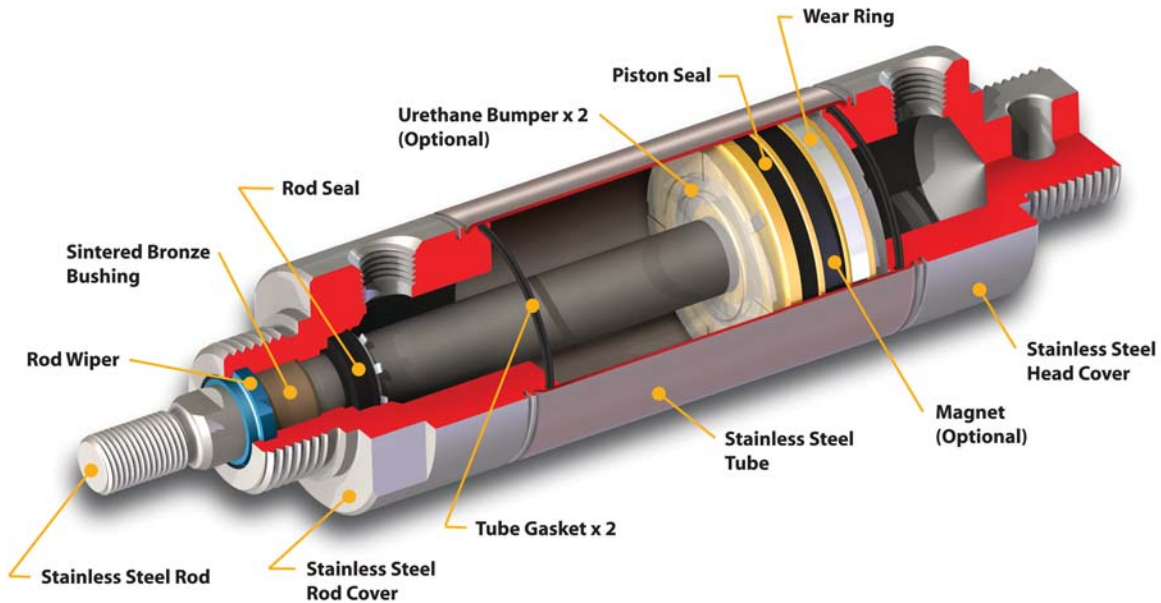

Specifications

Bore Size (Inch)	075 (3/4")	088 (7/8")	106 (1-1/16")	125 (1.25")	150 (1.5")	200 (2")
Fluid	Air					
Maximum Operating Pressure	250 PSI (1.7MPa)					150 PSI (1.0 MPa)
Minimum Operating Pressure	8 PSI (0.06MPa)					
Ambient and Fluid Temperature	40° to 140° F					
Piston Speed	No bumper: 2 to 20 inch/sec (50 to 500 mm/sec) Bumper: 2 to 30 inch/sec (50 to 750 mm/sec)					
Cushion	Urethane bumper optional					
Lubrication	Not required (Pre-lubricated at factory with standard or food grade grease)					
Mounting	B, E					

How to Order

NC **D** **M** **B** **075** - **02** **00** **C** - **M9NA** ***** - **X6009**

Auto switch magnet

Nil	No magnet
D	A/S Capable

• Magnet not available with XB6 and XB7.

Mounting style

B	Front nose mount
E	Double end

Note) "E" mount includes rear clevis hole but does not include clevis pin or mounting.

Bore Size

075	3/4"
088	7/8"
106	1-1/16"
125	1-1/4"
150	1-1/2"
200	2"

Stroke/Inch

Stroke/Hundredths of an inch

Options

X6009	All stainless steel with standard grease
X6009A	Food grade grease
X6009B	Food grade grease & viton wiper/rod seal
X6009C	Food grade grease & all viton seals
XB6-X6009*	High temp. and stainless
XB7-X6009*	Low temp. and stainless

* XB6-X6009 contains XB6 seals and grease. XB7-X6009 contains standard XB7 seals and grease.

Number of auto switches

Nil	2 pcs.
S	1 pc.
n	"n" pcs.
L	Long leads

Auto switch

Nil	Without auto switch
M9NA	3 wire NPN
M9PA	3 wire PNP
M9BA	2 wire

• See auto switch How-To-Order

Note) There are other applicable auto switches than listed, contact SMC for details.

Cushion

Nil	None
C	Urethane

• Cushion not available in combination with XB6 or XB7

NCM -X6009 Accessories

Stainless Steel Foot Bracket

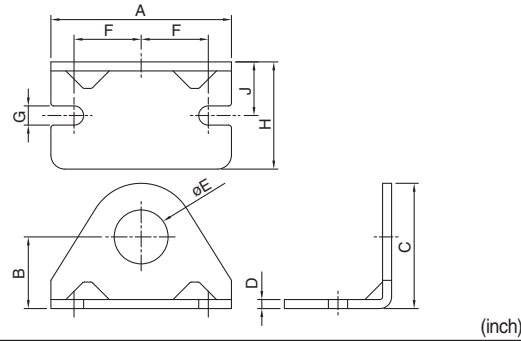

Part no.	Applicable bore size	A	B	C	D	E	F	G	H	J
NCM-L075SS	3/4", 7/8", 1-1/16"	1.89	0.81	1.36	0.12	0.63	0.75	0.27	0.98	0.56
NCM-L150SS	1-1/4", 1-1/2"	2.52	1.00	1.75	0.12	0.75	0.94	0.27	1.50	0.75
NCM-L200SS	2"	3.12	1.50	2.50	0.25	1.38	1.13	0.34	1.63	1.00

Stainless Steel Rod Clevis

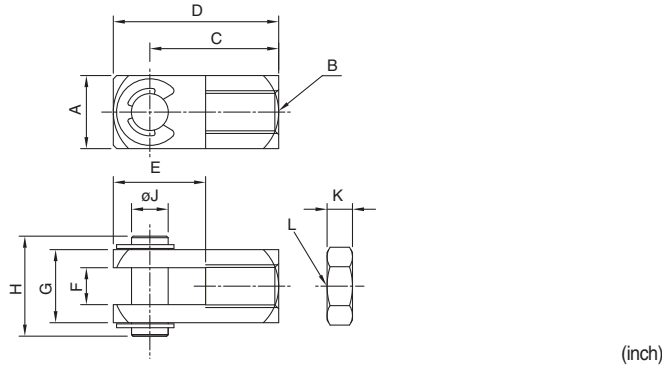

Part no.	Applicable bore size	A	B	C	D	E	F	G	H	J	K	L
NY-075SS	3/4", 7/8"	0.51	1/4-28	0.94	1.18	0.69	0.25	0.51	0.71	0.25	0.16	1/4-28
NY-106SS	1-1/16"	0.51	5/16-24	0.94	1.18	0.69	0.25	0.51	0.71	0.25	0.19	5/16-24
NY-125SS	1-1/4", 1-1/2"	0.75	7/16-20	1.31	1.69	0.94	0.38	0.75	1.02	0.38	0.25	7/16-20
NY-G050SS	2"	0.75	1/2-20	1.32	1.69	0.94	0.38	0.75	1.02	0.38	0.31	1/2-20

Stainless Jam Nut (Rod Thread)

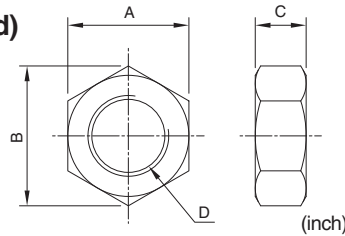

Part no.	Applicable bore size	A	B	C	D
JM-025-SUS	3/4", 7/8"	0.44	0.51	0.16	1/4-28 UNF
JM-03-SUS	1-1/16"	0.50	0.50	0.19	5/16-24 UNF
JM-045-SUS	1-1/4", 1-1/2"	0.69	0.79	0.26	7/16-20 UNF
JM-05-SUS <small>Note 1)</small>	2"	0.75	0.87	0.32	1/2-20 UNF

Note 1) Please order separately.

Stainless Steel Mounting Nut (Nose Mount Thread)

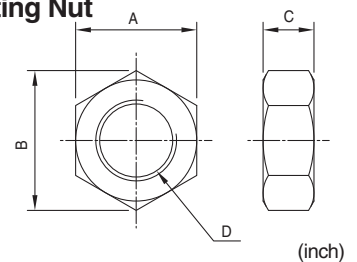

Part no.	Applicable bore size	A	B	C	D
JM-08-SUS	3/4", 7/8" 1-1/16"	0.94	1.08	0.38	5/8-18 UNF
JM-10-SUS	1-1/4", 1-1/2"	1.12	1.30	0.42	3/4-16 UNF
JM-14-SUS	2"	1.61	1.86	0.43	1-1/4 -12 UNF

Stainless Steel Pivot Bracket

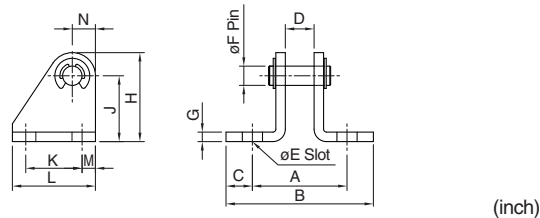

Part no.	Applicable bore size	A	B	C	D	øE	F	G	H	J	K	L	M	N	Pin Part No.	Retaining Ring Part No.
NCM-PE075SS	3/4", 7/8" 1-1/16"	1.25	1.95	0.35	0.38	0.27	0.25	0.12	1.18	0.88	0.75	1.10	0.18	0.31	NCM075-23A-X6009	98408A120
NCM-PE125SS	1-1/4"	1.38	2.08	0.35	0.50	0.27	0.25	0.12	1.18	0.88	0.75	1.10	0.18	0.31	NCM125-23A-X6009	98408A120
NCM-PE150SS	1-1/2"	1.88	2.63	0.36	0.63	0.27	0.38	0.12	1.75	1.38	1.00	1.50	0.25	0.37	NCM150-23-X6009	98408A134
NCG-PC050SS	2"	2.12	3.00	0.44	0.75	0.26	0.38	0.24	1.75	1.38	1.00	1.50	0.25	0.37	NCM200-23-X6009	98408A134

Related Product

Water Resistant 2-Color Indication Solid State Switch: Direct Mounting Style How to Order

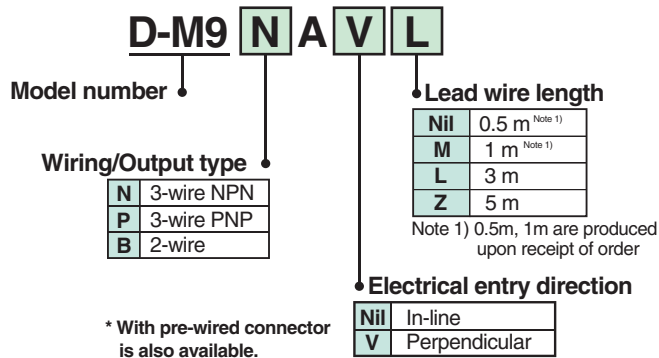

- Water (coolant) resistant type
- 2-wire load current is 2.5 to 40 mA
- RoHS compliant
- UL certified (style 2844) lead cable is used



Global Manufacturing, Distribution and Service Network

Worldwide Subsidiaries

EUROPE

AUSTRIA
SMC Pneumatik GmbH (Austria)

BELGIUM
SMC Pneumatics N.V./S.A.

BULGARIA
SMC Industrial Automation Bulgaria EOOD

CROATIA
SMC Industrijska Automatika d.o.o.

CZECH
SMC Industrial Automation CZ s.r.o.

DENMARK
SMC Pneumatik A/S

ESTONIA
SMC Pneumatics Estonia

FINLAND
SMC Pneumatics Finland OY

FRANCE
SMC Pneumatique S.A.

GERMANY
SMC Pneumatik GmbH

GREEK
SMC Hellas EPE

HUNGARY
SMC Hungary Ipari Automatizálási Kft.

IRELAND
SMC Pneumatics (Ireland) Ltd.

ITALY
SMC Italia S.p.A.

LATVIA
SMC Pneumatics Latvia SIA

LIETUVA
SMC Pneumatics Lietuva, UAB

NETHERLANDS
SMC Pneumatics BV

NORWAY
SMC Pneumatics Norway A/S

POLAND
SMC Industrial Automation Polska Sp.z.o.o.

ROMANIA
SMC Romania S.r.l.

RUSSIA
SMC Pneumatik LLC.

SLOVAKIA
SMC Priemyselna Automatizácia, s.r.o.

SLOVENIA
SMC Industrijska Avtomatika d.o.o.

SPAIN/PORTUGAL
SMC España, S.A.

SWEDEN
SMC Pneumatics Sweden AB

SWITZERLAND
SMC Pneumatik AG

UK
SMC Pneumatics (U.K.) Ltd.

ASIA

CHINA
SMC (China) Co., Ltd.

HONG KONG
SMC Pneumatics (Hong kong) Ltd.

INDIA
SMC Pneumatics (India) Pvt. Ltd.

JAPAN
SMC Corporation

MALAYSIA
SMC Pneumatics (S.E.A.) Sdn. Bhd.

PHILIPPINES
SMC Pneumatics (Philippines), Inc.

SINGAPORE
SMC Pneumatics (S.E.A.) Pte. Ltd.

SOUTH KOREA
SMC Pneumatics Korea Co., Ltd.

TAIWAN
SMC Pneumatics (Taiwan) Co., Ltd.

THAILAND
SMC Thailand Ltd.

NORTH AMERICA

CANADA
SMC Pneumatics (Canada) Ltd.

MEXICO
SMC Corporation (Mexico) S.A. DE C.V.

USA
SMC Corporation of America

SOUTH AMERICA

ARGENTINA
SMC Argentina S.A.

BOLIVIA
SMC Pneumatics Bolivia S.R.L.

BRAZIL
SMC Pneumaticos do Brazil Ltda.

CHILE
SMC Pneumatics (Chile) S.A.

VENEZUELA
SMC Neumatica Venezuela S.A.

OCEANIA

AUSTRALIA
SMC Pneumatics (Australia) Pty. Ltd.

NEW ZEALAND
SMC Pneumatics (N.Z.) Ltd.

U.S. & Canadian Sales Offices

EAST	WEST	MIDWEST	CANADA
Atlanta	Austin	Chicago	Calgary
Boston	Dallas	Cincinnati	Montreal
Charlotte	Los Angeles	Cleveland	Toronto
Nashville	Phoenix	Detroit	Vancouver
New Jersey	Portland	Indianapolis	Windsor
Richmond	San Francisco	Milwaukee	
Rochester		Minneapolis	
Tampa		St. Louis	

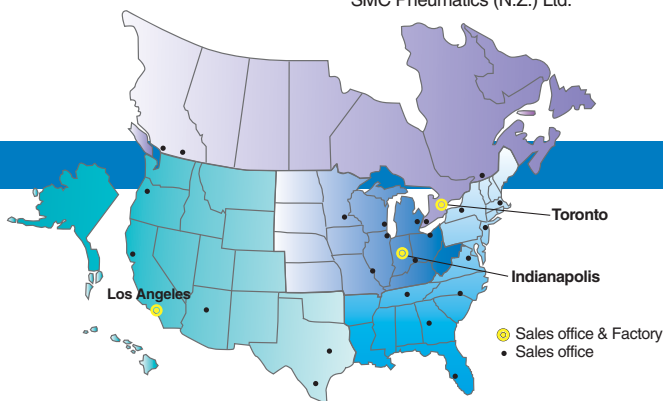

SMC Corporation of America
3011 N. Franklin Road
Indianapolis, IN 46226

(800) SMC.SMC1 (762-7621)

www.smcusa.com

SMC Pneumatics (Canada) Ltd.
6768 Financial Drive Mississauga
Ontario, L5N 7J6 Canada

www.smc Pneumatics.ca

For international inquiries: www.smcworld.com