



## Servo-assisted 2/2 way diaphragm valve

- Servo-assisted diaphragm with diameter of up to DN50
- Vibration-proof, central screwed coil system
- Damped design for quiet closing
- Service-friendly manual override
- Explosion-proof versions



Product variants described in the data sheet may differ from the product presentation and description.

### Can be combined with



**Type 2518**  
 Cable Plug  
 DIN EN 175301 - 803 -  
 Form A

### Type description

The 6281 valve is a servo-assisted solenoid valve of the S.EV series. A minimum differential pressure is always required for the function of the valve. Various diaphragm material combinations and methods of operation are available depending on the application. The standard brass housing satisfies all European drinking water requirements. Dezincification-resistant brass is available for other markets. The housing offering is rounded out by a stainless steel version. For reduced energy requirement, all coils can be delivered with electronic power reduction. The valve can be equipped with manual override for easy maintenance and commissioning. In combination with a plug in accordance with DIN EN 175301 - 803 Form A, the valves satisfy protection class IP65 – in combination with a stainless steel housing NEMA 4X.

## Table of contents

<b>1. General Technical Data</b>	<b>3</b>
<b>2. Circuit functions</b>	<b>3</b>
<b>3. Approvals</b>	<b>4</b>
<b>4. Materials</b>	<b>4</b>
4.1. Chemical Resistance Chart – Bürkert resistApp.....	4
4.2. Material specifications standard version .....	4
<b>5. Dimensions</b>	<b>5</b>
5.1. Standard version.....	5
5.2. ATEX version with cable connection.....	7
5.3. ATEX version with terminal box .....	8
5.4. Compressor relief valves .....	9
<b>6. Performance specifications</b>	<b>10</b>
6.1. Power consumption .....	10
<b>7. Product accessories</b>	<b>10</b>
7.1. Cable glands for ATEX/IECEX terminal box .....	10
7.2. Special tool to turn the terminal box.....	10
<b>8. Ordering information</b>	<b>11</b>
8.1. Bürkert eShop – Easy ordering and quick delivery.....	11
8.2. Bürkert product filter.....	11
8.3. Ordering chart.....	11
Standard version with brass body .....	11
Standard version with stainless steel body .....	13
Explosion proofed version ATEX and IECEX, electrical connection with 3 m cable .....	14
Explosion proofed version ATEX and IECEX, electrical connection with terminal box.....	15
Compressor relief valve with brass body.....	16
8.4. Ordering chart accessories.....	16
Cable plug Type 2513, form A acc. to DIN EN 175301-803 .....	16
Cable plug Type 2518, Form A according to DIN EN 175301-803 .....	17
Cable glands for ATEX/IECEX terminal box .....	17

## 1. General Technical Data

Product properties	
Dimensions	Detailed information can be found in chapter <b>"5. Dimensions"</b> on page 5.
Material	
Body	Brass acc. to DIN EN 50930-6, stainless steel (dezincification resistant on request)
Inner valve parts	Stainless steel, Brass, Plastic (PPS)
Seal	NBR, EPDM, FKM
Nominal diameter	DN10...DN50
Thermal insulation class of solenoid	Polyamide class B Epoxy class H
Performance data	
Duty cycle	100 % continuous rating
Response times <sup>1.)</sup>	0.1...4 sec. (depending on orifice and differential pressure)
Electrical data	
Voltage tolerance	± 10 %
Operating voltage	024/DC, 024/UC, 024/50...60 V/Hz, 230/UC, 230/50...60 V/Hz
Electrical connection	Tag connector acc. to DIN EN 175301-803 Form A for cable plug Type 2518 (see <b>"8.4. Ordering chart accessories"</b> on page 16)
Media data	
Media	
NBR	Neutral fluids, e.g. compressed air, water
EPDM	Oil and fat-free fluids, hot water, acetone, aqueous alkali solution
FKM	Hot air, per-solution
Medium temperature	
NBR	-10 °C... +80 °C
EPDM	-30 °C... +90 °C (with epoxy coil to +100 °C)
FKM	0 °C... +90 °C (with epoxy coil to +120 °C)
Approvals and certificates	
Directives	CE, EAC
Environment and installation	
Installation	As required, preferably with actuator upright
Degree of protection	IP65 with cable plug, cable connection and terminal box
Ambient temperature (max.)	+55 °C

1.) Measured at valve outlet at 6 bar and +20 °C. Opening: pressure build-up 0...90 %, Closing: pressure decay 100...10 %.

## 2. Circuit functions

Circuit functions	Description
	<b>Type: A, solenoid valve</b> 2/2 way Servo-controlled Normally closed
	<b>Type: B, solenoid valve</b> 2/2 way Servo-controlled Normally opened

### 3. Approvals

Explosion-proof approvals	
ATEX: EPS 18 ATEX 1232 X II 2G Ex mb IIC T4 Gb II 2D Ex mb IIIC T130 °C Db II 2G Ex eb mb IIC T4 Gb II 2D Ex mb tb IIIC T130 °C Db	IECEX: IECEX EPS 18.0110 X Ex mb IIC T4 Gb Ex mb IIIC T130 °C Db Ex eb mb IIC T4 Gb Ex mb tb IIIC T130 °C Db

### 4. Materials

#### 4.1. Chemical Resistance Chart – Bürkert resistApp



#### Bürkert resistApp – Chemical Resistance Chart

You want to ensure the reliability and durability of the materials in your individual application case? Verify your combination of media and materials on our website or in our resistApp.

[Start Chemical Resistance Check](#)

#### 4.2. Material specifications standard version

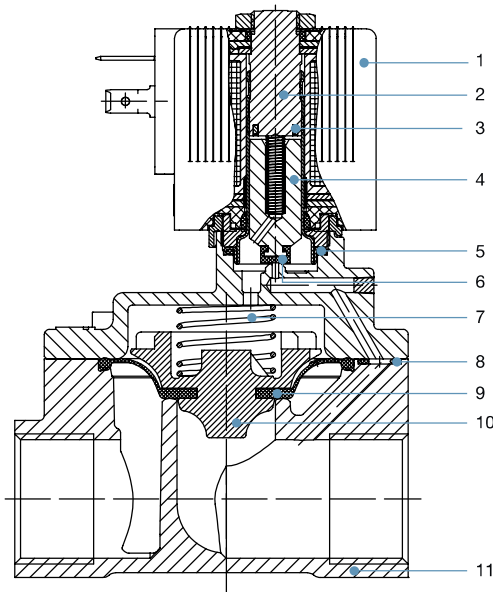

No.	Element	Material
1	Coil	Polyamide <sup>1.)</sup> or Epoxy <sup>2.)</sup>
2	Stopper	1.4113
3	Shading ring	Cu (brass version) Ag (stainless steel version)
4	Magnetic core	1.4113
5	O-rings	NBR, FKM, EPDM
6	Core seal	NBR, FKM, EPDM
7	Spring	1.4310
8	O-rings	NBR, FKM, EPDM
9	Diaphragm	NBR, FKM, EPDM
10	Diaphragmholder	PPSGF40, DN50: Brass and stainless steel
11	Valve body	Brass, conforming to DIN 50930-6 or stainless steel 1.4408 (CF8M)

1.) With NBR/EPDM seal

2.) With FKM seal

DTS 1000152082 EN Version: N Status: RL (released | freigegeben | validé) printed: 06.04.2021

## 5. Dimensions

### 5.1. Standard version

**Note:**

- Dimensions in mm
- The dimensions F1 and G1 apply to G-threads
- The dimensions F2 and G2 apply to NPT-threads
- The dimensions F3 and G3 apply to Rc-threads

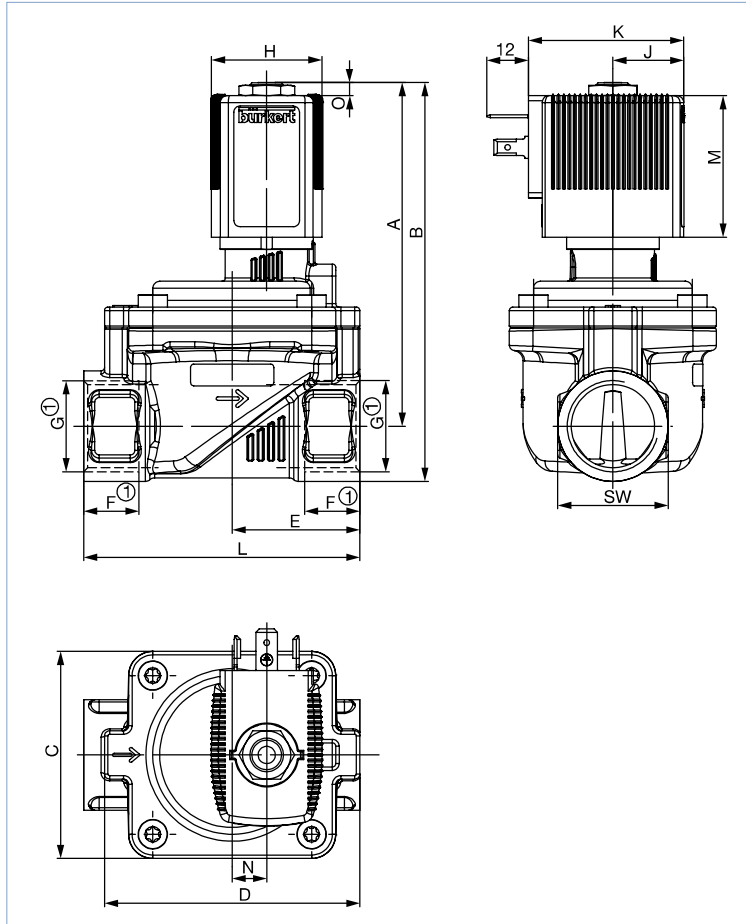

Coil size	H	J	K	M	O
5	32	20.5	45	41	3.4
6	40	23.5	51	41.4	3.8

DTS 1000152082 EN Version: N Status: RL (released | freigegeben | validé) printed: 06.04.2021

DN	A	B	C	D	E	G		NPT		Rc		L	SW	N
						F1	G1	F2	G2	F3	G3			
10 <sup>1)</sup>	83.1	94.1	32	44	22	12	G ¼	10	NPT ¼	-	-	50	22	-
						12	G ⅜	10.3	NPT ⅜	10.1	Rc ⅜			
10 <sup>2)</sup>	85.1	98.6	32	44	24.5	14	G ½	13.7	NPT ½	-	-	50	27	-
						22	G ¼	10	NPT ¼	-	-			
13 <sup>1)</sup>	83.6	94.6	42	54.5	22	12	G ¼	10	NPT ¼	-	-	50	22	-
						12	G ⅜	10.3	NPT ⅜	10.1	Rc ⅜			
13	85.6	99.1	42	54.5	24.5	14	G ½	13.7	NPT ½	-	-	55	27	-
						22	G ¼	10	NPT ¼	-	-			
20	91.1	104.6	60	74	27.25	12	G ⅝	-	-	-	-	58	27	-
						32.5	G ½	13.7	NPT ½	13.2	Rc ½			
25	93.1	109.1	70	85	37	14	G ¾	14	NPT ¾	-	-	65	32	10
						16	G ¾	14	NPT ¾	-	-			
25	99.6	115.6	70	85	37	16	G ¾	14	NPT ¾	14.5	Rc ¾	80	32	10
						18	G 1	16.8	NPT 1	-	-			
25	102.1	122.6	70	85	46	16	G ¾	14	NPT ¾	14.5	Rc ¾	80	32	10
						18	G 1	16.8	NPT 1	-	-			
25	106.6	127.1	70	85	46	18	G 1	16.8	NPT 1	16.8	Rc 1	95	41	15
						20	G 1¼	17.3	NPT 1¼	19.1	Rc 1¼			
25	111.6	136.6	70	85	46	18	G 1	16.8	NPT 1	16.8	Rc 1	95	41	15
						20	G 1¼	17.3	NPT 1¼	19.1	Rc 1¼			

DN	A	B	C	D	E	G		NPT		Rc		L	SW	N
						F1	G1	F2	G2	F3	G3			
40 <sup>1.)</sup>	120.1	145.1	99	114	61	20	G 1¼	17.3	NPT 1¼	19.1	Rc 1¼	126	50	23
40	125.6	155.6			22	G 1½		NPT 1½		Rc 1½	126	60		
	131.6	166.6			64	G 2	17.6	NPT 2	23.4	Rc 2	132	70		
50 <sup>1.)</sup>	119.9	154.9	115	132	82	24	G 2	17.6	NPT 2	23.4	Rc 2	164	70	37
	119.6	162.1			89.5	27	G 2½	23.6	NPT 2½	–	–	179	85	

1.) Only brass threaded port version

2.) Only stainless steel threaded port version

5.2. ATEX version with cable connection

Note:

- Dimensions in mm
- The dimensions F1 and G1 apply to G-threads
- The dimensions F2 and G2 apply to NPT-threads
- The dimensions F3 and G3 apply to RC-threads
- For DN50 see dimensions "5.3. ATEX version with terminal box" on page 8

DTS 1000152082 EN Version: N Status: RL (released | freigegeben | validé) printed: 06.04.2021

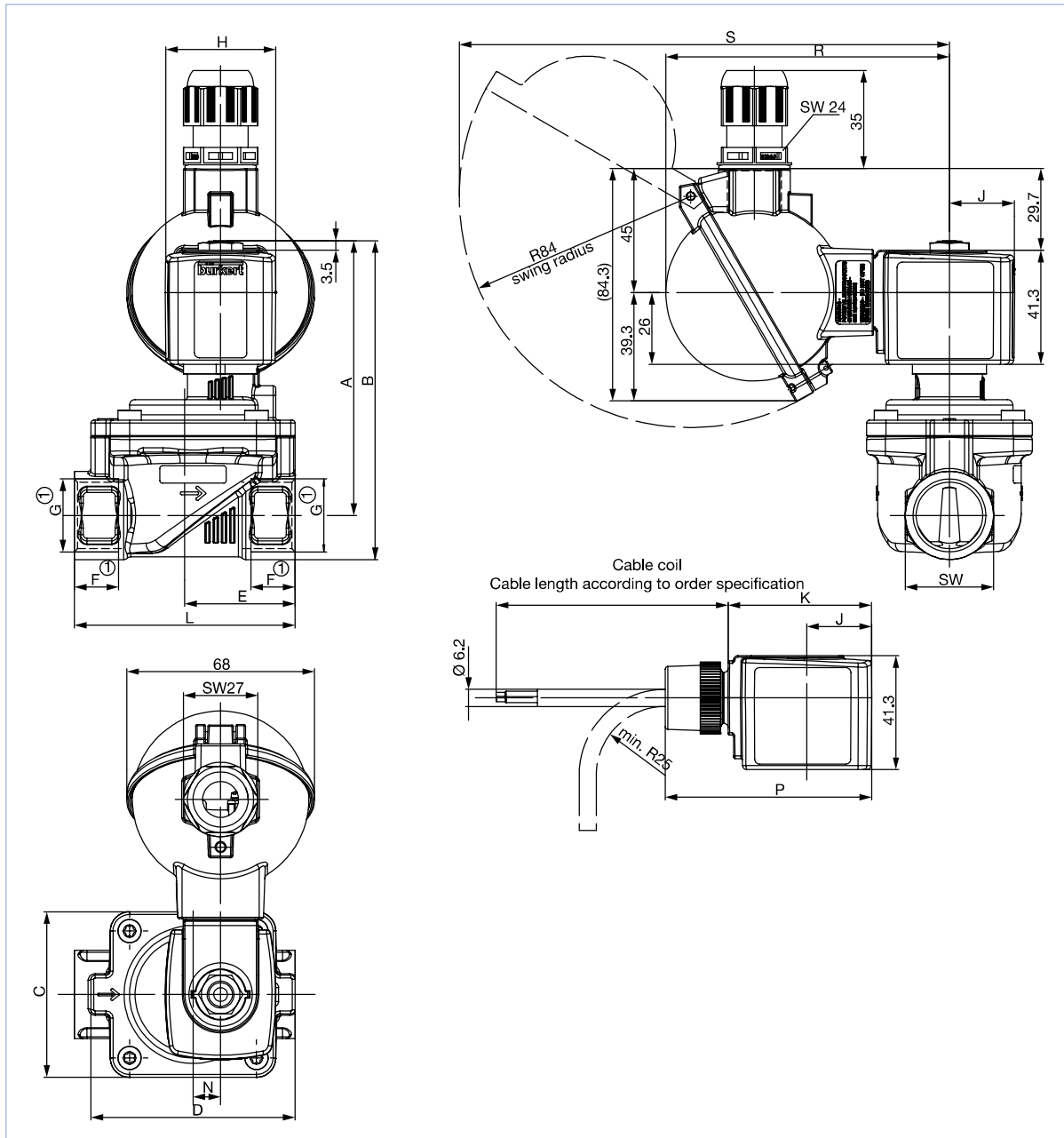

Coil size	H	J	K	P	R	S
5	32	20.5	46	68.8	99.8	174.7
6	40	23.5	52	74.8	103	177.7

DN	A	B	C	D	E	G		NPT		Rc		L	SW	N
						F1	G1	F2	G2	F3	G3			
10 <sup>1,2</sup>	83.1	94.1	32	44	22	12	G ¼	10	NPT ¼	-	-	50	22	-
						12	G ⅜	10.3	NPT ⅜	10.1	Rc ⅜			
10 <sup>2,1</sup>	85.1	98.6	32	44	24.5	14	G ½	13.7	NPT ½	-	-	50	27	-
						12	G ⅜	10.3	NPT ⅜	10.1	Rc ⅜			
10 <sup>2,2</sup>	83.6	94.6	32	44	22	12	G ¼	10	NPT ¼	-	-	50	22	-
						12	G ⅜	10.3	NPT ⅜	10.1	Rc ⅜			
13 <sup>1,2</sup>	91.1	104.6	42	54.5	27.25	12	G ⅜	-	-	-	-	58	27	-
						14	G ½	13.7	NPT ½	13.2	Rc ½			
13	93.1	109.1	42	54.5	32.5	16	G ¾	14	NPT ¾	-	-	65	32	-
						18	G 1	16.8	NPT 1	-	-			
20	99.6	115.6	60	74	37	16	G ¾	14	NPT ¾	14.5	Rc ¾	80	32	10
						18	G 1	16.8	NPT 1	-	-			
25	106.6	127.1	70	85	46	18	G 1	16.8	NPT 1	16.8	Rc 1	95	41	15
						20	G 1¼	17.3	NPT 1¼	19.1	Rc 1¼			
40 <sup>1,2</sup>	120.1	145.1	99	114	61	20	G 1¼	17.3	NPT 1¼	19.1	Rc 1¼	126	50	23
						22	G 1½	-	NPT 1½	-	Rc 1½			
40	125.6	155.6	99	114	64	24	G 2	17.6	NPT 2	23.4	Rc 2	132	70	-
						27	G 2½	23.6	NPT 2½	-	-			
50 <sup>1,2</sup>	119.9	154.9	115	132	82	24	G 2	17.6	NPT 2	23.4	Rc 2	164	70	37
						27	G 2½	23.6	NPT 2½	-	-			
	119.6	162.1			89.5	27	G 2½	23.6	NPT 2½	-	-	179	85	

### 5.3. ATEX version with terminal box

**Note:**

- Dimensions in mm
- Standard at DN50

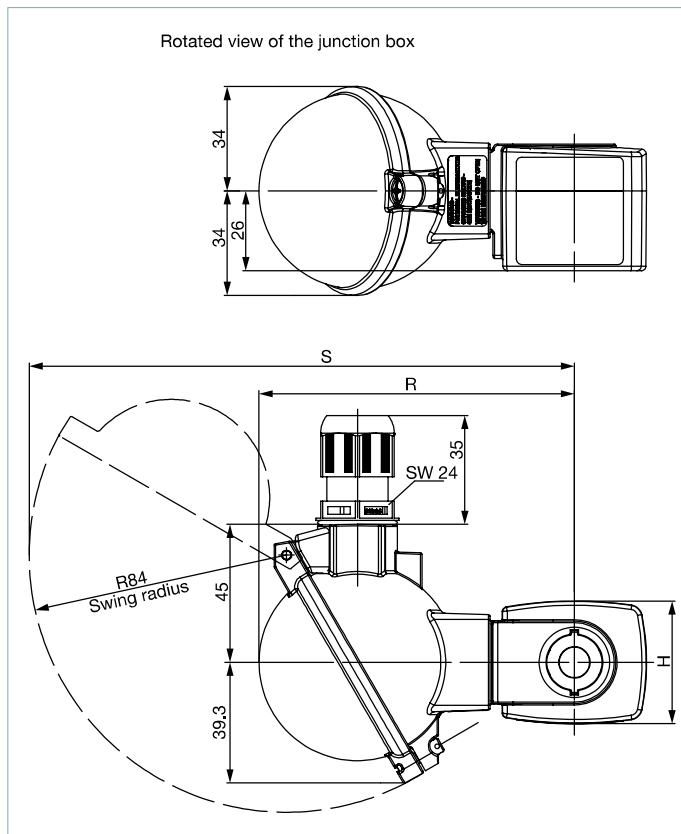

Coil size	H	J	K	P	R	S
5	32	20.5	46	68.8	99.8	174.7
6	40	23.5	52	74.8	103	177.7

DTS 1000152082 EN Version: N Status: RL (released | freigegeben | validé) printed: 06.04.2021



### 5.4. Compressor relief valves

**Note:**

- Dimensions in mm
- The dimensions F1 and G1 apply to G-threads
- The dimensions F2 and G2 apply to NPT-threads
- The dimensions F3 and G3 apply to RC-threads

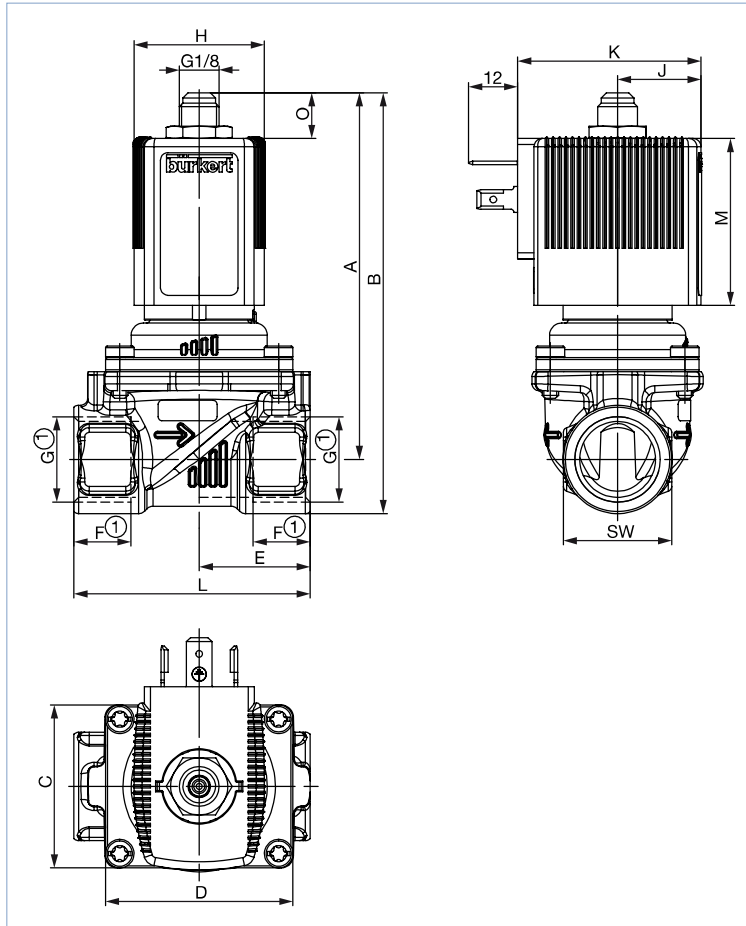

Coil size	H	J	K	M	O
5	32	20.5	46	41	11.2
6	40	23.5	52	41.4	10.8

DTS 1000152082 EN Version: N Status: RL (released | freigegeben | validé) printed: 06.04.2021

DN	A	B	C	D	E	G		NPT		Rc		L	SW
						F1	G1	F2	G2	F3	G3		
10	90.5	101.5	32	44	22	12	G 1/4	10	NPT 1/4	-	-	50	22
	92.5	106				12	G 3/8	10.3	NPT 3/8	10.1	Rc 3/8		27
13	90	103.5	42	54.5	27.25	14	G 1/2	13.7	NPT 1/2	13.2	Rc 1/2	58	27
	92	108				14	G 1/2	13.7	NPT 1/2	13.2	Rc 1/2		
20	107	123	60	74	37	16	G 3/4	14	NPT 3/4	14.5	Rc 3/4	80	32
	109.5	130				16	G 3/4	14	NPT 3/4	14.5	Rc 3/4		32
					37.5	18	G 1	16.8	NPT 1	-	-		41

## 6. Performance specifications

### 6.1. Power consumption



Orifice [mm]	Circuit function	Coil size [mm]	AC			DC		ATEX AC/DC
			Inrush power [VA]	Holding power [VA] [W]		Cold power [W]	Warm power [W]	Nominal power [W]
10...50	WWA	32	24	14	8	9,5	8	–
10...50	WWB	32	24	16	7	9,5	8	–
13...50	WWA / WWB	40	–	–	–	–	–	9
10	WWA	32	–	–	–	–	–	7
10	WWB	40	–	–	–	–	–	9
10	WWB u. CF05	32	18	11	5	6	5	–
13	WWB u. MX62	32	24	14	8	–	–	–
13	WWB u. MX62	40	–	–	–	11	9,5	–

## 7. Product accessories

### 7.1. Cable glands for ATEX/IECEX terminal box

#### Note:

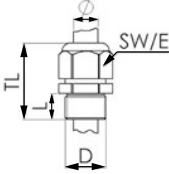
- A cable gland in polyamide version is included in the delivery. A nickel-plated brass version can be ordered at a surcharge.
- This special tool is not supplied with the valve (see “8.4. Ordering chart accessories” on page 16).

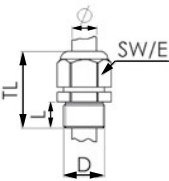
Description	Ex approvals		Dimensions										
	Certification	Identification											
Ex cable gland, Brass, nickelplated, 6...13 mm 	PTB 04 ATEX 1112 X, IECEX PTB 13.0027X	II 2 G Ex e IIC Gb, II 2 D Ex tb IIIC Db IP68	 <table border="1"> <tr><td>TL</td><td>29...37 mm</td></tr> <tr><td>L</td><td>6 mm</td></tr> <tr><td>D</td><td>20 mm</td></tr> <tr><td>SW</td><td>24 mm</td></tr> <tr><td>E</td><td>27 mm</td></tr> </table>	TL	29...37 mm	L	6 mm	D	20 mm	SW	24 mm	E	27 mm
TL	29...37 mm												
L	6 mm												
D	20 mm												
SW	24 mm												
E	27 mm												
Ex cable gland, Polyamide, 7...13 mm 	PTB 13 ATEX 1015 X, IECEX PTB 13.0034X	II 2 G Ex e IIC Gb, II 2 D Ex tb IIIC Db IP68	 <table border="1"> <tr><td>TL</td><td>36...45 mm</td></tr> <tr><td>L</td><td>10 mm</td></tr> <tr><td>D</td><td>20 mm</td></tr> <tr><td>SW</td><td>24 mm</td></tr> <tr><td>E</td><td>28 mm</td></tr> </table>	TL	36...45 mm	L	10 mm	D	20 mm	SW	24 mm	E	28 mm
TL	36...45 mm												
L	10 mm												
D	20 mm												
SW	24 mm												
E	28 mm												

### 7.2. Special tool to turn the terminal box

#### Note:

- This special tool is not supplied with the valve (see “8.4. Ordering chart accessories” on page 16).
- This special tool can only be used with ATEX AC10 coils.

Description	Components of the set
Set SC02-AC10 	<ul style="list-style-type: none"> <li>• Special wrench</li> <li>• Service manual</li> </ul>

## 8. Ordering information

### 8.1. Bürkert eShop – Easy ordering and quick delivery



#### Bürkert eShop – Easy ordering and fast delivery

You want to find your desired Bürkert product or spare part quickly and order directly? Our online shop is available for you 24/7. Sign up and enjoy all the benefits.

[Order online now](#)

### 8.2. Bürkert product filter



#### Bürkert product filter – Get quickly to the right product

You want to select products comfortably based on your technical requirements? Use the Bürkert product filter and find suitable articles for your application quickly and easily.

[Try out our product filter](#)

### 8.3. Ordering chart

#### Standard version with brass body

**Note:**

Please note that the cable plug has to be ordered separately, see **“8.4. Ordering chart accessories” on page 16** or separate datasheet **Type 2518** ▶.

Circuit function	Port connection	Orifice	K <sub>v</sub> value water	Pressure range	Weight	Article no. per voltage/frequency [V/Hz]		
		[mm]	[m³/h]	[bar]		024/DC	024/50-60	230/50-60
<b>Seal material NBR, polyamide coil, medium temperature - 10 °C... +80 °C</b>								
<b>A, solenoid valve</b> 2/2 way Servo-controlled Normally closed 	G ¼	10	1.5	0.2...16	0.43	322499	322500	322501
	G ⅜	10	1.9	0.2...16	0.40	322502	322503	322504
	G ⅝	13	3.8	0.2...16	0.58	221841	221842	221843
	G ½	13	3.8	0.2...16	0.54	221844	221845	221846
	G ¾	13	3.8	0.2...16	0.59	221847	221848	221849
	G ¾	20	8.5	0.2...16	0.89	221850	221851	221852
	G 1	20	8.5	0.2...16	1.0	221853	221854	221855
	G 1	25	12	0.2...16	1.3	221856	221857	221858
	G 1¼	25	12	0.2...16	1.5	221859	221860	221861
	G 1¼	40	23	0.2...16	2.7	270131	268550	270132
	G 1½	40	30	0.2...16	3.0	221862	221863	221864
	G 2	40	30	0.2...16	3.2	221865	221866	221867
	G 2	50	40	0.2...16	4.5	253156	253157	253158
G 2½	50	40	0.2...16	5.2	253159	253160	253161	

DTS 1000152082 EN Version: N Status: RL (released | freigegeben | validé) printed: 06.04.2021

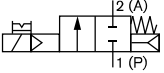
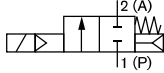
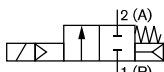
Circuit function	Port connection	Orifice	K <sub>v</sub> value water	Pressure range	Weight	Article no. per voltage/frequency [V/Hz]		
		[mm]	[m³/h]	[bar]	[kg]	024/DC	024/50-60	230/50-60
<b>Seal material NBR, polyamide coil, medium temperature -10 °C...+80 °C, with manual override</b>								
<b>A, solenoid valve</b> 2/2 way Servo-controlled, with manual mode Normally closed 	G ¼	10	1.5	0.2...16	0.43	322505 ☹	322506 ☹	322507 ☹
	G ⅜	10	1.9	0.2...16	0.40	322508 ☹	322509 ☹	322510 ☹
	G ½	13	3.8	0.2...16	0.54	221952 ☹	–	221953 ☹
	G ¾	13	3.8	0.2...16	0.59	221954 ☹	–	221955 ☹
	G ¾	20	8.5	0.2...16	0.89	221956 ☹	–	221957 ☹
	G 1	20	8.5	0.2...16	1.0	221958 ☹	–	221959 ☹
	G 1	25	12	0.2...16	1.3	221960 ☹	–	221961 ☹
	G 1¼	25	12	0.2...16	1.5	221962 ☹	–	221963 ☹
	G 1¼	40	23	0.2...16	2.7	270142 ☹	–	270143 ☹
	G 1½	40	30	0.2...16	3.0	221964 ☹	–	221965 ☹
G 2	40	30	0.2...16	3.2	221966 ☹	–	221967 ☹	
<b>Seal material FKM, epoxy coil, medium temperature 0 °C...+120 °C</b>								
<b>A, solenoid valve</b> 2/2 way Servo-controlled Normally closed 	G ¼	10	1.5	0.2...16	0.43	322511 ☹	322512 ☹	322513 ☹
	G ⅜	10	1.9	0.2...16	0.40	322514 ☹	322515 ☹	322516 ☹
	G ⅝	13	3.8	0.2...16	0.58	221868 ☹	221869 ☹	221870 ☹
	G ½	13	3.8	0.2...16	0.54	221871 ☹	221872 ☹	221873 ☹
	G ¾	13	3.8	0.2...16	0.59	221874 ☹	221875 ☹	221876 ☹
	G ¾	20	8.5	0.2...16	0.89	221877 ☹	221878 ☹	221879 ☹
	G 1	20	8.5	0.2...16	1.0	221880 ☹	221881 ☹	221882 ☹
	G 1	25	12	0.2...16	1.3	221883 ☹	221884 ☹	221885 ☹
	G 1¼	25	12	0.2...16	1.5	221886 ☹	221887 ☹	221888 ☹
	G 1¼	40	23	0.2...16	2.7	270133 ☹	270134 ☹	270135 ☹
	G 1½	40	30	0.2...16	3.0	221889 ☹	221890 ☹	221891 ☹
	G 2	40	30	0.2...16	3.2	221892 ☹	221893 ☹	221894 ☹
	G 2	50	40	0.2...16	4.5	253168 ☹	253169 ☹	253170 ☹
	G 2½	50	40	0.2...16	5.2	253171 ☹	253172 ☹	253173 ☹
<b>Seal material EPDM, polyamide coil, medium temperature -30 °C...+90 °C</b>								
<b>A, solenoid valve</b> 2/2 way Servo-controlled Normally closed 	G ¼	10	1.5	0.2...16	0.43	322517 ☹	322518 ☹	322519 ☹
	G ⅜	10	1.9	0.2...16	0.40	322520 ☹	322521 ☹	322522 ☹
	G ⅝	13	3.8	0.2...16	0.58	221895 ☹	221896 ☹	221897 ☹
	G ½	13	3.8	0.2...16	0.54	221898 ☹	221899 ☹	221900 ☹
	G ¾	13	3.8	0.2...16	0.59	221901 ☹	221902 ☹	221903 ☹
	G ¾	20	8.5	0.2...16	0.89	221904 ☹	221905 ☹	221906 ☹
	G 1	20	8.5	0.2...16	1.0	221907 ☹	221908 ☹	221909 ☹
	G 1	25	12	0.2...16	1.3	221910 ☹	221911 ☹	221912 ☹
	G 1¼	25	12	0.2...16	1.5	221913 ☹	221914 ☹	221915 ☹
	G 1¼	40	23	0.2...16	2.7	270136 ☹	270137 ☹	270138 ☹
	G 1½	40	30	0.2...16	3.0	221916 ☹	221917 ☹	221918 ☹
	G 2	40	30	0.2...16	3.2	221919 ☹	221920 ☹	221921 ☹
	G 2	50 <sup>1.)</sup>	40	0.2...16	4.5	253162 ☹	253163 ☹	253164 ☹
	G 2½	50 <sup>1.)</sup>	40	0.2...16	5.2	253165 ☹	253166 ☹	253167 ☹

1.) Drinking water approved acc. to KTW and W270

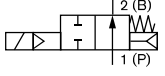
Circuit function	Port connection	Orifice	K <sub>v</sub> value water	Pressure range	Weight	Article no. per voltage/frequency [V/Hz]		
		[mm]	[m <sup>3</sup> /h]	[bar]		024/DC	024/50	230/50
<b>Seal material NBR, epoxy coil, medium temperature -10 °C...+80 °C</b>								
<b>B, solenoid valve</b> 2/2 way Servo-controlled Normally opened 	G ¼	10	1.5	0.2...16	0.43	322523 ₺	322524 ₺	322525 ₺
	G ⅜	10	1.9	0.2...16	0.40	322526 ₺	322527 ₺	322528 ₺
	G ⅝	13	3.8	0.2...16	0.58	221923 ₺	221924 ₺	221925 ₺
	G ½	13	3.8	0.2...16	0.54	221926 ₺	221928 ₺	221929 ₺
	G ¾	13	3.8	0.2...16	0.59	221930 ₺	221931 ₺	221933 ₺
	G ¾	20	8.5	0.2...16	0.89	221934 ₺	221935 ₺	221936 ₺
	G 1	20	8.5	0.2...16	1.0	221937 ₺	221938 ₺	221939 ₺
	G 1	25	12	0.2...16	1.3	221940 ₺	221941 ₺	221942 ₺
	G 1¼	25	12	0.2...16	1.5	221943 ₺	221944 ₺	221945 ₺
	G 1¼	40	23	0.2...16	2.7	270139 ₺	270140 ₺	270141 ₺
	G 1½	40	30	0.2...16	3.0	221946 ₺	221947 ₺	221948 ₺
	G 2	40	30	0.2...16	3.2	221949 ₺	221950 ₺	221951 ₺
	G 2	50	40	0.2...16	4.5	253174 ₺	253175 ₺	253176 ₺
	G 2½	50	40	0.2...16	5.2	253177 ₺	253178 ₺	253179 ₺

## Standard version with stainless steel body

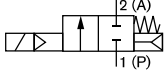
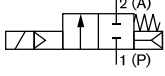
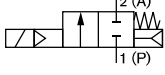
Circuit function	Port connection	Orifice	K <sub>v</sub> value water	Pressure range	Weight	Article no. per voltage/frequency [V/Hz]		
		[mm]	[m <sup>3</sup> /h]	[bar]		024/DC	024/50-60	230/50-60
<b>Seal material NBR, polyamide coil, medium temperature -10 °C...+80 °C</b>								
<b>A, solenoid valve</b> 2/2 way Servo-controlled Normally closed 	G ¼	10	1.5	0.2...16	0.43	322529 ₺	322530 ₺	322531 ₺
	G ⅜	10	1.9	0.2...16	0.40	322532 ₺	322533 ₺	322534 ₺
	G ½	13	3.8	0.2...16	0.54	221968 ₺	221969 ₺	221970 ₺
	G ¾	20	8.5	0.2...16	0.86	221971 ₺	221972 ₺	221973 ₺
	G 1	20	8.5	0.2...16	0.97	221974 ₺	221975 ₺	221976 ₺
	G 1	25	12	0.2...16	1.3	221977 ₺	221978 ₺	221979 ₺
	G 1¼	25	12	0.2...16	1.4	221980 ₺	221981 ₺	221982 ₺
	G 1½	40	30	0.2...16	2.8	221983 ₺	221984 ₺	221985 ₺
	G 2	40	30	0.2...16	3.0	221986 ₺	221987 ₺	221988 ₺
	<b>Seal material FKM, epoxy coil, medium temperature 0 °C...+120 °C</b>							
<b>A, solenoid valve</b> 2/2 way Servo-controlled Normally closed 	G ¼	10	1.5	0.2...16	0.43	322535 ₺	322536 ₺	322537 ₺
	G ⅜	10	1.9	0.2...16	0.40	322538 ₺	322539 ₺	322540 ₺
	G ½	13	3.8	0.2...16	0.54	221989 ₺	221990 ₺	221991 ₺
	G ¾	20	8.5	0.2...16	0.86	221992 ₺	221993 ₺	221994 ₺
	G 1	20	8.5	0.2...16	0.97	221995 ₺	221996 ₺	221997 ₺
	G 1	25	12	0.2...16	1.3	221998 ₺	221999 ₺	222000 ₺
	G 1¼	25	12	0.2...16	1.4	222001 ₺	222002 ₺	222003 ₺
	G 1½	40	30	0.2...16	2.8	222004 ₺	222005 ₺	222006 ₺
	G 2	40	30	0.2...16	3.0	222007 ₺	222008 ₺	222009 ₺
<b>Seal material FKM, epoxy coil, medium temperature 0 °C...+120 °C, with manual override</b>								
<b>A, solenoid valve</b> 2/2 way Servo-controlled Normally closed 	G ¼	10	1.5	0.2...16	0.43	323894 ₺	–	323968 ₺
	G ⅜	10	1.9	0.2...16	0.40	323971 ₺	–	323972 ₺
	G ½	13	3.8	0.2...16	0.54	323973 ₺	–	323975 ₺
	G ¾	20	8.5	0.2...16	0.86	323977 ₺	–	323978 ₺
	G 1	25	12	0.2...16	1.3	323979 ₺	–	323980 ₺
	G 1¼	25	1.4	0.2...16	1.4	323982 ₺	–	323984 ₺
	G 1½	40	30	0.2...16	2.8	323986 ₺	–	323987 ₺
	G 2	40	30	0.2...16	3.0	323988 ₺	–	323989 ₺

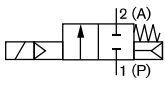
Circuit function	Port connection	Orifice	K <sub>v</sub> value water	Pressure range	Weight	Article no. per voltage/frequency [V/Hz]		
		[mm]	[m <sup>3</sup> /h]	[bar]		024/DC	024/50-60	230/50-60
<b>Seal material EPDM, polyamide coil, medium temperature -30 °C... +90 °C</b>								
<b>A, solenoid valve</b> 2/2 way Servo-controlled Normally closed 	G ¼	10	1.5	0.2...16	0.43	322541 ☞	322542 ☞	322543 ☞
	G ⅜	10	1.9	0.2...16	0.40	322544 ☞	322545 ☞	322546 ☞
	G ½	13	3.8	0.2...16	0.54	222010 ☞	222011 ☞	222012 ☞
	G ¾	20	8.5	0.2...16	0.86	222013 ☞	222014 ☞	222015 ☞
	G 1	20	8.5	0.2...16	0.97	222016 ☞	222017 ☞	222018 ☞
	G 1	25	12	0.2...16	1.3	222019 ☞	222020 ☞	222021 ☞
	G 1¼	25	12	0.2...16	1.4	222022 ☞	222023 ☞	222024 ☞
	G 1½	40	30	0.2...16	2.8	222025 ☞	222026 ☞	222027 ☞
	G 2	40	30	0.2...16	3.0	222028 ☞	222029 ☞	222031 ☞

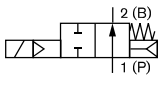
Circuit function	Port connection	Orifice	K <sub>v</sub> value water	Pressure range	Weight	Article no. per voltage/frequency [V/Hz]		
		[mm]	[m <sup>3</sup> /h]	[bar]		024/DC	024/50	230/50
<b>Seal material FKM, epoxy coil, medium temperature 0 °C... +120 °C</b>								
<b>B, solenoid valve</b> 2/2 way Servo-controlled Normally opened 	G ¼	10	1.5	0.2...16	0.43	322547 ☞	322548 ☞	322549 ☞
	G ⅜	10	1.9	0.2...16	0.40	322550 ☞	322551 ☞	322552 ☞
	G ½	13	3.8	0.2...16	0.54	228387 ☞	228388 ☞	228389 ☞
	G ¾	20	8.5	0.2...16	0.86	228390 ☞	228391 ☞	228392 ☞
	G 1	25	12	0.2...16	1.3	228393 ☞	228394 ☞	228395 ☞
	G 1¼	25	12	0.2...16	1.4	228396 ☞	228397 ☞	228398 ☞
	G 1½	40	30	0.2...16	2.8	228399 ☞	228400 ☞	228401 ☞
	G 2	40	30	0.2...16	3.0	228402 ☞	228403 ☞	228404 ☞

#### Explosion proofed version ATEX and IECEx, electrical connection with 3 m cable

##### Note:

- The maximum fluid temperature must not in any case exceed the permissible temperature class (T4 135 °C, T5 100 °C, T6 85 °C), minus 5 K.
- Detailed information on the approvals can be found in the chapter **"3. Approvals"** on page 4.

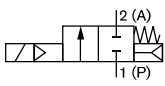
Circuit function	Port connection	Orifice	K <sub>v</sub> value water	Pressure range	Weight	Article no. per voltage/frequency [V/Hz]	
		[mm]	[m <sup>3</sup> /h]	[bar]		024/UC	230/UC
<b>Seal material NBR, brass body, medium temperature -10 °C... +80 °C</b>							
<b>A, solenoid valve</b> 2/2 way Servo-controlled Normally closed 	G ¼	10	1.5	0.2...16	0.62	349656 ☞	349658 ☞
	G ⅜	10	1.9	0.2...16	0.59	349660 ☞	349662 ☞
	G ½	13	3.8	0.2...16	0.84	349690 ☞	349696 ☞
	G ¾	20	8.5	0.2...16	1.2	349717 ☞	349719 ☞
	G 1	25	12	0.2...16	1.7	349731 ☞	349734 ☞
	G 1¼	25	12	0.2...16	1.8	349737 ☞	349739 ☞
	G 1¼	40	23	0.2...16	3.0	349751 ☞	349754 ☞
	G 1½	40	30	0.2...16	3.3	349756 ☞	349758 ☞
	G 2	40	30	0.2...16	3.5	349760 ☞	349762 ☞
	G 2	50	40	0.2...16	4.8	349773 ☞	349775 ☞
G 2½	50	40	0.2...16	5.5	349777 ☞	349778 ☞	

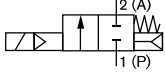
Circuit function	Port connection	Orifice	K <sub>v</sub> value water	Pressure range	Weight	Article no. per voltage/frequency [V/Hz]	
		[mm]	[m³/h]	[bar]	[kg]	024/UC	230/UC
<b>Seal material FKM, stainless steel body, medium temperature 0 °C... +90 °C</b>							
<b>A, solenoid valve</b> 2/2 way Servo-controlled Normally closed 	G ¼	10	1.5	0.2...16	0.62	349665 ☒	349666 ☒
	G ⅜	10	1.9	0.2...16	0.59	349669 ☒	349670 ☒
	G ½	13	3.8	0.2...16	0.84	349707 ☒	349708 ☒
	G ¾	20	8.5	0.2...16	1.2	349724 ☒	349727 ☒
	G 1	25	12	0.2...16	1.6	349742 ☒	349744 ☒
	G 1¼	25	12	0.2...16	1.7	349747 ☒	349750 ☒
	G 1½	40	30	0.2...16	3.1	349765 ☒	349767 ☒
	G 2	40	30	0.2...16	3.3	349770 ☒	349771 ☒

#### Explosion proofed version ATEX and IECEx, electrical connection with terminal box

##### Note:

- The maximum fluid temperature must not in any case exceed the permissible temperature class (T4 135 °C, T5 100 °C, T6 85 °C), minus 5 K.
- Detailed information on the approvals can be found in the chapter **"3. Approvals"** on page 4.

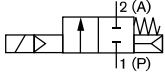
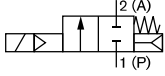
Circuit function	Port connection	Orifice	K <sub>v</sub> value water	Pressure range	Weight	Article no. per voltage/frequency [V/Hz]	
		[mm]	[m³/h]	[bar]	[kg]	024/UC	230/UC
<b>Seal material NBR, brass body, medium temperature -10 °C... +80 °C</b>							
<b>A, solenoid valve</b> 2/2 way Servo-controlled Normally closed <sup>1.)</sup> 	G ¼	10	1.5	0.2...16	0.62	349657 ☒	349659 ☒
	G ⅜	10	1.9	0.2...16	0.59	349661 ☒	349663 ☒
	G ½	13	3.8	0.2...16	0.84	349691 ☒	349697 ☒
	G ¾	20	8.5	0.2...16	1.2	349718 ☒	349720 ☒
	G 1	25	12	0.2...16	1.7	349733 ☒	349735 ☒
	G 1¼	25	12	0.2...16	1.8	349738 ☒	349740 ☒
	G 1¼	40	23	0.2...16	3.0	349753 ☒	349755 ☒
	G 1½	40	30	0.2...16	3.3	349757 ☒	349759 ☒
	G 2	40	30	0.2...16	3.5	349761 ☒	349763 ☒
	G 2	50	40	0.2...16	4.8	349774 ☒	349776 ☒
<b>Seal material FKM, stainless steel body, medium temperature 0 °C... +90 °C</b>							
<b>A, solenoid valve</b> 2/2 way Servo-controlled Normally closed <sup>1.)</sup> 	G ¼	10	1.5	0.2...16	0.62	349664 ☒	349667 ☒
	G ⅜	10	1.9	0.2...16	0.59	349668 ☒	349671 ☒
	G ½	13	3.8	0.2...16	0.84	349705 ☒	349709 ☒
	G ¾	20	8.5	0.2...16	1.2	349725 ☒	349728 ☒
	G 1	25	12	0.2...16	1.6	349743 ☒	349745 ☒
	G 1¼	25	12	0.2...16	1.7	349748 ☒	349749 ☒
	G 1½	40	30	0.2...16	3.1	349766 ☒	349768 ☒
	G 2	40	30	0.2...16	3.3	349769 ☒	349772 ☒

1.) Only with Epoxy coil available

**Compressor relief valve with brass body**

**Note:**

- Please note that the cable plug has to be ordered separately, see **“8.4. Ordering chart accessories” on page 16** or separate datasheet **Type 2518** ▶.
- In deenergized state the valve is open. The medium also flows off via the vent on the coil.

Circuit function	Port connection	Orifice	K <sub>v</sub> value water	Pressure range	Weight	Article no. per voltage/frequency [V/Hz]				
		[mm]	[m³/h]	[bar]	[kg]	024/DC	024/50-60	110/50-60	230/50-60	
<b>Seal material FKM, polyamide coil, medium temperature 0 °C... +90 °C, DN10_CFO5</b>										
<b>B, solenoid valve</b> 2/2 way Servo-controlled Normally opened	G 3/8	10	1.9	0.2...16	0.43	330985	330986	330987	330988	
	G 1/2	10	1.9	0.2...16	0.40	330989	331007	331008	331009	
<b>Seal material FKM, polyamide coil, medium temperature 0 °C... +90 °C, DN13</b>										
<b>B, solenoid valve</b> 2/2 way Servo-controlled Normally opened	G 3/8	13	3.6	0.5...16	0.58	310663	310662	310661	310659	
	G 1/2	13	3.6	0.5...16	0.54	310667	310666	310665	310664	

Further versions on request	
<b>Material</b> Brass dezincification resistant	<b>Temperature</b> <ul style="list-style-type: none"> <li>• EPDM version up to +100 °C with epoxy coil</li> <li>• FKM version up to +120 °C with epoxy coil</li> </ul>
<b>Process connection</b> NPT, Rc	<b>Approval</b> <ul style="list-style-type: none"> <li>• European drinking water approval acc. to KTW W270 (Var. code PF23)</li> <li>• VDE sign permission acc. to DIN EN 60730 (Var. code PW01)</li> <li>• UL-Zulassung UL429 (Var. Code PE94/PE95)</li> <li>• Schifffahrtzulassung DNV-GL (Var. Code PD07)</li> </ul>
<b>Voltage</b> Further voltages	

**8.4. Ordering chart accessories**

**Cable plug Type 2513, form A acc. to DIN EN 175301-803**

**Note:**

- The Cable plug Type 2513 meets the requirements of ATEX category 3 GD.
- For more information on the cable plug, see data sheet **Type 2513** ▶.





Cable plug	circuit diagram	Cable length [mm]	Article no.
		12000	260893
		5000	260892
		3000	260891
		300	260890

DTS 1000152082 EN Version: N Status: RL (released | freigegeben | validé) printed: 06.04.2021

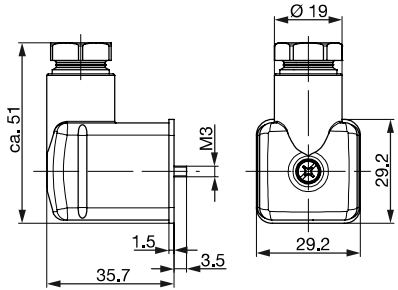

## Cable plug Type 2518, Form A according to DIN EN 175301-803



**Note:**Further versions see data sheet [Type 2518](#) ▶.

Cable plug	Dimensions	Version	Voltage	Article no.
		Without circuitry (AC/DC)	0...250 V AC/DC	314802 
		With LED (AC/DC)	12...24 V AC/DC	314812 
		With LED and varistor (AC/DC)	12...24 V AC/DC	314820 
		With rectifier, LED and varistor	12...24 V AC/DC	314816 

## Cable glands for ATEX/IECEx terminal box

**Note:**



- A cable gland in polyamide version is included in the delivery. A nickel-plated brass version can be ordered at surcharge.
- For more information on Ex cable glands, see [“6.1. Cable glands for ATEX/IECEx terminal box” on page 12.](#)
- For more information on Special wrench see [“7.2. Special tool to turn the terminal box” on page 10.](#)

Description	Article no.
Ex cable gland, brass, nickelplated, 6...13 mm <sup>1.)</sup>	773278 
Ex cable gland, polyamide, 7...13 mm <sup>1.)</sup>	773277 
Set SC02-AC10: Special wrench <sup>2.)</sup> incl. service manual	293488 

1.) Cable diameter

2.) Not included in the scope of delivery of the valve

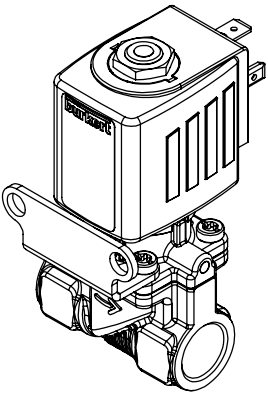
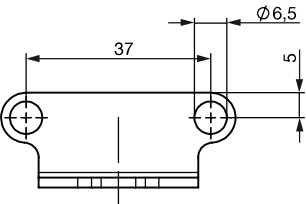
## Mounting set for DN10

Cable plug	Dimensions	Description	Article no.
		Bestehend aus Befestigungswinkel und Schrauben	365730 

# Bürkert – Close to You

For up-to-date addresses  
please visit us at  
[www.burkert.com](http://www.burkert.com)

DTS 1000152082 EN Version: N Status: RL (released | freigegeben | validé) printed: 06.04.2021

