

2-Color Display High Precision Digital Pressure Switch



IP65
compliant

RoHS
compliant

Applicable fluid

Air, Non-corrosive gas, Non-flammable gas

Can copy to up to 10 switches simultaneously.

The settings of the master pressure switch (source of copy) can be copied to the slave pressure switches.

- Reduction in setting work
- Prevention of mistakes in setting

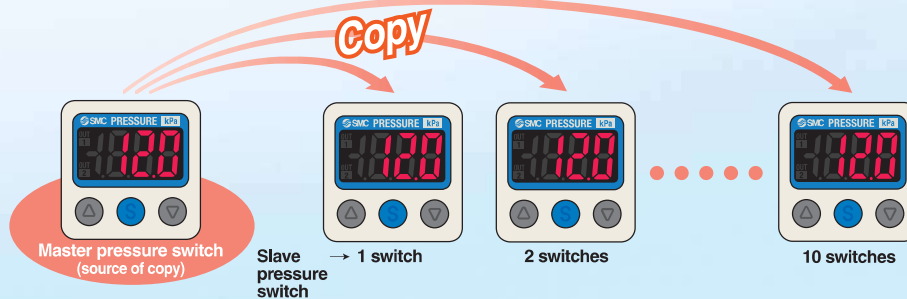

Easy handling!



Raised rubber switch buttons for easy and comfortable operation

3-step setting

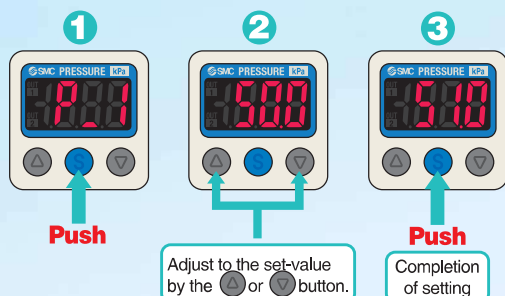

2-color display

See abnormal values at a glance.



Piping Variations

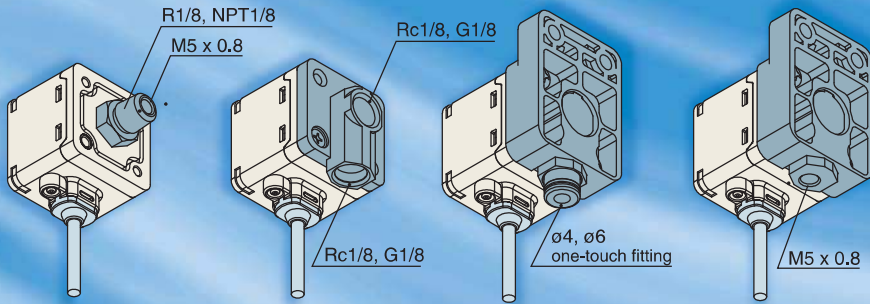

Space-saving

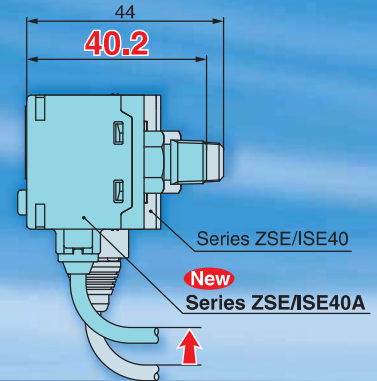

Mounting Variations

Bracket A

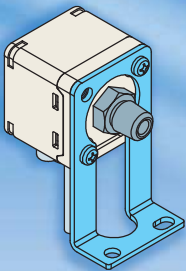

Bracket B

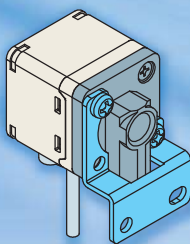

Bracket D

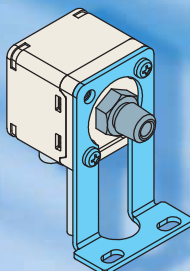

Interchangeable with the ZSE40/ISE40 series for mounting

Direct mounting
(Wall mounting)

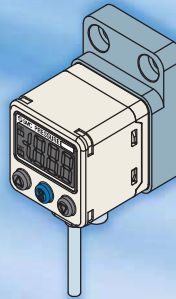

Panel mounting

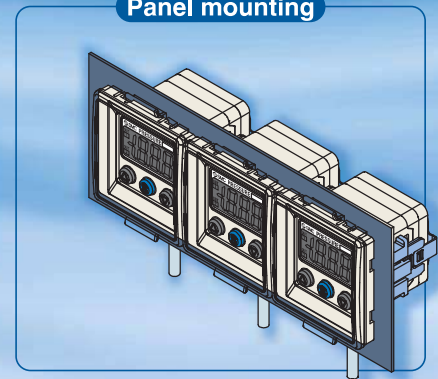

Series

Series	ZSE40A (vacuum pressure)	ZSE40AF (compound pressure)	ISE40A (positive pressure)
Rated pressure range	0.00 to -14.69 psi -14.69 psi	-14.50 to 14.50 psi 14.5 psi -14.5 psi	-14.5 to 145.0 psi 145 psi -14.5 psi
Set pressure range	1.45 to -15.23 psi	-15.22 to 15.22 psi	-15.2 to 152.3 psi
Withstand pressure	72.5 psi	72.5 psi	218 psi
Min. unit setting	0.01 psi	0.02 psi	0.1 psi
Output	<ul style="list-style-type: none"> NPN or PNP open collector 2 outputs + Copy function NPN or PNP open collector 2 outputs + Analog output (voltage or current)/Auto-shift input 		
Piping	R1/8, NPT1/8 (With M5 female thread), Rc1/8, G1/8, M5 female thread ø4, ø6 one-touch fitting		

Secret code setting function

A function to prevent operation by anyone other than the designated operator while the keys are locked.



An optional 3-digit value is entered.

* The set-value can be checked while the keys are locked.

Power-saving function

The display can be turned off to save the power consumption. (Power consumption reduced by max. 20%)



The value disappears and decimal points start flashing.

Resolution conversion function

The flickering on the display can be eliminated.



1/1000 → 1/100
(Only the displayed value is changed, and there is no effect on the accuracy.)

MPa/kPa switching function

The indication unit for vacuum, compound pressure and positive pressure can be integrated into either MPa or kPa.



kPa Stick the label (enclosed with the product) of a desired unit seal.

2-Color Display High Precision Digital Pressure Switch



Series ZSE40A(F)/ISE40A

How to Order

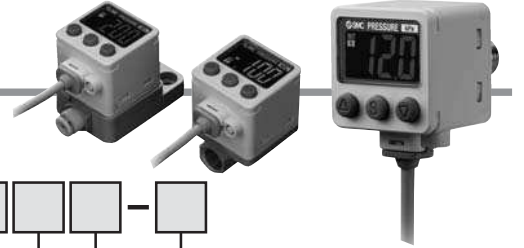

Rated pressure range

ISE40A	-14.5 to 145.0 psi
--------	--------------------

For positive pressure

ISE40A - **01** - **X** - **P** [] [] - []

For vacuum/compound pressure

ZSE40A - **01** - **Y** - **P** [] [] - []

Rated pressure range

ZSE40A	0.00 to -14.69 psi
ZSE40AF	-14.50 to 14.50 psi

Piping specifications

		R1/8, NPT1/8
01	R1/8 (With M5 female thread)	
N01	NPT1/8 (With M5 female thread)	
W1	Rc1/8	
WF1*	G1/8	
M5*	M5 x 0.8 (Female thread)	
C4*	ø4 one-touch fitting	
C6*	ø6 one-touch fitting	

* Made to Order

Combination of piping specifications with option 1 and part numbers of options

Option 1	Piping									
	Description	Symbol	Part no.	01	N01	W1	WF1	M5	C4	C6
Bracket A	A	ZS-24-A	○	○	○	○	○	×	×	×
Bracket B	B	ZS-24-B	×	×	○	○	○	×	×	×
Bracket D	D	ZS-24-D	○	○	○	○	○	×	×	×
Panel mount adapter	E	ZS-35-C	○	○	×	×	×	×	×	×
	F	ZS-35-D	×	×	○	○	○	○	○	○
Panel mount adapter + Front protective cover	F	ZS-35-F	○	○	×	×	×	×	×	×
	G	ZS-35-G	×	×	○	○	○	○	○	○

Output specifications

R	NPN open collector 2 outputs + Analog voltage/Auto-shift switching
T	PNP open collector 2 outputs + Analog voltage/Auto-shift switching
S	NPN open collector 2 outputs + Analog current/Auto-shift switching
V	PNP open collector 2 outputs + Analog current/Auto-shift switching
X	NPN open collector 2 outputs + Copy function
Y	PNP open collector 2 outputs + Copy function

When optional parts are required separately, Options/Part No. use the following part numbers to place an order.

Part no.	Option
ZS-24-A	Bracket A With 2 mounting screws of each M3 x 5L, M4 x 5L
ZS-24-B	Bracket B With 2 mounting screws M4 x 5L
ZS-24-D	Bracket D With 2 mounting screws of each M3 x 5L, M4 x 5L
ZS-35-C	Panel mount adapter (Piping: For 01/N01)
ZS-35-D	Panel mount adapter (Piping: For W1/WF1/M5/C4/C6)
ZS-35-F	Panel mount adapter + Front protective cover (Piping: For 01/N01)
ZS-35-G	Panel mount adapter + Front protective cover (Piping: For W1/WF1/M5/C4/C6)

Unit specifications

Nil	With unit switching function <small>Note 1)</small>
M	Fixed SI unit <small>Note 2)</small>
P	With unit switching function <small>Note 1)</small> (Initial value psi)

Note 1) Under the New Measurement Law, sales of switches with the unit switching function are not allowed for use in Japan.

Note 2) Fixed unit:
For vacuum/compound pressure: kPa
For positive pressure: MPa

Made to Order

Option 2

Symbol	Calibration certificate
Nil	—
K	○

Symbol	Specifications/Description
X501	Lead wire length 3 m
X531	M12 4-pin pre-wired connector (Lead wire length 100 mm)

Refer to page 17 for details.

Option 1*

Nil	None	
A	Bracket A	
B	Bracket B	
D	Bracket D	
E	Panel mount adapter 01/N01	
F	Panel mount adapter + Front protective cover 01/N01	

* Some options are unavailable depending on the piping specifications. Refer to "Combination of piping specifications with option 1 and part numbers of options".

Series ZSE40A(F)/ISE40A

Specifications

Model		ZSE40A (vacuum pressure)	ZSE40AF (compound pressure)	ISE40A (positive pressure)	
Rated pressure range		0.00 to -14.69 psi	-14.50 to 14.50 psi	-14.5 to 145.0 psi	
Display/Set pressure range		1.45 to -15.23 psi	-15.22 to 15.22 psi	-15.2 to 152.3 psi	
Withstand pressure		72.5 psi	72.5 psi	218 psi	
Display/Minimum unit setting		0.01 psi	0.02 psi	0.1 psi	
Applicable fluid		Air, Non-corrosive gas, Non-flammable gas			
Power supply voltage		12 to 24 VDC $\pm 10\%$, Ripple (p-p) 10% or less (with power supply polarity protection)			
Current consumption		45 mA or less			
Switch output		NPN or PNP open collector 2 outputs (Selectable)			
Maximum load current		80 mA			
Maximum applied voltage		28 V (at NPN output)			
Residual voltage		1 V or less			
Response time		2.5 ms (with anti-chattering function: 20, 100, 500, 1000, 2000 ms)			
Short circuit protection		Yes			
Repeat accuracy		$\pm 0.2\%$ F.S. ± 1 digit			
Hysteresis	Hysteresis mode	Variable (0 or above) ^{Note 1)}			
	Window comparator mode				
Analog output	^{Note 2)} Voltage output	Output voltage (Rated pressure range)	1 to 5 V $\pm 2.5\%$ F.S.	0.6 to 5 V $\pm 2.5\%$ F.S.	
		Linearity	$\pm 1\%$ F.S. or less		
		Output impedance	Approx. 1 k Ω		
	^{Note 3)} Current output	Output current (Rated pressure range)	4 to 20 mA $\pm 2.5\%$ F.S.	2.4 to 20 mA $\pm 2.5\%$ F.S.	
		Linearity	$\pm 1\%$ F.S. or less		
		Load impedance	Maximum load impedance: 300 Ω (Power supply voltage 12 V) 600 Ω (Power supply voltage 24 V) Minimum load impedance: 50 Ω		
Auto-shift input		Non-voltage input (Reed or Solid state), Low level: 0.4 V or less, 5 ms or longer input			
Display		3 1/2-digit, 7-segment, 2-color LCD (Red/Green)			
Display accuracy		$\pm 2\%$ F.S. ± 1 digit (Ambient temperature of 77 $\pm 5^\circ$ F)			
Indicator light		Lights up when output is turned ON. OUT1, OUT2: Orange			
Environment resistance	Enclosure		IP65		
	Operating temperature range		Operating: 23 to 122 $^\circ$ F, Stored: 14 to 140 $^\circ$ F (No freezing or condensation)		
	Operating humidity range		Operating/Stored: 35 to 85% RH (No condensation)		
	Withstand voltage		1000 VAC for 1 minute between live parts and case		
	Insulation resistance		50 M Ω or more between live parts and case (at 500 VDC Mega)		
	Vibration resistance		10 to 150 Hz at whichever is smaller of 1.5 mm amplitude or 20 m/s ² acceleration, in X, Y, Z directions, for 2 hours each (De-energized)		
Impact resistance		100 m/s ² in X, Y, Z directions, 3 times each (De-energized)			
Temperature characteristics		$\pm 2\%$ F.S. (Based on 77 $^\circ$ F)			
Lead wire		Oilproof heavy-duty vinyl cable $\phi 3.5$, 2 m Conductor area: 0.15 mm ² (AWG26) Insulator O.D.: 0.95 mm			
Standards		CE marking, UL (CSA), RoHS compliance			

Note 1) If the applied voltage fluctuates around the set-value, the hysteresis must be set to a value more than the fluctuating width, otherwise chattering will occur.

Note 2) When the analog voltage output is selected, the analog current output cannot be selected.

Note 3) When the analog current output is selected, the analog voltage output cannot be selected.

Piping Specifications

Part no.		01	N01	W1	WF1	M5	C4	C6
Port size		R1/8 (With M5 female thread)	NPT1/8 (With M5 female thread)	Rc1/8	G1/8	M5 x 0.8 female thread	$\phi 4$ one-touch fitting	$\phi 6$ one-touch fitting
Material of parts in contact with fluid	Sensor pressure receiving area	Silicon						
	Piping port	C3602 (Electroless nickel plated) O-ring: HNBR		ZDC2 O-ring: HNBR		ZDC2, POM, Stainless steel 304, C3604 (Electroless nickel plated) O-ring: HNBR		
Weight		78 g	79 g	97 g	104 g	101 g		

Analog Output

Voltage output

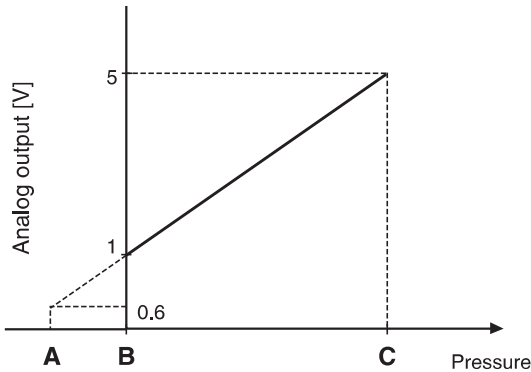

Current output

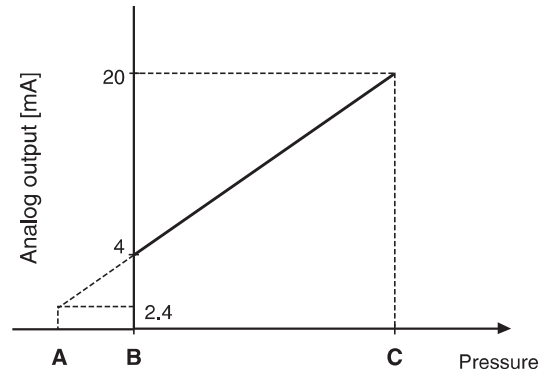

Range	Rated pressure range	A	B	C
For vacuum pressure	0.00 to -14.69 psi	1.47 psi	0	-14.69 psi
For compound pressure	-14.50 to 14.50 psi	—	-14.50 psi	14.50 psi
For positive pressure	-14.5 to 145.0 psi	-14.5 psi	0	145.0 psi

Descriptions

Output (OUT1) display (Orange)

Lights up when OUT1 is turned ON.

Output (OUT2) display (Orange)

Lights up when OUT2 is turned ON.

△ button

Use this button to select the mode or increase the ON/OFF set-value. It is also used for switching to the peak display mode.

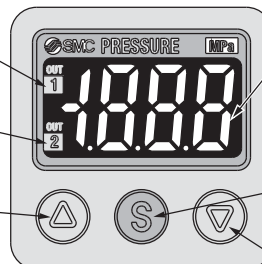

LCD

Displays the current pressure, set mode, selected display unit, and error code. Always use red or green display; or switch between green and red according to the output. Four different display settings are available.

SET button

Use this button to change the mode or confirm the set-value.

▽ button

Use this button to select the mode or decrease the ON/OFF set-value. It is also used for switching to the bottom display mode.

Series ZSE40A(F)/ISE40A

Internal Circuits and Wiring Examples

-R NPN (2 outputs) + Analog voltage output

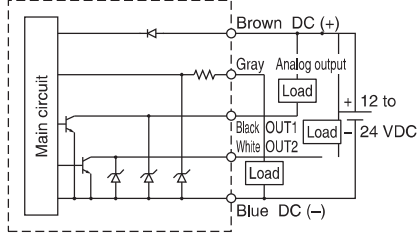

Max. 28 V, 80 mA
Residual voltage 1 V or less

-S NPN (2 outputs) + Analog current output

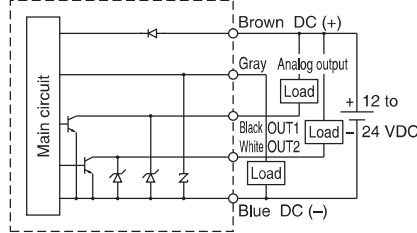

Max. 28 V, 80 mA
Residual voltage 1 V or less

-R/-S NPN (2 outputs) + Auto-shift input

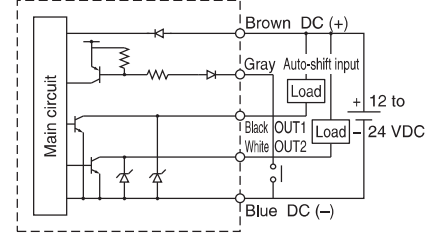

Max. 28 V, 80 mA
Residual voltage 1 V or less

-T PNP (2 outputs) + Analog voltage output

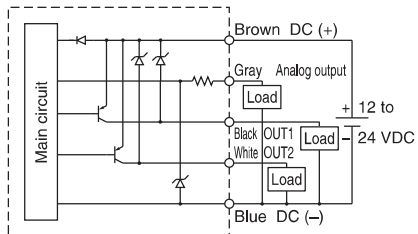

Max. 80 mA
Residual voltage 1 V or less

-V PNP (2 outputs) + Analog current output

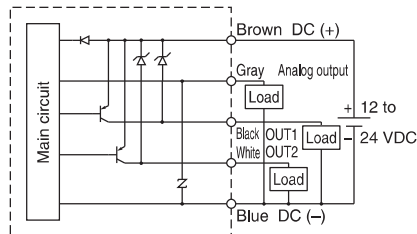

Max. 80 mA
Residual voltage 1 V or less

-T/-V PNP (2 outputs) + Auto-shift input

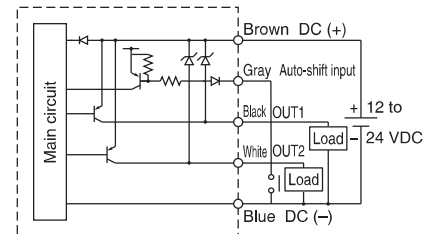

Max. 80 mA
Residual voltage 1 V or less

-X NPN (2 outputs) + Copy function

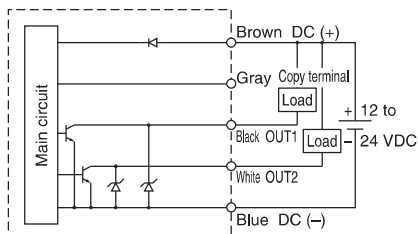

Max. 28 V, 80 mA
Residual voltage 1 V or less

-Y PNP (2 outputs) + Copy function

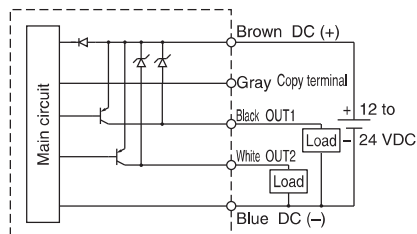

Max. 80 mA
Residual voltage 1 V or less

Dimensions

ZSE40A(F)/ISE40A-01

-N01

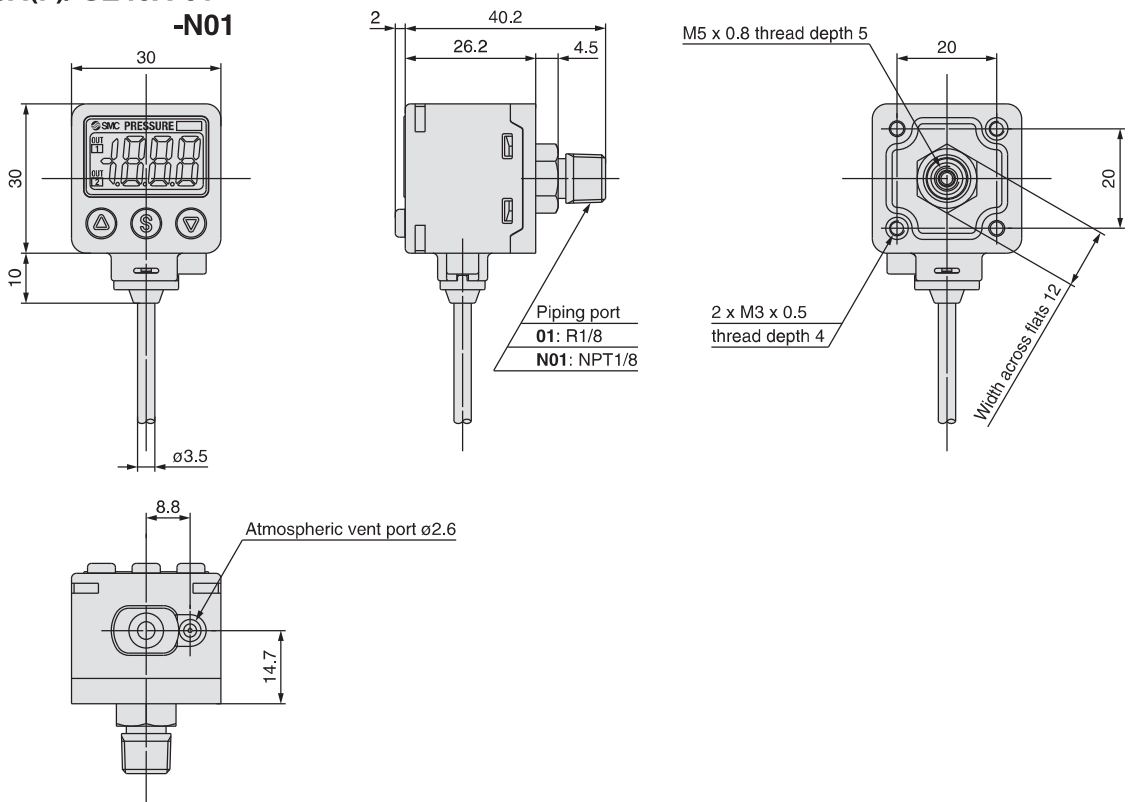

ZSE40A(F)/ISE40A-W1

-WF1

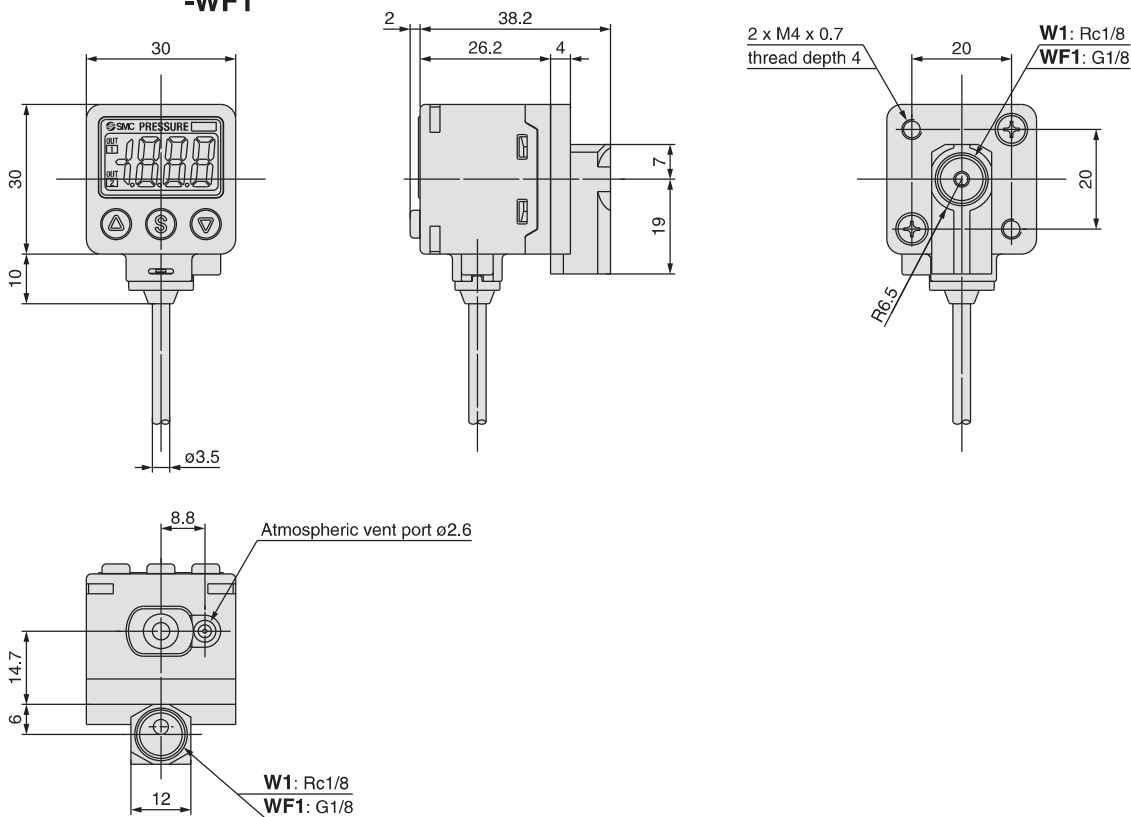

Series ZSE40A(F)/ISE40A

Dimensions

ZSE40A(F)/ISE40A-C4 -C6

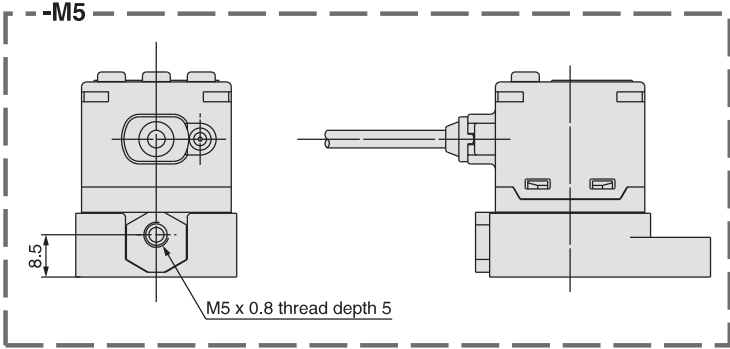
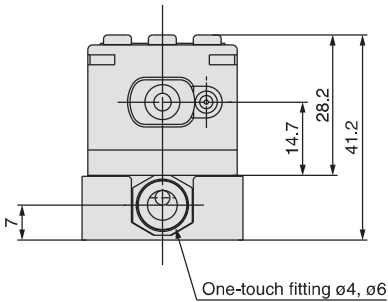
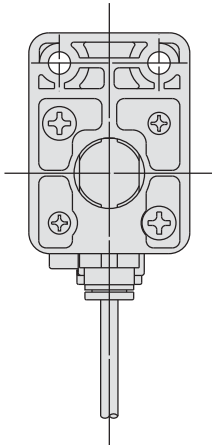
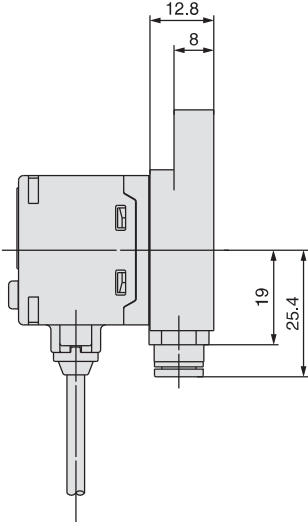
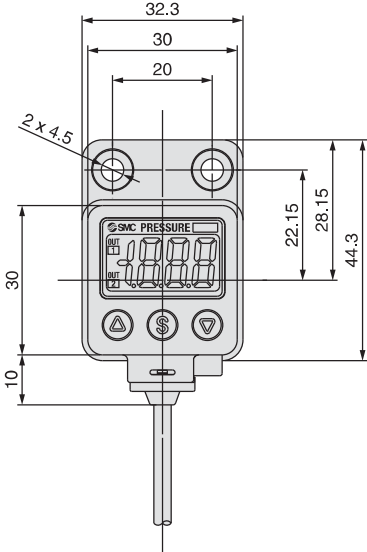

Dimensions

ZSE40A(F)/ISE40A-01-□-□A□

-N01-□-□A□

With bracket

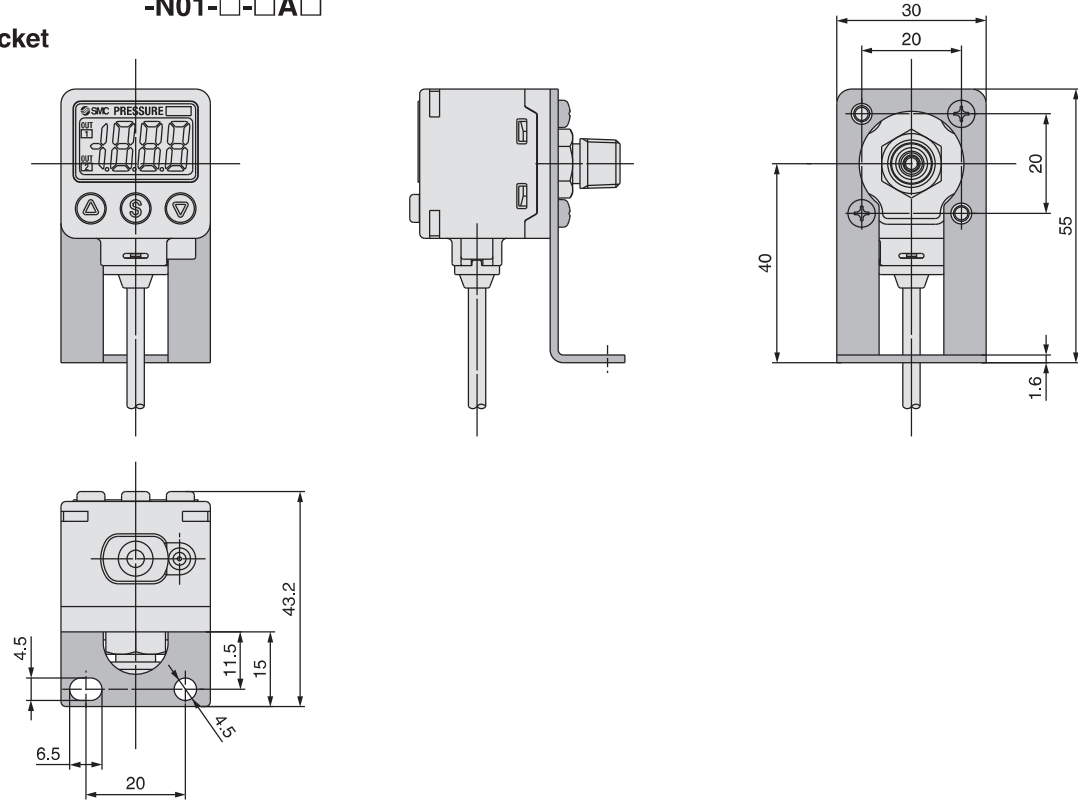

ZSE40A(F)/ISE40A-01-□-□D□

-N01-□-□D□

With bracket

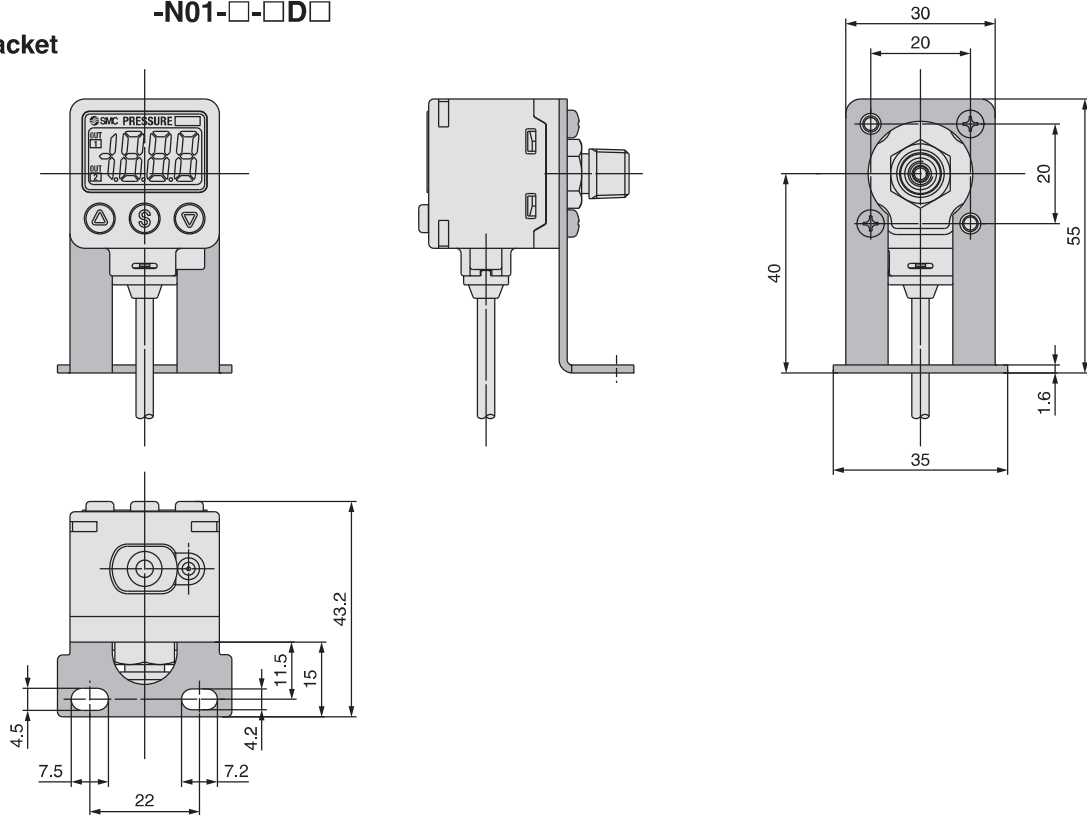

Series ZSE40A(F)/ISE40A

Dimensions

ZSE40A(F)/ISE40A-W1-□-□A□
-WF1-□-□A□

With bracket

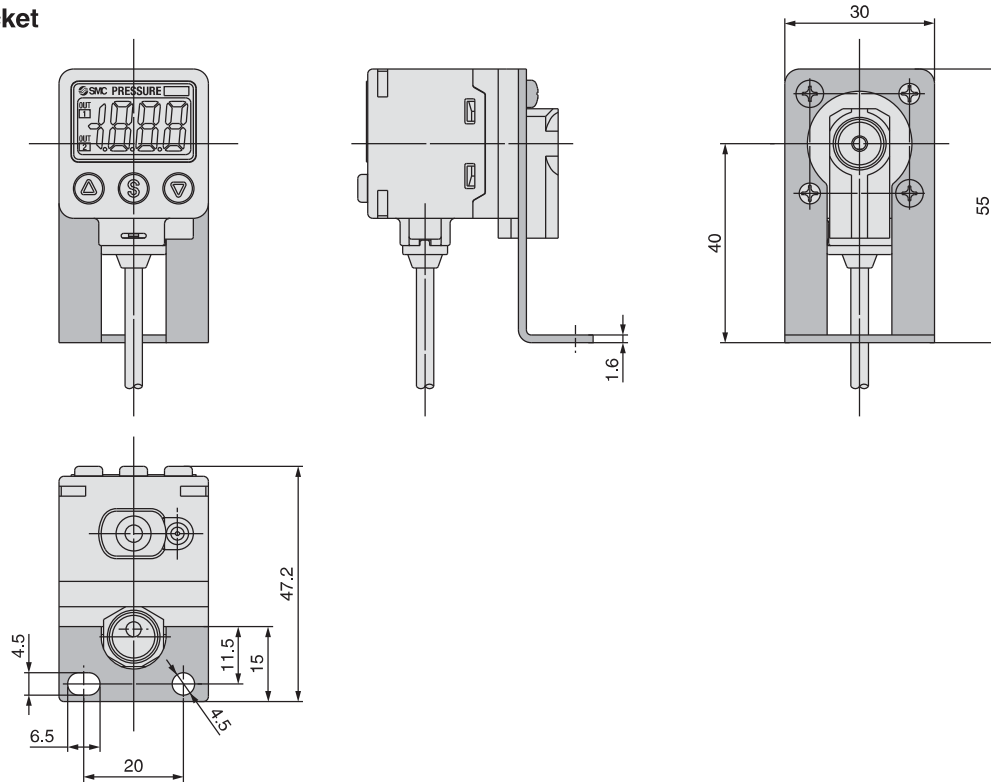

ZSE40A(F)/ISE40A-W1-□-□B□
-WF1-□-□B□

With bracket

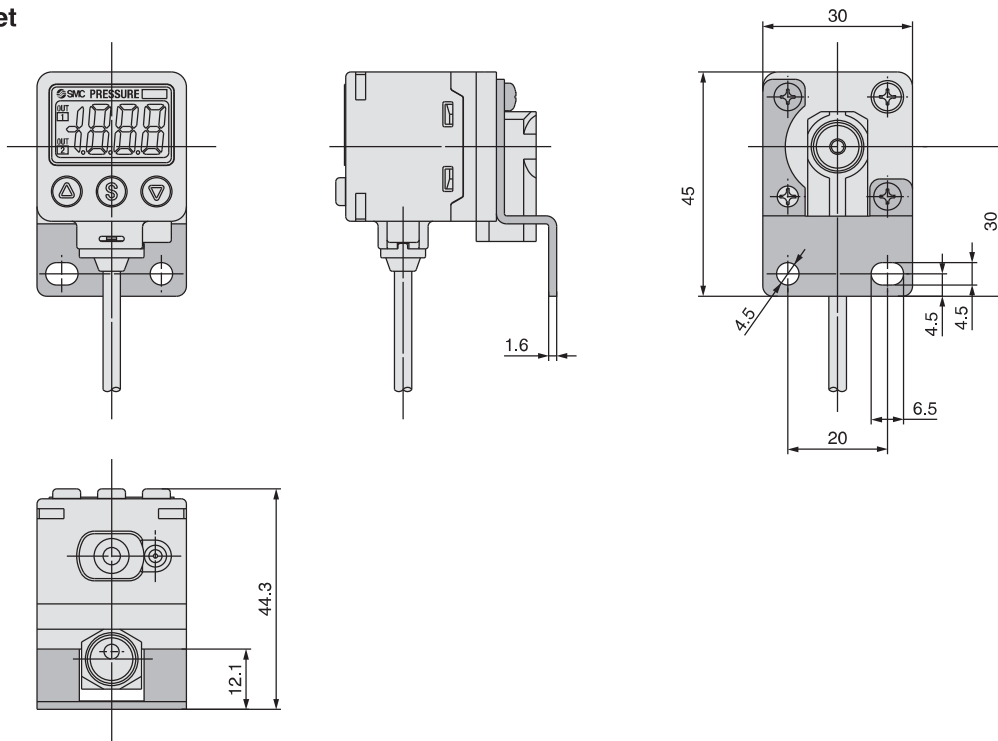

Dimensions

ZSE40A(F)/ISE40A-W1-□-□D□

-WF1-□-□D□

With bracket

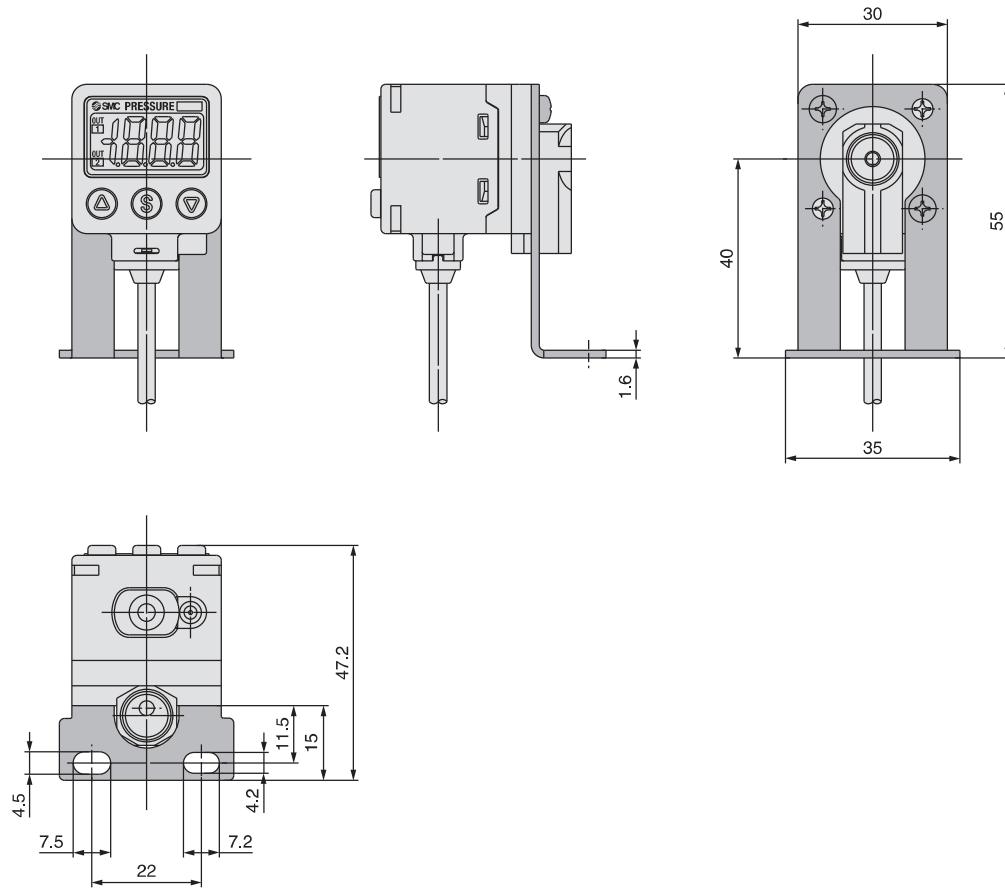

Series ZSE40A(F)/ISE40A

Dimensions

ZSE40A(F)/ISE40A-01-□-□E□

-N01-□-□E□

Panel mounting

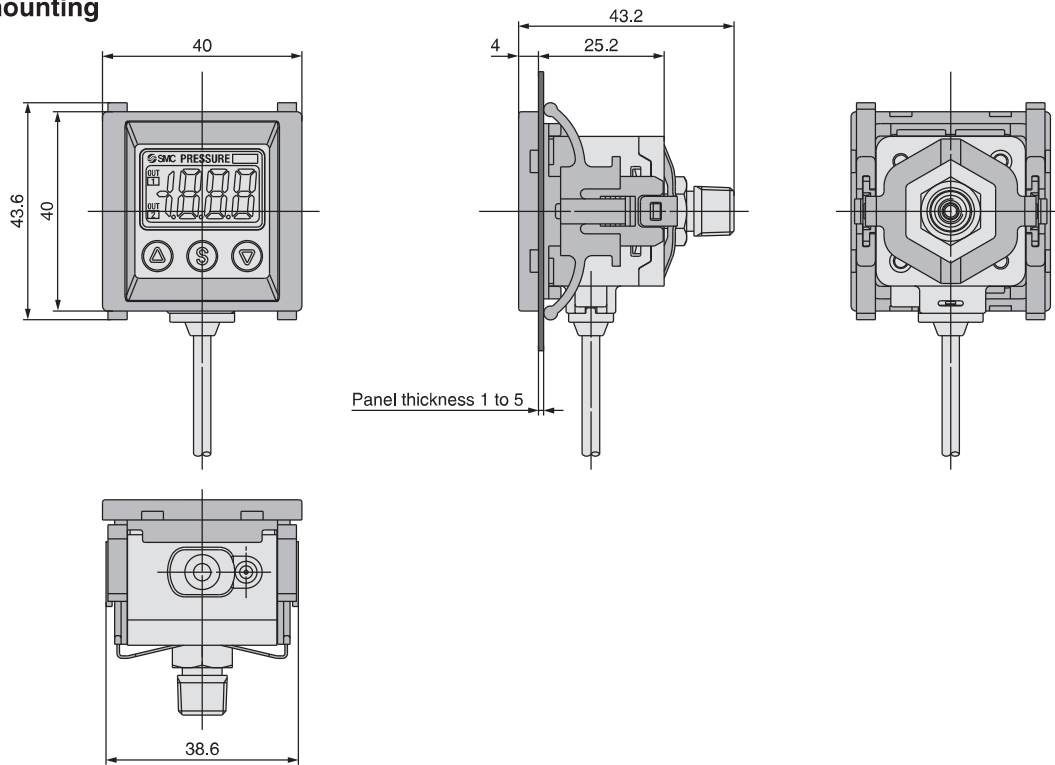

ZSE40A(F)/ISE40A-01-□-□F□

-N01-□-□F□

Panel mounting + Front protective cover

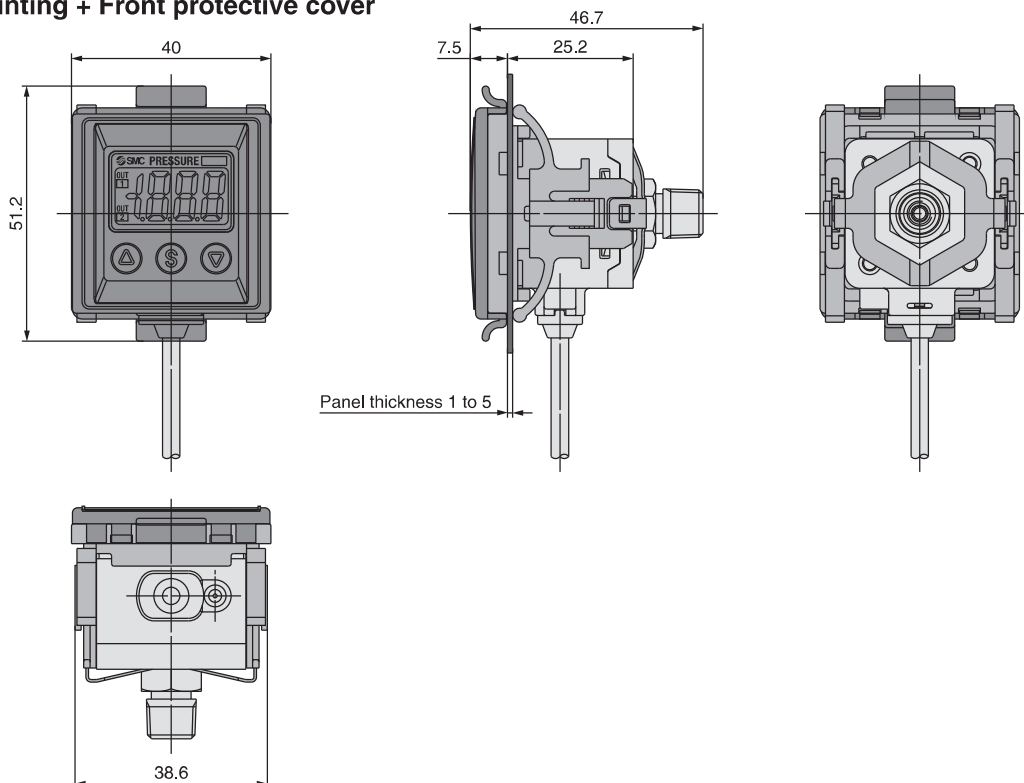

Dimensions

ZSE40A(F)/ISE40A-W1-□-□E□
-WF1-□-□E□

Panel mounting

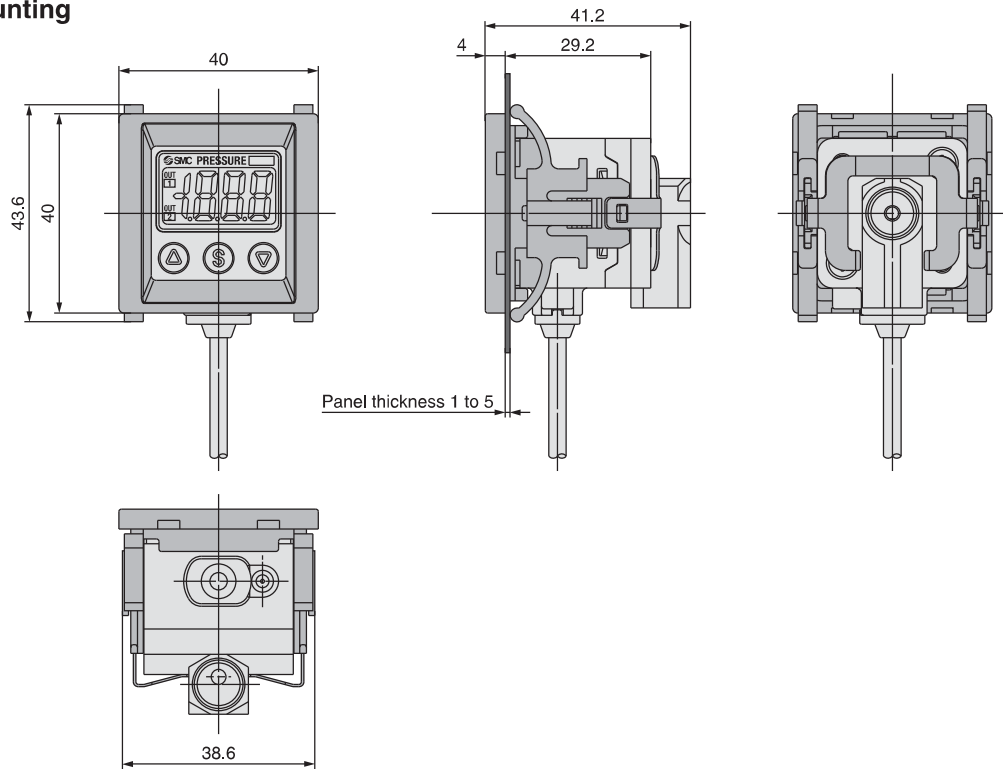

ZSE40A(F)/ISE40A-W1-□-□F□
-WF1-□-□F□

Panel mounting + Front protective cover

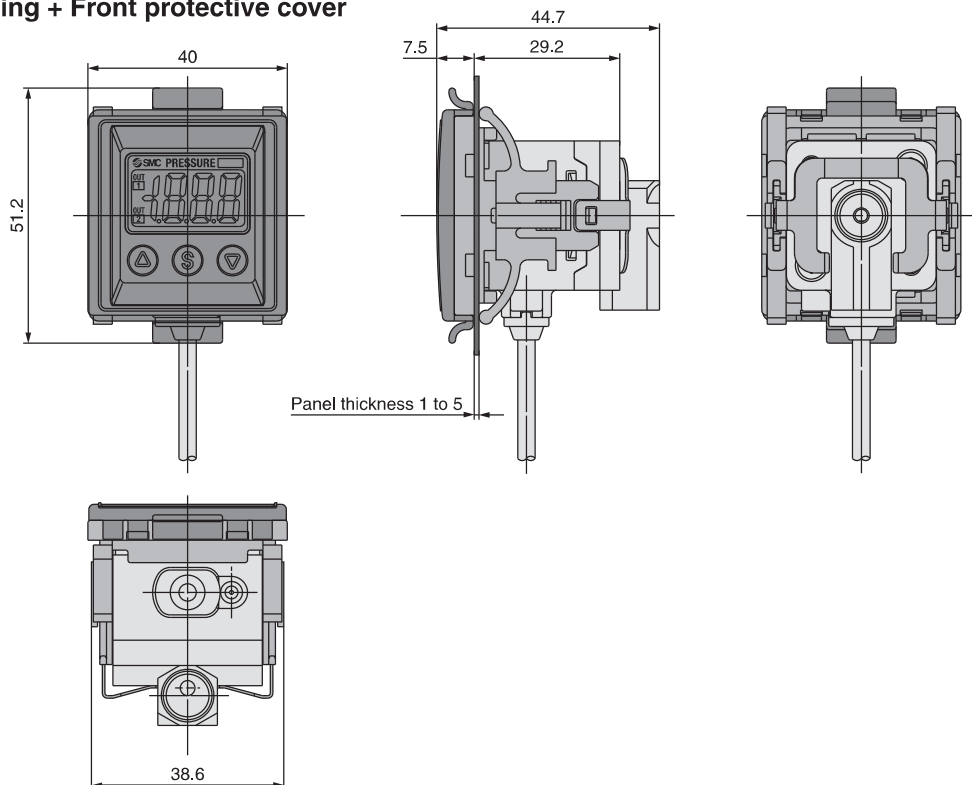

Series ZSE40A(F)/ISE40A

Dimensions

ZSE40A(F)/ISE40A-C4-□E□
-C6-□E□

Panel mounting

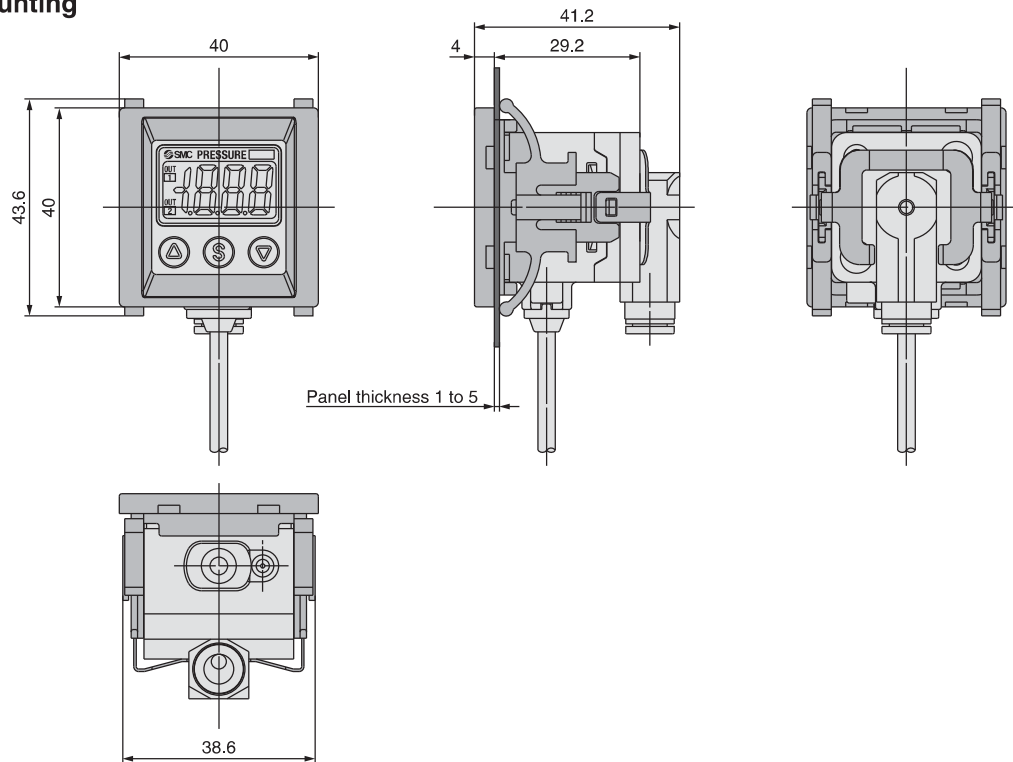

ZSE40A(F)/ISE40A-C4-□F□
-C6-□F□

Panel mounting + Front protective cover

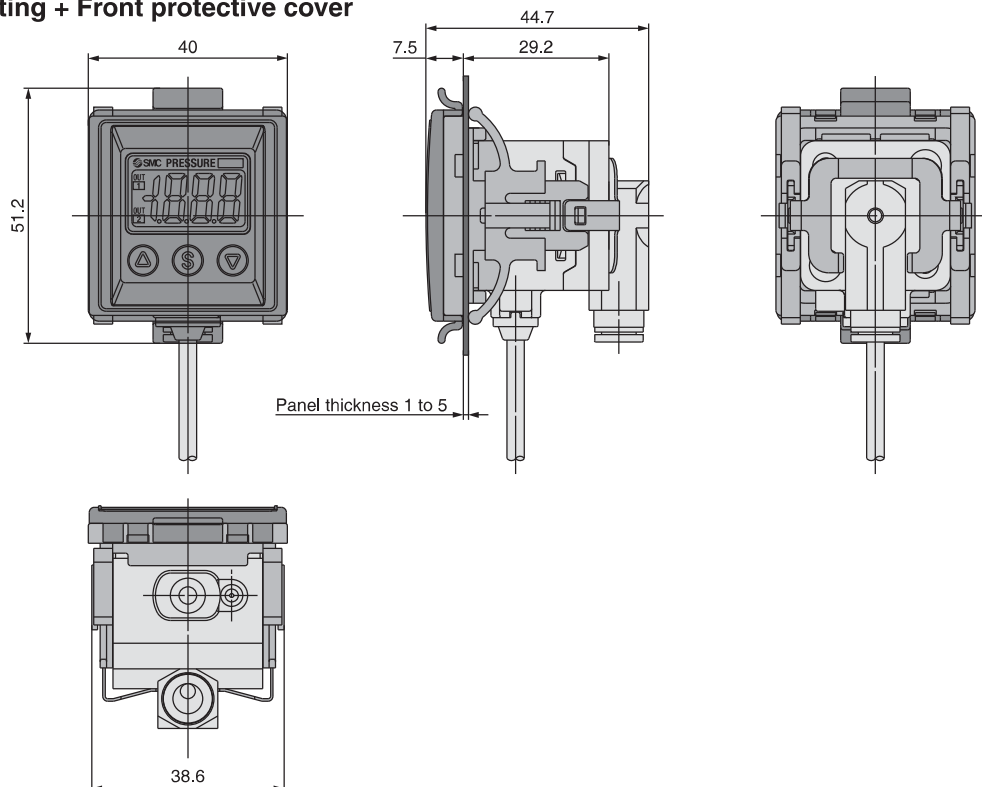

Dimensions

Panel fitting dimensions

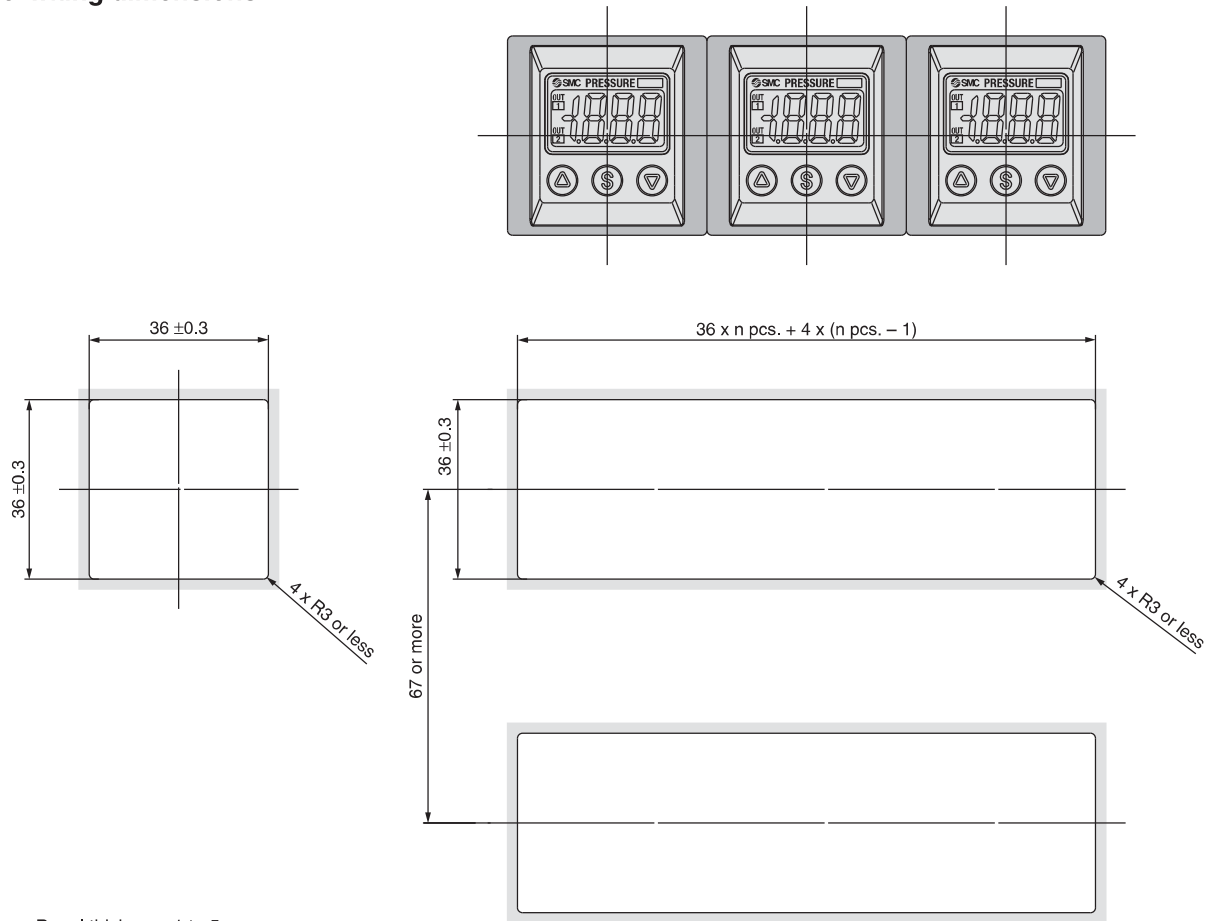

Note) This is the minimum value for the piping method O1 or N01.
Take the piping material and tubing into account for design. When the corner is to have radius, it must be R3 or less.

Function Details

A Copy function (F97)

The settings of the master pressure switch can be copied to the slave pressure switches. This can reduce the labor for setting and prevent the entry of incorrect set-values.

The set-value can be copied to up to 10 switches simultaneously.

(Maximum communication distance 4 m)

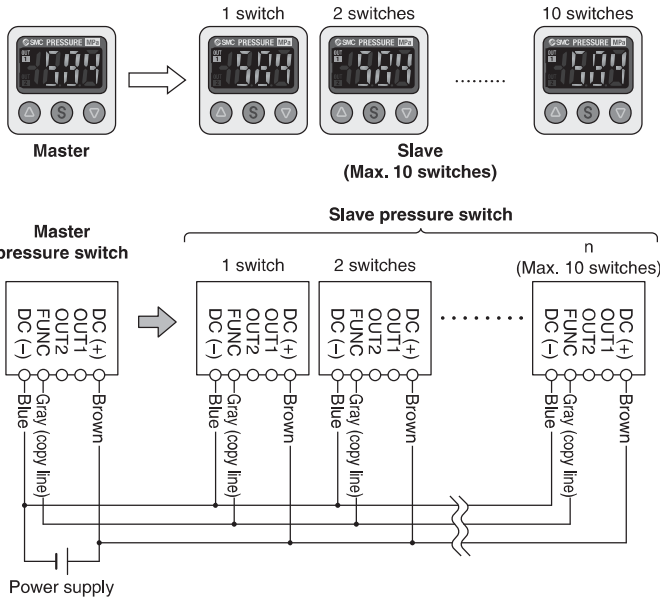

- 1) Wire as shown in the left figure.
- 2) Select the slave switch which is to be the master, and change it into a master using the buttons. (In the default setting, all switches are set as slaves.)
- 3) Press the **S** button of the master switch to start copying.

B Auto-preset function (F 4)

Auto-preset function, when selected in the initial setting, calculates and stores the set-value from the measured pressure.

The optimum set-value is determined automatically by repeating vacuum and break with the target work piece several times.

Suction Verification

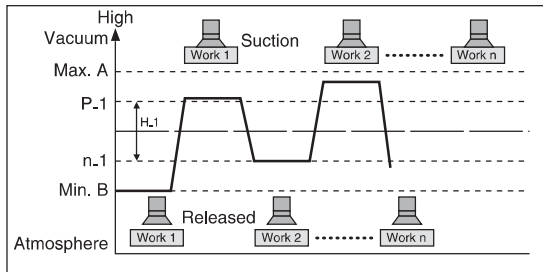

Formula for Obtaining the Set-Value

P ₋₁ or P ₋₂	H ₋₁ or H ₋₂
$P_{-1} (P_{-2}) = A - (A-B)/4$	$H_{-1} (H_{-2}) = (A-B)/2$
$n_{-1} (n_{-2}) = B + (A-B)/4$	

C Display calibration function (F 6)

Fine adjustment of the indicated value of the pressure sensor can be made within the range of $\pm 5\%$ of the read value.

(The scattering of the indicated value can be eliminated.)

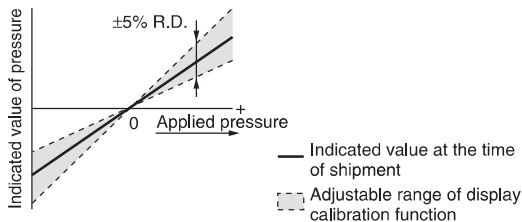

Note) When the display calibration function is used, the set pressure value may change ± 1 digit.

D Peak and bottom display function

This function constantly detects and updates the maximum (minimum) value and allows to hold the maximum (minimum) pressure value.

When the **▲** **▼** buttons are simultaneously pressed for 1 second or longer, while "holding", the hold value will be reset.

E Key lock function

This function prevents incorrect operations such as accidentally changing the set-value.

F Zero-clear function

This function clears and resets the zero value on the display of measured pressure.

For the pressure switch with analog output, the analog output shifts according to the indication. The indicated value can be adjusted within $\pm 7\%$ F.S. of the pressure when ex-factory. (ZSE40AF (for compound pressure) $\pm 3.5\%$ F.S.)

The F□ in () shows the function code number. Refer to the Operation Manual for the details of operation procedures and function codes.

G Error indication function

Error name	Error code	Description	Remedy
Overcurrent error	Er1	Load current of switch output (OUT1) exceeds 80 mA.	Turn the power off and remove the output factor for the overcurrent. Then, turn the power on.
	Er2	Load current of switch output (OUT2) exceeds 80 mA.	
Residual pressure error	Er3	During zero-clear operation, pressure over ±7% F.S. is applied. (ZSE40AF (compound) ±3.5% F.S.) After 1 second, the mode will reset to measurement mode. ±1% F.S. of the zero-clear range varies between individual products.	Perform zero-clear operation again after restoring the applied pressure to an atmospheric pressure condition.
Applied pressure error	HHH	Supply pressure exceeds the maximum set pressure.	Reset applied pressure to a level within the set pressure range.
	LLL	Supply pressure is below the minimum set pressure.	
Auto-shift error	or	The value measured at the time of auto-shift input is outside the set pressure range. * After displaying the error code for about 1 second, the switch returns to the measuring mode.	The controller does not respond to the auto-shift signal. Check the equipment and machinery for this point.
System error	Er0	Internal data error	Turn the power off and turn it on again. If the failure cannot be solved, ask SMC for repair.
	Er4		
	Er6		
	Er7		
	Er8		
	Er9		

If the above remedy cannot recover the operation, ask SMC for repair.

H Anti-chattering function (F 3)

A large bore cylinder or ejector consumes a large volume of air in operation and may experience a temporary drop in the supply pressure. This function prevents detection of such temporary drops in the supply pressure as an error.

Available response time settings
20 ms, 100 ms, 500 ms, 1000 ms, 2000 ms

<Principle>

This function averages pressure values measured during the response time set by the user and then compares the average pressure value with the pressure set point value to output the result on the switch.

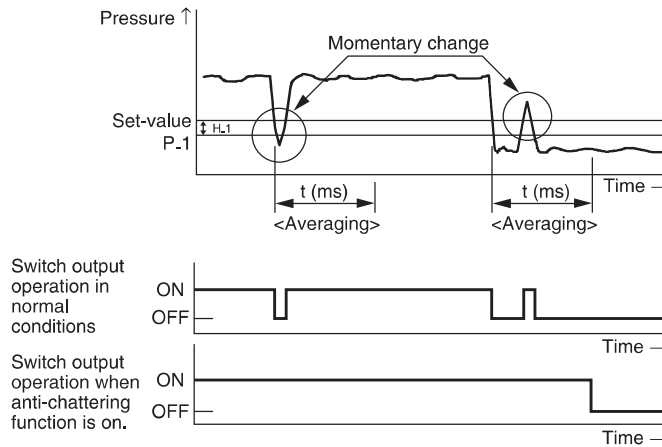

I Display unit switching function (F 0)

Display units can be switched with this function.

Display unit	PA		GF	bar	PSI	inH	mmH
	kPa	MPa*	kgf/cm ²	bar	psi	inHg	mmHg
Minimum unit setting							
ZSE40A (vacuum pressure)	0.1	0.001	0.001	0.001	0.01	0.1	1
ZSE40AF (compound pressure)	0.1	0.001	0.001	0.001	0.02	0.1	1
ISE40A (positive pressure)	1	0.001	0.01	0.01	0.1		

* The ZSE40A (vacuum pressure) and ZSE40AF (compound pressure) will have different setting and display resolution when the unit is set to MPa.

The F□ in () shows the function code number. Refer to the Operation Manual for the details of operation procedures and function codes.

Function Details

J Power-saving mode (F80)

Power-saving mode can be selected.

It shifts to the power-saving mode without button operation for 30 seconds. It is set to the normal mode (Power-saving mode is OFF.) when ex-factory. (Decimal points and operation indicator light (only when the switch output is turned ON,) blink in the power-saving mode.)

K Secret code setting (F81)

It can be set whether secret code input is required or not when key is locked. It is set to input no secret code when ex-factory.

L Auto-shift function (F 5)

When there are large fluctuations in the supply pressure, the switch may fail to operate correctly. The auto-shift function compensates such supply pressure fluctuations. It measures the pressure at the time of auto-shift signal input and uses it as the reference pressure to correct the set-value on the switch.

Set-value correction by auto-shift function

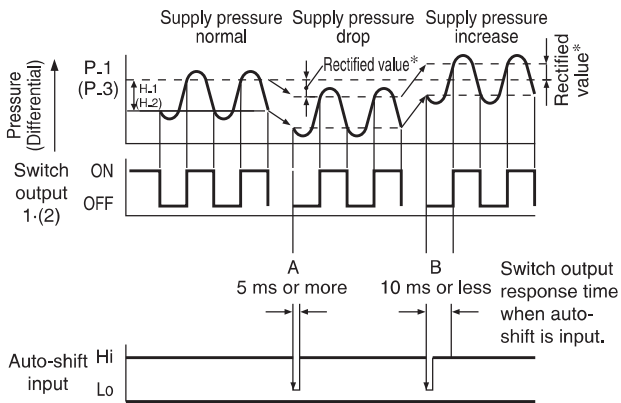

* Rectified value

When the auto-shift is selected, "000" will be displayed for about 1 second, and the pressure value at that point will be saved as a rectified value "000". Based on the saved rectified values, the set-value of "P-1", "P-2", "H-1", and "H-2" will likewise be rectified.

Note) When an output is reversed, "n-1", "H-1", "n-2", "H-2" will be rectified.

Possible Set Range for Auto-Shift Input

	Regulating pressure range	Possible set range
Compound pressure	-15.22 to 15.22 psi	-30.4 to 30.4 psi
Vacuum pressure	1.45 to -15.23 psi	16.68 to -16.68 psi
Positive pressure	-15.2 to 152.3 psi	-167.5 to 167.5 psi

Auto-shift zero

The basic function of auto-shift zero is the same as the function for auto-shift. Also, it corrects values on the display, based on a pressure value of "0", when the auto-shift is selected.

Series ZSE40A(F)/ISE40A

Made to Order



Please contact SMC for detailed dimensions, specifications, and lead times.

1 Lead wire length 3 m

Symbol
-X501

Lead wire is 3 meters.

How to Order



* Refer to How to Order on page 1 for standard specifications.

ZSE40A(F)/ISE40A - [] - [] - [] - X501

Piping specifications*

Output specifications*

Option*

2 M12 4-pin pre-wired connector

Symbol
-X531

How to Order

ZSE40A(F)/ISE40A - [] - [] - [] - X531

Output specifications

X: NPN open collector 2 outputs

Y: PNP open collector 2 outputs

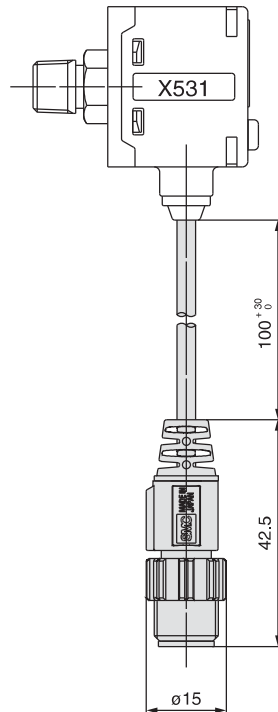

Pin arrangement

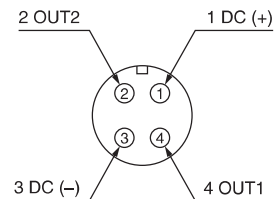





Safety Instructions

These safety instructions are intended to prevent hazardous situations and/or equipment damage. These instructions indicate the level of potential hazard with the labels of “**Caution**,” “**Warning**” or “**Danger**.” They are all important notes for safety and must be followed in addition to International Standards (ISO/IEC), American National Standards Institute (ANSI)*1) and other safety regulations.

- *1) ISO 4414: Pneumatic fluid power – General rules relating to systems.
ISO 4413: Hydraulic fluid power – General rules relating to systems.
IEC 60204-1: Safety of machinery – Electrical equipment of machines. (Part 1: General requirements)
ISO 10218-1: Manipulating industrial robots - Safety.
ANSI / (NFPA) T2.25.1 R2: Pneumatic fluid power - Systems standard for industrial machinery.
NFPA (Fluid) T2.24.1 R1: Hydraulic fluid power - Systems standard for stationary industrial machinery.
NFPA 79: Electrical Standard for Industrial Machinery.
ANSI / RIA / ISO 10218 -1: Robots for Industrial Environment - Safety Requirements - Part 1 - Robot.
etc.

-  **Caution:** **Caution** indicates a hazard with a low level of risk which, if not avoided, could result in minor or moderate injury.
-  **Warning:** **Warning** indicates a hazard with a medium level of risk which, if not avoided, could result in death or serious injury.
-  **Danger :** **Danger** indicates a hazard with a high level of risk which, if not avoided, will result in death or serious injury.

Warning

1. The compatibility of the product is the responsibility of the person who designs the equipment or decides its specifications.

Since the product specified here is used under various operating conditions, its compatibility with specific equipment must be decided by the person who designs the equipment or decides its specifications based on necessary analysis and test results. The expected performance and safety assurance of the equipment will be the responsibility of the person who has determined its compatibility with the product. This person should also continuously review all specifications of the product referring to its latest catalog information, with a view to giving due consideration to any possibility of equipment failure when configuring the equipment.

2. Only personnel with appropriate training should operate machinery and equipment.

The product specified here may become unsafe if handled incorrectly. The assembly, operation and maintenance of machines or equipment including our products must be performed by an operator who is appropriately trained and experienced.

3. Do not service or attempt to remove product and machinery/equipment until safety is confirmed.

1. The inspection and maintenance of machinery/equipment should only be performed after measures to prevent falling or runaway of the driven objects have been confirmed.
2. When the product is to be removed, confirm that the safety measures as mentioned above are implemented and the power from any appropriate source is cut, and read and understand the specific product precautions of all relevant products carefully.
3. Before machinery/equipment is restarted, take measures to prevent unexpected operation and malfunction.

4. Contact SMC beforehand and take special consideration of safety measures if the product is to be used in any of the following conditions.

1. Conditions and environments outside of the given specifications, or use outdoors or in a place exposed to direct sunlight.
2. Installation on equipment in conjunction with atomic energy, railways, air navigation, space, shipping, vehicles, military, medical treatment, combustion and recreation, or equipment in contact with food and beverages, emergency stop circuits, clutch and brake circuits in press applications, safety equipment or other applications unsuitable for the standard specifications described in the product catalog.
3. An application which could have negative effects on people, property, or animals requiring special safety analysis.
4. Use in an interlock circuit, which requires the provision of double interlock for possible failure by using a mechanical protective function, and periodical checks to confirm proper operation.



Safety Instructions

Caution

1. The product is provided for use in manufacturing industries.

The product herein described is basically provided for peaceful use in manufacturing industries.

If considering using the product in other industries, consult SMC beforehand and exchange specifications or a contract if necessary.

If anything is unclear, contact your nearest sales branch.

Limited warranty and Disclaimer/Compliance Requirements

The product used is subject to the following “Limited warranty and Disclaimer” and “Compliance Requirements”. Read and accept them before using the product.

Limited warranty and Disclaimer

1. The warranty period of the product is 1 year in service or 1.5 years after the product is delivered.*2)
Also, the product may have specified durability, running distance or replacement parts. Please consult your nearest sales branch.
2. For any failure or damage reported within the warranty period which is clearly our responsibility, a replacement product or necessary parts will be provided.
This limited warranty applies only to our product independently, and not to any other damage incurred due to the failure of the product.
3. Prior to using SMC products, please read and understand the warranty terms and disclaimers noted in the specified catalog for the particular products.

***2) Vacuum pads are excluded from this 1 year warranty.**

A vacuum pad is a consumable part, so it is warranted for a year after it is delivered.

Also, even within the warranty period, the wear of a product due to the use of the vacuum pad or failure due to the deterioration of rubber material are not covered by the limited warranty.

Compliance Requirements

1. The use of SMC products with production equipment for the manufacture of weapons of mass destruction (WMD) or any other weapon is strictly prohibited.
2. The exports of SMC products or technology from one country to another are governed by the relevant security laws and regulations of the countries involved in the transaction. Prior to the shipment of a SMC product to another country, assure that all local rules governing that export are known and followed.



Series ZSE40A(F)/ISE40A Specific Product Precautions 1

Be sure to read before handling.

Refer to back pages 1 and 2 for Safety Instructions, “Handling Precautions for SMC Products” (M-E03-3) for Pressure Switches Precautions.

Handling

⚠ Caution

1. Do not drop, bump, or apply excessive impacts (100 m/s²) while handling. Although the body of the sensor may not be damaged, the internal parts of the sensor could be damaged and lead to a malfunction.
2. The tensile strength of the cord is 49 N. Applying a greater pulling force on it can cause a malfunction. When handling, hold the body of the sensor—do not dangle it from the cord.
3. Do not exceed the screw-in torque of 7 to 9 N·m when connecting the pipe to the switch. Exceeding this torque may cause the switch to malfunction.
4. Do not use pressure sensors with corrosive and/or flammable gases or liquids.

Connection

⚠ Caution

1. Incorrect wiring can damage the switch and cause a malfunction or erroneous switch output.
2. Connections should be done while the power is turned off.
3. Wire separately from power lines and high voltage lines, avoiding wiring in the same conduit with these lines. Malfunctions may occur due to noise from these other lines.
4. If a commercial switching regulator is used, make sure that the F.G. terminal is grounded.

Operating Environment

⚠ Warning

1. This pressure switch is CE marked; however, it is not equipped with surge protection against lightning. Lightning surge countermeasures should be applied directly to system components as necessary.
2. This pressure switch does not have an explosion proof rating. Never use in the presence of an explosive gas as this may cause a serious explosion.

Operating Environment

⚠ Caution

1. Do not use the product in a place where it could be splashed by oils or solvents.
2. When this pressure switch is used in a place where water and dust splash on, water and dust may enter inside the switch through the atmospheric vent port. Insert a $\phi 4$ tube (I.D. $\phi 2.5$) into the atmospheric vent port, and bring piping of the opposite side up to the safe position to keep it from water and dust. Do not bend the tube or close the hole of it. It causes malfunction with the measurement of positive pressure.

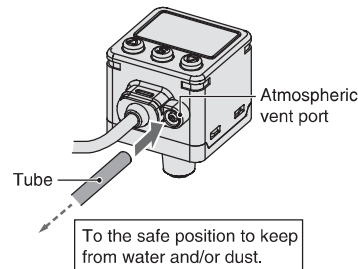

- * Make sure that the tube is inserted to the end of the atmospheric vent port.
- * Use SMC tubing, TU0425. (Material: Polyurethane, Tube O.D. $\phi 4$, I.D. $\phi 2.5$)

3. Take measures against static electricity with equipment when this switch is used in connection with resin piping. Also, the ground should be separate from that of the units that generate strong electromagnetic noise or high frequency, otherwise, the switch can be damaged by static electricity.



Series ZSE40A(F)/ISE40A Specific Product Precautions 2

Be sure to read before handling.

Refer to back pages 1 and 2 for Safety Instructions, "Handling Precautions for SMC Products" (M-E03-3) for Pressure Switches Precautions.

Mounting

Caution

1. Mounting with panel mount adapter

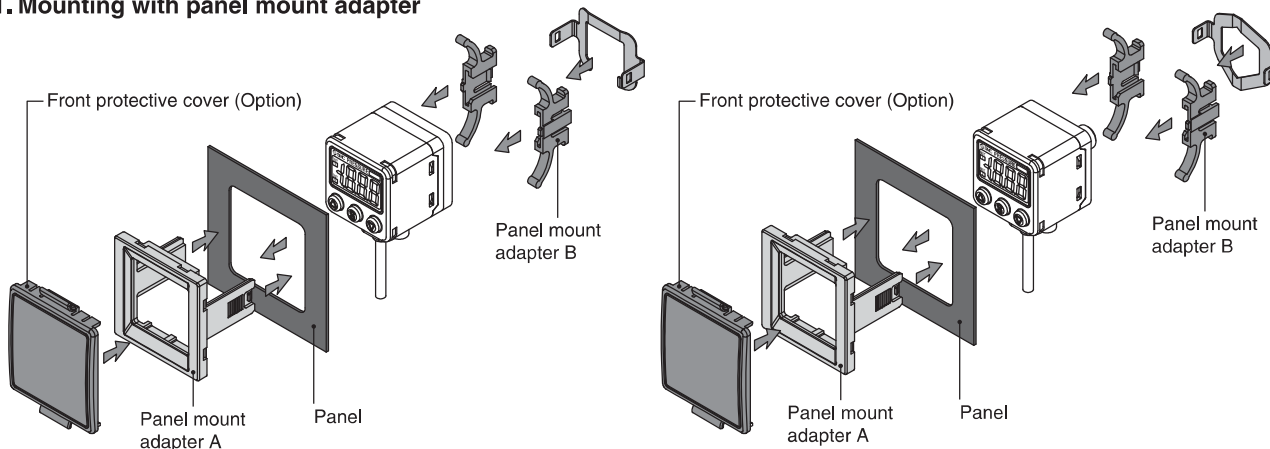

2. Mounting with bracket

Mount a bracket to the using two mounting screws and install on piping. The switch can be installed horizontally depending on the installation location.

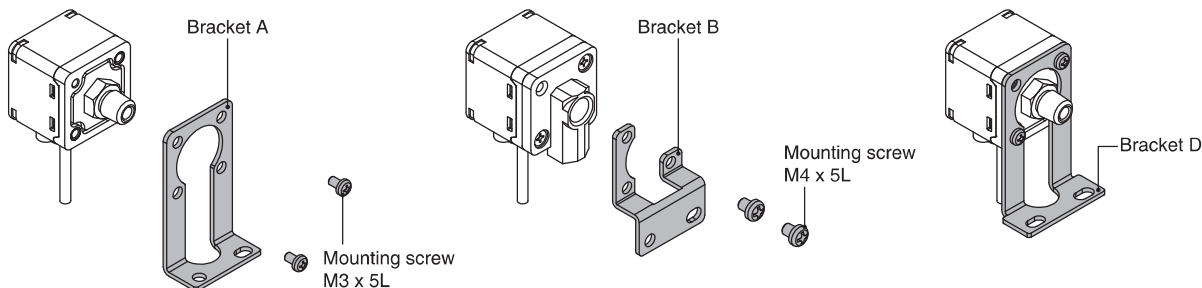

The tightening torque for bracket mounting screw should be 0.5 to 0.7 N·m for M3 and 1.4 to 1.6 N·m for M4.

Set Pressure Range and Rated Pressure Range

Caution

Set the pressure within the rated pressure range.

The set pressure range is the range of pressure that is possible in setting.

The rated pressure range is the range of pressure that satisfies the specifications (accuracy, linearity, etc.) on the switch.

Although it is possible to set a value outside the rated pressure range, the specifications will not be guaranteed even if the value stays within the set pressure range.

Switch	Pressure range				
	-14.5 psi	0	14.5 psi	72.5 psi	145 psi
For vacuum pressure ZSE40A	-14.69 psi	0			
	-15.23 psi	1.45 psi			
For compound pressure ZSE40AF	-14.5 psi		14.5 psi		
	-15.22 psi		15.22 psi		
For positive pressure ISE40A	-14.5 psi				145 psi
	-15.2 psi				152.3 psi

Rated pressure range of switch
 Set pressure range of switch

Related Equipment

2-Color Display High Precision Digital Pressure Switch *ZSE/ISE30A*



Series	Type	Rated pressure range
ZSE30AF	Compound pressure	-14.50 to 14.50 psi
ZSE30A	Low pressure/vacuum	0.00 to -14.65 psi
ISE30A	Positive pressure	-14.5 to 145.0 psi
Features	<ul style="list-style-type: none"> • With one-touch fitting (Straight, Elbow) • Space-saving, capable of vertical and horizontal contact mounting • With display calibration function • Simultaneous copying is possible for maximum 10 units. • IP40 	

2-Color Display Digital Pressure Switch *ZSE/ISE80*



Series	Type	Rated pressure range
ZSE80F	Compound pressure	-14.50 to 14.50 psi
ZSE80	Vacuum pressure	0.00 to -14.65 psi
ISE80	Positive pressure	-14.5 to 145.0 psi
ISE80H	Positive pressure	-14.5 to 290 psi
Features	<ul style="list-style-type: none"> • Suitable for a wide variety of fluids with stainless diaphragm • IP65 • RoHS compliant • Low leakage. VCR®, Swagelok® compatible fittings can be selected. • With one-touch fittings (Straight, Elbow) • Back piping, underside piping 	

* VCR® and Swagelok® are trademarks of Swagelok Company.

Global Manufacturing, Distribution and Service Network

Worldwide Subsidiaries

EUROPE

AUSTRIA
SMC Pneumatik GmbH (Austria)

BELGIUM
SMC Pneumatics N.V./S.A.

BULGARIA
SMC Industrial Automation Bulgaria EOOD

CROATIA
SMC Industrijska Automatika d.o.o.

CZECH
SMC Industrial Automation CZ s.r.o.

DENMARK
SMC Pneumatik A/S

ESTONIA
SMC Pneumatics Estonia

FINLAND
SMC Pneumatics Finland OY

FRANCE
SMC Pneumatique S.A.

GERMANY
SMC Pneumatik GmbH

GREEK
SMC Hellas EPE

HUNGARY
SMC Hungary Ipari Automatizálási Kft.

IRELAND
SMC Pneumatics (Ireland) Ltd.

ITALY
SMC Italia S.p.A.

LATVIA
SMC Pneumatics Latvia SIA

LIETUVA
SMC Pneumatics Lietuva, UAB

NETHERLANDS
SMC Pneumatics BV

NORWAY
SMC Pneumatics Norway A/S

POLAND
SMC Industrial Automation Polska Sp.z.o.o.

ROMANIA
SMC Romania S.r.l.

RUSSIA
SMC Pneumatik LLC.

SLOVAKIA
SMC Priemyselna Automatizacia, s.r.o.

SLOVENIA
SMC Industrijska Avtomatika d.o.o.

SPAIN/PORTUGAL
SMC España, S.A.

SWEDEN
SMC Pneumatics Sweden AB

SWITZERLAND
SMC Pneumatik AG

UK
SMC Pneumatics (U.K.) Ltd.

ASIA

CHINA
SMC (China) Co., Ltd.

HONG KONG
SMC Pneumatics (Hong kong) Ltd.

INDIA
SMC Pneumatics (India) Pvt. Ltd.

JAPAN
SMC Corporation

MALAYSIA
SMC Pneumatics (S.E.A.) Sdn. Bhd.

PHILIPPINES
SMC Pneumatics (Philippines), Inc.

SINGAPORE
SMC Pneumatics (S.E.A.) Pte. Ltd.

SOUTH KOREA
SMC Pneumatics Korea Co., Ltd.

TAIWAN
SMC Pneumatics (Taiwan) Co., Ltd.

THAILAND
SMC Thailand Ltd.

NORTH AMERICA

CANADA
SMC Pneumatics (Canada) Ltd.

MEXICO
SMC Corporation (Mexico) S.A. DE C.V.

USA
SMC Corporation of America

SOUTH AMERICA

ARGENTINA
SMC Argentina S.A.

BOLIVIA
SMC Pneumatics Bolivia S.R.L.

BRAZIL
SMC Pneumaticos do Brazil Ltda.

CHILE
SMC Pneumatics (Chile) S.A.

VENEZUELA
SMC Neumatica Venezuela S.A.

OCEANIA

AUSTRALIA
SMC Pneumatics (Australia) Pty. Ltd.

NEW ZEALAND
SMC Pneumatics (N.Z.) Ltd.

U.S. & Canadian Sales Offices

EAST

Atlanta
Boston
Charlotte
Nashville
New Jersey
Richmond
Rochester
Tampa

WEST

Austin
Dallas
Los Angeles
Phoenix
Portland
San Francisco

MIDWEST

Chicago
Cincinnati
Cleveland
Detroit
Indianapolis
Milwaukee
Minneapolis
St. Louis

CANADA

Montreal
Toronto
Vancouver
Windsor

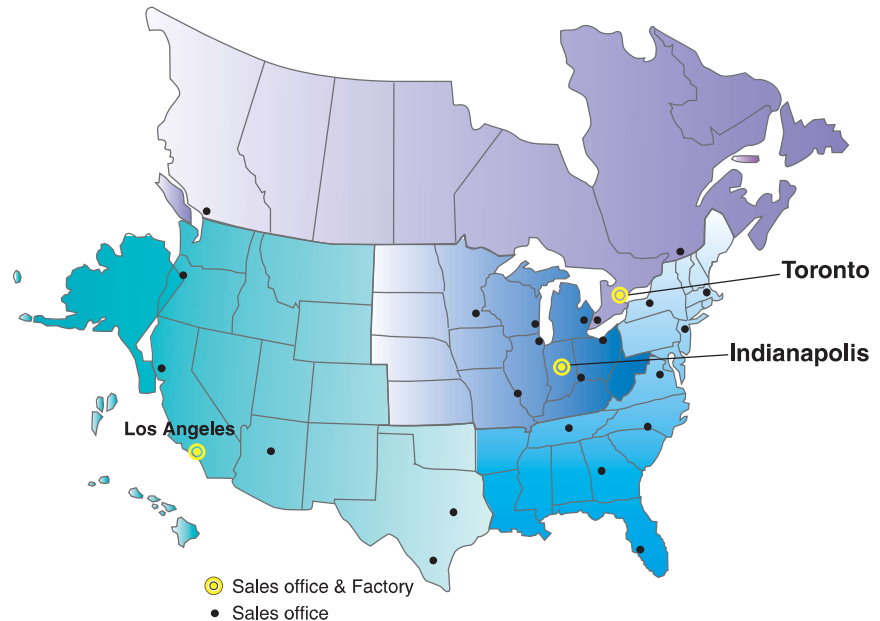

SMC Corporation of America
10100 SMC Blvd., Noblesville, IN 46060 www.smcusa.com
(800) SMC.SMC1 (762-7621)
For International inquires: www.smcworld.com