

























Pressure sensor, Series PE5

- Operating pressure -14.5 ... 0, -14.5 ... 14, 0 ... 87, 0 ... 145, 0 ... 174 psi
- electronic
- Output signal analog 4 ... 20 mA
- Output signal digital 2 outputs, 1 output
- IO-Link
- Electr. connection Plug, M12x1, 4-pin
- Compressed air connection Internal thread, G 1/4, push-in fitting, Ø 4



Type	electronic
Certificates	CE declaration of conformity, cULus, RoHS, Conforms with REACH, Free of substances that impair surface wetting in the coating process
Ambient temperature min./max.	32 ... 140 °F
Medium temperature min./max.	32 ... 140 °F
Medium	Compressed air (max. 40 µm)
Max. oil content of compressed air	40 mg/m ³
Measurement	Relative pressure
Display	LCD display, 4 digits, Color setting: green or red
Units displayed	bar, psi, kPa, MPa, inHg
Switching logic	NO/NC (adjustable)
Shock resistance max.	30 g
Vibration resistance	5 g (10 - 150 Hz)
Precision (% of full scale value)	±1.5% in temperature range of 10 - 30°C, ± 2 % including temperature drift
Repeatability (% of full scale value)	± 0,2 %
Switching time	5 ms
Switching point	adjustable 0 ... 100%
Resetting point	adjustable 0 ... 100%
Hysteresis	adjustable
Delayed hysteresis	adjustable
Window function	adjustable
DC operating voltage,min./max.	17 ... 30 V DC
Analog output	0 - 10 V DC, 4 - 20 mA
Quiescent current consumption	40 mA
Analog output linearity	± 0.5% of the final value
Maximum load (analog current output)	600 Ω
Short circuit resistance	Max. 600 ohms (current output), Min. 3K ohms (voltage output)
Mounting types	Directly on hat rail and wall mounting, For panel installation using mounting kit, via double nipple
Protection class	IP65, IP67 with connections assembled
Electr. connection	Plug, M12x1, 4-pin
Weight	0.088 lbs

Technical data

Part No.		Operating pressure range	Protection against overpressure
		min./max.	
R412010761		-14.5 ... 0 psi	72.5 psi
R412010760		-14.5 ... 0 psi	72.5 psi
R412010769		-14.5 ... 0 psi	72.5 psi
R412010768		-14.5 ... 0 psi	72.5 psi
R412010775		-14.5 ... 0 psi	72.5 psi
R412010774		-14.5 ... 0 psi	72.5 psi
R412010763		-14.5 ... 14 psi	72.5 psi
R412010762		-14.5 ... 14 psi	72.5 psi
R412010771		0 ... 87 psi	217.5 psi
R412010770		0 ... 87 psi	217.5 psi
R412010765		0 ... 87 psi	217.5 psi
R412010764		0 ... 87 psi	217.5 psi
R412010777		0 ... 87 psi	217.5 psi
R412010776		0 ... 87 psi	217.5 psi
R412010773		0 ... 145 psi	217.5 psi
R412010772		0 ... 145 psi	217.5 psi
R412010767		0 ... 145 psi	217.5 psi
R412010766		0 ... 145 psi	217.5 psi
R412010779		0 ... 145 psi	217.5 psi
R412010778		0 ... 145 psi	217.5 psi
R412010782		0 ... 174 psi	232 psi
R412010781		0 ... 174 psi	232 psi
R412010806		0 ... 174 psi	232 psi
R412010805		0 ... 174 psi	232 psi

Part No.	Output signal	Output signal
	Analog	digital
R412010761	-	2 outputs-PNP, NPN, Push-pull
R412010760	-	2 outputs-PNP, NPN, Push-pull
R412010769	1 output-0 - 10 V DC-4 ... 20 mA	1 output-PNP, NPN, Push-pull
R412010768	1 output-0 - 10 V DC-4 ... 20 mA	1 output-PNP, NPN, Push-pull
R412010775	-	1 output-PNP, NPN, push-pull, 1x IO-Link
R412010774	-	1 output-PNP, NPN, push-pull, 1x IO-Link
R412010763	-	2 outputs-PNP, NPN, Push-pull
R412010762	-	2 outputs-PNP, NPN, Push-pull
R412010771	1 output-0 - 10 V DC-4 ... 20 mA	1 output-PNP, NPN, Push-pull
R412010770	1 output-0 - 10 V DC-4 ... 20 mA	1 output-PNP, NPN, Push-pull
R412010765	-	2 outputs-PNP, NPN, Push-pull
R412010764	-	2 outputs-PNP, NPN, Push-pull
R412010777	-	1 output-PNP, NPN, push-pull, 1x IO-Link
R412010776	-	1 output-PNP, NPN, push-pull, 1x IO-Link
R412010773	1 output-0 - 10 V DC-4 ... 20 mA	1 output-PNP, NPN, Push-pull
R412010772	1 output-0 - 10 V DC-4 ... 20 mA	1 output-PNP, NPN, Push-pull
R412010767	-	2 outputs-PNP, NPN, Push-pull
R412010766	-	2 outputs-PNP, NPN, Push-pull
R412010779	-	1 output-PNP, NPN, push-pull, 1x IO-Link

Part No.	Output signal	
	Analog	digital
R412010778	-	1 output-PNP, NPN, push-pull, 1x IO-Link
R412010782	-	2 outputs-PNP, NPN, Push-pull
R412010781	-	2 outputs-PNP, NPN, Push-pull
R412010806	-	1 output-PNP, NPN, push-pull, 1x IO-Link
R412010805	-	1 output-PNP, NPN, push-pull, 1x IO-Link

Part No.	Compressed air connection	Fig.
R412010761	Internal thread, G 1/4	Fig. 1
R412010760	push-in fitting, Ø 4	Fig. 2
R412010769	Internal thread, G 1/4	Fig. 1
R412010768	push-in fitting, Ø 4	Fig. 2
R412010775	Internal thread, G 1/4	Fig. 1
R412010774	push-in fitting, Ø 4	Fig. 2
R412010763	Internal thread, G 1/4	Fig. 1
R412010762	push-in fitting, Ø 4	Fig. 2
R412010771	Internal thread, G 1/4	Fig. 1
R412010770	push-in fitting, Ø 4	Fig. 2
R412010765	Internal thread, G 1/4	Fig. 1
R412010764	push-in fitting, Ø 4	Fig. 2
R412010777	Internal thread, G 1/4	Fig. 1
R412010776	push-in fitting, Ø 4	Fig. 2
R412010773	Internal thread, G 1/4	Fig. 1
R412010772	push-in fitting, Ø 4	Fig. 2
R412010767	Internal thread, G 1/4	Fig. 1
R412010766	push-in fitting, Ø 4	Fig. 2
R412010779	Internal thread, G 1/4	Fig. 1
R412010778	push-in fitting, Ø 4	Fig. 2
R412010782	Internal thread, G 1/4	Fig. 1
R412010781	push-in fitting, Ø 4	Fig. 2
R412010806	Internal thread, G 1/4	Fig. 1
R412010805	push-in fitting, Ø 4	Fig. 2

Technical information

Alternative pressure connection (G1/4) on the rear side (closed with plug)

Display color selectable, red or green

The IO-Link device description (IODD) for the PE5 pressure sensor is available for download in the Media Centre.

Technical information

Material	
Housing	Polycarbonate
Seals	Acrylonitrile butadiene rubber
Blanking plug	Polyoxymethylene
Electr. connection	Aluminum, black anodized

Dimensions

Fig. 1

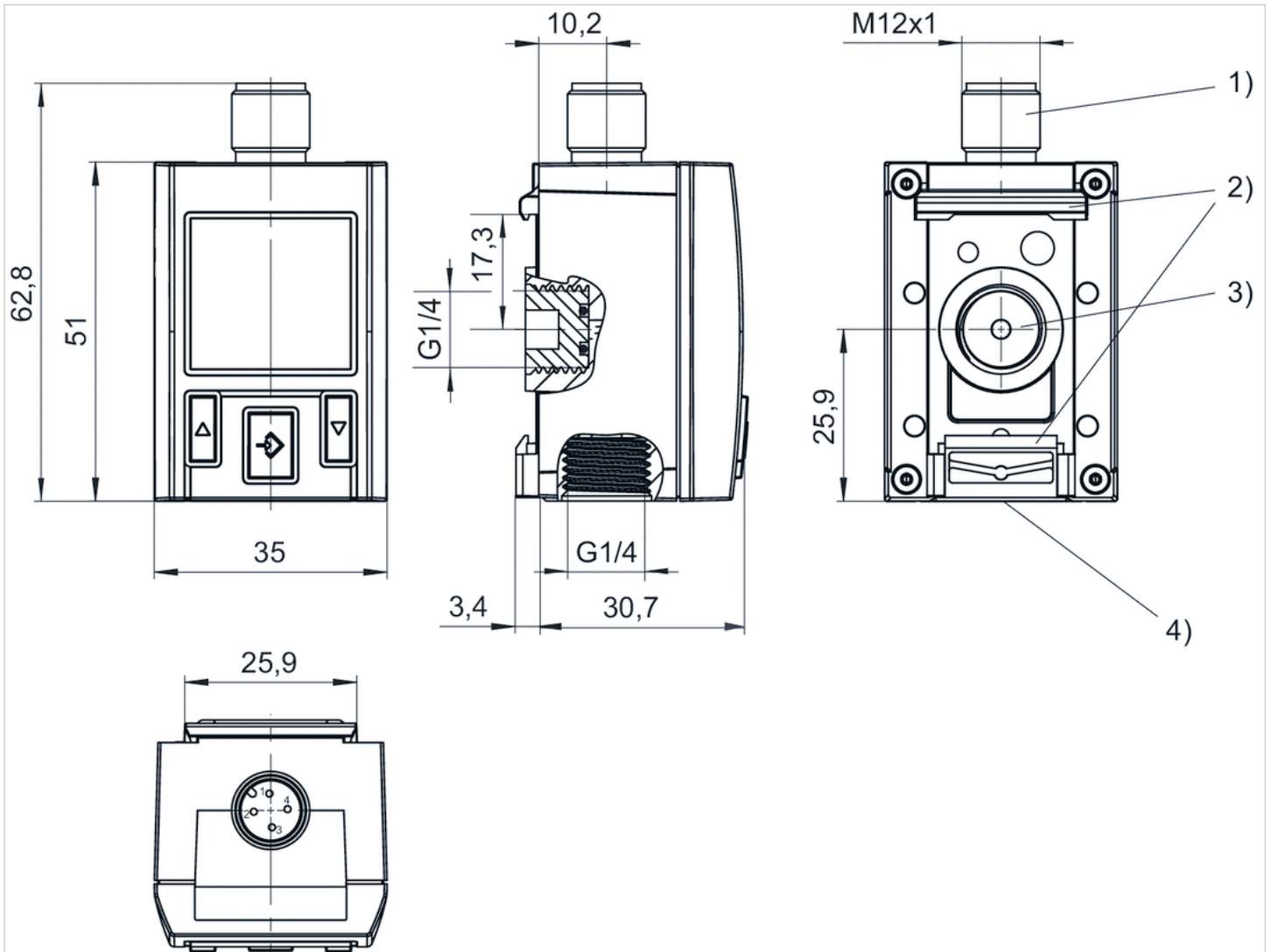

- 1) M12x1 electrical connection
- 2) Mounting for hat rail and wall mounting
- 3) Alternative pressure connection (G1/4) closed with plug
- 4) Pressure connection G1/4

Fig. 2

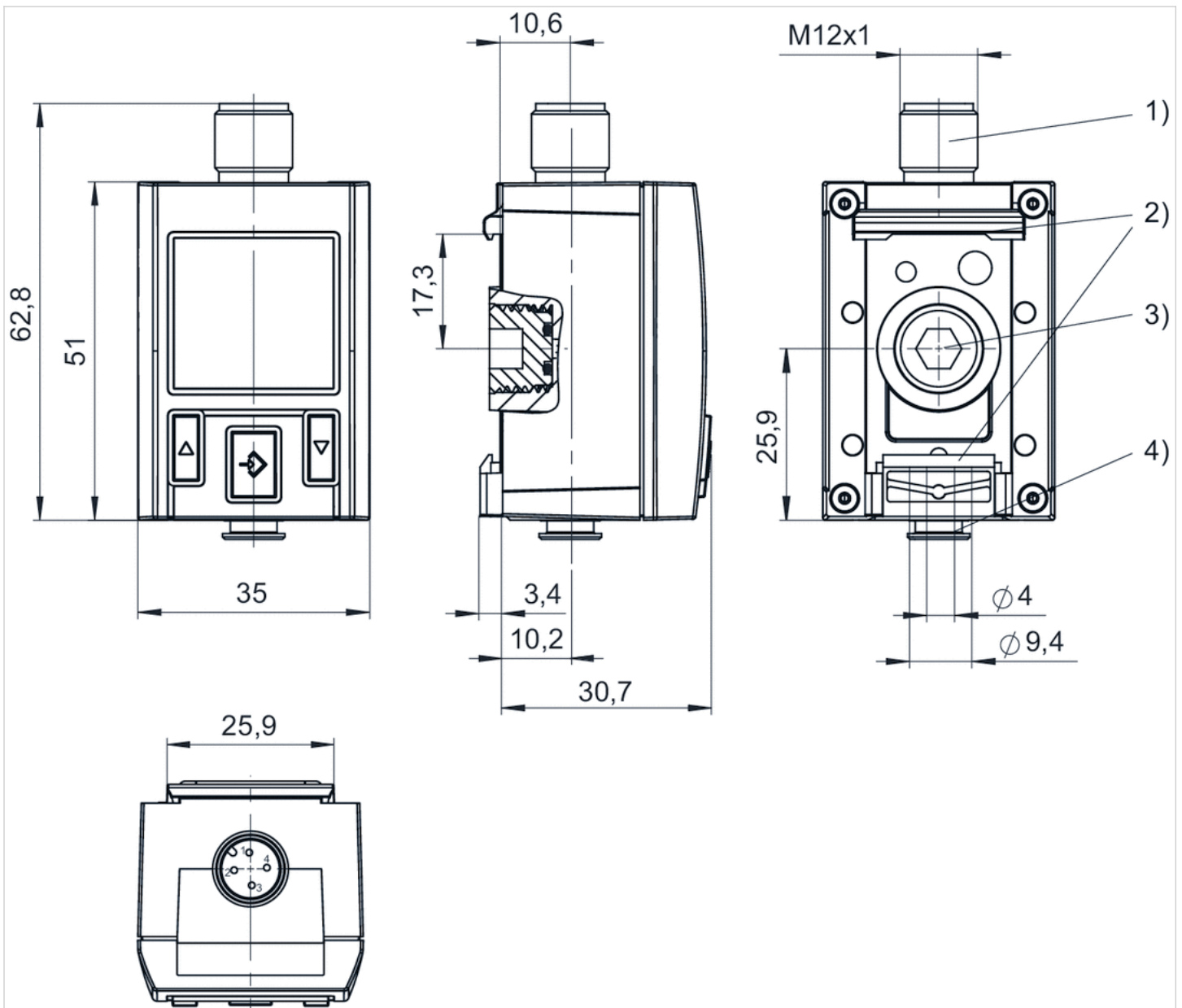

- 1) M12x1 electrical connection
- 2) Mounting for hat rail and wall mounting
- 3) Alternative pressure connection (G1/4) closed with plug
- 4) Pressure connection, tubing \varnothing 4 mm

Display and operation area

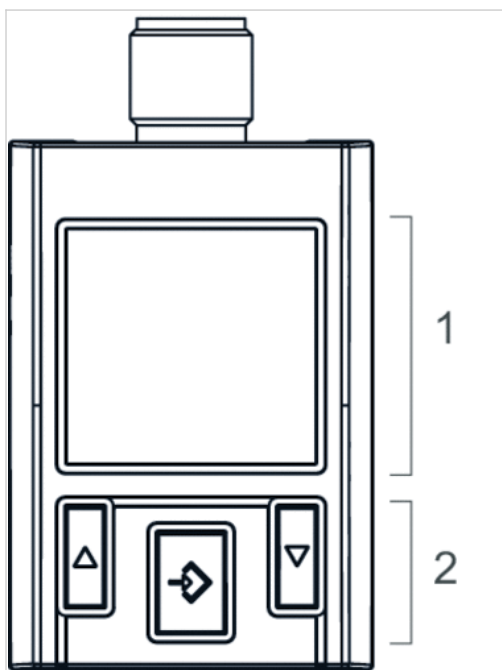

- 1) LCD display
- 2) Control panel with 3 buttons

Diagrams

Operating mode PNP

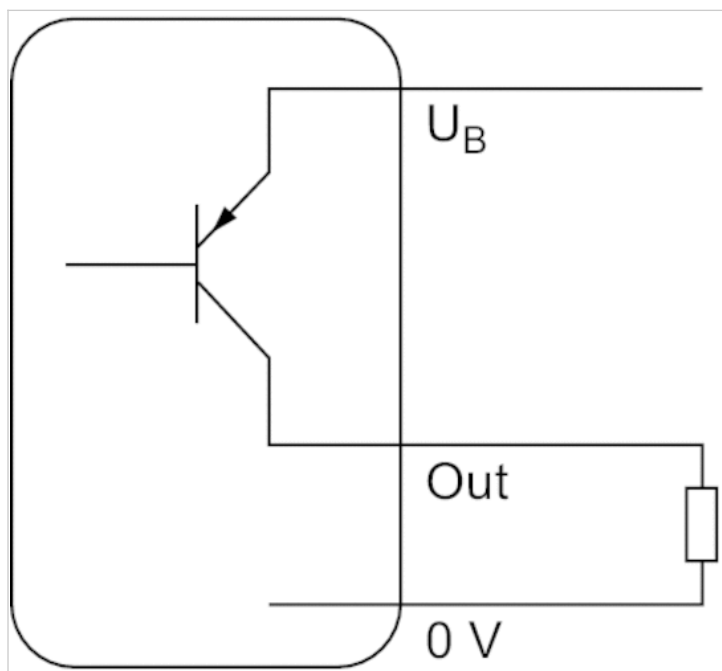

Operating mode NPN

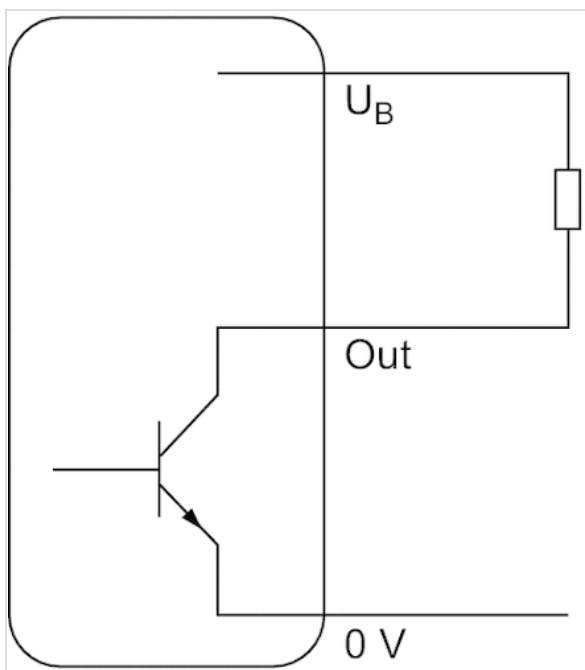

Operating mode Push-pull

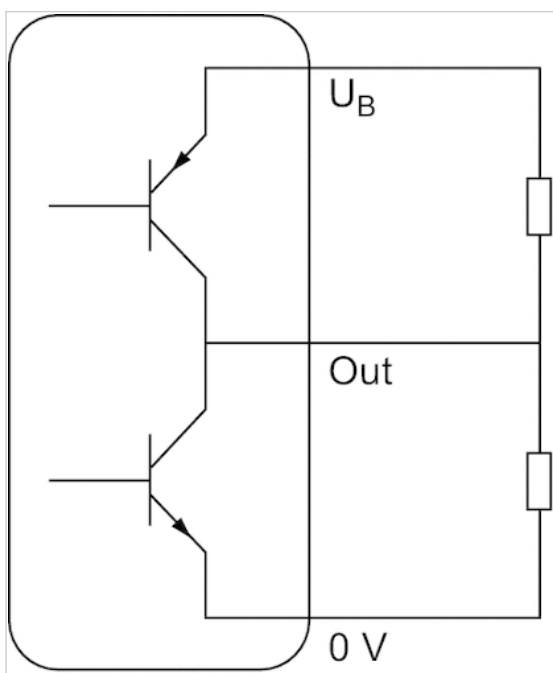

Hysteresis function: switching and resetting behavior dependent on pressure p and time t In case

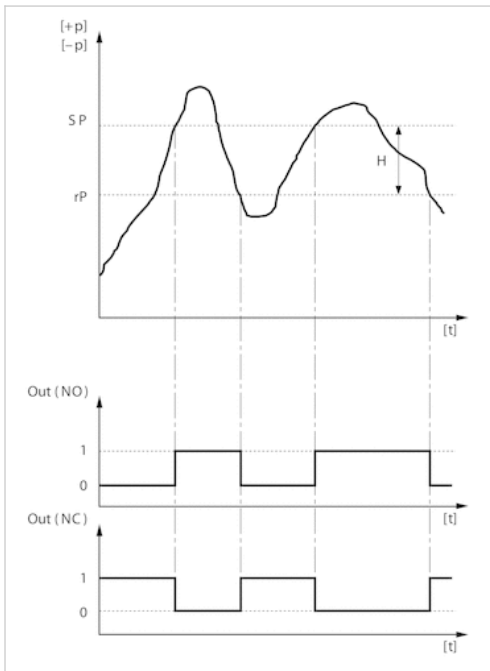

H: Hysteresis
 SP = switching point RP = resetting point
 Out (NC): switch output, break contact Out (NO): switch output, make contact

Hysteresis function: switching and resetting behavior dependent on pressure p and time t In case

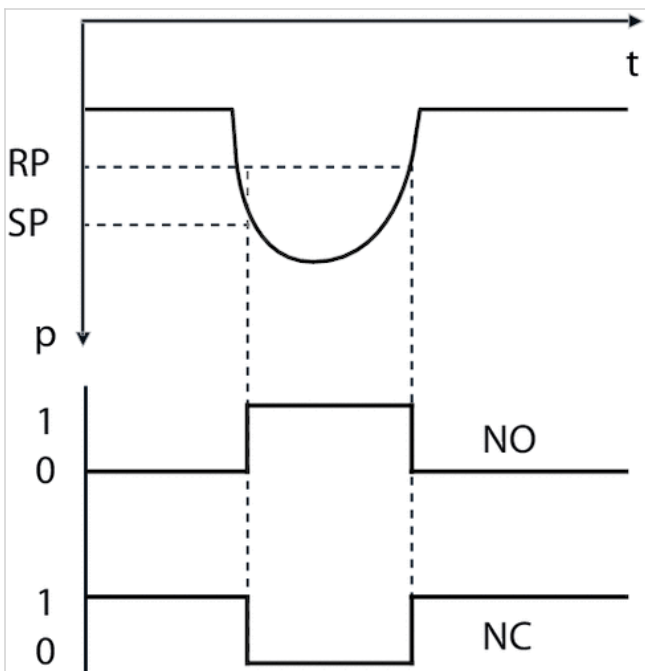

Delayed hysteresis function: switching and resetting behavior depending on pressure p and time

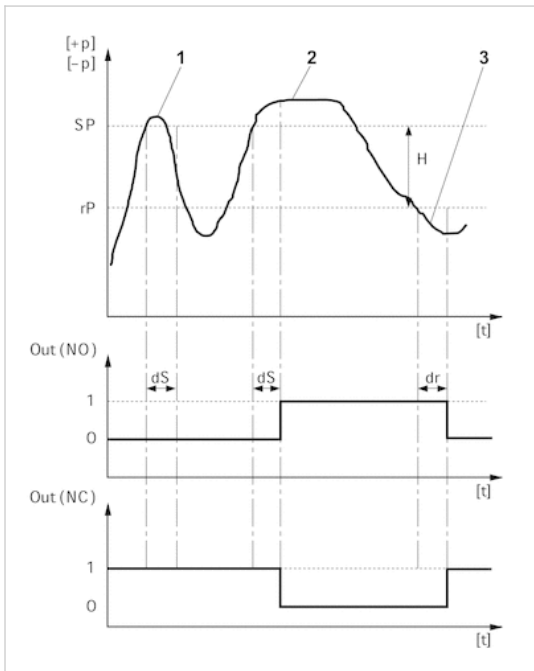

H: Hysteresis

SP = switching point RP = resetting point

Out (NC): switch output, break contact Out (NO): switch output, make contact

dS: switching delay dR = reset delay

1) period of pressure over the switching point dS : pressure sensor does not switch
 2) Period of pressure over the switching point $> dS$: pressure sensor switches
 3) Period of pressure under the resetting point $> dR$: pressure sensor switches

Window function: switching and resetting behavior depending on pressure p and time t

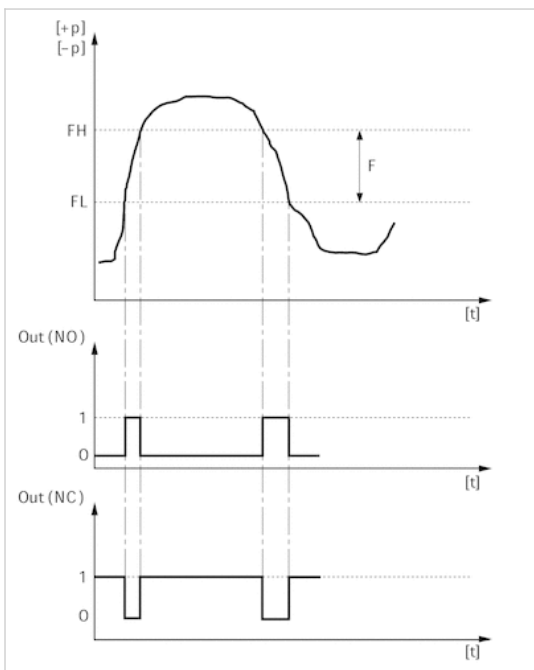

FH: pressure band, upper value

FL: pressure band, lower value

Out (NC): switch output, break contact Out (NO): switch output, make contact

circuit diagram

Block diagram 1x PNP and 1x analog

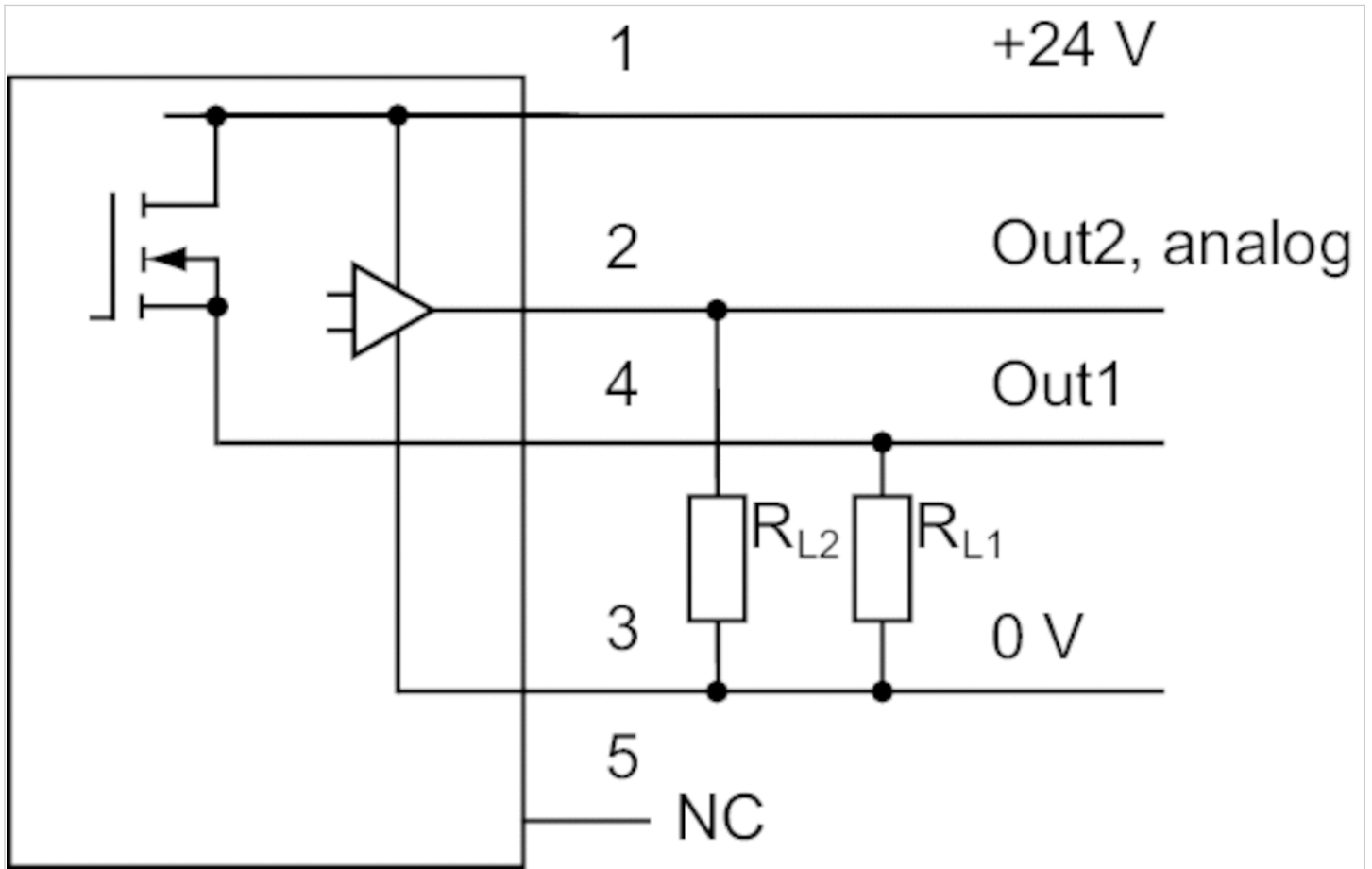

RL = storable position

Block diagram 1x NPN and 1x analog

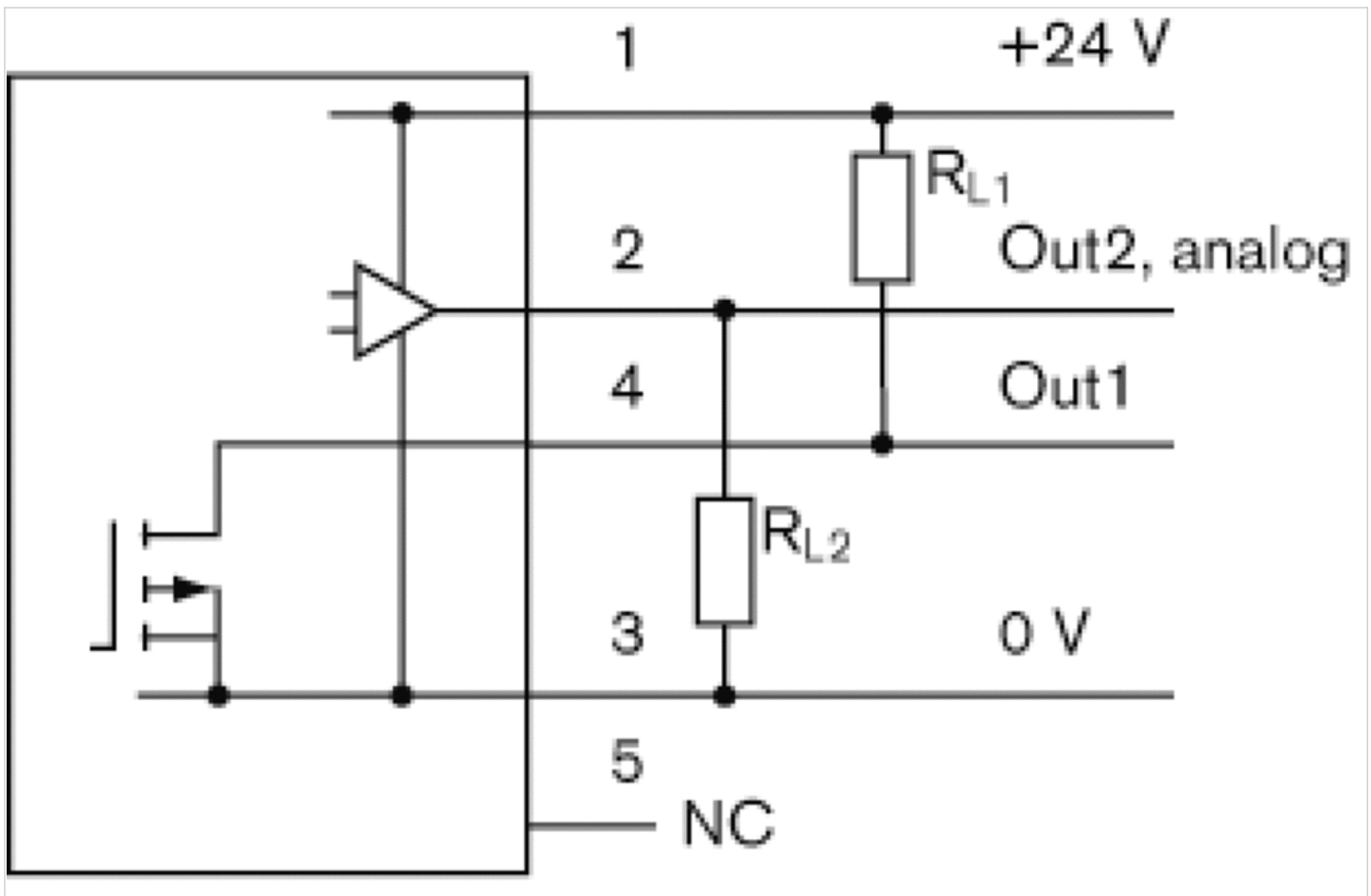

RL = storable position

Pin assignments

Pin assignments M12x1

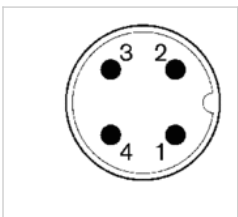

- Pin 1: operational voltage + UB
- Pin 2: switch output Out2, analog: A or V, digital: PNP, NPN, push-pull
- Pin 3: 0 V
- Pin 4: switch output Out1, digital: PNP, NPN, push-pull