

Linear actuator

Matrix 6

Benefits

- Silent operation
- Full system with integrated control unit and accessories
- Compact and aesthetic
- Back-up nut as standard



Suitable control units and accessories

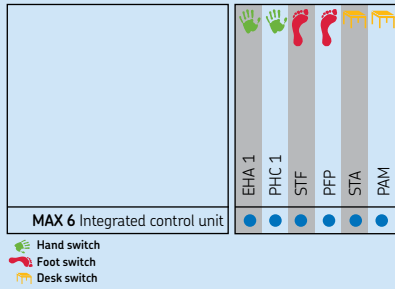

Connecting diagram

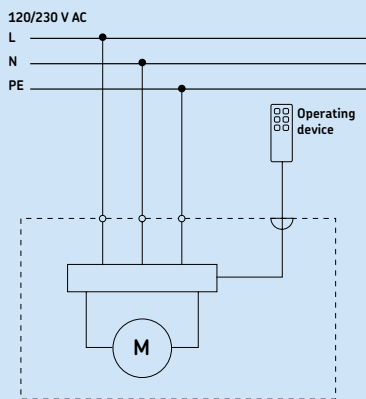

Dimensional drawing

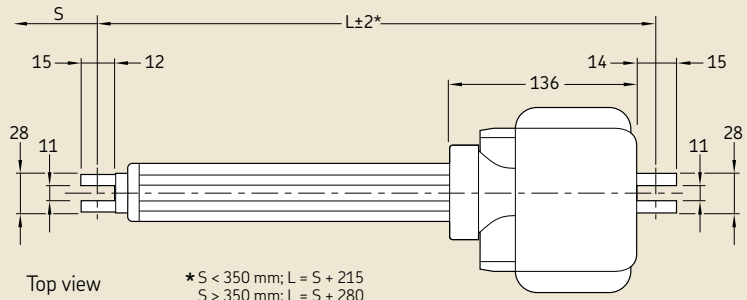
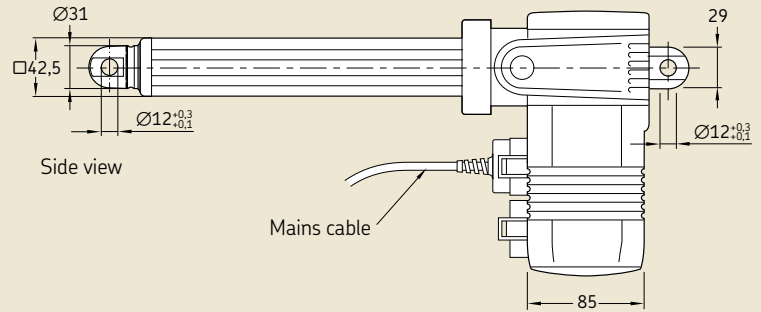

Rear attachment position
Standard 0°

Turned 90°

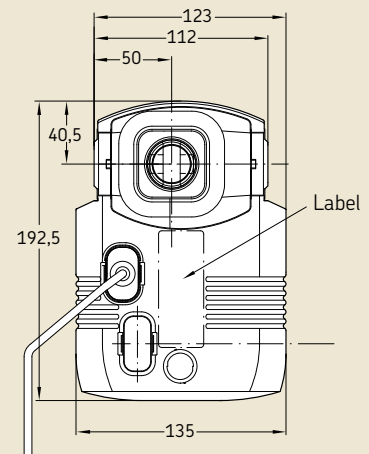
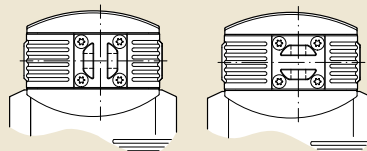

Technical data

| | Unit | MAX 6..A.. | MAX 6..B.. | MAX 6..C.. |
|------------------------------|-----------|---------------------------|---------------------------|---------------------------|
| Rated push load | N | 8 000 | 4 000 | 3 000 |
| Rated pull load | N | 6 000 ¹⁾ | 4 000 | 3 000 |
| Speed (full load to no load) | mm/s | 6 to 7,5 | 8 to 10 | 13 to 18 |
| Stroke | mm | 50 to 700 | 50 to 700 | 50 to 700 |
| Retracted length | mm | S + 215/280 ²⁾ | S + 215/280 ²⁾ | S + 215/280 ²⁾ |
| Voltage | VAC | 120 or 230 | 120 or 230 | 120 or 230 |
| Power consumption | 120 VAC W | 150 | 150 | 150 |
| | 230 VAC W | 145 | 145 | 145 |
| Current consumption | 120 VAC A | 2,0 | 2,0 | 2,0 |
| | 230 VAC A | 1,0 | 1,0 | 1,0 |
| Duty cycle | % | 10 (1/9) | 10 (1/9) | 10 (1/9) |
| Ambient temperature | °C | 0 to +40 | 0 to +40 | 0 to +40 |
| Type of protection | IP | 66S | 66S | 66S |
| Weight (at 200 mm stroke) | kg | 4,8 | 4,5 | 4,2 |
| Color | - | Grey | Grey | Grey |

¹⁾ Max load for medical application is 5 000 N

²⁾ S < 350 mm; L = S + 215
S > 350 mm; L = S + 280

Performance diagrams

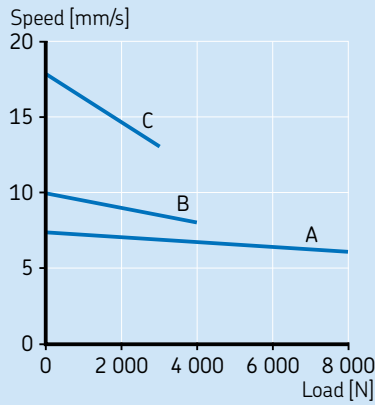

Speed-load diagram

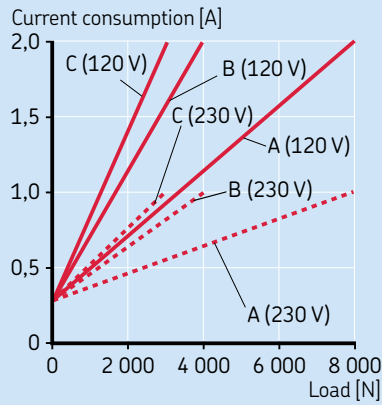

Current-load diagram

Safety factor load conditions

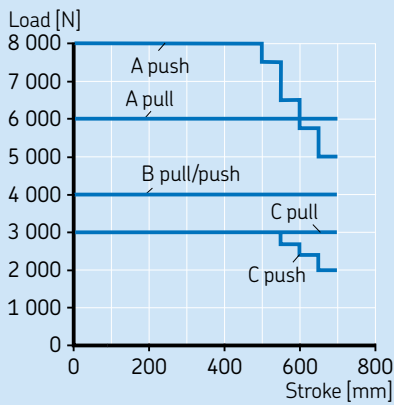

Push load reduction static
Safety factor S=1

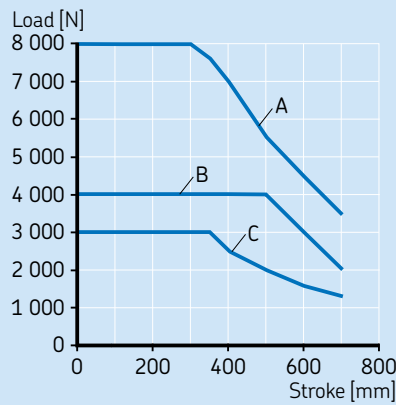

Push load reduction static
Safety factor S=2

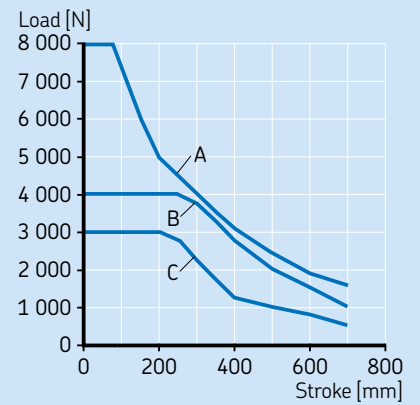

Push load reduction static
Safety factor S=4 (EN60601)

Accessories

| | Plug | Country | Designation | Order number |
|-----------------------------------|------------------|---------|-----------------|--------------|
| Straight cable 3,5 m | Schuko | DE | ZKA-140306-3500 | M/0121723 |
| Straight cable 3,5 m | SEV | CH | ZKA-140316-3500 | M/0121737 |
| Straight cable 3,5 m | UL | USA | ZKA-140355-3500 | M/0121724 |
| Straight cable 3,5 m | Hospital grade | USA | ZKA-140360-3500 | M/0121732 |
| Straight cable 3,5 m | British standard | UK | ZKA-140350-3500 | M/0121743 |
| Coiled cable 1,2 m / 2,2 m | Schuko | DE | ZKA-140342-1500 | M/0121728 |
| Coiled cable 1,2 m / 2,2 m | SEV | CH | ZKA-140378-1200 | M/0121738 |
| Straight polyurethane cable 3,5 m | SEV | CH | ZKA-140422-3500 | M/0121739 |
| Straight polyurethane cable 3,5 m | Schuko | DE | ZKA-140426-3500 | M/0121740 |
| Strain relief for mains cable | | | ZUB-952253 | M/0102848 |
| Tool for plugs (Jack/D-Sub/Mains) | | | ZWS-140375 | M/0125322 |

