

A

B

C

D

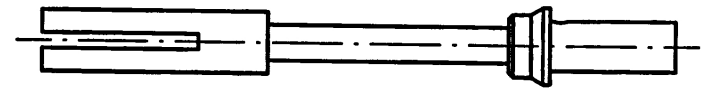
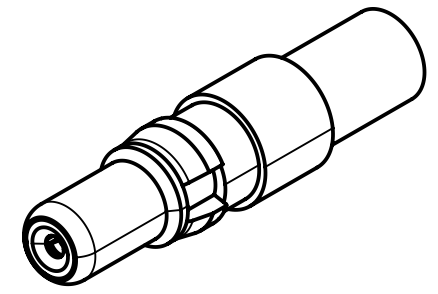
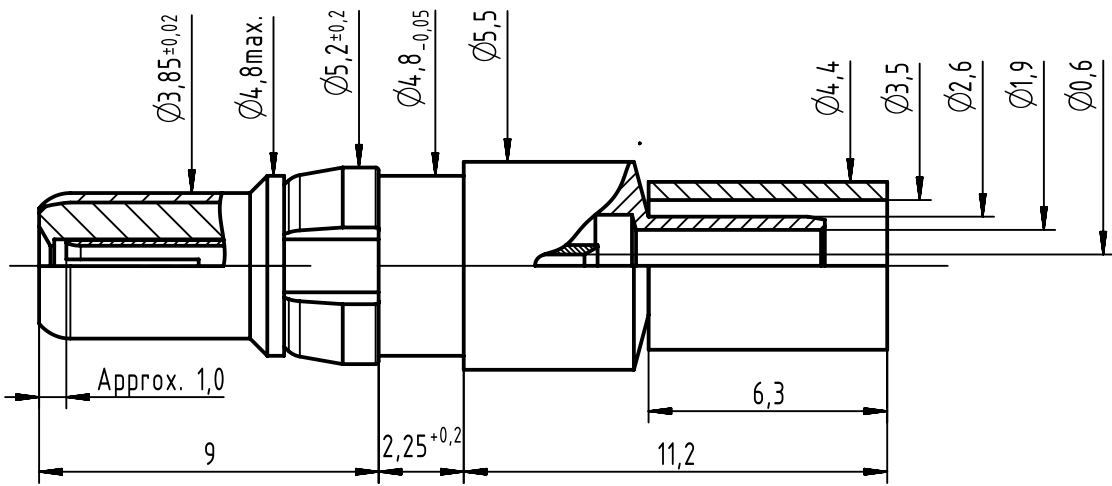

Harnessing dimensions for cables RG179 double shielded

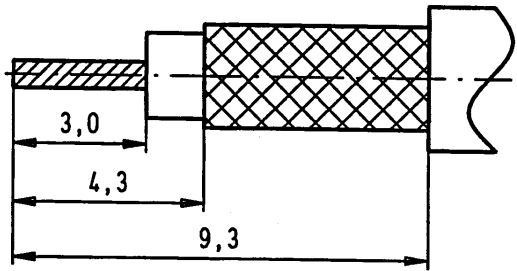

Crimping tool for outer conductor:
hand tool: 09 99 000 0503
die: 09 99 000 0519 cavity B

Crimping tool for outer conductor:
hand tool: 09 99 000 0501
die: 09 99 000 0507
with cables: AWG 24, AWG 26, AWG 28, AWG 30
tool selections: 5 5 4 3

				All Dimensions in mm Original Size DIN A4		Scale 5:1	Free size tol.		Ref. Sub.		
				All rights reserved Department EC PD - CN		Created by ZHUANGJ	Inspected by LUOK	Standardisation HOFFMANN	Date 2016-05-09	State Final Release	
0969 282 7233		Mating area	0,2 µm Au	0,2 µm Au	Title D-Sub mixed male crimp contact 75ohm					Doc-Key / ECM-Nr. 100223308/UGD/001/B 500000104.193	
0969 282 5233		Termination area	5 µm Sn	0,2 µm Au							
0969 282 5233		Mating area	0,8 µm Au	1,3 µm Au	Type TB					Rev. B	
0969 282 5233		Termination area	0,2 µm Au	1,3 µm Au						Number 0969282X233	
Part number		conductor plating	Outer	Inner	HARTING Electronics GmbH D-32339 Espelkamp						