

# SSA-EB Series Emergency Stop Push Button

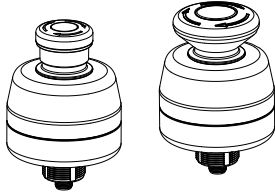

## Datasheet

### Non-illuminated 30 mm Mount Electro-mechanical Push Buttons



- Rugged design; easy installation with no assembly or individual wiring required
- Push-to-stop, twist-to-release, or pull-to-release operation per EN 60947-5-5
- Models with the washdown cover are push-to-stop and pull-to-release operation per EN 60947-5-5
- Latching design complies with ISO 13850; direct (positive) opening operation per EN 60947-5-1
- Compliant with ANSI B11.19, ANSI NFPA79, and IEC/EN 60204-1 Emergency Stop requirements
- "Safe Break Action" ensures N.C. contacts will open if the contact block is separated from the actuator
- 4-, 5-, or 8-pin M12/Euro-style quick disconnect
- Models designed to interface with Safety BUS nodes/gateways
- "Emergency Stop" legend included
- U.S. Patent No. Des. 700,149
- FDA-grade silicone cover withstands high pressure, high temperature washdown, and increases the product rating to IEC IP69; the cover is ECOLAB® certified to withstand aggressive cleaning procedures with chemicals used in the food processing industry

Models SSA-EB... series are "mushroom-style" electro-mechanical emergency stop push buttons. When the button is armed, the switch's safety contacts (N.C.) are closed and its monitoring contacts (N.O.), if present, are open. When the button is pushed, the switch's safety contacts open, and the monitoring contacts close. The contacts remain in this condition until the push button is manually rearmed by pulling or twisting clockwise the red push button actuator.

The SSA-EB1P.. and SSA-EB2P..ECQ.. series has a 30 mm mounting base similar to Banner's OTB, VTB, and STB Optical Touch Buttons for ease of mounting without requiring an additional enclosure.

## Models

Model	Push Button	E-Stop Contacts	Connection
SSA-EB1P-02ECQ4	Standard 40 mm	2 N.C.	Integral 4-pin M12/Euro-style quick disconnect
SSA-EB1P-11ECQ4		1 N.C. / 1 N.O.	
SSA-EB1P-02ECQ5A	Standard 40 mm	2 N.C.	Safety BUS node compatible <sup>1</sup>
SSA-EB2P-02ECQ5A	Large 60 mm		Integral 5-pin M12/Euro-style quick disconnect CH1 = pins 1 & 2, CH2 = pins 4 & 5
SSA-EB1P-02ECQ5B	Standard 40 mm	2 N.C.	Safety BUS node compatible <sup>2</sup>
SSA-EB2P-02ECQ5B	Large 60 mm		Integral 5-pin M12/Euro-style quick disconnect CH1 = pins 1 & 4, CH2 = pins 2 & 5
SSA-EB1P-22ECQ8	Standard 40 mm	2 N.C. / 2 N.O.	Integral 8-pin M12/Euro-style quick disconnect
SSA-EB2P-04ECQ8	Large 60 mm	4 N.C.	

Washdown Cover Model	For Push Button Models	Description
SSA-EB1P-ECWC	Standard 40 mm	FDA-grade silicone cover

To order a model with the washdown cover installed, add "-WC" to the model number. For example, **SSA-EB1P-02ECQ4-WC**.

<sup>1</sup> Compatible with AllenBradley ArmorBlock® 1732DS Safe DeviceNet remote I/O.  
<sup>2</sup> Compatible with Siemens ET 200pro PROFIsafe gateway.



## Important... Read this before proceeding!

---

**The user is responsible for satisfying all local, state, and national laws,** rules, codes, and regulations relating to the use of this product and its application. Banner Engineering Corp. has made every effort to provide complete application, installation, operation, and maintenance instructions. Please contact a Banner Applications Engineer with any questions regarding this product.

**The user is responsible** for making sure that all machine operators, maintenance personnel, electricians, and supervisors are thoroughly familiar with and understand all instructions regarding the installation, maintenance, and use of this product, and with the machinery it controls. The user and any personnel involved with the installation and use of this product must be thoroughly familiar with all applicable standards, some of which are listed within the specifications. Banner Engineering Corp. makes no claim regarding a specific recommendation of any organization, the accuracy or effectiveness of any information provided, or the appropriateness of the provided information for a specific application.



### **WARNING: Not a Safeguarding Device**

**An Emergency Stop Device is not considered a safeguarding device because it requires an overt action by an individual to stop machine motion or hazards.**

A safeguarding device limits or eliminates an individual's exposure to a hazard *without action by the individual or others*. Because an individual must actuate the device for it to function, these devices do not fit the definition of a safeguarding device and cannot be substituted for required safeguarding. Refer to the relevant standards to determine those requirements.

## U.S. Application Standards

ANSI B11.0 Safety of Machinery; General Requirements and Risk Assessment

ANSI B11.19 Performance Criteria for Safeguarding

ANSI NFPA 79 Electrical Standard for Industrial Machinery

## International/European Standards

EN ISO 12100 Safety of Machinery – General Principles for Design – Risk Assessment and Risk Reduction

ISO 13850 (EN 418) Emergency Stop Devices, Functional Aspects – Principles for Design

IEC 62061 Functional Safety of Safety-Related Electrical, Electronic and Programmable Control Systems

EN ISO 13849-1 Safety-Related Parts of Control Systems

IEC/EN 60204-1 Electrical Equipment of Machines Part 1: General Requirements

EN 60947-1 Low Voltage Switchgear – General Rules

EN 60947-5-1 Low Voltage Switchgear – Electromechanical Control Circuit Devices

EN 60947-5-5 Low Voltage Switchgear – Electrical Emergency Stop Device with Mechanical Latching Function

## EU Declaration of Conformity (DoC)

Banner Engineering Corp. herewith declares that the **SSA-EB1.. Emergency Stop Push Button** is in conformity with the provisions of the Machinery Directive (Directive 2006/42/EC), Low Voltage Directive (2014/35/EU) and all essential health and safety requirements have been met.

Representative in EU: Peter Mertens, Managing Director Banner Engineering Europe. Address: Park Lane, Culliganlaan 2F, bus 3,1831 Diegem, Belgium.

## Emergency Stop Considerations

---

ANSI NFPA 79, ANSI B11.19, IEC/EN 60204-1, and ISO 13850 specify emergency stop requirements, including the following:

- Emergency-stop push buttons shall be located at each operator control station and at other operating stations where emergency shutdown is required.
- Stop and emergency-stop push buttons shall be continuously operable and readily accessible from all control and operating stations where located. Do not mute or bypass E-stop buttons.
- Actuators of emergency-stop devices shall be colored red. The background immediately around the device actuator shall be colored yellow (where possible). The actuator of a push-button-operated device shall be of the palm or mushroom-head type.
- The emergency-stop actuator shall be a self-latching type.



### **WARNING: Emergency Stop Functions**

**Do not mute or bypass any Emergency Stop device.** ANSI B11.19, ANSI NFPA79 and IEC/EN 60204-1 require that **the Emergency Stop function remain active at all times.**



**WARNING: Multiple Switching Devices**

Whenever two or more devices are connected to the same safety module (controller):

- **Contacts of the corresponding pole of each switch must be connected together in series. *Never connect the contacts of multiple switches in parallel.*** Such a parallel connection defeats the switch contact monitoring ability of the Module and creates an unsafe condition which could result in serious injury or death.
- **Each device must be individually actuated (engaged), then released (or re-armed) and the safety module reset.** This allows the module to check each switch and its wiring to detect faults.

This check must be performed during the prescribed checkouts. **Failure to test each device individually in this manner could result in undetected faults and create an unsafe condition which could result in serious injury or death.**

## Installation and Maintenance

The device must not be affected by environmental conditions. **Install the device so that operation is not impeded, but should be protected against inadvertent operation** (for example, accidental actuation by being bumped or leaned against). Do not operate the switch using a tool. Do not expose the switch to excessive shocks and vibrations, otherwise the switch may be deformed or damaged, causing malfunction or operation failure. Hardware includes jam nut, lock washer, lock ring, and seal washer. The lock ring may be used to prevent switch rotation if a 5mm hole keyway is provided.

Electrical installation must be made by qualified personnel<sup>3</sup> and must comply with NEC (National Electrical Code), ANSI/NFPA 79 or IEC/EN 60204-1, and all applicable local standards. It is not possible to give exact wiring instructions for a device that interfaces to a multitude of machine control configurations. The following is general in nature; it is recommended to perform a risk assessment to ensure appropriate application, interfacing/hookup, and risk reduction (see ISO 12100 or ANSI B11.0).



**WARNING: Shock Hazard and Hazardous Energy**

**Always disconnect power from the safety system (for example, device, module, interfacing, etc.) and the machine being controlled before making any connections or replacing any component.**

Electrical installation and wiring must be made by Qualified Personnel<sup>4</sup> and must comply with the relevant electrical standards and wiring codes, such as the NEC (National Electrical Code), ANSI NFPA79, or IEC/EN 60204-1, and all applicable local standards and codes.

**Lockout/tagout procedures may be required.** Refer to OSHA 29CFR1910.147, ANSI Z244-1, ISO 14118, or the appropriate standard for controlling hazardous energy.

Table 1: SSA-EB1P-02ECQ4 (2 N.C.) and SSA-EB1P-11ECQ4 (1 N.C./1 N.O.)

Pin	Color	Function	Contacts		Pinout
			02ECQ4	11ECQ4	
1	Brown	CH1b	N.C.	N.C.	
2	White	CH2a	N.C.	N.O.	
3	Blue	Ch2b	N.C.	N.O.	
4	Black	CH1a	N.C.	N.C.	
5	n.a.	n.a.			

<sup>3</sup> A Qualified Person possesses a recognized degree or certificate or has extensive knowledge, training, and experience to solve problems relating to the emergency stop installation.

<sup>4</sup> A person who, by possession of a recognized degree or certificate of professional training, or who, by extensive knowledge, training and experience, has successfully demonstrated the ability to solve problems relating to the subject matter and work.

Table 2: SSA-EB1(2)P-02ECQ5A (2 N.C.)<sup>5</sup> and SSA-EB1(2)P-02ECQ5B (2 N.C.)<sup>6</sup>

Pin	Color	02ECQ5A		02ECQ5B		Pinout
		Function	Contacts	Function	Contacts	
1	Brown	CH1a	N.C.	CH1b	N.C.	
2	White	CH1b	N.C.	CH2a	N.C.	
3	Blue	n.c.		n.c.		
4	Black	CH2a	N.C.	CH1a	N.C.	
5	Gray	CH2b	N.C.	CH2b	N.C.	

Table 3: SSA-EB2P-04ECQ8 (4 N.C.) and SSA-EB1P-22ECQ8 (2 N.C./2 N.O.)

Pin	Color	SSA-EB2P-04ECQ8		SSA-EB1P-22ECQ8		Pinout
		Function	Contacts	Function	Contacts	
1	White	CH3a	N.C.	AUX1a	N.O.	
2	Brown	CH4a	N.C.	AUX2a	N.O.	
3	Green	CH3b	N.C.	AUX1b	N.O.	
4	Yellow	CH2a	N.C.	CH2a	N.C.	
5	Gray	CH2b	N.C.	CH2b	N.C.	
6	Pink	CH1a	N.C.	CH1a	N.C.	
7	Blue	CH4b	N.C.	AUX2b	N.O.	
8	Red	CH1b	N.C.	CH1b	N.C.	

## Checkout

At machine set up, a *Designated Person*<sup>7</sup> should test each emergency stop push button for proper machine shutdown response. A *Designated Person* should check the emergency stop buttons for proper operation, physical damage, button looseness, and excessive environmental contamination. This should take place on a periodic schedule determined by the user, based on the severity of the operating environment and the frequency of switch actuations. Adjust, repair, or replace components as needed. If inspection reveals contamination on the switch, thoroughly clean the switch and eliminate the cause of the contamination. Replace the switch and/or appropriate components when any parts or assemblies are damaged, broken, deformed, or badly worn; or if the electrical/mechanical specifications (for the environment and operating conditions) have been exceeded. **Always test the control system for proper functioning** under machine control conditions after performing maintenance, replacing the emergency stop device, or replacing any component of the device.

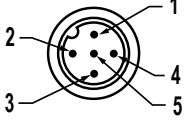
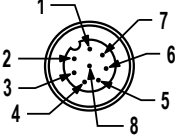
## Installing the Silicone Cover

To properly install the FDA-grade silicone cover and achieve an IEC IP69 rating, follow these instructions.

1. Turn the cover inside-out, except for the top portion the button fits into.
2. Place the cover on top of the emergency stop unit.
3. Roll the cover onto the e-stop unit.
4. Continue rolling the cover down, around the base of the e-stop unit, until the entire unit is covered.
5. Mount the e-stop and cover assembly to a bracket wide enough to cover the base of the assembly. The cover should be clamped firmly between the e-stop button and the bracket.



**Note:** This cover is suitable for applications with pull-to-release resetting methods.



<sup>5</sup> Compatible with AllenBradley ArmorBlock® 1732DS Safe DeviceNet remote I/O

<sup>6</sup> Compatible with Siemens ET 200pro PROFIsafe gateway

<sup>7</sup> A *Designated Person* is identified in writing by the employer as being appropriately trained to perform a specified checkout procedure. A *Qualified Person* possesses a recognized degree or certificate or has extensive knowledge, training, and experience to solve problems relating to the emergency stop installation.

## Specifications

### Housing/Button

Polycarbonate / Polyamide  
Threaded base has M30 by 1.5 external threads; Maximum Tightening Torque: 4.5 N·m (40 in·lbf)

### Operating Conditions

**Temperature:** -25 °C to +55 °C (-13 °F to +131 °F)  
**Humidity:** 45% to 85% RH (no condensation)

### Environmental Rating

IEC IP65 (IEC 60529), and UL Type 4X Indoor, 13  
IEC IP67, IEC IP69 (IEC 60529), and UL Type 4X, 13 (with SSA-EB1P-ECWC cover installed)

### Insulation Resistance

100 MΩ minimum (500 V dc megger)

### Impulse Withstand Voltage

2.5 kV

### Contact Material/Bounce<sup>8</sup>

Gold plated silver / 20 ms

### Required Overcurrent Protection



**WARNING:** Electrical connections must be made by qualified personnel in accordance with local and national electrical codes and regulations.

Overcurrent protection is required to be provided by end product application per the supplied table.  
Overcurrent protection may be provided with external fusing or via Current Limiting, Class 2 Power Supply.  
Supply wiring leads < 24 AWG shall not be spliced.  
For additional product support, go to [www.bannerengineering.com](http://www.bannerengineering.com).

Supply Wiring (AWG)	Required Overcurrent Protection (Amps)
20	5.0
22	3.0
24	2.0
26	1.0
28	0.8
30	0.5

### Pollution Degree

3

### Output Configuration

See [Installation and Maintenance](#) on page 3

### Overvoltage Category

II

### Electrical Life

100,000 operations minimum, 250,000 operations minimum at 24 V AC/DC, 100 mA

### Mechanical Life

250,000 operations

### Shock Resistance

**Operating extremes:** 150 m/s<sup>2</sup> (15G)

### Vibration Resistance

**Operating extremes:** 10 Hz to 500 Hz, amplitude 0.35 mm acceleration 50 m/s<sup>2</sup>

### Electrical Rating

**Minimum load:** 1 mA at 5 V ac/dc

**SSA-EB1(2)xx-.Q4 and -.Q5:** 3 A at 250 V maximum

**SSA-EB1(2)xx-.Q8:** 2 A at 60 V ac/75 V dc maximum

**UL Applications:** 1.5 A at 250 V ac, 1 A at 30 V dc (pilot duty)

**CE Applications:** AC-15: 1.5 A at 250 V ac, DC-13: 1 A at 30 V dc

### Rated Insulation Voltage (Ui)

250 V

### Rated Current (Ith)

3A

### B10d

100,000 (based on ISO13849-1(2006))

### Design and Application Standards

Compliant with EN 60497-1 / -5-1, ISO 13850, ANSI B11.19 , ANSI NFPA79, IEC/EN 60204-1

### Date code format (U.S. Standard Format)

YYWWX: 2-digit year, 2-digit week, "X" internal code

### Certifications



### Rated Operating Current and Voltage (Ue)

Safety Contact (N.C.)		30 V	125 V	250 V
AC 50/60 Hz	Resistive Load (AC-12)	-	-	3 A
	Inductive Load (AC-15)	-	3 A	1.5 A
DC	Resistive Load (DC-12)	2 A	0.4 A	0.2 A
	Inductive Load (DC-13)	1 A	0.22 A	0.1 A

Monitor Contacts (N.O.)		30 V	125 V	250 V
AC 50/60 Hz	Resistive Load (AC-12)	-	1.2 A	0.6 A
	Inductive Load (AC-14)	-	0.6 A	0.3 A
DC	Resistive Load (DC-12)	2 A	0.4 A	0.2 A
	Inductive Load (DC-13)	1 A	0.22 A	0.1 A

The operating current is classified according to EN 60947-5-1 making and breaking capacities and are measured at resistive/inductive load types specified in EN 60947-5-1. See "Electrical Rating" above for specific model and UL/CE maximum ratings.

<sup>8</sup> When the button is reset, the normally closed contacts will chatter. When pressing the button, the normally open contacts will chatter. When designing a control circuit, take the contact chatter time into consideration. Do not expose the switch to external shocks, otherwise the contacts will bounce.

## Dimensions

All measurements are listed in millimeters [inches], unless noted otherwise.

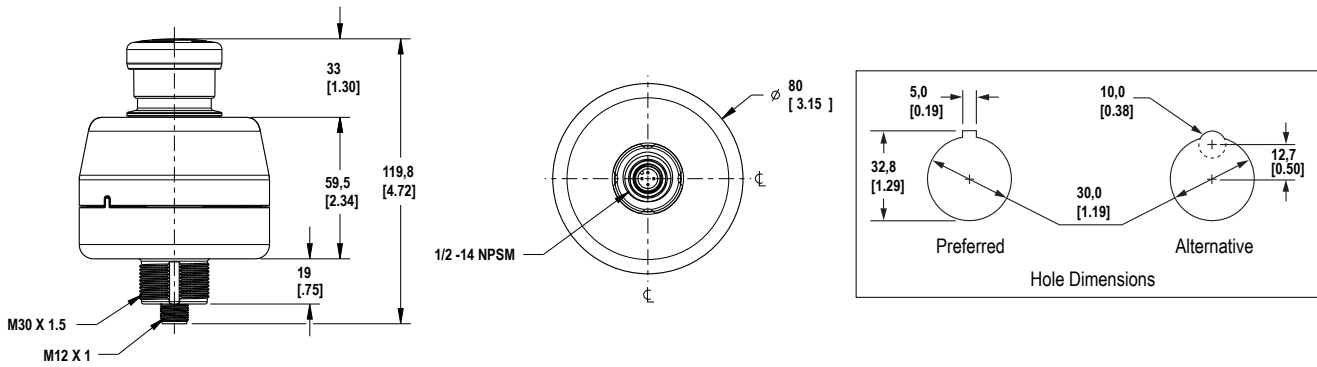

Figure 1. Standard 40 mm Push Button

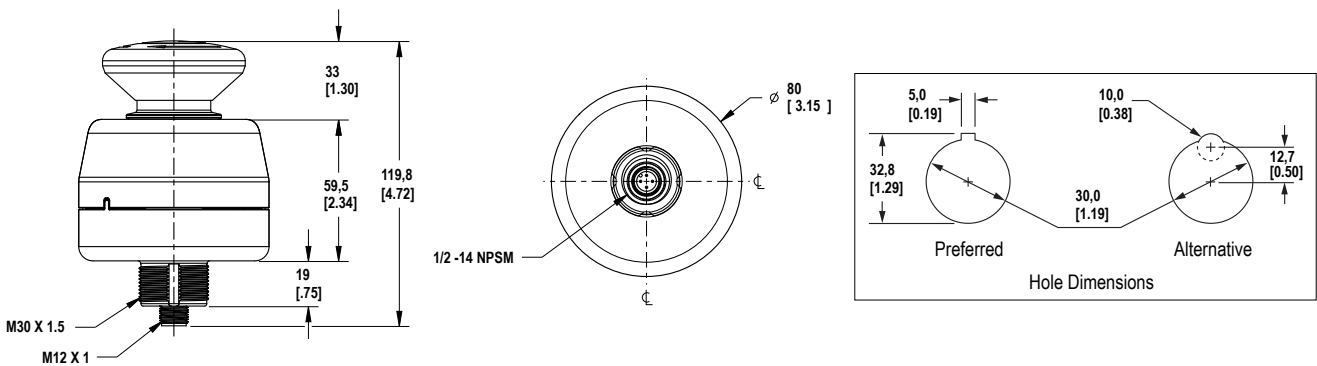
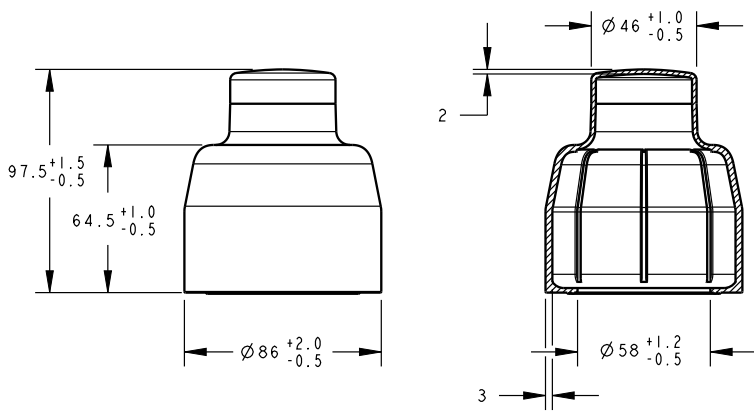

Figure 2. Large 60 mm Push Button

## Dimensions of Washdown Silicone Cover SSA-EB1P-ECWC



## Accessories

### Mounting Brackets

#### SSA-MBK-EEC1

- Single 30 mm hole
- 8 gauge steel, black finish (powder coat)
- Front surface for customer applied labels

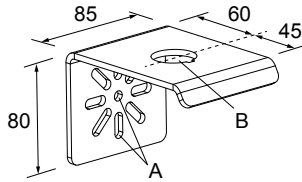

**Hole size:** A =  $\phi$  7 , B =  $\phi$  30

#### SSA-MBK-EEC2

- Two 30 mm holes
- 8 gauge steel, black finish (powder coat)
- Front surface for customer applied labels

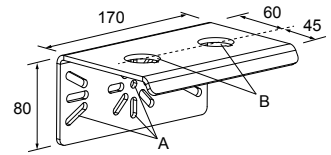

**Hole size:** A =  $\phi$  7 , B =  $\phi$  30

#### SSA-MBK-EEC3

- Three 30 mm holes
- 8 gauge steel, black finish (powder coat)
- Front surface for customer applied labels

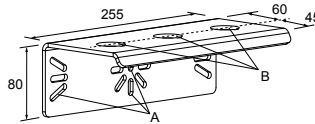

**Hole size:** A =  $\phi$  7 , B =  $\phi$  30

#### SSA-MBK-EEC1-SS

- Single 30 mm hole
- 8 gauge 316 stainless steel
- Front surface for customer applied labels

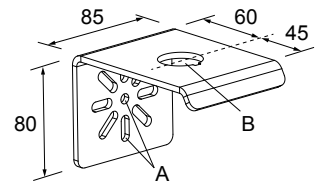

**Hole size:** A =  $\phi$  7 , B =  $\phi$  30

The SSA-MBK-EECx brackets offer:

- Horizontal and vertical (post) mounting
- Interchangeable positions of mounted devices (e.g. OTB/STB/VTB, E-Stop, K50s)

### Cordsets

4-Pin Threaded M12/Euro-Style Cordsets				
Model	Length	Style	Dimensions	Pinout (Female)
MQDC-406	1.83 m (6 ft)	Straight		<p>1 = Brown 2 = White 3 = Blue 4 = Black</p>
MQDC-415	4.57 m (15 ft)			
MQDC-430	9.14 m (30 ft)			
MQDC-450	15.2 m (50 ft)			

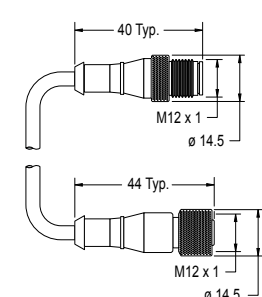
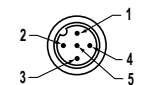
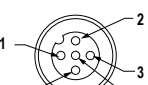
5-Pin Threaded M12/Euro-Style Cordsets—Double Ended				
Model	Length	Style	Dimensions	Pinout
DEE2R-51D	0.31 m (1 ft)	Female Straight/ Male Straight		Male
DEE2R-53D	0.91 m (3 ft)			Female
DEE2R-58D	2.44 m (8 ft)			
DEE2R-515D	4.57 m (15 ft)			
DEE2R-525D	7.62 m (25 ft)			<p>1 = Brown 2 = White 3 = Blue 4 = Black 5 = Green/Yellow</p>
DEE2R-550D	15.2 m (50 ft)			
DEE2R-575D	22.9 m (75 ft)			
DEE2R-5100D	30.5 m (100 ft)			

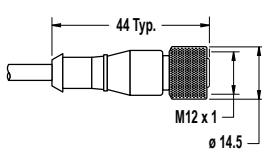
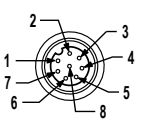
8-Pin Threaded M12/Euro-Style Cordsets with Open-Shield				
Model	Length	Style	Dimensions	Pinout (Female)
MQDC2S-806	1.83 m (6 ft)	Straight		
MQDC2S-815	4.57 m (15 ft)			<p>1 = White      5 = Gray 2 = Brown     6 = Pink 3 = Green     7 = Blue 4 = Yellow     8 = Red</p>
MQDC2S-830	9.14 m (30 ft)			
MQDC2S-850	15.2 m (50 ft)			

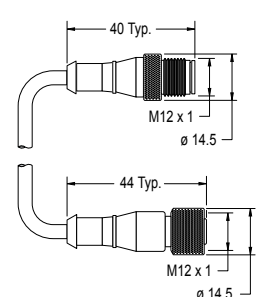
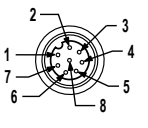
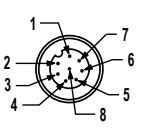
8-Pin Threaded M12/Euro-Style Cordsets—Double Ended				
Model (8-pin/8-pin) <sup>9</sup>	Length	Style	Dimensions	Pinout
DEE2R-81D	0.31 m (1 ft)	Female Straight/ Male Straight		Female
DEE2R-83D	0.91 m (3 ft)			Male
DEE2R-88D	2.44 m (8 ft)			
DEE2R-815D	4.57 m (15 ft)			
DEE2R-825D	7.62 m (25 ft)			<p>1 = White      5 = Gray 2 = Brown     6 = Pink 3 = Green     7 = Blue 4 = Yellow     8 = Red</p>
DEE2R-850D	15.2 m (50 ft)			
DEE2R-875D	22.9 m (75 ft)			
DEE2R-8100D	30.5 m (100 ft)			

See Banner Engineering catalog or [www.bannerengineering.com](http://www.bannerengineering.com) for additional models and complete information.

<sup>9</sup> Standard cordsets are yellow PVC with black overmold. For black PVC and overmold, add suffix "B" to model number (example, DEE2R-81DB)



### Series Hookup Cordset Solution

This interconnection solution allows for quick hookup of a series of string emergency stop buttons. For the models listed below, Branch #1 and Branch #2 are 300 mm (12 in) in length and the length of the trunk is listed below.



**WARNING: Intentional Defeat**

The CSS Series Hookup Cordsets must be installed so that they cannot be easily defeated. Ensure that mounting and routing of the cordsets that are connected to the Trunk, Branch #1, Branch #2, and the E-Stop QD connector does not allow access to the QD connectors or allow improper connection bypassing the function of the Emergency Stop.

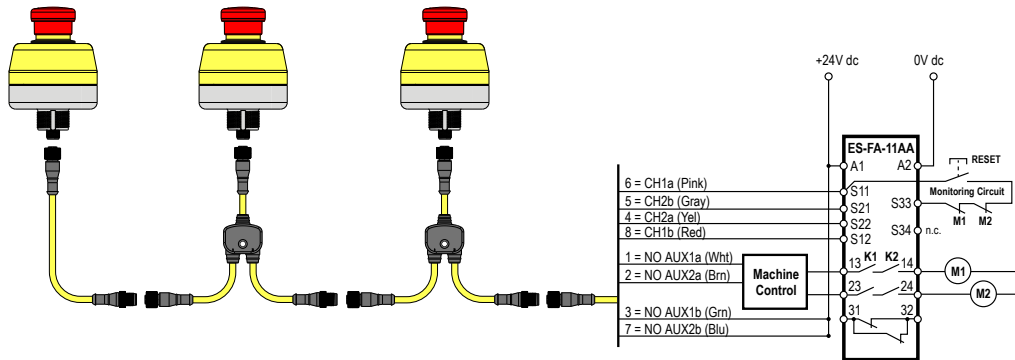

Model	Length	Description
CSS-M12F41M12M41M12F41	0.30 m (1 ft)	4-pin M12 QD splitter cordset for use with SSA-EB1P-02ECQ4
CSS-M12F43M12M41M12F41	0.91 m (3 ft)	
CSS-M12F48M12M41M12F41	2.44 m (8 ft)	

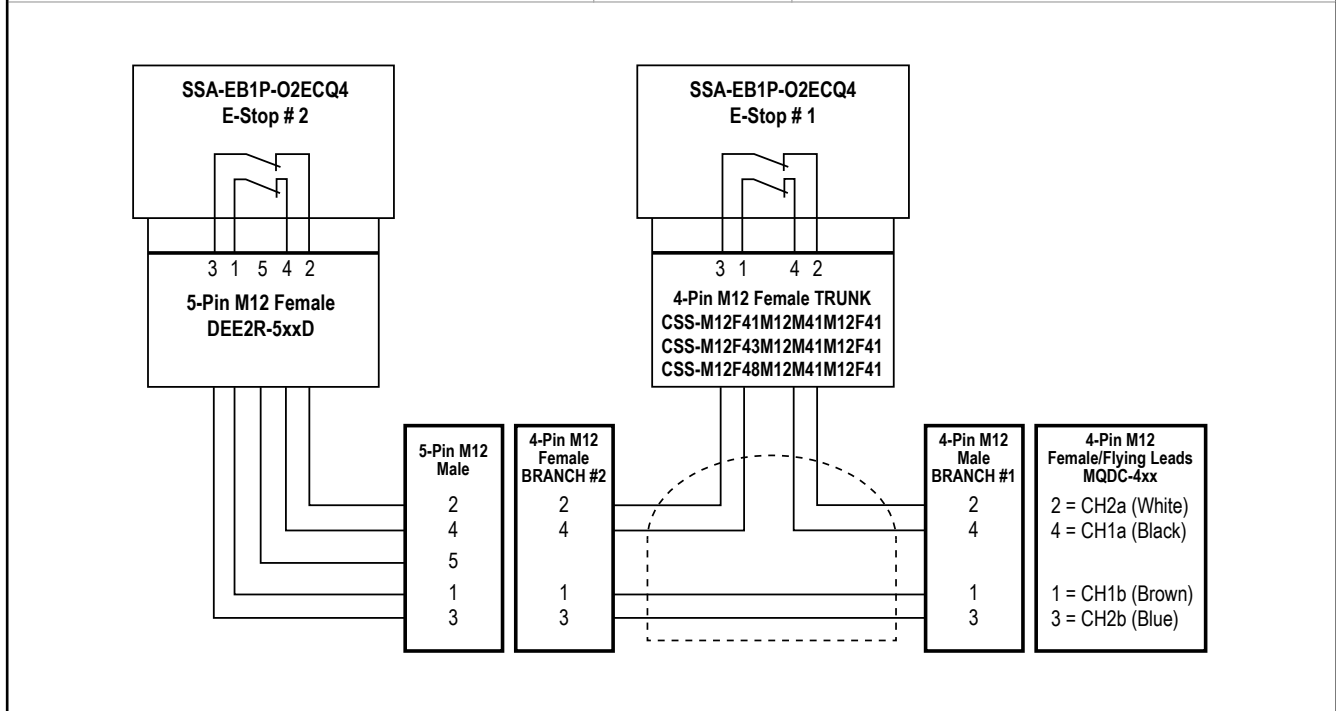

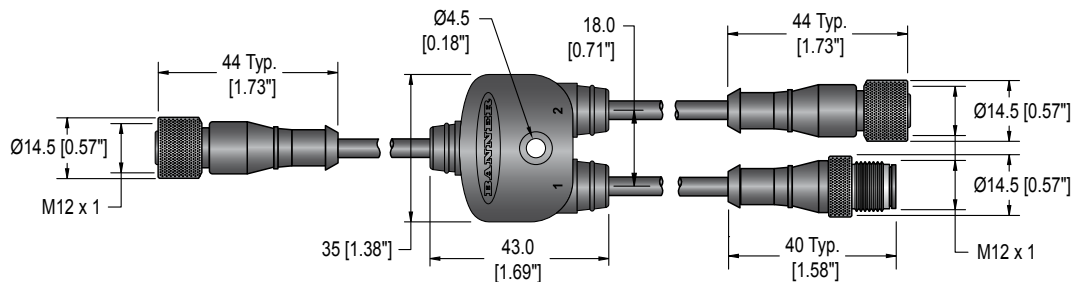
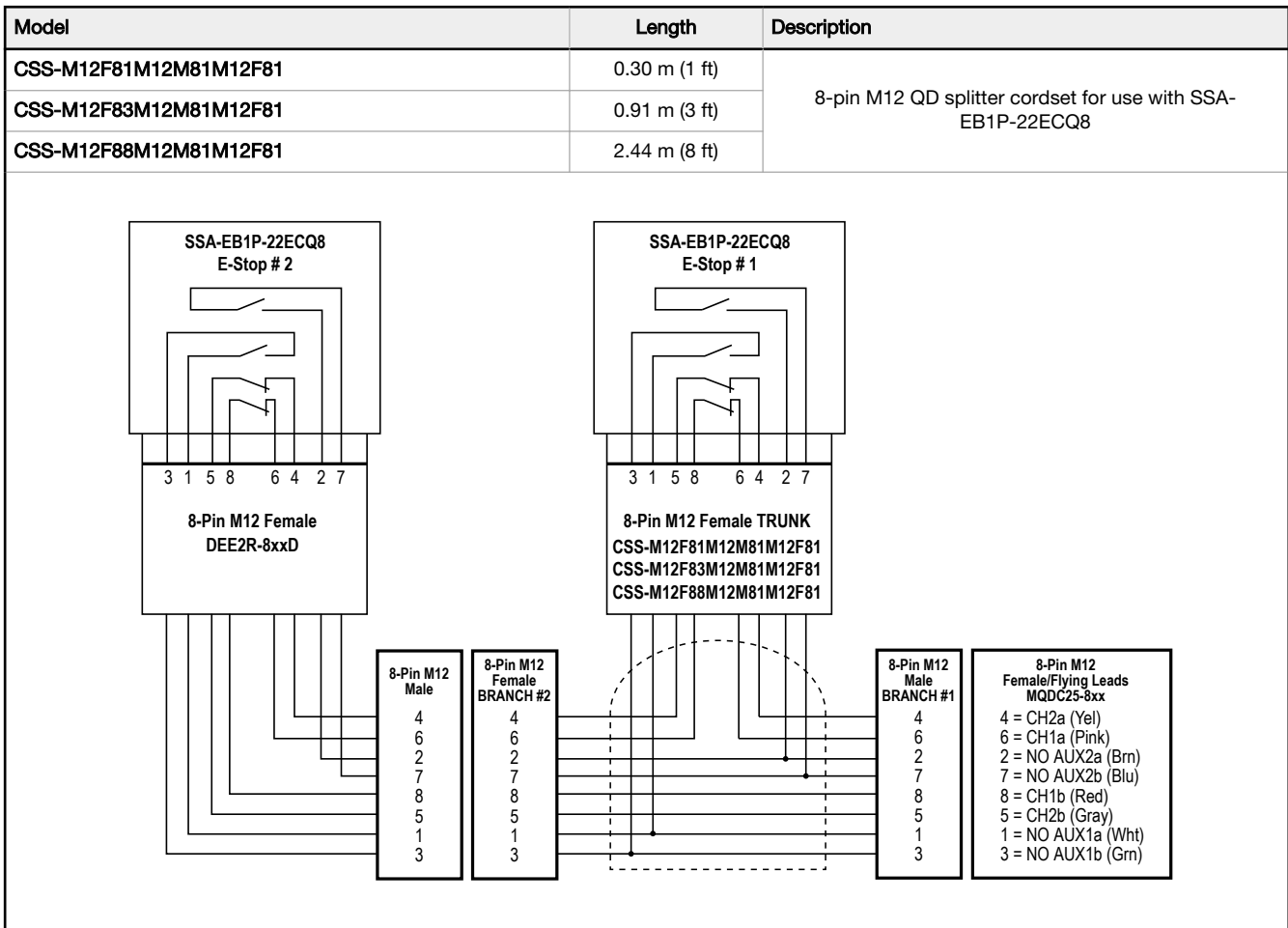

## Banner Engineering Corp. Limited Warranty

Banner Engineering Corp. warrants its products to be free from defects in material and workmanship for one year following the date of shipment. Banner Engineering Corp. will repair or replace, free of charge, any product of its manufacture which, at the time it is returned to the factory, is found to have been defective during the warranty period. This warranty does not cover damage or liability for misuse, abuse, or the improper application or installation of the Banner product.

**THIS LIMITED WARRANTY IS EXCLUSIVE AND IN LIEU OF ALL OTHER WARRANTIES WHETHER EXPRESS OR IMPLIED (INCLUDING, WITHOUT LIMITATION, ANY WARRANTY OF MERCHANTABILITY OR FITNESS FOR A PARTICULAR PURPOSE), AND WHETHER ARISING UNDER COURSE OF PERFORMANCE, COURSE OF DEALING OR TRADE USAGE.**

This Warranty is exclusive and limited to repair or, at the discretion of Banner Engineering Corp., replacement. **IN NO EVENT SHALL BANNER ENGINEERING CORP. BE LIABLE TO BUYER OR ANY OTHER PERSON OR ENTITY FOR ANY EXTRA COSTS, EXPENSES, LOSSES, LOSS OF PROFITS, OR ANY INCIDENTAL, CONSEQUENTIAL OR SPECIAL DAMAGES RESULTING FROM ANY PRODUCT DEFECT OR FROM THE USE OR INABILITY TO USE THE PRODUCT, WHETHER ARISING IN CONTRACT OR WARRANTY, STATUTE, TORT, STRICT LIABILITY, NEGLIGENCE, OR OTHERWISE.**

Banner Engineering Corp. reserves the right to change, modify or improve the design of the product without assuming any obligations or liabilities relating to any product previously manufactured by Banner Engineering Corp. Any misuse, abuse, or improper application or installation of this product or use of the product for personal protection applications when the product is identified as not intended for such purposes will void the product warranty. Any modifications to this product without prior express approval by Banner Engineering Corp will void the product warranties. All specifications published in this document are subject to change; Banner reserves the right to modify product specifications or update documentation at any time. Specifications and product information in English supersede that which is provided in any other language. For the most recent version of any documentation, refer to: [www.bannerengineering.com](http://www.bannerengineering.com).