



more sensors, more solutions

# Muting Module

## Models MMD-TA-11B and MMD-TA-12B

### Instruction Manual

#### Features

- Compact, 67.5 mm DIN-mounted housing with plug-in terminal blocks.
- For use with EZ-SCREEN® Output Signal Switching Device (OSSD) outputs or MINI-SCREEN®, MICRO-SCREEN®, MACHINE-GUARD®, or other safety devices with hard relay contact safety output(s) or +24V dc (PNP) outputs.
- Monitors two or four inputs to automatically suspend the safety function of a safeguarding device.
- Can be used as a dual controller when muting function is not used.
- Safety (protective) Stop Interface (SSI) for connection of supplemental safeguarding devices, E-stops, or other devices.
- Category 2, 3, or 4 hookup per ISO 13849-1/-2.
- Selectable external device monitoring (EDM).
- Selectable Automatic or Monitored Manual Reset provides flexibility for point-of-operation, area, or perimeter guarding.
- Two N.O. safety contacts (model **MMD-TA-11B**) or diverse-redundant solid-state safety outputs (model **MMD-TA-12B**).
- Status LEDs and two-digit Diagnostic Display indicate module status.
- Easy configuration for:
  - Auto/manual reset
  - One-/two-channel EDM
  - One-/two-direction muting
  - Selectable mute enable
  - Monitored/non-monitored mute lamp
  - Selectable backdoor timer
  - Selectable mute on power-up

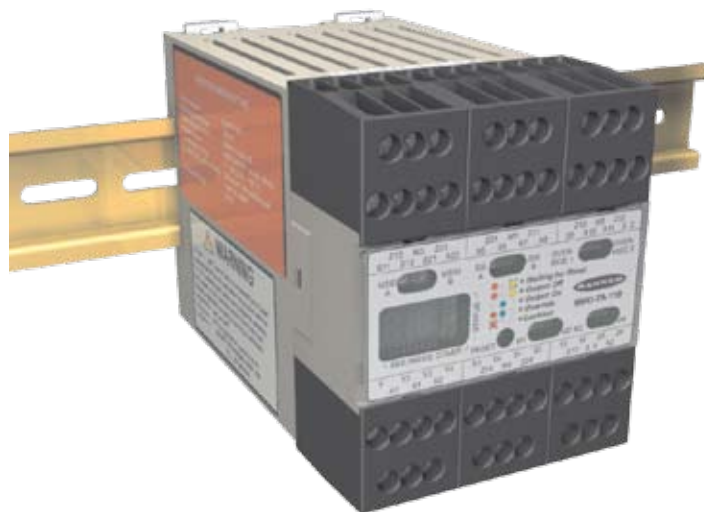

#### Section Contents

Section 1	Introduction	Page 1
Section 2	Components and Specifications	Page 8
Section 3	System Installation	Page 12
Section 4	Operating Instructions	Page 39
Section 5	Troubleshooting and Maintenance	Page 40
Section 6	Checkout Procedures	Page 42
	Appendix	Page 45

## Important ...

### read this before proceeding!

In the United States, the functions that the Banner MMD-TA-11B and MMD-TA-12B Muting Modules are intended to perform are regulated by the Occupational Safety and Health Administration (OSHA). Outside of the United States, these functions are regulated by a variety of agencies, organizations, and governments. Whether or not any particular Muting Module installation meets all applicable requirements depends upon factors that are beyond the control of Banner Engineering Corp. These factors include the details of how the Muting Module is applied, installed, wired, operated, and maintained. **It is the responsibility of the installer and user to apply this Muting Module in full compliance with all applicable regulations and standards.**

The Muting Module can guard against accidents only when it is properly installed and integrated into the machine, properly operated, and properly maintained. Banner Engineering Corp. has attempted to provide complete application, installation, operation, and maintenance instructions. In addition, we suggest that any questions regarding application or use of this Muting Module be directed to the factory applications department at the telephone number or addresses shown on the back cover.

In addition to OSHA regulations, several other organizations provide information about the use of safeguarding devices. Refer to the American National Standards Institute (ANSI), the Robotics Industries Association (RIA), the Association for Manufacturing Technology (AMT), and others. Banner Engineering Corp. makes no claim regarding a specific recommendation of any organization, the accuracy or effectiveness of any information provided, or the appropriateness of the provided information for a specific application.

**See inside back cover for information pertaining to applicable U.S., European, and International standards and where to acquire copies.**

The user has the responsibility to ensure that all local, state, and national laws, rules, codes, and regulations relating to the use of this safeguarding system in any particular application are satisfied. Extreme care is urged to ensure that all legal requirements have been met and that all installation and maintenance instructions contained in this manual are followed.

## Table of Contents

<b>1. Overview</b> .....	<b>page 1</b>
1.1 Introduction .....	page 1
1.2 Operating Status LEDs and Diagnostic Display .....	page 2
1.3 Automatic or Monitored Manual Reset Select .....	page 3
1.4 Lockout Conditions .....	page 3
1.5 Control Reliability: Redundancy and Self-Checking .....	page 3
1.6 Muteable Safety Stop Interface (MSSI) .....	page 4
1.7 Safety Stop Interface (SSI) .....	page 4
1.8 OSSD Outputs .....	page 4
1.9 Auxiliary Output (Aux) .....	page 4
1.10 External Device Monitoring (EDM) .....	page 4
1.11 Mute Inputs (M1-M4) and Mute Devices .....	page 5
1.12 Mute Enable (ME) .....	page 5
1.13 Mute Lamp Output (ML) .....	page 6
1.14 Backdoor Timer .....	page 6
1.15 Mute on Power-Up .....	page 6
1.16 Override .....	page 7
1.17 One-Way/Two-Way Muting .....	page 7
1.18 Designated and Qualified Persons .....	page 7
<b>2. Components and Specifications</b> .....	<b>page 8</b>
2.1 Specifications .....	page 8
2.2 Accessories .....	page 11
2.3 Dimensions .....	page 11
<b>3. System Installation</b> .....	<b>page 12</b>
3.1 Appropriate Application .....	page 12
3.2 Installing the Module .....	page 14
3.3 Muting Module Configuration .....	page 15
3.4 Connection Terminals/Functions .....	page 16
3.5 Installing Input Devices .....	page 17
3.6 Machine Interface – Initial Hookup and Checkout .....	page 30
3.7 Permanent Hookup to the Guarded Machine .....	page 31
3.8 Commissioning Checkout .....	page 34
<b>4. Operating Instructions</b> .....	<b>page 39</b>
4.1 Security Protocol .....	page 39
4.2 Periodic Checkout Requirements .....	page 39
4.3 Normal Operation .....	page 39
<b>5. Troubleshooting and Maintenance</b> .....	<b>page 40</b>
5.1 Troubleshooting Lockout Conditions .....	page 40
5.2 Diagnostic Display .....	page 40
5.3 Effects of Electrical Noise .....	page 40
5.4 Repairs .....	page 40
<b>6. Periodic Checkout Procedures</b> .....	<b>page 42</b>
6.1 Schedule of Checkouts .....	page 42
6.2 Commissioning Checkout .....	page 42
6.3 Daily Checkout .....	page 44
6.4 Semi-Annual Checkout .....	page 44
<b>Appendix</b> .....	
Appendix A, Mute Timing Sequences .....	page 45
Appendix B, Typical Muting Applications .....	page 46
<b>Glossary of Terms</b> .....	<b>page 52</b>

# 1. Overview

## 1.1 Introduction

The Banner MMD-TA-11B / MMD-TA-12B Muting Module (the Module) is an accessory component of a safeguarding system, which may incorporate such primary safeguards as safety light screens, safety interlocked gates/guards, or other presence-sensing safeguarding devices (PSSDs). The Module allows the machine to mute the primary safeguard by monitoring redundant inputs (two or four) and automatically suspend the safeguarding function of a safeguarding device during the non-hazardous portion of the machine cycle.

In this manual, the term “muting” refers to the automatic suspension of the safeguarding function of the primary safety device during a non-hazardous portion of the machine cycle where personnel are not exposed to harm.

The muting function allows material to be manually or automatically fed into or removed from a machine process, without tripping the primary safeguard. The Module accomplishes this by using diverse-redundant microprocessors that monitor the status of inputs and outputs, so that a single fault will cause the Module to issue a stop command to the machine. The Module, like all Banner safety products, is extensively FMEA (Failure Mode and Effects Analysis) tested to establish an extremely high degree of confidence that no internal component will, even if it does fail, cause a failure to danger. This design philosophy aids machine designers to comply with U.S. control reliability and worldwide standards for the highest level of safety.

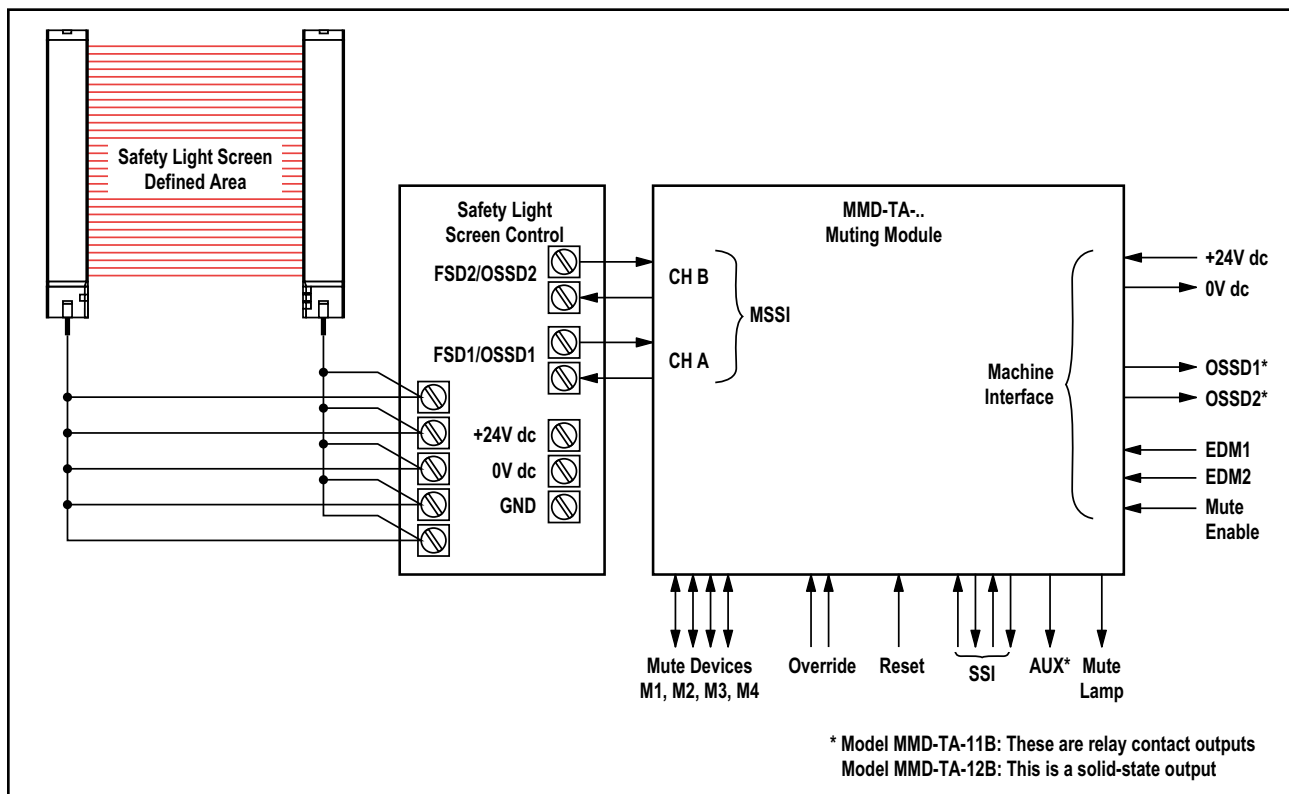

Figure 1-1. Block diagram of a safeguarding system employing the Muting Module and a safety light screen (user-supplied) as a primary safety device

Individual features discussed in the following sections are:

- Operating Status LEDs and Diagnostic Display
- Auto/manual reset
- Lockout conditions
- Control reliability
- Mutable Safety Stop Interface (MSSI)
- Safety Stop Interface (SSI)
- Output Signal Switching Device (OSSD) outputs
- Auxiliary (AUX) output
- External device monitoring (EDM)
- Mute devices and mute inputs (M1-M4)
- Mute enable input (ME)
- Mute lamp output (ML)
- Backdoor timer
- Mute on power-up
- Override
- One-way/two-way muting

### 1.2 Operating Status LEDs and Diagnostic Display

The Module has three Operating Status LEDs (one each red, yellow and green), plus a 2-digit Diagnostic Display, visible through a window in the front cover. The individual LEDs provide constant, ongoing system status information at a glance. The Diagnostic Display provides error codes that correspond to the cause of a fault or configuration error which results in a lockout, and other more detailed conditions. See Sections 4 and 5 for further information.

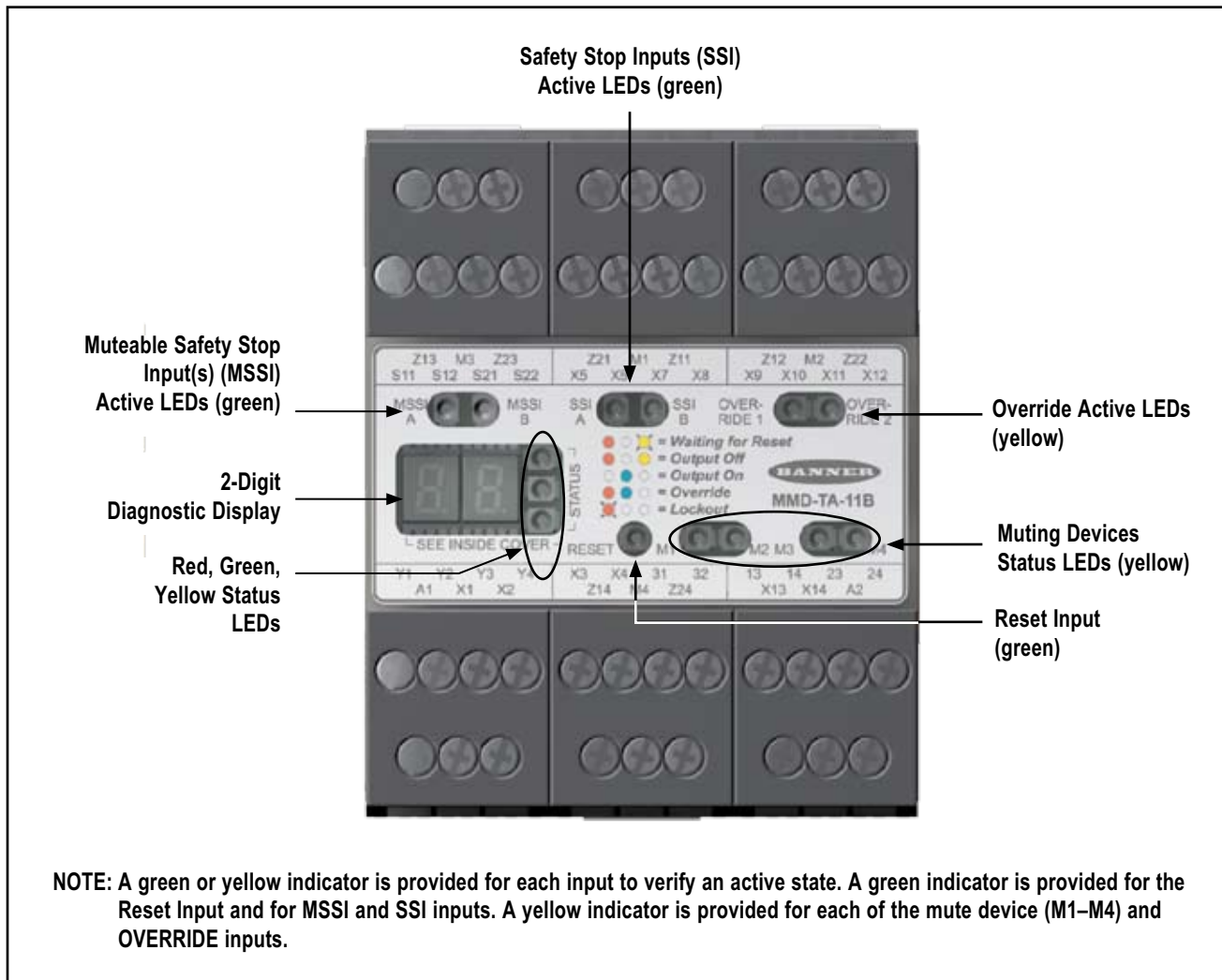

Figure 1-2. Muting Module features

### 1.3 Automatic or Monitored Manual Reset Select

The selectable Automatic or Monitored Manual Reset (X1–X2) provides flexibility for the user who has applications in which the operator is continually sensed, or in applications where the operator can pass through and become clear of the sensing field (see Section 3.1.4, “Pass-Through Hazards”) or other applications requiring a manual reset.

The configuration is selected via two banks of DIP switches located under the Module’s front cover (see Figures 1-2 and 3-2).

#### Monitored Manual Reset

Manual Reset is typically used in situations where the individual can pass through a sensing field and become clear of a safeguarding device, such that the device can no longer prevent hazardous motion (e.g., perimeter guarding). The Module “monitors” the input for two transitions: from open-to-closed, and from closed-to-open within a certain time period. This prevents the reset button from being tied down or failing in a closed condition, and causing an unintended or automatic reset.

Upon power-up, when the Module has been configured for manual reset, for the OSSD outputs to turn ON, both the MSSSI and the SSI must be active (closed) and a monitored manual reset must be accomplished. The reset is accomplished by closing the Reset input for a minimum of 1/4 second, but not longer than 2 seconds and then re-opening the input. The OSSD outputs will turn ON once the open-closed-open action occurs.

In this configuration, the Module must be manually reset after power-up, lockouts, and after the cycling of either the MSSSI (not muted) or the SSI. The location for the manual reset device (e.g., a normally open key switch) must comply with the warning in Section 3.5.1 and refer to that section for further information on key resets.

#### Automatic Reset

Upon power-up, when the Module is configured for automatic reset, the OSSD outputs will automatically turn ON once power is applied, the self-test is accomplished, and the MSSSI and the SSI are active (closed). The OSSD outputs will also turn ON after either interface is de-activated and then re-activated. In either case, no external input or reset is required.

Automatic reset is typically used in situations where the individual is continually sensed by the defined area or in situations where supplemental safeguards prevent the initiation of hazardous motion while an individual is within the safeguarded space (e.g., point-of-operation guarding).

In either case, a manual reset must be performed to recover from a lockout condition.

In Automatic Reset mode, input X1–X2 stays open.

### 1.4 Lockout Conditions

A lockout condition of the Module will cause both OSSD outputs to go OFF. A lockout condition is indicated by a flashing Red status indicator and an error number displayed on the Diagnostic Display.

A description of possible lockouts, their causes, troubleshooting hints, and a Manual Reset routine are listed in Section 5.

### 1.5 Control Reliability: Redundancy and Self-Checking

Redundancy requires that Module circuit components be “backed up” to the extent that, if the failure of a single component will prevent effective machine stopping action when needed, that component must have a redundant counterpart which will perform the same function. The microprocessor-controlled Muting Module is designed with diverse redundancy. Diverse-redundant components are of different designs, and microprocessor programs used by them run from different instruction sets.

Redundancy must be maintained for as long as the Muting Module is in operation. Since a redundant system is no longer redundant once a component has failed, the Module is designed to be continuously self-checking. A component failure detected by or within the self-checking system causes a “stop” signal to be sent to the guarded machine and puts the Module into a lockout condition.

Recovery from this type of lockout condition requires replacement of the failed component (to restore redundancy) and the appropriate reset procedure (see Section 3.5.1). Possible causes are listed in Section 5. The Diagnostic Display is used to diagnose causes of a lockout condition (Section 5).



### 1.6 Muteable Safety Stop Interface (MSSI)

The Muteable Safety Stop Interface (MSSI) input (S11–S12, S21–S22) is a specialized SSI that can be muted during the non-hazardous portion of the machine cycle.

The Module requires redundant input signals from the external primary safeguard which is to be muted. These inputs typically are either two Banner solid-state safety outputs or two monitored forced-guided relay outputs from an appropriate safety device. See Section 2, Specifications, and Section 3.5.6 for complete information.



#### **WARNING . . . Emergency Stop Functions**

**Do not connect any Emergency Stop devices to the MSSI Input; do not mute or bypass any Emergency Stop device.** ANSI NFPA79 and IEC/EN 60204-1 require that the Emergency Stop function remain active at all times. **Muting or bypassing the safety outputs will render the Emergency Stop function ineffective.**

### 1.7 Safety (Protective) Stop Interface (SSI)

The Module has a provision for an additional Safety (Protective) Stop Interface (X5–X6, X7–X8) to connect an optional device, such as a supplemental safeguard, E-stop button, or safety switch(es), to issue a stop command. This dual-channel interface is similar to the MSSI, but is always functional, even when the primary safety device is being muted. See Sections 2, Specifications, and 3.5.6 for complete information.

### 1.8 OSSD Outputs

Model MMD-TA-12B has two solid-state safety outputs (Y5–Y6, Y7–Y8); and model MMD-TA-11B has two normally open hard-contact safety outputs (13–14, 23–24), labeled “OSSD1” and “OSSD2” (see Figure 1-1). The solid-state safety outputs are actively monitored to detect short circuits to the supply voltage, to each other, and to other sources of electrical energy. If a failure is detected, the outputs will switch to an OFF-state. For circuits requiring the highest level of safety and reliability, either OSSD must be capable of stopping the motion of the guarded machine in an emergency.

During the muted portion of the machine cycle, the MSSI inputs will be ignored and OSSD1 and OSSD2 will remain ON. During other portions (not muted) of the cycle, if the MSSI either open or go OFF, OSSD1 and OSSD2 will go OFF.

In any case, if the SSI interface opens, OSSD1 and OSSD2 will go OFF. See Appendix A for timing diagrams.

### 1.9 Auxiliary Output (Aux)

The Auxiliary (Aux) monitoring PNP (Z3–Z4) output on the MMD-TA-12B and the parallel N.C. contact output on the -11B are intended for non-safety related purposes. The status of this auxiliary output is indicated by the green Status LED. See Section 3.5.4 for more information.

### 1.10 External Device Monitoring (EDM)

Two inputs are provided (see Figures 3-24 to 3-28) for monitoring the state of external devices, such as MPCEs. These terminals are labeled “EDM1” (Y1–Y2) and “EDM2” (Y3–Y4). The Module’s EDM inputs can be configured in three ways: one-channel, two-channel, or no monitoring (see Figure 3-2 for DIP switch settings and Section 3.7.2 for external hookup). One- and two-channel EDM are used when the OSSD outputs directly control the de-energizing of the MPCEs or external devices.

- **One-Channel Monitoring:** a series connection of closed monitor contacts that are forced-guided (mechanically linked) from each device controlled by the Muting Module. The monitor contacts must be closed before the Module can be reset (either Manual or Automatic). After a reset is executed and the safety outputs (OSSDs) are closed, the status of the monitor contacts is no longer monitored. However, the monitor contacts must be closed within 200 milliseconds of the OSSD outputs going from ON to OFF.
- **Two-Channel Monitoring:** an independent connection of closed monitor contacts that are forced-guided (mechanically linked) from each device controlled by the Muting Module. Both EDM inputs must be closed before the Module can be reset and the OSSDs can turn ON. While the OSSDs are ON, the inputs may change state (either both open, or both closed). If the inputs remain in opposite states for more than 200 milliseconds, a lockout will occur. Additionally, both inputs must be closed 200 milliseconds after the OSSD outputs go OFF, or a lockout will occur.
- **No Monitoring:** If no monitoring is desired, the 1-ch/2-ch selection switches must be configured for two-channel EDM, and Y1 must be jumpered to Y3. If the Module is set for No Monitoring, the user must ensure that any single failure of the external devices does not result in a hazardous condition and a successive machine cycle will be prevented (see Section 1.5, Control Reliability).

## 1.11 Mute Inputs (M1–M4) and Mute Devices

### The Muting Function

To mute the primary safeguard appropriately, the design of a muting system must:

1. Identify the non-hazardous portion of the machine cycle,
2. Involve the selection of the proper muting devices, and
3. Include proper mounting and installation of those devices.

The Module can monitor and respond to redundant signals that initiate the mute (M1: Z11–Z21; M2: Z12–Z22; M3: Z13–Z23; M4: Z14–Z24). The mute then suspends the safeguarding function by ignoring the state of the MSSl. This allows a person to interrupt the defined area to load and/or unload parts or an object to pass through the defined area of a safety light screen, without generating a stop command. (This should not be confused with blanking, which disables one or more beams in a safety light screen, resulting in larger resolution.) See Appendix A for example mute timing sequences.

The mute may be triggered by a variety of external devices. This feature provides a variety of options (see Sections 3.5.2 – 3.5.3) to tailor the System to the requirements of a specific application.

A pair of muting devices must be triggered simultaneously (within 3 seconds of one another). This reduces the chance of common mode failures or defeat.



### WARNING . . . Muting Limitations

Muting is allowed only during the non-hazardous portion of the machine cycle.

A muting application must be designed so that no single component failure can prevent the stop command or allow subsequent machine cycles until the failure is corrected (per OSHA 1910.217(c)(3)(iii)(d), and ANSI B11.19).



### WARNING . . . Mute Inputs Must Be Redundant

It is not acceptable to use a single switch, device, or relay with two N.O. contacts for the mute inputs. This single device, with multiple outputs, may fail so that the System is muted at an inappropriate time. This may result in a hazardous situation.

### Mute Devices

The beginning and end of a mute cycle must be triggered by outputs from either pair of muting devices, depending on the application. The mute device pairs both must have normally open contacts, or have one device with a PNP output and one device with an NPN output, both of which fulfill the “muting device requirements” in Sections 2 and 3.5.2. These contacts must close (conduct) when the switch is actuated to initiate the mute, and must open (non-conducting) when the switch is not actuated and in a power-OFF condition.

The Module monitors the mute devices to verify that their outputs turn ON within 3 seconds of each other. If the inputs do not meet this simultaneity requirement, a mute condition can not occur.

Several types and combinations of mute devices can be used, including, but not limited to: limit switches, photoelectric sensors, positive-driven safety switches, inductive proximity sensors, and “whisker” switches. (See Muting Device Requirements, Section 3.5.2.)

## 1.12 Mute Enable (ME)

The Mute Enable input (X13–X14) is a non-safety-rated input. When the input is closed (terminals X13–X14 jumpered), the Module will allow a mute condition to occur; opening this input while the System is muted will have no effect. The Module is factory-supplied with a jumper installed between terminals X13–X14. To use the Mute Enable function, remove the jumper.

Typical uses for Mute Enable include:

- To allow the machine control logic to create a “window” for muting to begin;
- To inhibit muting from occurring; or
- To reduce the chance of unauthorized or unintended bypassing or defeat of the safety system.

### Simultaneity Timer Reset Function

The Mute Enable input can also be used to reset the simultaneity timer of the mute inputs. If one input is active for longer than three seconds before the second input becomes active, the simultaneity timer will prevent a mute cycle from occurring. This could be due to a normal stoppage of an assembly line that may result in blocking one mute device and the simultaneity time running out.

If the ME input is cycled (closed-open-closed) while one mute input is active, the simultaneity timer is reset, and if the second mute input becomes active within three seconds, a normal mute cycle begins. The timing requirement for the closed-open-closed is similar to the manual reset function. Initially, the input needs to be active (closed) for longer than 1/4 second, then open for longer than 1/4 second, but not longer than 2 seconds, and then must reclose to reset the simultaneity timer. The function can reset the timer only once per mute cycle (i.e., all mute inputs M1–M4 must open before another reset can occur).

### 1.13 Mute Lamp Output (ML)

Some applications require that a lamp (or other means) be used to indicate when the safety device (e.g., light screen) is muted; the module provides for this (X3-X4; see Caution below). This indication is selectable between a monitored or a non-monitored output signal (NPN sinking). The monitored output will prevent the initiation of a mute after an indicator failure is detected (current draw falls below 10 mA or goes above 360 mA). If the application requires compliance with UL 61496, Lamp Monitoring must be selected and the lamp used must meet applicable requirements (see Section 3.5.3).



#### **CAUTION . . . Mute Status Must Be Readily Observable**

Indication that the safety device is muted should be provided and be readily observable.

**Failure of this indication should be detectable and prevent the next mute, or the operation of the indicator should be verified at suitable intervals.**

Lamp Monitoring must be selected if the application requires compliance with UL 61496.

### 1.14 Backdoor Timer

The Backdoor Timer allows the user to select a maximum period of time that muting is allowed to occur. This feature hinders the intentional defeat of the muting devices to initiate an inappropriate mute. It is also useful for detecting a common mode failure that would affect all mute devices in the application.

The timer begins when the second muting device makes the simultaneity requirement (within 3 seconds of the first device), and will allow a mute to continue for the predetermined time. After the timer expires, the mute ends – no matter what the signals from the mute devices indicate. If the MSSI is open, the OSSD outputs will turn OFF and must be manually reset (if Module is configured for Manual Reset). The Override function can be activated (see Section 1.16) to force the OSSDs ON in order to clear the obstruction.

If the Backdoor Timer expires, a #50 error code will be displayed until all mute device inputs are open and the MSSI is active (closed).

The Backdoor Timer can be disabled (i.e., set for infinite time). See Figure 3-2 and configure DIP switches #7 and #8 for Backdoor Time-Out OFF.



#### **WARNING . . . Backdoor Timer**

**An infinite time for the backdoor timer (i.e., disabling) should be selected only if the possibility of an inappropriate or unintended mute cycle is minimized, as determined and allowed by the machine's risk assessment. It is the user's responsibility to ensure that this does not create a hazardous situation.**

### 1.15 Mute on Power-Up

Mute Enable must be closed to allow Mute on Power-Up. (See Warning below.) If selected, the Mute on Power-Up function will initiate a mute when power is applied, the Mute Enable input is closed, the MSSI inputs are active (closed), and either M1-M2 or M3-M4 (but not all four) are closed.

If Auto Reset is configured, the Module allows 10 seconds for the MSSI and SSI to become active (closed) to accommodate systems that may not be immediately active at power-up.

If Manual Reset is configured, the first valid reset after the MSSI and SSI are active (closed) will result in a mute cycle if all other conditions are satisfied.



#### **WARNING . . . Mute on Power-Up**

**The Mute on Power-Up function should be used only in applications where:**

- **Muting the System (M1 and M2 closed) when power is applied is required, and**
- **Using it must not, in any situation, expose personnel to any hazard.**



## 1.16 Override

The Override function (X9–X10, X11–X12) allows the user to manually force the OSSD outputs ON for up to 30 seconds in a situation such as an object becoming “stuck” in the defined area of a safety light screen after the mute ends (e.g., a car body on a transfer line entering a work cell). The feature is intended to allow the user to “jog” the part out of the defined area. The need to perform an Override is indicated by a flashing mute lamp.

This input requires two normally open switches, both of which must be closed within 3 seconds of each other. The Override cycle will last a maximum of 30 seconds, after which the Override input must be released for at least 0.5 seconds prior to the next Override cycle. An Override can be initiated only after tripping of the MSSl inputs causes the Module to latch its OSSDs OFF.

NOTE: A stop command issued by the SSI cannot be overridden.

When Override is used, the following precautions must be taken:

- Prevent exposure to any hazard during an Override cycle,
- Provide a readily observable indication of an Override, and
- Provide supplemental safeguarding, per ANSI NFPA79 and IEC/EN60204-1.

The Override switches must be supervised and must prevent automatic operation. Also, one or more of the following must be true:

- Motion is initiated by a hold-to-run or similar device,
- If a portable control station (e.g., an enabling device) with an emergency stop device is used, motion may be initiated only from that station,
- Motion, speed, or power of the machine is limited, or
- The machine’s range of motion is limited.



### **WARNING . . . Limit Use of Override Function**

**The Override function is not for machine setup or production; it is to be used only to clear the primary safety device, such as if material becomes “stuck” in the defined area of a safety light screen.**

When Override is used, it is the user’s responsibility to install and use it according to current standards (see inside back cover).

In addition, the requirements listed in standards ANSI NFPA79 or IEC/EN60204-1 must be satisfied.

## 1.17 One-Way/Two-Way Muting

One-way (directional) muting allows the safeguard to be muted only if mute devices are actuated in the order M1, M2, (mute initiated), M3, and M4. This method allows for a single-direction material flow and reduces the possibility of intentional defeat of the muting devices.

Two-way (non-directional) muting allows the safeguard to be muted any time the actuation of M1–M2 or M3–M4 meets the 3-second simultaneity requirement. This allows the flow of material from either direction (two-way material flow).

NOTE: When using four mute devices (M1, M2, M3 and M4), in order to extend the mute until the light screen is clear, the object must activate all four of the devices at one time during the mute cycle.

## 1.18 Designated and Qualified Persons

For the purposes of this manual, the following definitions apply:

**Designated Person:** A person or persons identified and designated in writing, by the employer, as being appropriately trained and qualified to perform a specified checkout procedure.

**Qualified Person:** A person or persons who, by possession of a recognized degree or certificate of professional training, or who, by extensive knowledge, training, and experience, has successfully demonstrated the ability to solve problems relating to the implementation of this safety system.

## 2. Components and Specifications

### 2.1 Specifications

<b>System Power Requirements</b>	<b>Model MMD-TA-11B:</b> +24V dc $\pm 15\%$ @ 300 mA max (SELV/PELV) <b>Model MMD-TA-12B:</b> +24V dc $\pm 15\%$ @ 250 mA max (SELV/PELV) (not including draw of the MSSl power, AUX, ML, M1-M4 and OSSD connections). The external voltage supply must be capable of buffering brief mains interruptions of 20 ms, as specified in IEC/EN 60204-1.																				
<b>Overvoltage Category</b>	III (IEC 60664-1)																				
<b>Pollution Degree</b>	2																				
<b>Supply Protection Circuitry</b>	All inputs and outputs are protected from short circuit to +24V dc or dc common.																				
<b>Response Time (MSSl and SSl)</b>	<b>Model MMD-TA-11B:</b> (relay output) 20 ms max. <b>Model MMD-TA-12B:</b> (solid-state output) 10 ms max.																				
<b>Safety Outputs</b> (see Warning on pages 32-34)	<p><b>Model MMD-TA-11B:</b>  <b>2 normally open contact output channels and 1 normally closed auxiliary contact output channel:</b> Each normally open output channel is a series connection of contacts from two forced-guided (positive-guided) relays, K1-K2. The normally closed AUX contact (non-safety) 31-32 is a parallel connection of contacts from K1-K2.</p> <p><b>Contacts:</b> AgNi, 5 <math>\mu</math>m gold-plated</p> <p><b>Low Current Rating:</b>  <b>Caution: The 5 <math>\mu</math>m gold-plated contacts allow the switching of low current/low voltage.</b>                      In these low-power applications, multiple contacts can also be switched in series (e.g., “dry switching”).                      To preserve the gold plating on the contacts and also guarantee reliable switching, the following values should be kept within the min. and max. ranges shown below:</p> <table border="0" style="width: 100%;"> <tr> <td><b>Min. voltage:</b> 1V ac/dc</td> <td><b>Max. voltage:</b> 60V</td> </tr> <tr> <td><b>Min. current:</b> 5 mA ac/dc</td> <td><b>Max. current:</b> 300 mA</td> </tr> <tr> <td><b>Min. power:</b> 5 mW (5 mVA)</td> <td><b>Max. power:</b> 7 W (7 VA)</td> </tr> </table> <p><b>High Current Rating:</b>                      If higher loads must be switched through one or more of the contacts, the minimum and maximum values of the contact(s) changes to:</p> <table border="0" style="width: 100%;"> <tr> <td><b>Min. voltage:</b> 15V ac/dc</td> <td><b>Max. voltage:</b> 120V ac/dc</td> </tr> <tr> <td><b>Min. current:</b> 30 mA ac/dc</td> <td><b>Max. current:</b> 6 A</td> </tr> <tr> <td><b>Min. power:</b> 0.45 W (0.45 VA)</td> <td><b>Max. power:</b> 160 W (720 VA)</td> </tr> </table> <p><b>Mechanical life:</b> 50,000,000 operations  <b>Electrical life:</b> 120,000 operations (typical, @ 144 W [1,380 VA] switched power, resistive load)  <b>NOTE: Transient suppression is recommended when switching inductive loads. Install suppressors across load. Never install suppressors across output contacts (see Warning, page 35).</b></p> <hr/> <p><b>Model MMD-TA-12B:</b>  <b>2 diverse-redundant solid-state safety outputs:</b> 24V dc, 0.5 A sourcing OSSD (output signal switching device).</p> <table border="0" style="width: 100%;"> <tr> <td><b>ON-State voltage:</b> <math>\geq V_{in} - 1.5V</math> dc</td> <td><b>Cable resistance:</b> 10 ohms maximum</td> </tr> <tr> <td><b>OFF-State voltage:</b> 1.2V dc max. (0–1.2V dc)</td> <td><b>OSSD test pulse width:</b> &lt; 100 <math>\mu</math>s</td> </tr> <tr> <td><b>Max. load capacitance:</b> 1.0 <math>\mu</math>F</td> <td><b>OSSD test pulse period:</b> &gt; 100 ms</td> </tr> <tr> <td><b>Max. load inductance:</b> 10 H</td> <td><b>Switching current:</b> 0–0.5 A</td> </tr> </table> <p><b>Leakage current:</b> 0.50 mA maximum</p>	<b>Min. voltage:</b> 1V ac/dc	<b>Max. voltage:</b> 60V	<b>Min. current:</b> 5 mA ac/dc	<b>Max. current:</b> 300 mA	<b>Min. power:</b> 5 mW (5 mVA)	<b>Max. power:</b> 7 W (7 VA)	<b>Min. voltage:</b> 15V ac/dc	<b>Max. voltage:</b> 120V ac/dc	<b>Min. current:</b> 30 mA ac/dc	<b>Max. current:</b> 6 A	<b>Min. power:</b> 0.45 W (0.45 VA)	<b>Max. power:</b> 160 W (720 VA)	<b>ON-State voltage:</b> $\geq V_{in} - 1.5V$ dc	<b>Cable resistance:</b> 10 ohms maximum	<b>OFF-State voltage:</b> 1.2V dc max. (0–1.2V dc)	<b>OSSD test pulse width:</b> < 100 $\mu$ s	<b>Max. load capacitance:</b> 1.0 $\mu$ F	<b>OSSD test pulse period:</b> > 100 ms	<b>Max. load inductance:</b> 10 H	<b>Switching current:</b> 0–0.5 A
<b>Min. voltage:</b> 1V ac/dc	<b>Max. voltage:</b> 60V																				
<b>Min. current:</b> 5 mA ac/dc	<b>Max. current:</b> 300 mA																				
<b>Min. power:</b> 5 mW (5 mVA)	<b>Max. power:</b> 7 W (7 VA)																				
<b>Min. voltage:</b> 15V ac/dc	<b>Max. voltage:</b> 120V ac/dc																				
<b>Min. current:</b> 30 mA ac/dc	<b>Max. current:</b> 6 A																				
<b>Min. power:</b> 0.45 W (0.45 VA)	<b>Max. power:</b> 160 W (720 VA)																				
<b>ON-State voltage:</b> $\geq V_{in} - 1.5V$ dc	<b>Cable resistance:</b> 10 ohms maximum																				
<b>OFF-State voltage:</b> 1.2V dc max. (0–1.2V dc)	<b>OSSD test pulse width:</b> < 100 $\mu$ s																				
<b>Max. load capacitance:</b> 1.0 $\mu$ F	<b>OSSD test pulse period:</b> > 100 ms																				
<b>Max. load inductance:</b> 10 H	<b>Switching current:</b> 0–0.5 A																				



Specifications continued on page 9.

## 2.1 Specifications, continued

Non-Safety Outputs	<p><b>Model MMD-TA-11B:</b>  Aux. output 31–32 is a parallel connection of two N.C. contacts from internal relays K1 and K2.  <b>Contact:</b> AgNi, 5 <math>\mu</math>m gold-plated  <b>Low Current Rating:</b>  <b>Caution: The 5 <math>\mu</math>m gold-plated contacts allow the switching of low current/low voltage.</b> To preserve the gold plating on the contacts and also guarantee reliable switching, the following values should be kept within the min. and max. ranges shown below:</p> <table> <tr> <td><b>Min. Voltage:</b> 1V ac/dc</td> <td><b>Max. Voltage:</b> 24V ac/dc</td> </tr> <tr> <td><b>Min. Current:</b> 5 mA ac/dc</td> <td><b>Max. Current:</b> 250 mA ac/dc</td> </tr> <tr> <td><b>Min. Power:</b> 5 mW (5 mVA)</td> <td><b>Max. Power:</b> 6 W (6VA)</td> </tr> </table> <p><b>High Current Rating:</b>  For higher loads, the min. and max. values of the contact(s) changes to:</p> <table> <tr> <td><b>Min. Voltage:</b> 15V ac/dc</td> <td><b>Max. Voltage:</b> 24V ac/dc</td> </tr> <tr> <td><b>Min. Current:</b> 30 mA ac/dc</td> <td><b>Max. Current:</b> 250 mA ac/dc</td> </tr> <tr> <td><b>Min. Power:</b> 0.45 W (0.45VA)</td> <td><b>Max. Power:</b> 6 W (6VA)</td> </tr> </table> <p><b>Mechanical Life:</b> 50,000,000 operations  <b>Electrical Life:</b> &gt;10 x 10<sup>6</sup> cycles</p>	<b>Min. Voltage:</b> 1V ac/dc	<b>Max. Voltage:</b> 24V ac/dc	<b>Min. Current:</b> 5 mA ac/dc	<b>Max. Current:</b> 250 mA ac/dc	<b>Min. Power:</b> 5 mW (5 mVA)	<b>Max. Power:</b> 6 W (6VA)	<b>Min. Voltage:</b> 15V ac/dc	<b>Max. Voltage:</b> 24V ac/dc	<b>Min. Current:</b> 30 mA ac/dc	<b>Max. Current:</b> 250 mA ac/dc	<b>Min. Power:</b> 0.45 W (0.45VA)	<b>Max. Power:</b> 6 W (6VA)
	<b>Min. Voltage:</b> 1V ac/dc	<b>Max. Voltage:</b> 24V ac/dc											
<b>Min. Current:</b> 5 mA ac/dc	<b>Max. Current:</b> 250 mA ac/dc												
<b>Min. Power:</b> 5 mW (5 mVA)	<b>Max. Power:</b> 6 W (6VA)												
<b>Min. Voltage:</b> 15V ac/dc	<b>Max. Voltage:</b> 24V ac/dc												
<b>Min. Current:</b> 30 mA ac/dc	<b>Max. Current:</b> 250 mA ac/dc												
<b>Min. Power:</b> 0.45 W (0.45VA)	<b>Max. Power:</b> 6 W (6VA)												
<p><b>Model MMD-TA-12B:</b>  Z4–Z3 = Aux. 24V / 250 mA PNP output follows the two OSSD safety outputs.</p>													
Status Indicator LEDs	<p><b>3 Status Indicator LEDs (Red, Green and Yellow):</b> indicate waiting for Reset, Lockout, Override, and OSSD status  <b>Yellow and Green LEDs</b> adjacent to individual inputs/interfaces indicate status (ON = active/ closed)</p>												
Diagnostic Code Display	<p>Diagnostic Display is a two-digit numeric display that indicates the cause of lockout conditions and the amount of time remaining for the backdoor timer.</p>												
Muting Lamp Output	<p>A monitored or non-monitored (selectable) sinking output. If monitoring has been selected, the current draw must be 10 mA to 360 mA. Interconnect wire resistance &lt; 30 ohms.  <b>Maximum Switching Voltage:</b> 30V dc  <b>Maximum Switching Current:</b> 360 mA  <b>Minimum Switching Current:</b> 10 mA  <b>Saturation Voltage:</b> <math>\leq 1.5V</math> dc @ 10 mA; <math>\leq 5V</math> dc @ 360 mA</p>												
Controls and Adjustments	<p><b>All configured on 2 redundant banks of DIP switches:</b>  Manual/auto reset  One-way/two-way muting  Monitored/non-monitored mute lamp output  One-channel/two-channel/no EDM  Backdoor timer  Mute on power-up enable</p>												

Specifications continued on page 10.

### 2.1 Specifications, continued

<b>Inputs</b>	<p>The MSSSI and the SSI can be interfaced with external devices that have either hard contact outputs or solid state sourcing outputs.</p> <p>When connecting the MSSSI (S11–S12, S21–S22) or SSI (X5–X6, X7–X8) inputs to relay outputs or hard contacts, these contacts must be capable of switching 15–30V dc at 10–50 mA.</p> <p><b>Operating Range for MSSSI and SSI Inputs</b>  <b>OFF State:</b> -3V to +5V, 0 to 2 mA  <b>ON State:</b> 15–30V, 10–50 mA</p> <p><b>Muteable Safety Stop Interface (MSSSI)</b>  This input consists of two channels (MSSSI-A and MSSSI-B), and can be muted when the requirements for a mute cycle have been met. When muted, the OSSDs remain ON, independent of the MSSSI status. If not muted, anytime either or both channels open, the OSSD outputs will go OFF. <i>Maximum external resistance per channel must not exceed 400 Ω. (See Section 3.5.6 for further information.)</i></p> <p><b>Safety Stop Interface (SSI)</b>  This input consists of two channels (SSI-A and SSI-B), and is always active. Any time either or both channels open, the OSSD Outputs will go OFF. <i>Maximum external resistance per channel must not exceed 400 Ω. (See Section 3.5.6 for further information.)</i></p>
<b>External Device Monitoring (EDM)</b>	<p>Two pairs of terminals are provided to monitor the state of external devices controlled by the OSSD outputs. Each device must be capable of switching 15–30V dc at 10–50 mA.</p>
<b>Muting Device Inputs</b>	<p>The muting devices work in pairs (M1 and M2, M3 and M4) and are required to be “closed” within 3 seconds of each other (simultaneity requirement/synchronous actuation) to initiate a mute (assuming all other conditions are met). Each muting device must be capable of switching 15–30V dc at 10–50 mA.</p>
<b>Mute Enable Input</b>	<p>The Mute Enable input must have +24V dc applied in order to start a mute; opening this input after mute has begun has no effect. The switching device must be capable of switching 15–30V dc at 10–50 mA.</p>
<b>Override Inputs</b>	<p>The two-channel inputs must be closed within 3 seconds of each other (simultaneity/synchronous action requirement) and held closed during the 30-second Override. To initiate a subsequent Override, open both channels, wait 3 seconds, and then re-close both channels (within 3 seconds). The switching devices must be capable of switching 15–30V dc at 10–50 mA.</p>
<b>Reset Input</b>	<p>Terminals must be closed for a minimum of 0.25 seconds and not more than 2.0 seconds in order to guarantee a reset. The switching device must be capable of switching 15–30V dc at 10–50 mA.</p>
<b>Mounting</b>	<p>Mounts to standard 35 mm DIN-rail track.</p>
<b>Vibration Resistance</b>	<p>10 to 55 Hz @ 0.35 mm displacement per IEC 68-2-6.</p>
<b>Construction</b>	<p>Polycarbonate housing. See Section 2.3 for dimensions.</p>
<b>Environmental Rating</b>	<p>Rated NEMA 1; IEC IP20. Safety Module must be installed inside an enclosure rated NEMA 3 (IEC IP54) or better.</p>
<b>Connections</b>	<p>Removable terminal blocks; see Figure 3-4 for terminal locations.</p>
<b>Operating Conditions</b>	<p><b>Temperature range:</b> 0° to +50° C (+32° to 122° F)  <b>Max. Relative Humidity:</b> 95% (non-condensing)  <b>Heat Dissipation Considerations:</b> See Section 3.2 “Installing the Module”.</p>
<b>Safety Ratings</b>	<p>Category 4 (EN954-1); SIL 3 (IEC 61508 &amp; 62061); SIL CL 3 (IEC 62061);  Category 4, Performance Level (PL) e (ISO 13849-1)</p>
<b>Certifications*</b>	<div style="display: flex; align-items: center;"> <div style="margin-right: 20px;">  <p>Category 4 (EN954-1)  SIL 3 (IEC 61508 &amp; 62061)  Category 4, PL e (ISO 13849-1)</p> </div> <div style="margin-right: 20px;">  <p>UL LISTED US ESPE 10GH</p> </div> <div> <p>NIPF  UL 1998  UL 61496</p> </div> </div>

\*Contact the factory for IEC 61508/62061 and ISO 13849-1 data.

Specifications continued on page 11.

### 2.1 Specifications, continued

<b>Application Notes</b>	<b>Mute Timing Sequences:</b> see Appendix A <b>Typical Muting Applications:</b> see Appendix B <b>Application Standards:</b> see inside back cover
--------------------------	---

### 2.2 Accessories

#### Solid-State LED-Based Mute Lamp

<b>SSA-ML-W</b>	+24V dc, White lens, stack-light style on 12" pole (see data sheet p/n 62097)
<b>SSA-ML-A</b>	+24V dc, Amber lens, stack-light style on 12" pole (see data sheet p/n 62097)
<b>M18RGR5PNQ</b>	+24V dc, Red, Green, Amber indication, M18 EZ-LIGHT™ with 4-pin Euro-style QD

### 2.3 Dimensions

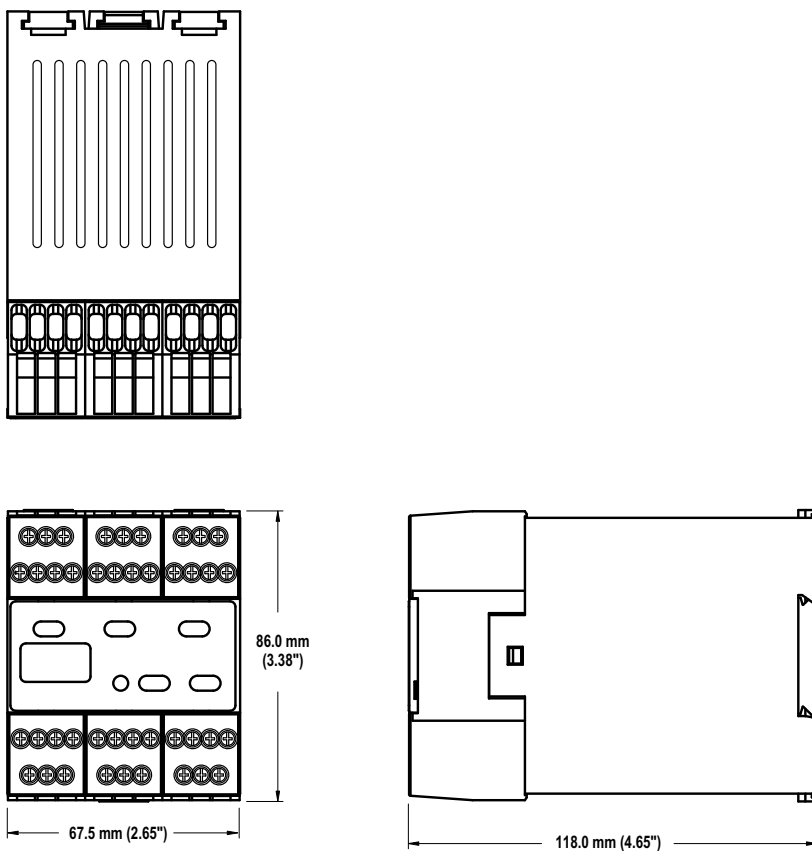



## 3. System Installation

### 3.1 Appropriate Application

The correct application of the MMD-TA-11B and -12B Muting Modules is dependent on the type of machine and the safeguards that are to be interfaced with the Module. The Module is generally interfaced with safeguards that may be used only on machinery that is capable of stopping motion immediately upon receiving a stop signal and at any point in its machine cycle. It is the user's responsibility to verify whether the safeguarding is appropriate for the application and is installed as instructed by the appropriate installation manuals.

**Safety Light Screens, Single/Multiple Beam Safety Systems, or other Presence-Sensing Safeguarding Devices (PSSDs) generally may not be used for the following:**

- With single stroke (also called "full revolution") clutched machinery, as this type of machinery is incapable of stopping immediately.
- On certain other types of machinery, including any machine with inadequate or inconsistent stopping response time, or any machine that ejects materials or component parts through the defined area.
- In any environment likely to adversely affect the efficiency of the safeguard(s) or the Muting Module. For example, corrosive chemicals or fluids or unusually severe levels of smoke or dust, if not controlled, may degrade the efficiency of a safety light screen.

If there is any doubt about whether or not your machinery is compatible with this Muting Module, contact Banner's Application Engineers at the factory.



#### **WARNING . . . Stand-Alone Point-of-Operation Guarding**

The Muting Module is not a stand-alone point-of-operation guarding device, as defined by OSHA regulations. It is necessary to install point-of-operation guarding devices, such as safety light screens and/or hard guards, to protect personnel from hazardous machinery.

**Failure to properly install point-of-operation safeguarding on hazardous machinery, as instructed by the appropriate installation manuals, can result in a dangerous condition which could lead to serious injury or death.**



#### **WARNING . . . Read this Section Carefully Before Installing the System**

The Banner MMD-TA-11B or -12B Muting Module is an accessory device that is typically used in conjunction with a machine safeguarding device. **Its ability to perform this function depends upon the appropriateness of the application and upon the Muting Module's proper mechanical and electrical installation and interfacing to the machine to be guarded.**

**If all mounting, installation, interfacing, and checkout procedures are not followed properly, the Muting Module cannot provide the protection for which it was designed.** The user has the responsibility to ensure that all local, state, and national laws, rules, codes, or regulations relating to the installation and use of this control system in any particular application are satisfied. Extreme care should be taken to ensure that all legal requirements have been met and that all technical installation and maintenance instructions contained in this manual are followed. **Read Section 3 (and its subsections) of this manual carefully before installing the system. Failure to follow these instructions could result in serious bodily injury or death.**

The user has the sole responsibility to ensure that this Muting Module is installed and interfaced to the guarded machine by Qualified Persons (see Section 1.18), in accordance with this manual and applicable safety regulations.



#### **WARNING . . . User Is Responsible for Safe Application of this Product**

The muting application examples described in Appendix B depict generalized guarding situations. Every guarding application has a unique set of requirements.

**Extreme care is urged to ensure that all legal requirements are met and that all installation instructions are followed. In addition, any questions regarding safeguarding should be directed to the factory applications department at the number or addresses listed on the front cover.**

### 3.1.1 Muting Application Design

Following are typical applications where muting is used. See Appendix B for more detailed information.

- **Entry/Exit Applications.** The muting devices are placed to allow the entry or exit of a pallet or cart of work materials to enter or exit a workstation without tripping the safety light screen, and without allowing the entrance of personnel into the hazardous area.
- **Home or Station Applications.** The muting devices must be placed to mute the safety light screen only when a hazard does not exist or is in another area — so that personnel are not exposed to any hazard.
- **Robot Load/Unload Station Application.** The “Station” muting application uses independent safety light screen circuits, each with its own muting circuit and sensors to protect work locations. When a robot is active in Station A, for example, Station B safety light screen is muted.
- **Turret Table Application.** A “Turret Table” application is similar to the Robot Load/Unload Station muting application, except that any movement of the table ends the mute.
- **Power Press Applications.** The muting devices are placed so that the mute is initiated only during the non-hazardous, opening portion of the cycle (typically the machine upstroke).



#### WARNING . . . Muting Limitations

Muting is allowed only during the non-hazardous portion of the machine cycle (OSHA 1910.217(c)(3)(iii)(d), and ANSI B11.19).

### 3.1.2 Use of Corner Mirrors with Optical Safety Systems

Mirrors are typically used with safety light screens and single-/multiple-beam safety systems to guard multiple sides of a hazardous area. If the safety light screen is muted, the safeguarding function is suspended on all sides. It must not be possible for an individual to enter the guarded area without being detected and a stop command issued to the machine control. This supplemental safeguarding is normally provided by an additional device(s) that remains active while the Primary Safeguard is muted and could be interfaced with the SSI input. Therefore, mirrors are typically not allowed for muting applications.

### 3.1.3 Multiple Presence-Sensing Safety Devices (PSSDs)

Muting multiple PSSDs or a PSSD with multiple sensing fields is not recommended unless it is not possible for an individual to enter the guarded area without being detected and a stop command issued to the machine control. As with the use of corner mirrors (see above), if multiple sensing fields are muted the possibility exists that personnel could move through a muted area or access point to enter the safeguarded area without being detected.

For example, in an entry/exit application where a pallet initiates the mute cycle by entering a cell, if both the entry and the exit PSSDs are muted, it may be possible for an individual to access the guarded area through the “exit” of the cell. An appropriate solution would be to mute the entry and the exit with separate safeguarding devices.



#### WARNING . . . Guarding Multiple Areas

DO NOT safeguard multiple areas, with mirrors or multiple sensing fields, if personnel can enter the hazardous area while the System is muted, and not be detected by supplemental safeguarding that will issue a stop command to the machine (see Section 3.1.4, Pass-Through Hazards).

## 3.1.4 Pass-Through Hazards

A “pass-through hazard” is associated with applications where personnel may pass through a safeguard (at which point the hazard stops or is removed), and then may continue into the hazardous area. Subsequently, their presence is no longer detected, and the safeguard can not prevent the start or restart of the machine. The related danger is the unexpected start or restart of the machine while personnel are within the hazardous area.

In the use of safety light screens, a pass-through hazard typically results from large separation/safety distances calculated from long stopping times, large defined area resolution, reach over, reach through, or other installation considerations. A pass-through hazard can be generated with as little as 75 mm (3") between the defined area and the machine frame or hard guarding.

### Reducing or Eliminating Pass-Through Hazards

Measures must be taken to eliminate or reduce pass-through hazards. One solution is to ensure that personnel are continually sensed while within the hazardous area. This can be accomplished by using supplemental safeguarding, including: safety mats, area scanners, and horizontally mounted safety light screens. While it is recommended to eliminate the pass-through hazard altogether, this may not be possible due to cell or machine layout, machine capabilities, or other application considerations.

An alternate method is to ensure that once the safeguarding device is tripped it will latch, and require a deliberate manual action to reset. This type of supplemental safeguarding relies upon the location of the reset switch as well as safe work practices and procedures to prevent an unexpected start or restart of the guarded machine.

The reset switch or actuating control must be positioned outside the guarded area, and provide the switch operator with a full unobstructed view of the entire guarded area and any associated hazards as the reset is performed. The reset switch or actuating control must not be reachable from within the guarded area and must be protected (through the use of rings or guards) against unauthorized or inadvertent operation. A key-actuated reset switch provides some operator control, as it can be removed by the operator and taken into the guarded area. However, this does not prevent unauthorized or inadvertent resets due to spare keys in the possession of others, or additional personnel entering the safeguarded area unnoticed.

The reset of a safeguard must not initiate hazardous motion. Also, before each reset of the safeguard is performed, safe work procedures require that a start-up procedure be followed and that the individual performing the reset verify that the entire hazardous area is clear of all personnel. If any areas can not be observed from the reset switch location, additional supplemental safeguarding must be used: at a minimum, visual and audible warnings of machine start-up.



### **WARNING . . . Pass-Through Hazards, Presence-Sensing Safeguarding Devices, and Muting**

**If the presence-sensing safeguarding device (PSSD) is guarding an application in which personnel have access into the sensing area or field (for example, a machine operator at the point of operation) while the PSSD is muted, all pass-through hazards must be eliminated. The individual must be sensed continually while in the safeguarded area; this will prevent initiation of a machine cycle if the mute ends while the individual is within the hazardous area. See Appendix B for examples.**

**If the pass-through hazard cannot be eliminated, as in entry/exit applications, the individual must be detected entering the safeguarded area and the hazardous motion must stop immediately.**

## 3.2 Installing the Module

The Muting Module mounts to a standard 35 mm DIN-rail track. The Module must be installed inside an enclosure rated NEMA 3 (IEC IP 54) or better. It can be mounted in any orientation. It must be used with a properly installed and applied safeguard (e.g., safety light screen, interlocked barrier guard). The user must comply with all instructions contained within product manuals and relevant regulations.

For reliable operation, the user must ensure that the operating specifications are not exceeded. The enclosure must provide adequate heat dissipation, so that the air closely surrounding the Module does not exceed its maximum operating temperature. Methods to reduce heat build-up include venting, forced air flow (e.g., exhaust fans), adequate enclosure exterior surface area, and spacing between Modules and other sources of heat. (See Specifications, “Operating Conditions.”)

Mount the Module in a convenient location that is free from heavy impulse force and high-amplitude vibration.

Electrostatic Discharge (ESD) can cause damage to electronic equipment. To prevent this, follow proper ESD handling practices such as:

- Wear an approved wrist strap or other approved grounding products.
- Touch a grounded object before handling the Module.

See ANSI/ESD S20.20 for further information about managing ESD.

### 3.3 Muting Module Configuration

The Muting Module should be configured before initial checkout and use. Two banks of DIP switches are located under the front cover. To access the DIP switches, use a screwdriver to gently pry the cover loose from the Module housing.

Because the Module has redundant microprocessors, two DIP switch banks (Bank A and Bank B) must be set identically. Failure to set Bank A and Bank B identically will result in a lockout condition. Power must be OFF when changing DIP switch settings; changing settings while power is ON will cause a lockout condition. The parameters to be manually configured are shown in Figure 3-2.

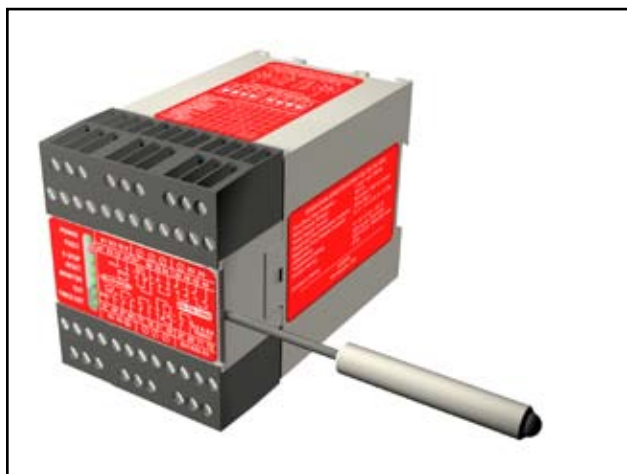

Figure 3-3. Use a screwdriver to gently pry the cover loose from the Module housing.

**Factory Default Settings**

ON  
↑  
OFF

1 2 3 4 5 6 7 8

NOTE: Switch numbers, e.g. "SW 1," refer to both switch banks A and B.

Switch	ON Position	OFF Position
1 <b>Auto/Manual MSSI Reset</b> (See Section 1.3)	MSSI auto reset	MSSI manual reset*
2 <b>Auto/Manual SSI Reset</b> (See Section 1.3)	SSI auto reset	SSI manual reset*
3 <b>One-Way or Two-Way Mute Initiate Sequence</b> (See Section 1.17)	Two-way muting	One-way muting*
4 <b>One-Channel or Two-Channel EDM</b> (See Section 1.10)	One-channel EDM	Two-channel or no EDM*
5-6 <b>Backdoor Time-Out</b> (See Section 1.14)	<b>5 ON, 6 ON</b>	<b>5 ON, 6 OFF</b>
	No backdoor time-out (infinite)	30-minute backdoor time-out
	<b>5 OFF, 6 ON</b>	<b>5 OFF, 6 OFF</b>
	60-second backdoor time-out	30-second backdoor time-out*
7 <b>Monitored/Non-Monitored Mute Lamp</b> (See Section 1.12)	Mute lamp not monitored	Mute lamp monitored*
8 <b>Mute on Power-Up</b>	Mute on power-up	No mute on power up*

\* Factory default setting

Figure 3-2. Muting Module manual configuration parameters

### 3.4 Connection Terminals and Functions

All electrical connections are made through removable terminals (see Figures 3-4a and 3-4b).

To disable the SSI, terminal X5 (SS1b) must be jumpered to terminal X6 (SS1a), and terminal X7 (SS1d) must be jumpered to terminal X8 (SS1c) (factory default). Do not short Channel A to Channel B.



### WARNING . . . Proper Electrical Hookup

Electrical hookup must be made by Qualified Personnel and must comply with NEC (National Electrical Code) and local standards.

Make no connections to the System other than those described in Section 3 of this manual. **Doing so could result in serious injury or death.**

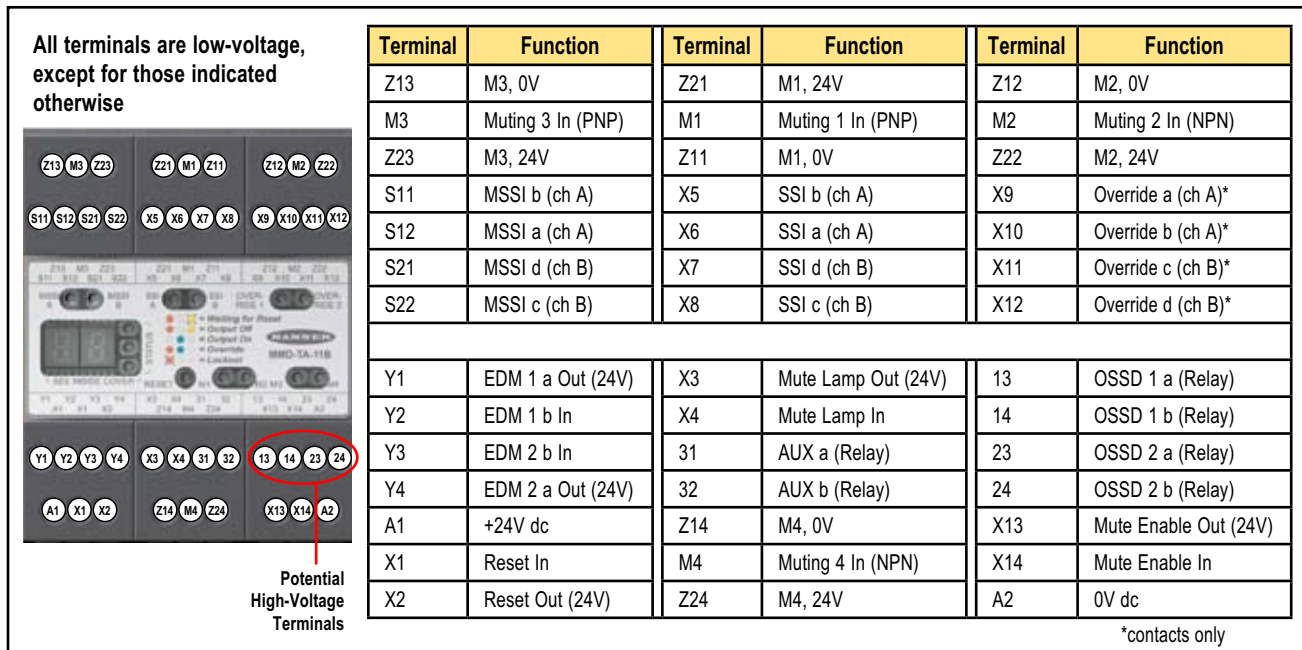

Figure 3-4a. MMD-TA-11B terminal connection locations

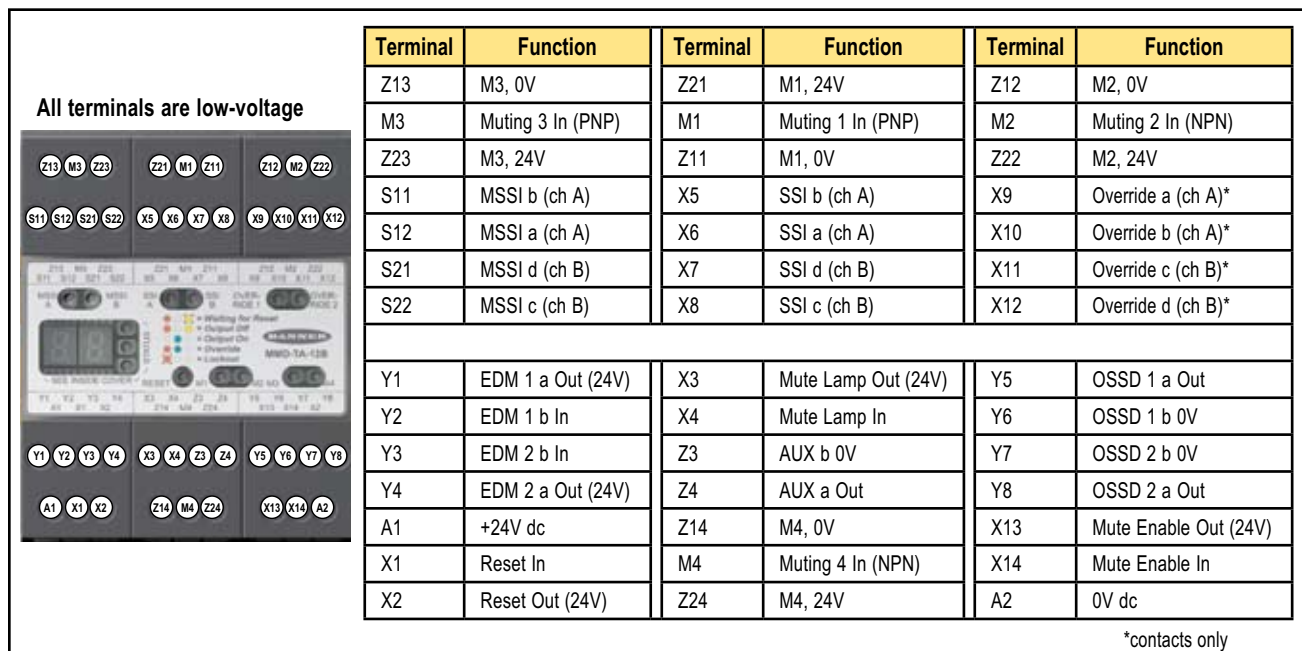

Figure 3-4b. MMD-TA-12B terminal connection locations



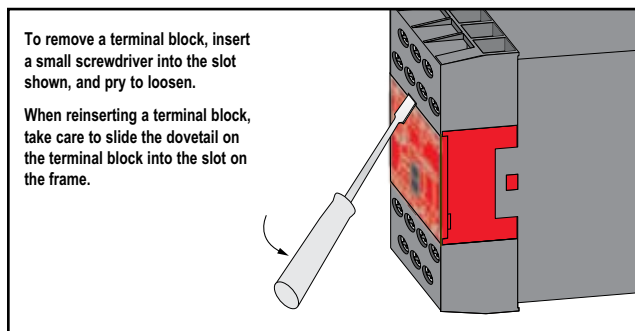

Figure 3-5. Removal of terminal blocks

## 3.5 Installing Input Devices

### 3.5.1 Manual Reset Switch

The manual reset switch connects to Module terminals X1 and X2 (see Figure 3-6). See Section 3.3 for Auto/Manual Reset configuration.

Any reset switches must be located so that a reset is possible only from outside, and in full view of, the hazardous area. The switch must also be out of reach from within the safeguarded space. If any hazardous areas are out of view from the switch location, additional means of safeguarding must be provided.

The switch must be protected from accidental or unintended actuation (e.g., through the use of rings or guards).

Using a key switch provides some level of personal control, because the key may be removed. This will hinder a reset while the key is under the control of an individual, but must not be relied upon solely to guard against accidental or unauthorized reset. Spare keys in the possession of others, or additional personnel entering the safeguarded area unnoticed may create a hazardous situation.

### Reset Routine

The Muting Module requires a manual reset to clear a latch condition and resume operation following a stop command. To perform a manual reset, close the normally open reset switch and hold it there for at least 1/4 second, but not longer than 2 seconds, and then re-open the switch. Internal lockout conditions also require a manual reset to return the system to RUN mode after the failure has been corrected and the input correctly cycled.

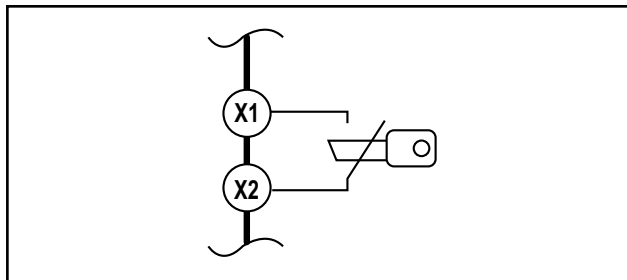

Figure 3-6. Manual Reset switch connections



### WARNING . . . Location of the Manual Reset Switch

The reset switch must be located outside of, and not be accessible from within, the dangerous area, and it must be positioned so that the dangerous area may be observed by the switch operator during the reset operation.

### 3.5.2 Muting Devices

The user is required by OSHA and ANSI to arrange, install, and operate the safety system so as to protect personnel and minimize the possibility of defeating the safeguard.

Mute devices must meet a 3-second simultaneity requirement to activate muting; that is, devices in a pair must be activated within 3 seconds of one another.

#### General Muting Device Requirements

The muting devices (typically sensors or switches) must, at a minimum, comply with the following requirements:

1. There must be a minimum of two independent hard-wired muting devices.
2. The muting devices must either both have normally open contacts; or one device with a PNP output and one device with a NPN output, both of which must fulfill the input requirements listed in the Specifications (Section 2). These contacts must close when the switch is actuated, and must open (or not conduct) when the switch is not actuated or in a power OFF condition.
3. The activation of the inputs to the muting function must be from separate sources. These sources must be mounted separately in order to prevent an unsafe muting condition resulting from misadjustment, misalignment, or a single common mode failure. (For example, physical damage to the mounting surface could cause both muting devices to be knocked out of alignment, resulting in false muting input signals.) Only one of these sources may pass through, or be affected by, a programmable logic controller or similar device.
4. The muting devices must be installed so that they can not be easily defeated or bypassed.
5. The muting devices must be mounted so that their physical position and alignment can not be easily changed.
6. It must not be possible for environmental conditions to initiate a mute condition (e.g., extreme airborne contamination).
7. The muting devices must not be set to use any delay or other timing functions (unless such functions are accomplished so that no single component failure prevents the removal of the hazard, subsequent machine cycles are prevented until the failure is corrected, and no hazard is created by extending the muted period).

#### Examples of Muting Sensors and Switches

**Photoelectric Sensors (Opposed Mode):** Opposed-mode sensors, which initiate the muted condition when the beam path is blocked, should be configured for dark operate (DO) and have open (non-conducting) output contacts in a power OFF condition. **Both the emitter and receiver from each pair should be powered from the same source, to eliminate common mode failures.**

**Photoelectric Sensors (Polarized Retroreflective Mode):** The user must ensure that false "proxing" (activation due to shiny or reflective surfaces) is not possible. Banner "LP" sensors with linear polarization can greatly reduce or eliminate this effect.

Use a sensor configured for Light Operate (LO or N.O.) if initiating a mute when the retroreflective target or tape is detected (e.g., home position). Use a sensor configured for Dark Operate (DO or N.C.) when a blocked beam path initiates the muted condition (e.g., entry/exit). Both situations must have open (non-conducting) output contacts in a power OFF condition.

**Positive-Opening Safety Switches:** Two (or four) independent switches, each with a minimum of one closed safety contact to initiate the mute cycle, are typically used. An application using a single switch with a single actuator and two closed contacts could result in an unsafe situation.

**Inductive Proximity Sensors:** Typically, inductive proximity sensors are used to initiate a muted cycle when a metal surface is detected. Due to excessive leakage current causing false ON conditions, two-wire sensors are not to be used. Only three- or four-wire sensors that have discrete PNP, NPN, or hard-contact outputs that are separate from the input power can be used.



#### **WARNING . . . Avoid Hazardous Installations**

**Two or four independent position switches (at M1–M2 or M3–M4) must be properly adjusted or positioned so that they close only after the hazard no longer exists, and open again when the cycle is complete or the hazard is again present. If improperly adjusted or positioned, injury or death could result.**

The user has the responsibility to satisfy all local, state, and national laws, rules codes, and regulations relating to the use of safety equipment in any particular application. It is extremely important to be sure that all appropriate agency requirements have been met and that all installation and maintenance instructions contained in the appropriate manuals are followed.

**Muting Device Hookup**

The Module provides supply voltage, if required, and input connections for the muting devices. One or two pairs of muting devices (typically sensors or switches) must be used; these pairs are designated M1-M2 and M3-M4. The M1 and M3 inputs are PNP (sourcing). The M2 and M4 inputs are NPN (sinking). Also available are terminals to supply power (+24V dc) to the muting devices.

The current draw of all devices must not exceed 500 mA.

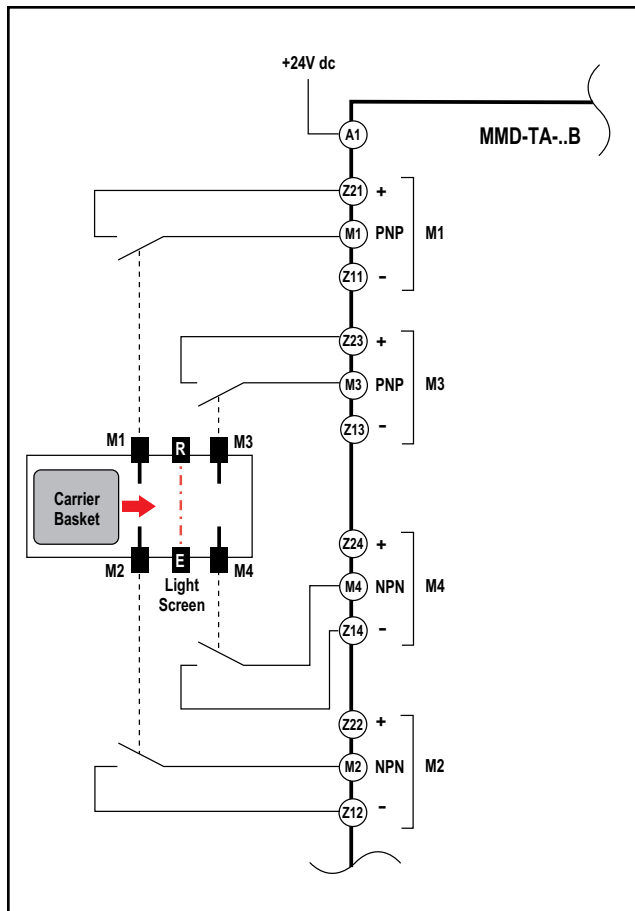

Figure 3-7. Four Limit Switches as M1, M2, M3, and M4

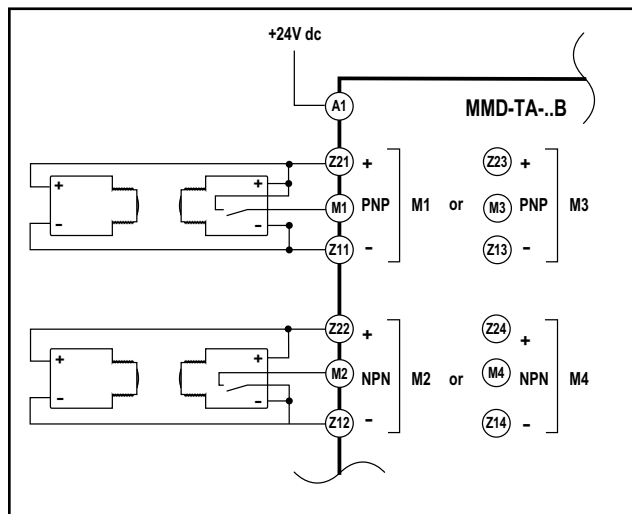

Figure 3-8. Relay (hard contact) output sensors

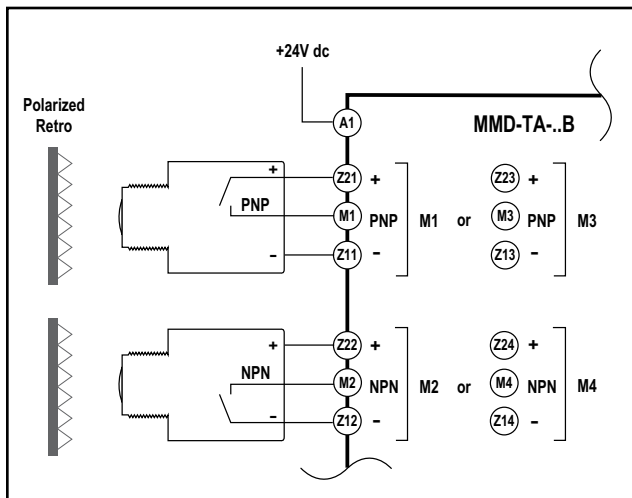

Figure 3-9. Two (or four) sensors using semiconductor outputs

### 3.5.3 Mute Lamp Output (ML)

The Mute Lamp output provides for the visible indication that the safety device's safeguarding function is muted. This indication must be readily observable. Failure of this indication should be detectable and prevent the safeguard from being muted, or the operation of the indicator should be verified at suitable intervals (see Section 1.13). The Mute Lamp output also flashes to indicate an Override condition (see Section 1.16).

The Module can be configured for a monitored or non-monitored mute lamp. It is the user's responsibility to make sure that each application meets local regulations. If the installation is governed by UL regulations, the mute lamp must be monitored (SW7 = OFF, banks A and B). This output may also be used as an input to control logic (e.g., a PLC) if "non-monitored" is selected (SW7 = ON, banks A and B). The current draw of the mute lamp must not exceed 360 mA. See Figure 3-10.

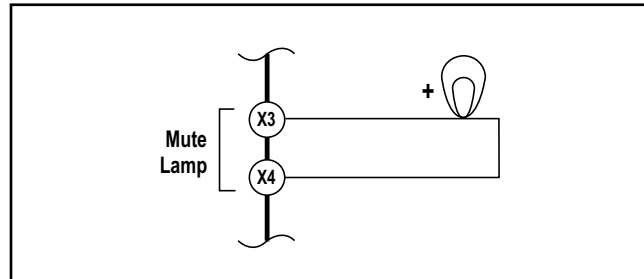

Figure 3-10. Mute Lamp output hookup

### 3.5.4 Auxiliary Output (AUX)

**Model MMD-TA-11B:** The non-safety-related output on this model is a 24V ac/dc, 250 mA normally-closed relay contact. See Output Specifications on page 9. See Figure 3-11a.

**Model MMD-TA-12B:** A non-safety-related PNP output is available at terminals Z3–Z4. This monitoring output is for light-duty, non-safety-related control functions, such as an input to a programmable logic controller (PLC). This output follows the OSSD outputs. Maximum current draw of the AUX output is 250 mA. See Figure 3-11b.

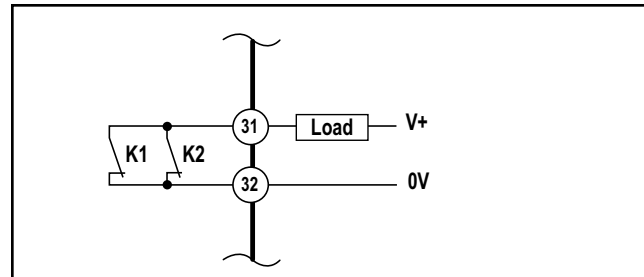

Figure 3-11a. AUX output hookup – MMD-TA-11B

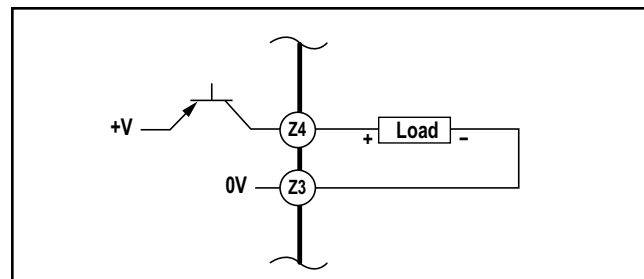

Figure 3-11b. AUX output hookup – MMD-TA-12B

### 3.5.5 Override Switch Hookup

The Module provides connection terminals for the Override switches (see Figure 3-12). See Section 1.16 and the warning below before connecting switches.



#### WARNING . . . Limit Use of Override Function

The Override function is not for machine setup or production; it is to be used only to clear the primary safeguard if material becomes "stuck," preventing its reset. When Override is used, it is the user's responsibility to install and use it according to current standards. In addition, the requirements listed in standards ANSI NFPA 79 and IEC/EN 60204-1 must be satisfied.

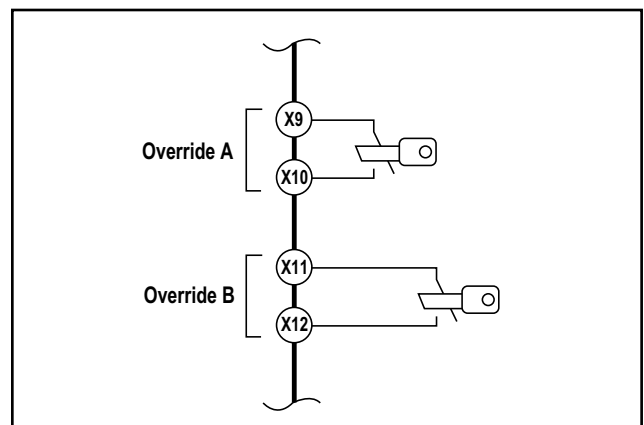

Figure 3-12. Override switch hookup

### 3.5.6 SSI and MSSI Interfacing

The Safety Stop Interface (SSI) provides easy integration of safeguards. This interface consists of two input channels (A and B), which are compatible with Banner Engineering safety devices that have solid-state OSSD outputs or other devices with sourcing +24V dc outputs. SSI is also compatible with devices that have normally open hard contacts or relay outputs (voltage-free).

The Muteable Safety Stop Interface (MSSI) input is a specialized SSI that can be muted during the non-hazardous portion of the machine cycle.

The input channels (A and B) must meet a simultaneity requirement of 3.0 seconds upon closing and opening. A mismatch of more than 3.0 seconds will result in a lockout. A lockout that is due to a failure to meet simultaneity requirements can only be cleared by:

1. Cycling the MSSI (or the SSI, depending on which failed) with simultaneity being met, and then
2. If the Module is configured for Manual Reset, performing a reset routine (see Section 1.3).

The MSSI and the SSI can be interfaced with devices with solid-state OSSD outputs, safety interlocking switches, E-stop buttons, rope/cable pull devices, and other machine control devices that switch +24Vdc. To be interfaced with a safety mat, a safety mat controller must be connected between the mat and the interface (see Figure 3-22).

NOTE: **If the SSI is not to be used**, the input channels must be jumpered. See Section 3.4.



#### **WARNING . . . Emergency Stop Functions**

**Do not connect any Emergency Stop devices to the MSSI input; do not mute or bypass any Emergency Stop device.** ANSI NFPA79 and IEC/EN 60204-1 require that the Emergency Stop function remain active at all times. **Muting or bypassing the safety outputs will render the Emergency Stop function ineffective.**

#### 3.5.6.1 Safety Circuit Integrity and ISO 13849-1 (EN954-1)

##### Safety Circuit Principles

Safety circuits involve the safety-related functions of a machine that minimize the level of risk of harm. These safety-related functions can prevent initiation, or they can stop or remove a hazard. The failure of a safety-related function or its associated safety circuit usually results in an increased risk of harm.

The integrity of a safety circuit depends on several factors, including fault tolerance, risk reduction, reliable and well-trying components, well-trying safety principles, and other design considerations.

Depending on the level of risk associated with the machine or its operation, an appropriate level of safety circuit performance (i.e., integrity) must be incorporated into the design. Standards that detail safety performance levels include ANSI/RIA R15.06 Industrial Robots, ANSI B11 Machine Tools, OSHA 29CFR1910.217 Mechanical Power Presses, and ISO 13849-1 (EN954-1) Safety-Related Parts of a Control System.

##### Safety Circuit Integrity Levels

Safety circuits in International and European standards have been segmented into categories, depending on their ability to maintain their integrity in the event of a failure. The most recognized standard that details safety circuit integrity levels is ISO 13849-1 (EN954-1), which establishes five levels: Categories B, 1, 2, 3, and the most stringent, Category 4.

In the United States, the typical level of safety circuit integrity has been called "control reliability." Control reliability typically incorporates redundant control and self-checking circuitry and has been loosely equated to ISO 13849-1 Categories 3 and 4 (see CSA Z432 and ANSI B11.TR4).

If the requirements described by ISO 13849-1 (EN954-1) are to be implemented, a risk assessment must first be performed to determine the appropriate category, in order to ensure that the expected risk reduction is achieved. This risk assessment must also take into account national regulations, such as U.S. control reliability or European "C" level standards, to ensure that the minimum level of performance that has been mandated is complied with.

##### Fault Exclusion

An important concept within the category requirements of ISO 13849-1 (EN954-1) is the "probability of the occurrence of the failure," which can be decreased using a technique termed "fault exclusion." The rationale assumes that the possibility of certain well-defined failure(s) can be reduced to a point where the resulting fault(s) can be, for the most part, disregarded—that is, "excluded."

Fault exclusion is a tool a designer can use during the development of the safety-related part of the control system and the risk assessment process. Fault exclusion allows the designer to design out the possibility of various failures and justify it through the risk assessment process to meet the intent requirements of Category 2, 3 or 4. See ISO 13849-1/-2 for further information.



#### **WARNING . . . SSI and MSSI Safety Categories**

The level of safety circuit integrity can be greatly impacted by the design and installation of the safety devices and the means of interfacing of those devices. **A risk assessment must be performed to determine the appropriate safety circuit integrity level or safety category as described by ISO 13849-1 (EN 954-1) to ensure that the expected risk reduction is achieved and that all relevant regulations are complied with.**



### 3.5.6.2 Generic SSI and MSSI Hookups

To fully understand category requirements, refer to standard ISO 13849-1 (EN954-1). The following is general in nature and is intended to provide only basic guidance. Each guarding application has its unique set of requirements; it is the user's responsibility to ensure that all local, state, and national laws, rules, codes, and regulations are satisfied.

In addition to the use of well-tried, tested, and robust components, and generally accepted principles (including fault exclusion), the safety function depends on the use of safety-rated devices. These devices are specially designed to reduce the probability of failing to an unsafe condition, and typically are third-party certified to a recognized safety standard.

#### Category 2

To meet the requirements of a category 2 application, any device connected to the SSI and MSSI inputs must meet certain criteria. For example, a "type 2" light screen (curtain) that meets IEC 61496-1/-2 is a device that meets category 2 requirements.

A category 2 safety function must be tested/checked at suitable intervals, the frequency determined by the application's risk assessment. *It should be noted that a single fault may cause the loss of the safety function.*

The principle of fault exclusion must be incorporated into the design and installation to either eliminate, or reduce to an acceptable (minimal) level of risk, the possibility of undetected faults or failures that can result in the loss of the safety function.

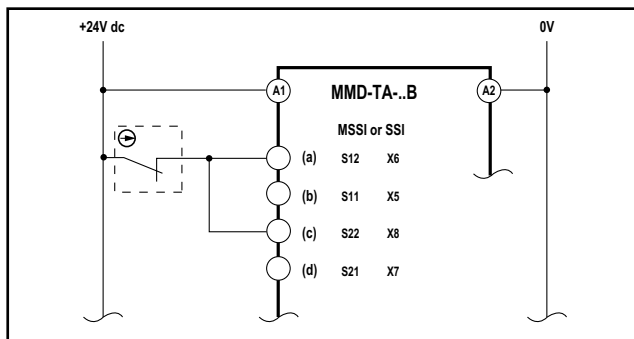

Figure 3-13a. MSSI and SSI Category 2 interfacing: positive-opening switch

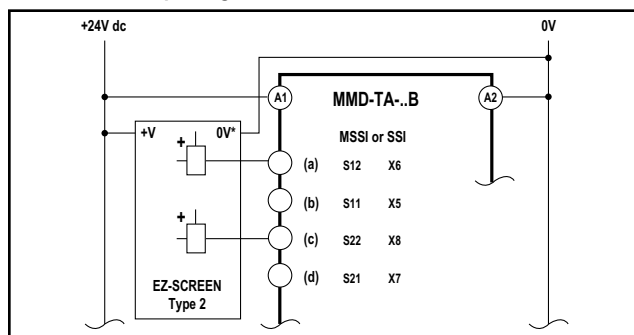

Figure 3-13b. MSSI and SSI Category 2 interfacing: Category 2 safeguarding device (e.g., EZ-SCREEN "Type 2" or AOPD type 2 per IEC 61496-1/-2)

#### Category 3

To meet the requirements of a category 3 application, any device connected to the SSI and MSSI inputs must meet certain criteria. For example, a "type 3" laser area scanner that meets IEC 61496-1/-3 is a device that meets category 3 requirements.

In a category 3 safety application, a single fault must not cause the loss of the safety function. This is usually accomplished by using redundant safety inputs or outputs from the safety-rated device. Faults should be detected whenever reasonably practicable, although a short circuit between input channels or safety outputs may not be detected. It should be noted that an accumulation of faults may cause the loss of the safety function.

The principle of fault exclusion must be incorporated into the design and installation to either eliminate, or reduce to an acceptable (minimal) level of risk, the possibility of undetected faults or catastrophic failures that could result in the loss of the safety function.

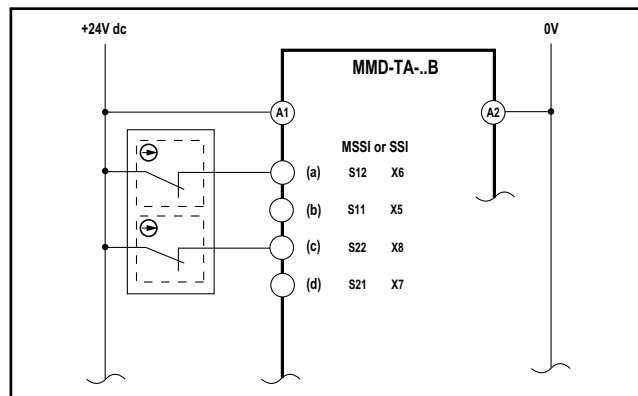

Figure 3-14a. MSSI and SSI Category 3 interfacing: two positive-opening switches per single guard

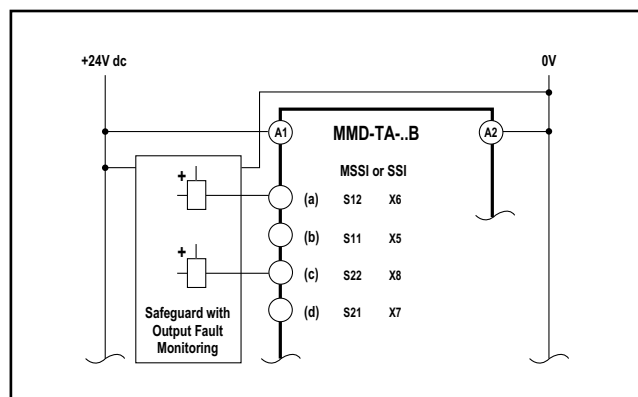

Figure 3-14b. MSSI and SSI Category 3 interfacing: category 3 safeguarding device with output fault monitoring (e.g., type 3 area scanner AOPDDR per IEC 61496-1/-3)

## Category 4

To ensure a category 4 application, any device connected to the SSI and MSSi inputs must meet certain criteria. For example, a “type 4” safety light screen (curtain) that meets IEC 61496-1/-2 is a device that meets category 4 requirements.

In a category 4 application, a single fault must not cause the loss of the safety function. The fault must be detected at or before the next demand of the safety function, and an accumulation of faults also must not cause the loss of the safety function.

This is usually accomplished by the use of redundant safety inputs or outputs from the safety-rated device that are monitored to detect certain faults. These faults include:

- Increased response time
- Prevention of one or more safety outputs (OSSDs) going to the OFF-state
- A short circuit between channels

NOTE: Solid-state safety outputs, such as those from EZ-SCREEN Type 4 safety light screens, typically achieve this level of fault tolerance by self-monitoring a pulsing of the outputs. Safety devices with hard-contact or relay outputs must be connected in a “4-wire” method as shown in Figure 3-15c.

The principle of fault exclusion must be incorporated into the design and installation to either eliminate, or reduce to an acceptable (minimal) level of risk, the possibility of catastrophic failures/faults that could result in the loss of the safety function.

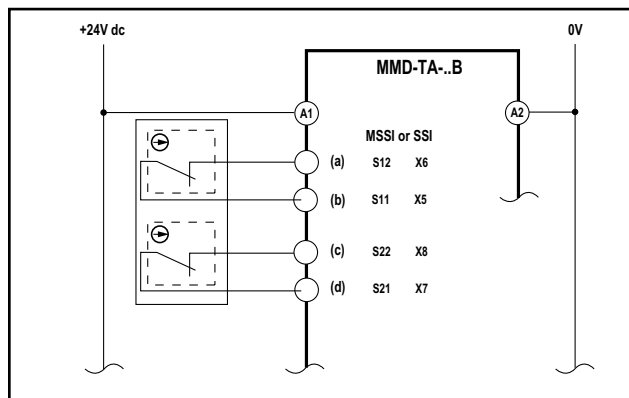

Figure 3-15a. MSSi and SSI Category 4 interfacing: two positive-opening switches per single guard

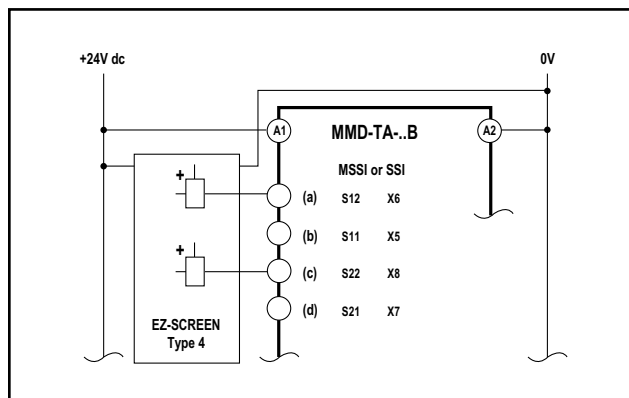

Figure 3-15b. MSSi and SSI Category 4 interfacing: category 4 safeguarding device with output fault monitoring (e.g., EZ-SCREEN or AOPD Type 4 per IEC 61496-1/-2)

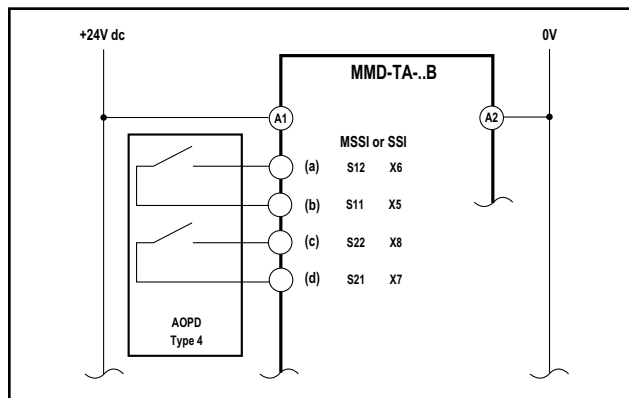

Figure 3-15c. MSSi and SSI Category 4 interfacing: category 4 safeguarding device with relay outputs (e.g., MINI-SCREEN or AOPD Type 4 per IEC 61496-1/-2)

### 3.5.6.3 SSI Emergency Stop Switch Device Hookup

#### Emergency Stop Push Button Switches

As shown in Figures 3-16, 3-17 and 3-18, the E-stop switch must provide one or two contacts for safety which are closed when the switch is armed. Once activated, the E-stop switch must open all its safety-rated contacts, and must require a deliberate action (such as twisting, pulling, or unlocking) to return to the closed-contact, armed position. The switch should be a “positive-opening” (or direct-opening) type, as described by IEC 60947-5-1. A mechanical force applied to such a button (or switch) is transmitted directly to the contacts, forcing them open. This ensures that the switch contacts will open whenever the switch is activated.

Standards ANSI NFPA 79, IEC/EN 60204-1, and ISO 13850 specify additional emergency stop switch device requirements, including the following:

- Emergency Stop push buttons shall be located at each operator control station and at other operating stations where emergency shutdown is required.
- Stop and Emergency Stop push buttons shall be continuously operable and readily accessible from all control and operating stations where located. **Do not connect E-stop buttons to the MSSI.**
- Actuators of Emergency Stop devices shall be colored Red. The background immediately around the device actuator shall be colored Yellow. The actuator of a push-button-operated device shall be of the palm or mushroom-head type.
- The Emergency Stop actuator shall be a self-latching type.

NOTE: Some applications may have additional requirements. The user must comply with all relevant regulations.

#### Safety Circuit Integrity Levels and Emergency Stop functions

As part of the required risk assessment for the machine, ANSI NFPA 79 and IEC/EN 60204-1 state that the safety performance (integrity) must reduce the risk from identified hazards as determined by the risk assessment. See Sections 3.5.6.1 and 3.5.6.2 for guidance if the requirements as described by ISO 13849-1 (EN954-1) are to be implemented.

In addition to the requirements stated above, the design and the installation of the emergency stop device (e.g., switch, button, or rope-pull) must be such that **the possibility of a catastrophic failure of the device resulting in the loss of the safety function must be excluded** (designed out). Per ISO 13849-2, electromechanical devices that have contacts designed in accordance to IEC 60947-5-1 Annex K and that are installed per manufacturer’s instructions are expected to open when the emergency stop device is actuated.



#### WARNING . . . Emergency Stop Functions

Do not connect any device to the MSSI Input that is used for an emergency stop function. Never mute or bypass any emergency stop device (e.g., a button or rope pull). ANSI NFPA 79 and IEC/EN 60204-1 require that the emergency stop function remain active at all times.

**Muting or bypassing the safety outputs will render the Emergency Stop function ineffective.**



#### WARNING . . . Reset Routine Required

U.S. and international standards require that a reset routine be performed after returning the E-stop switch to its closed-contact position (when arming the E-stop switch). When automatic reset is used, an alternate means must be established to require a reset routine, after the E-stop switch is armed. **Allowing the machine to restart as soon as the E-stop switch is armed creates an unsafe condition which could result in serious injury or death.**

#### Category 2

A single-channel emergency stop application typically provides a category 2 level of circuit performance, because a short circuit could cause the loss of the safety function. The principle of fault exclusion must be incorporated into the design and installation to either eliminate, or reduce to an acceptable (minimal) level of risk, the possibility of undetected faults or failures that can result in the loss of the safety function.

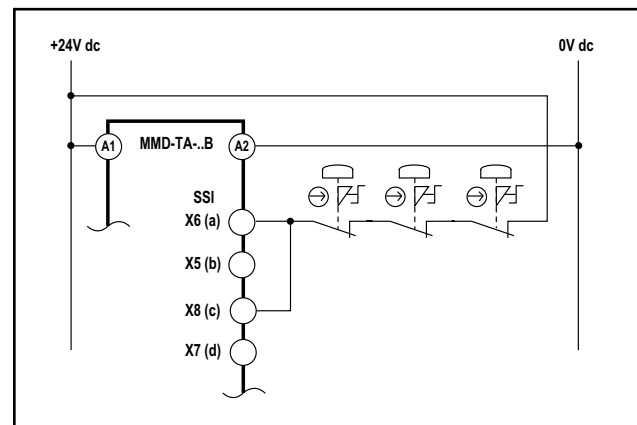

Figure 3-16. SSI Category 2 interfacing: positive-opening E-stop switch(es)

**Category 3**

A dual-channel hookup switching +24V dc is typically a category 3 application, because a single failure does not result in a loss of safety. Loss of the switching action in one channel is detected by the actuation of the E-stop button, the opening of the second channel, and the monitoring function of the SSI inputs. However, a short circuit between input channels or safety outputs may not be detected. It should be noted that an accumulation of faults may cause the loss of the safety function.

The principle of fault exclusion must be incorporated into the design and installation to either eliminate, or reduce to an acceptable (minimal) level of risk, the possibility of undetected faults or catastrophic failures that could result in the loss of the safety function.

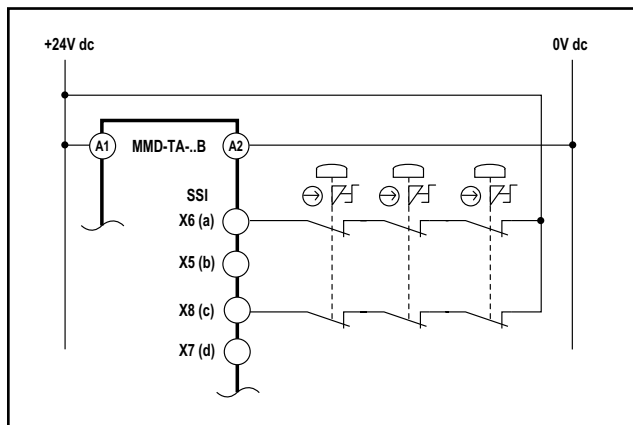

Figure 3-17. SSI Category 3 interfacing: positive-opening E-stop switch(es)

**Category 4**

The self-monitoring SSI inputs can be interfaced to achieve a category 4 application. The principle of fault exclusion must be incorporated into the design and installation to either eliminate, or reduce to an acceptable (minimal) level of risk, the possibility of catastrophic failures or faults that could result in the loss of the safety function.

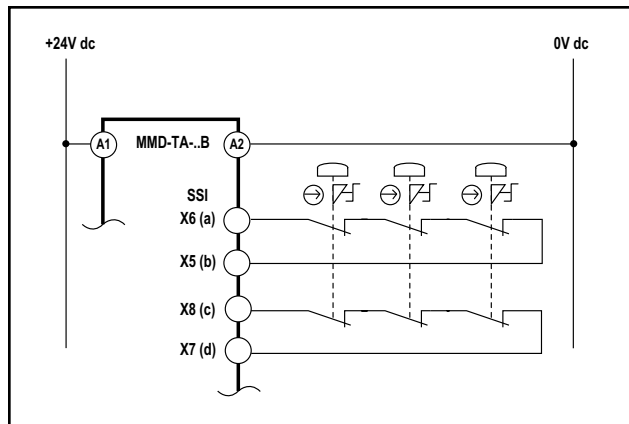

Figure 3-18. SSI Category 4 interfacing: positive-opening E-stop switch(es)

**WARNING . . . Multiple E-Stop Switches**

Whenever two or more Emergency Stop switches are connected to the same Module:

- **Contacts of the corresponding pole of each switch must be connected together in series. Never connect the contacts of multiple Emergency Stop switches in parallel to one Module.** Such a parallel connection defeats the switch contact monitoring ability of the Module and creates an unsafe condition which could result in serious injury or death.
- **Each switch must be individually actuated (engaged), then re-armed and the Module reset.** This allows the controller to check each switch and its wiring to detect faults. **Failure to test each switch individually in this manner could result in undetected faults and create an unsafe condition which could result in serious injury or death.** This check must be performed during periodic checkouts (see Section 6).

### 3.5.6.4 SSI/MSSI Interlocked Guard or Gate Hookup

The SSI (or MSSI) may be used to monitor electrically interlocked safety guards or gates.

#### Safety Circuit Integrity Levels

Requirements vary widely for the level of control reliability or safety category per ISO 13849-1 (EN954-1) in the application of interlocked guards. While Banner Engineering always recommends the highest level of safety in any application, it is the responsibility of the user to safely install, operate and maintain each safety system and comply with all relevant laws and regulations.

The safety performance (integrity) must reduce the risk from identified hazards as determined by the machine's risk assessment. See Sections 3.5.6.1 and 3.5.6.2 for guidance if the requirements as described by ISO 13849-1 (EN954-1) are to be implemented.

In addition to the requirements stated in this section, the design and installation of the interlocking device should comply with ANSI B11.19 or ISO 14119.

#### Safety Interlocking Switch Requirements

The following general requirements and considerations apply to the installation of interlocked guards and gates for the purpose of safeguarding. In addition, refer to the relevant regulations to be sure to comply with all necessary requirements.

Hazards guarded by the interlocked guard must be prevented from operating until the guard is closed; a stop command must be issued to the guarded machine if the guard opens while the hazard is present. Closing the guard must not, by itself, initiate hazardous motion; a separate procedure must be required to initiate the motion. The safety switches must not be used as a mechanical or end-of-travel stop.

The guard must be located an adequate distance from the danger zone (so that the hazard has time to stop before the guard is opened sufficiently to provide access to the hazard), and it must open either laterally or away from the hazard, not into the safeguarded area. The guard also should not be able to close by itself and activate the interlocking circuitry. In addition, the installation must prevent personnel from reaching over, under, around or through the guard to the hazard. Any openings in the guard must not allow access to the hazard (see OSHA 29CFR1910.217 Table O-10, ANSI B11.19, EN 294, ISO 14120/EN953 or the appropriate standard). The guard must be strong enough and designed to protect personnel and contain hazards within the guarded area, which may be ejected, dropped or emitted by the machine.

The safety interlocking switches and actuators used with the Muting Module must be designed and installed so that they cannot be easily defeated. They must be mounted securely, so that their physical position can not shift, using reliable fasteners that require a tool to remove them.

#### Positive-Opening Safety Interlocking Switches

Safety interlock switches used with the Muting Module must satisfy several requirements. Each switch must provide electrically isolated contacts: at minimum, one normally closed (N.C.) contact from each individually mounted switch.

The contacts must be of "positive-opening" (direct-opening) design, as described by IEC 60947-5-1, with one or more normally closed contacts rated for safety. Positive-opening operation causes the switch to be forced open, without the use of springs, when the switch actuator is disengaged or moved from its home position (see the Banner Safety Catalog for examples). In addition, the switches must be mounted in a "positive mode," to move/disengage the actuator from its home position and open the normally closed contact, when the guard opens.

#### Monitoring Series-Connected Safety Interlocking Switches

When monitoring two individually mounted safety switches (as shown in Figure 3-21), a faulty switch will be detected if it fails to switch as the guard opens. In this case, the Module will de-energize its safety outputs (OSSDs) and disable its reset function until the input requirements are met (i.e., the faulty switch is replaced). However, when a series of safety interlocking switches is monitored by a single Module, the failure of one switch in the system may be masked or not be detected at all (refer to Figures 3-19 and 3-20).

Series-connected interlock switch circuits may not meet OSHA Control Reliability or ISO 13849 (EN 954-1) safety category 4 requirements because of the potential of an inappropriate reset or a potential loss of the safety stop signal. This is due to the typical inability to fault exclude the failure of the safety interlock switch. A multiple connection of this type should not be used in applications where loss of the safety stop signal or an inappropriate reset can lead to serious injury or death. The following two scenarios assume two positive-opening safety switches on each guard:

1. **Masking of a failure.** If a guard is opened but a switch fails to open, the redundant safety switch will open and cause the Module to de-energize its outputs. If the faulty guard is then closed, both Module input channels also close, but because one channel did not open, the Module will not reset. However, if the faulty switch is not replaced and a second "good" guard is cycled, opening and then closing both of the Module's input channels, the Module considers the failure to be corrected. With the input requirements apparently satisfied, the Module allows a reset. This system is no longer redundant and, if the second switch fails, may result in an unsafe condition (i.e., the accumulation of faults results in the loss of the safety function).
2. **Non-detection of a failure.** If a good guard is opened, the Safety Module de-energizes its outputs (a normal response). But if a faulty guard is then opened and closed before the good guard is re-closed, the failure on the faulty guard is not detected. This system also is no longer redundant and may result in a loss of safety if the second safety switch fails to switch when needed.

The systems in either scenario do not inherently comply with the safety standard requirements of detecting single faults and preventing the next cycle. In multiple-guard systems using series-connected safety switches, it is important to periodically check the functional integrity of each interlocked guard individually. **Operators, maintenance personnel, and others associated with the operation of the machine must be trained to recognize such failures and be instructed to correct them immediately.**

Open and close each safeguard separately while verifying that the Module outputs operate correctly throughout the check procedure. Follow each safeguard closure with a manual reset, if needed. If a contact set fails, the Module will not enable its reset function. If the Module does not reset, a switch may have failed; that switch must be immediately replaced.

This check must be performed and all faults must be cleared, at a minimum, during periodic checkouts. **If the application can not exclude these types of failures and such a failure could result in serious injury or death, then the series connection of safety switches must not be used.**

**Category 2**

A single-channel interlocked guard application typically provides a category 2 level of circuit performance, because a short circuit could cause the loss of the safety function. The principle of fault exclusion must be incorporated into the design and installation to either eliminate, or reduce to an acceptable (minimal) level of risk, the possibility of undetected faults or failures that can result in the loss of the safety function.

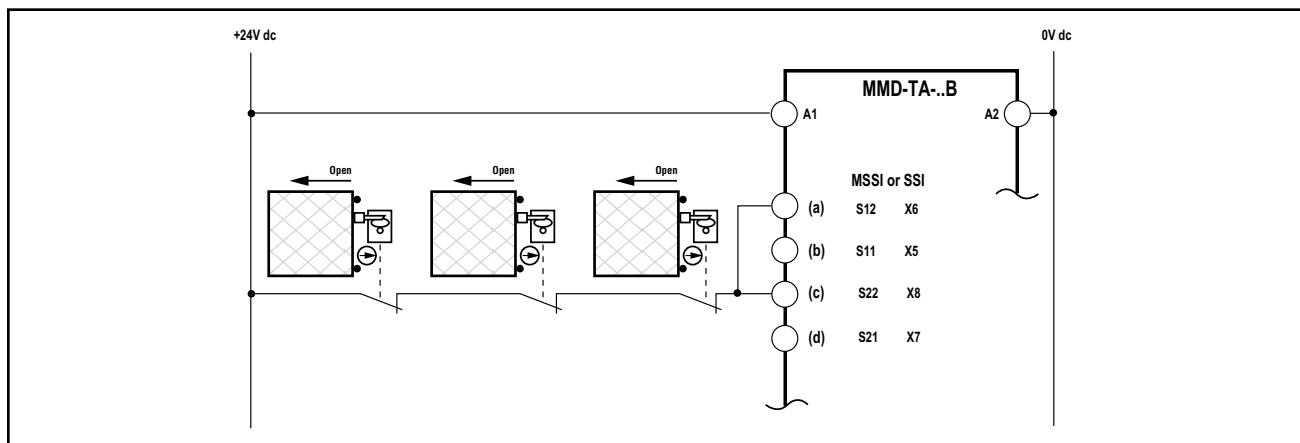

Figure 3-19. MSSl or SSl Category 2 interfacing: positive opening



### Category 3

A dual-channel hookup switching +24V dc is typically a category 3 application, because a single failure does not result in a loss of safety. Loss of the switching action in one channel is detected by the actuation of opening and closing the guard, allowing the monitoring function of the MSSI or SSI inputs to detect the discrepancy between the channels. However, a short circuit between input channels or safety outputs may not be detected. It should be noted that an accumulation of faults may cause the loss of the safety function.

The principle of fault exclusion must be incorporated into the design and installation to either eliminate, or reduce to an acceptable (minimal) level of risk, the possibility of undetected faults or catastrophic failures that could result in the loss of the safety function.

### Category 4

The self-monitoring MSSI or SSI inputs can be interfaced to achieve a category 4 application. The principle of fault exclusion must be incorporated into the design and installation to either eliminate, or reduce to an acceptable (minimal) level of risk, the possibility of catastrophic failures/faults that could result in the loss of the safety function.

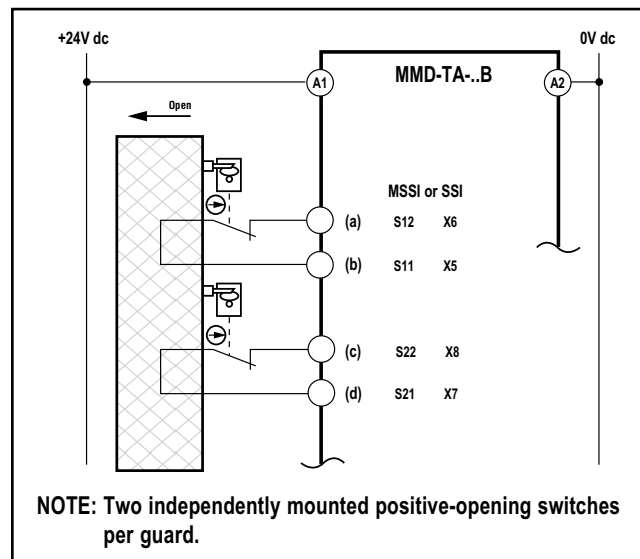

Figure 3-21. SSI Category 4 interfacing: positive-opening interlocking switch(es)

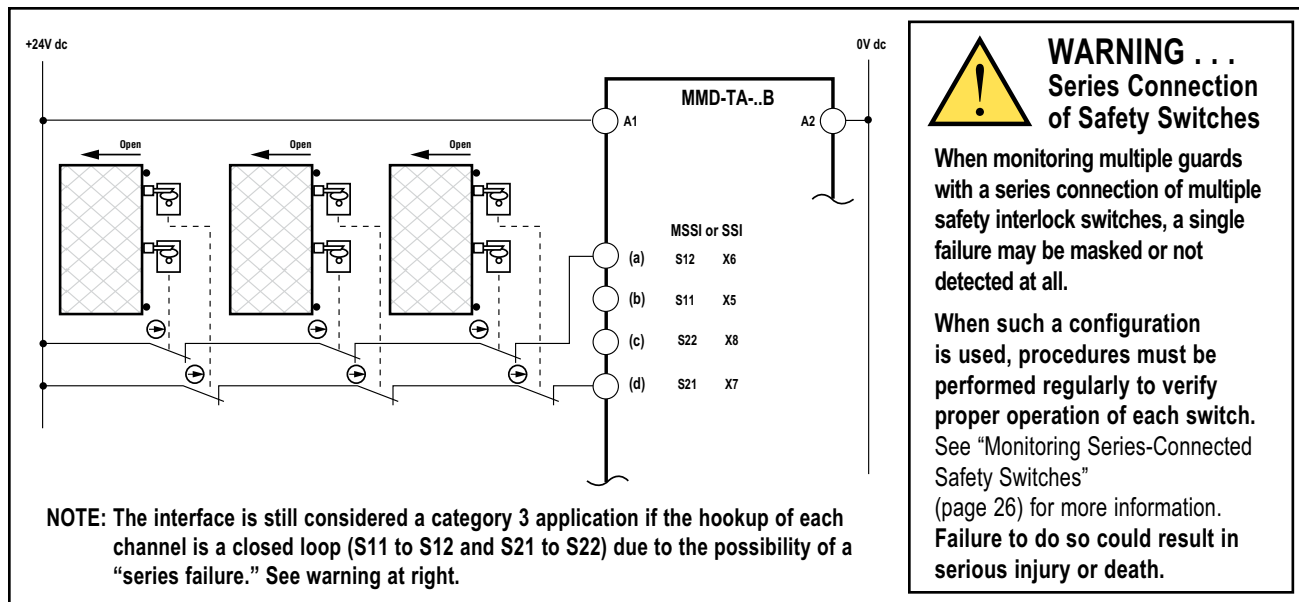

Figure 3-20. MSSI or SSI Category 3 interfacing: Positive-opening Interlocking switch(es)

### 3.5.6.5 SSI Supplemental Safety System Hookup

A variety of safety systems can be interfaced with the MSSl and the SSI. Each safety application has a unique set of application requirements. The user is responsible to ensure proper installation and use, and that all relevant standards and regulations are complied with. Figure 3-22 shows a generic example of the flexibility of the SSI.

**Entry/Exit Application with a Multiple-Beam Safety System (Muted) and a Safety Mat System:** see Appendix B for more

information. This application is widely used in a variety of situations, including manufacturing cells, robotic cells, palletizers, and de-stackers. One of the many requirements of this muting application is that it must not be possible for personnel to walk in front of, behind, or next to the muted object (e.g., the carrier basket) without being detected and stopping the hazardous motion.

Figure 3-22 shows how supplemental safeguarding (such as a safety mat system or horizontal safety light screen) can be interfaced to prevent personnel from entering the hazardous area during a mute condition.

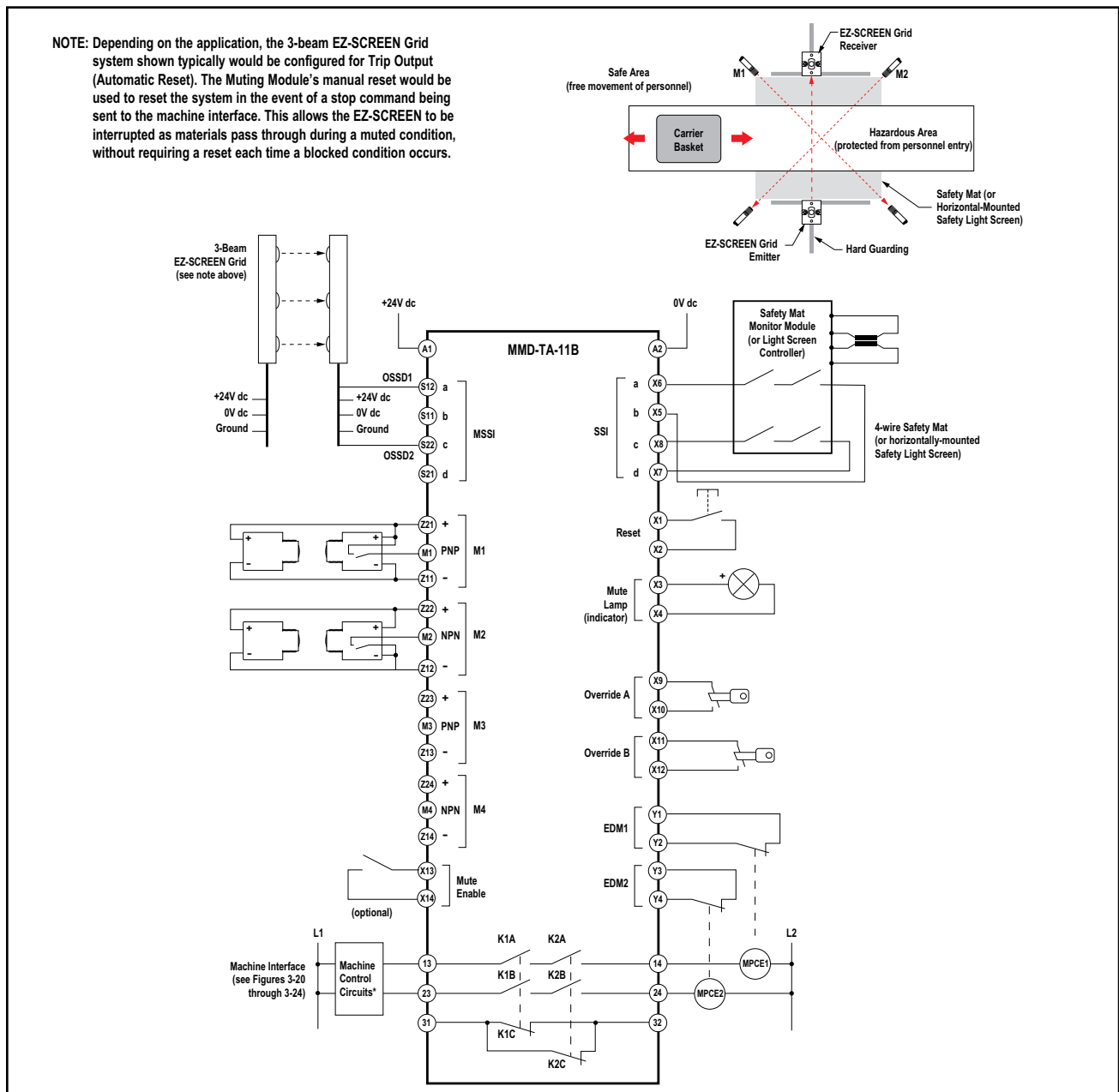

Figure 3-22. Interfacing supplemental safeguarding to prevent personnel from entering the hazardous area during the mute

### 3.6 Machine Interface – Initial Hookup and Checkout

Model **MMD-TA-11B** provides two normally open safety relay output contacts (13–14 and 23–24) to hook up external MPCE1 and MPCE2 (see Figures 3-27 and 3-28).

Model **MMD-TA-12B** provides two PNP solid-state safety outputs, OSSD1 and OSSD2 (Y5–Y6 and Y7–Y8) see Figures 3-24, 3-25, and 3-26.

For monitoring external devices (both models), normally closed contacts of these devices must be hooked up to EDM #1 (Y1–Y2) and EDM #2 (Y3–Y4).

Before proceeding, ensure that power has been removed from machine or ensure that power is not available to the machine controls or actuators, and ensure that the machine control (MPCEs) are not connected to or controlled by the OSSD or relay safety outputs at this time. Permanent connections will be made after Module initial checkout (see Section 3.7).

#### Verifying System Operation

The initial checkout procedure must be performed by a Qualified Person (see Warning, page 12). It must be performed only after configuring the Module and after properly installing and configuring the safety systems connected to its MSSSI and the SSI inputs (per Section 3).

The initial checkout procedure is performed on two occasions:

- To ensure proper installation when the System is first installed, and
- To ensure proper System function whenever any maintenance or modification is performed on the System or on the machinery being guarded by the System. (See Section 6.1 for a schedule of required checkouts.)

For the initial checkout, the Muting Module and associated safety systems must be checked without power being available to the guarded machine. Final interface connections to the guarded machine cannot take place until these systems have been checked out.

Verify that:

- Power has been removed from (or is not available to) the guarded machine, its controls or actuators;
- The machine control circuit is not connected to the OSSD outputs at this time (permanent connections will be made following this initial checkout), and that the OSSD leads are isolated (i.e. not shorted together, not shorted to power or ground);
- EDM has been configured for No Monitoring (SW4 = OFF or 2 CH) and EDM #1 (Y1–Y2) and EDM #2 (Y3–Y4) are jumpered;
- Other than EDM and Mute Enable, verify proper Module DIP switch configuration for your application; and

- All input connections have been made per appropriate sections for the Mute Input Devices (M1–M4), SSI, MSSSI, Manual Reset Switch, Mute Lamp, AUX Output, and Override Input.

This will allow the Muting Module and the associated safety systems to be checked out, by themselves, before permanent connections are made to the guarded machine.

### 3.6.1 Temporary Power and Initial Checkout

1. Connection of system DC power is at terminals A1 (+24V dc) and A2 (0V dc), see Section 3.4 and Figure 3-4. All wiring must comply with NEC and local wiring codes.
2. Leaving power to the guarded machine OFF, power up the Module and the safety systems connected to the MSSSI and the SSI inputs.
3. Perform system checkout procedures for the external safety systems connected to the MSSSI and SSI inputs as described by the appropriate manuals. Do not proceed further until all checkout procedures are completed successfully and all problems have been corrected.
4. Verify that the external safety systems are providing a Green/Go signal to the MSSSI and SSI inputs (i.e., Banner OSSD sourcing signal or a closed contact connected to the “Signal” pin of each interface). Verify that the green Channel indicators are ON.

NOTE: If the SSI is not to be used, terminals X5–X6 and X7–X8 must be jumpered (factory default). Do not short Channel A to Channel B. See Section 3.5.6.

5. **Auto Reset Configuration:** Verify that the Green status LED is ON, indicating that the OSSD outputs are ON, and that a “—” appears on the Diagnostic Display. If not, or if the Red status indicator begins to flash at any time, refer to Section 5 for troubleshooting information.

**Manual Reset Configuration:** Verify that the Yellow status LED is flashing to indicate that a reset is being requested, and that a “—” appears on the Diagnostic Display. If not, or if the Red status indicator begins to flash at any time, refer to Section 5 for troubleshooting information.

Perform a manual reset by closing the Reset input for at least 1/4 second, but not longer than 2 seconds, and then reopening the contact. Verify that the Green status indicator comes on steady. The Module OSSD outputs should be ON at this time.

6. Cycle the MSSSI and the SSI (if used) individually and ensure that the Green status indicator goes OFF, and that a reset is possible after the interface is closed.

**If any of these checks fail, do not attempt to use the system until the reason for the failure(s) is identified and corrected.**

If the Muting function is not used, proceed to Section 3.7.

During the initial checkout procedure of the Muting feature, if possible, verify that the power has been removed or is otherwise not available to the machine actuators responsible for hazardous motion. At all times ensure that personnel are not exposed to any hazard.

7. Mute the System by blocking (or activating) both mute devices (typically M1 and M2) simultaneously (within 3 seconds).
  8. If used, verify that the Mute indicator comes ON. If not, check the indicator and its wiring, and check the Diagnostic Display for error codes.
  9. Generate a stop command from the safeguarding device connected to the MSSl (e.g., interrupt the defined area of a safety light screen). Verify that MSSl Channel A and B indicators go OFF, but the Green status indicator remains ON.
- NOTE: If the 30- or 60-second Backdoor Timer feature is selected, the Diagnostic Display will begin to count down in seconds. If the 30-minute Backdoor Timer feature is selected, the timer countdown is in minutes. A flashing dash will appear on the display if the Backdoor Timer is OFF (infinite).
10. Clear the Stop command (before the Backdoor Timer expires) and verify that the MSSl Channel A and B indicators come ON. Clear (deactivate) the mute devices before the Backdoor Timer expires and verify the Mute indicator goes OFF. The Green status indicator should remain ON.
  11. Verify that it is not possible for a single individual to initiate a mute condition by triggering the mute devices (for example, by blocking both photoelectric beams or actuating both switches) and being able to pass through the safeguard without being detected and without issuing a stop command to the machine. Do not expose any individual to hazard while attempting to mute the system.
  12. Verify that it is not possible for personnel to pass in front of, behind, or next to the muted object without being detected and without issuing a stop command to the machine.
  13. If one-way (directional) muting has been selected, verify that the system can not be muted by blocking (or activating) M3-M4 before M1-M2. Do not expose any individual to hazard while attempting to mute the system.

**If all checks have been verified, proceed to Section 3.7. If any of these checks fail, do not attempt to use the system until the reason for the failure(s) is identified and corrected.**

### 3.7 Permanent Hookup to the Guarded Machine

#### OSSD and EDM Connections and Electrical Interface

Supply power, the external reset switch, and other inputs (as required by each application) should be previously connected by this point. The final connections to be made are:

- Mute enable,
- EDM hookup,
- OSSD outputs,
- FSD interfacing, and
- MPCE connections.



#### WARNING . . . Shock Hazard

Always disconnect power from the Safety System and the guarded machine before making any connections or replacing any component. Use extreme caution to avoid electrical shock at all times. Serious bodily injury or death could result.



#### WARNING . . . Proper Wiring

The generalized wiring configuration shown in Figures 3-24, 3-25, 3-26, 3-27 and 3-28 are provided only to illustrate the importance of proper installation. The proper wiring of the Safety system to any particular machine is the sole responsibility of the installer and end user.

### 3.7.1 Mute Enable Hookup

The Module provides a Mute Enable input (“ME,” X13–X14) for the connection of a potential free contact (see Section 1.12). Mute Enable gives the user the ability to “frame” or create a “window of opportunity” when a mute can occur. When configured, the Mute Enable input is a contact that must be closed before the safeguard can be muted. After the safeguard is muted, opening of the Mute Enable input has no effect, but it must be re-closed before the safeguard can be muted again.

To hook up a device (sensor or PLC output) with a solid state output, see optional hookup in Figure 3-23.

If Mute Enable is not to be used, leave the factory-installed jumper between X13–X14.

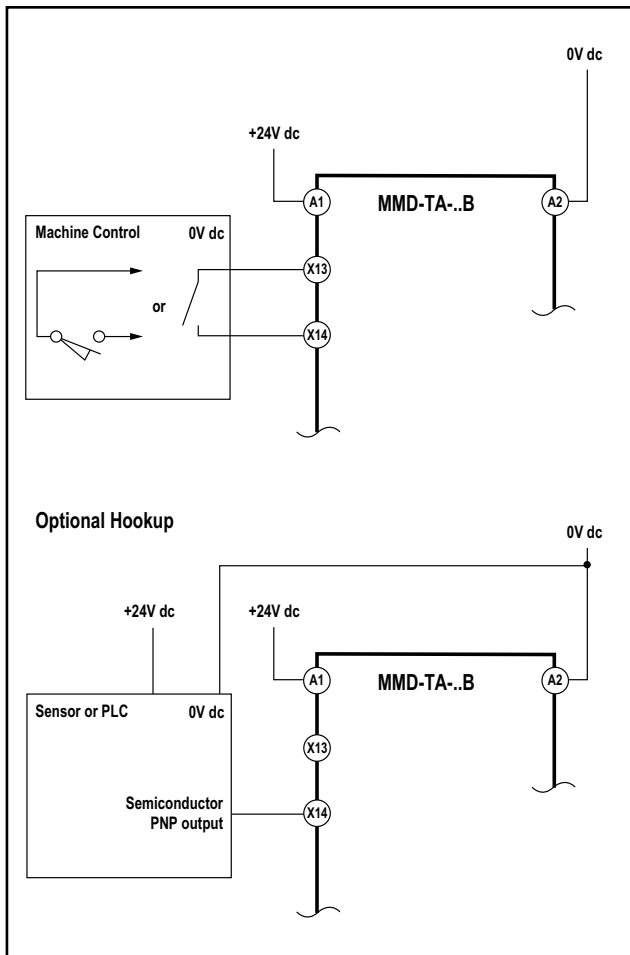

Figure 3-23. Mute Enable hookup

### 3.7.2 External Device Monitoring (EDM) Hookup

The Module provides connection terminals for the External Device Monitoring input (EDM #1—Y1–Y2 and EDM #2—Y3–Y4). External Device Monitoring must be wired in one of three configurations:

- One-Channel Monitoring — SW4 Banks A and B = ON or 1 CH (see Figures 3-26 and 3-28). NOTE: EDM #2 input must be left open.
- Two-Channel Monitoring — SW4 Banks A and B = OFF or 2 CH (see Figures 3-24, 3-25, and 3-27).
- No Monitoring — SW4 Banks A and B = OFF or 2 CH  
NOTE: Terminal Y1 of EDM #1 must be jumpered to Y3 of EDM #2.

After the initial checkout has been successfully completed, the EDM configuration that disabled the monitoring function must be properly reconfigured. The External Device Monitoring inputs then must be properly connected to the closed monitoring contacts of the MPCEs (see Section 1.10). Refer to the NOTICE Regarding MPCE Monitoring Hookup, below, and Figures 3-24, 3-25, 3-26, 3-27, and 3-28.



#### CAUTION . . . EDM Configuration

If the application does not require this function, the terminal Y1 of EDM #1 must be jumpered to Y3 of EDM #2 (see Section 3.7.2). It is the user's responsibility to ensure that this does not create a hazardous situation.

#### NOTICE Regarding External Device Monitoring Hookup

It is strongly recommended that one normally closed, forced-guided, monitoring contact of each MPCE or external device be wired in order to monitor the state of the MPCEs (as shown in Figures 3-24 to 3-28). If this is done, proper operation of the MPCEs will be verified. MPCE monitoring contacts must be used in order to maintain control reliability.

### 3.7.3 OSSD Output Connections

Both the output signal switching device (OSSD) outputs must be connected to the machine control such that the machine's safety related control system interrupts the circuit or power to the machine primary control element(s) (MPCE), resulting in a non-hazardous condition. This applies equally to the safety relays of the model **MMD-TA-11B** and the solid-state output of the model **MMD-TA-12B**.

Final switching devices (FSDs) typically accomplish this when the OSSDs go to an OFF state. See Figure 3-24.

Refer to the output specifications (Section 2) and Warning below before making OSSD connections and interfacing the Muting Module to the machine.



#### **WARNING . . . OSSD Interfacing**

To ensure proper operation, the Muting Module output parameters and machine input parameters must be considered when interfacing the Muting Module solid-state OSSD outputs to the machine inputs.

Machine control circuitry must be designed so that:

- The maximum cable resistance value between the Muting Module solid-state safety outputs and the machine inputs is not exceeded,
- The Muting Module solid-state safety output maximum OFF-state voltage does not result in an ON condition, and
- The Muting Module solid-state safety output maximum leakage current, due to the loss of 0V, will not result in an ON condition.

**Failure to properly interface the OSSD outputs to the guarded machine could result in serious bodily injury or death.**

### 3.7.4 FSD Interfacing Connections

Final switching devices (FSDs) can take many forms, though the most common are forced-guided (mechanically linked) relays or Interfacing Modules. The mechanical linkage between the contacts allow the device to be monitored by the external device monitoring circuit for certain failures.

Dependent on the application, the use of FSDs can facilitate controlling voltage and current that differs from the OSSD outputs of the Module. FSDs can also be used to control an additional number of hazards by creating multiple safety stop circuits.

#### **Safety (Protective) Stop Circuits**

A safety stop allows for an orderly cessation of motion or hazardous situation for safeguarding purposes, which results in a stop of motion and removal of power from the MPCEs (assuming this does not create additional hazards). A safety stop circuit typically comprises of a minimum of two normally open contacts from forced-guided (mechanically linked) relays, which are monitored to detect certain failures such that the loss of the safety function does not occur (i.e. external device monitoring). Such a circuit can be described as a "safe switching point."

Typically, safety stop circuits are either single channel (a series connection of at least two N.O. contacts); or dual channel (a parallel connection of two N.O. contacts). In either method, the safety function relies on the use of redundant contacts to control a single hazard, so that if one contact fails ON, the second contact will arrest the hazard and prevent the next cycle from occurring.

Interfacing safety stop circuits must be wired so that the safety function can not be suspended, overridden, or defeated, unless accomplished in a manner at the same or greater degree of safety as the machine's safety-related control system that includes the Module.

The normally open outputs from an IM-T-9A or -11A interfacing module are a series connection of redundant contacts that form safety stop circuits and can be used in either single-channel or dual-channel control methods. (See Figures 3-25 and 3-26.)



### Dual-Channel Control

Dual-channel (or two-channel) control has the ability to electrically extend the safe switching point beyond the FSD contacts. With proper monitoring (i.e., EDM), this method of interfacing is capable of detecting certain failures in the control wiring between the safety stop circuit and the MPCEs. These failures include a short-circuit of one channel to a secondary source of energy or voltage, or the loss of the switching action of one of the FSD outputs. The result could lead to the loss of redundancy or a complete loss of safety if not detected and corrected.

The possibility of a failure to the wiring increases as the physical distance between the FSD safety stop circuits and the MPCEs increase, as the length or the routing of the interconnecting wires increases, or if the FSD safety stop circuits and the MPCEs are located in different enclosures. Thus, dual-channel control with EDM monitoring should be used in any installation where the FSDs are located remotely from the MPCEs.

### Single-Channel Control

Single-channel (or one-channel) control, as mentioned, uses a series connection of FSD contacts to form a safe switching point. After this point in the machine's safety-related control system, failures can occur that would result in the loss of the safety function (e.g., a short-circuit to a secondary source of energy or voltage).

Thus, this method of interfacing should only be used in installations where FSD safety stop circuits and the MPCEs are physically located within the same control panel, adjacent to each other, and are directly connected to each other; or where the possibility of such a failure can be excluded. If this can not be achieved, then two-channel control should be used.

Methods to exclude the possibility of these failures include, but are not limited to:

- Physically separating interconnecting control wires from each other and from secondary sources of power.
- Routing interconnecting control wires in separate conduit, runs, or channels.
- Routing interconnecting control wires with low voltage or neutral that can not result in energizing the hazard.
- Locating all elements (modules, switches, devices under control, etc.) within the same control panel, adjacent to each other, and directly connected with short wires.
- Properly installing multi-conductor cabling and multiple wires that pass through strain-relief fittings. Over-tightening of a strain-relief can cause short-circuits at that point.
- Using positive-opening or direct-drive components installed and mounted in a positive mode.

## 3.8 Commissioning Checkout

After power is connected to the Muting Module, the EDM has been properly configured, and the OSSD outputs have been connected to the machine to be guarded, the operation of the Muting Module with the guarded machine must be verified before the combined system may be put into service. To do this, a Qualified Person must perform the Commissioning Checkout Procedure described in Section 6.2.

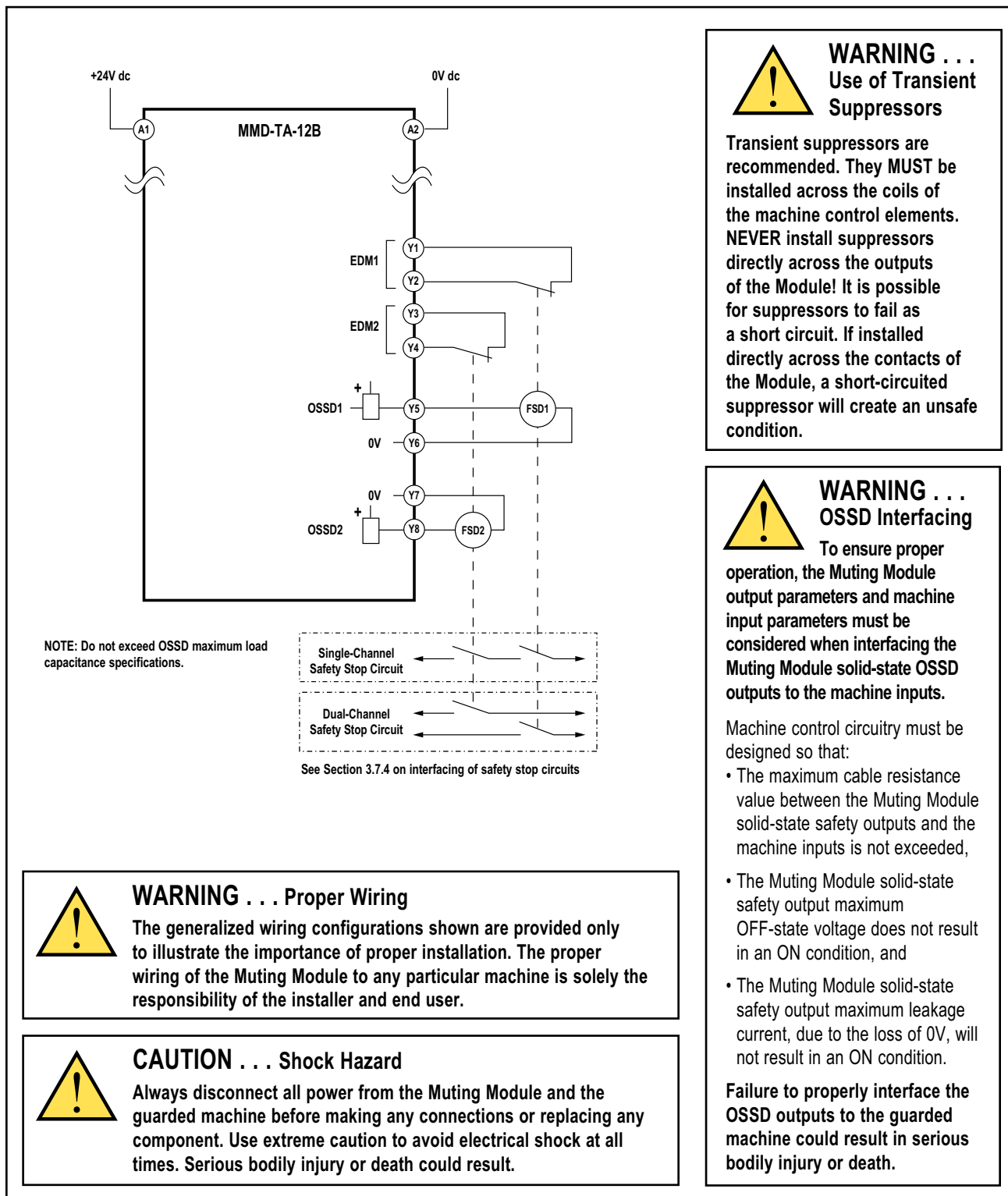

**WARNING . . . Use of Transient Suppressors**

Transient suppressors are recommended. They **MUST** be installed across the coils of the machine control elements. **NEVER** install suppressors directly across the outputs of the Module! It is possible for suppressors to fail as a short circuit. If installed directly across the contacts of the Module, a short-circuited suppressor will create an unsafe condition.

**WARNING . . . OSSD Interfacing**

To ensure proper operation, the Muting Module output parameters and machine input parameters must be considered when interfacing the Muting Module solid-state OSSD outputs to the machine inputs.

Machine control circuitry must be designed so that:

- The maximum cable resistance value between the Muting Module solid-state safety outputs and the machine inputs is not exceeded,
- The Muting Module solid-state safety output maximum OFF-state voltage does not result in an ON condition, and
- The Muting Module solid-state safety output maximum leakage current, due to the loss of 0V, will not result in an ON condition.

Failure to properly interface the OSSD outputs to the guarded machine could result in serious bodily injury or death.

Figure 3-24. Generic machine interface hookup: module model MMD-TA-12B, FSD with Two-Channel EDM

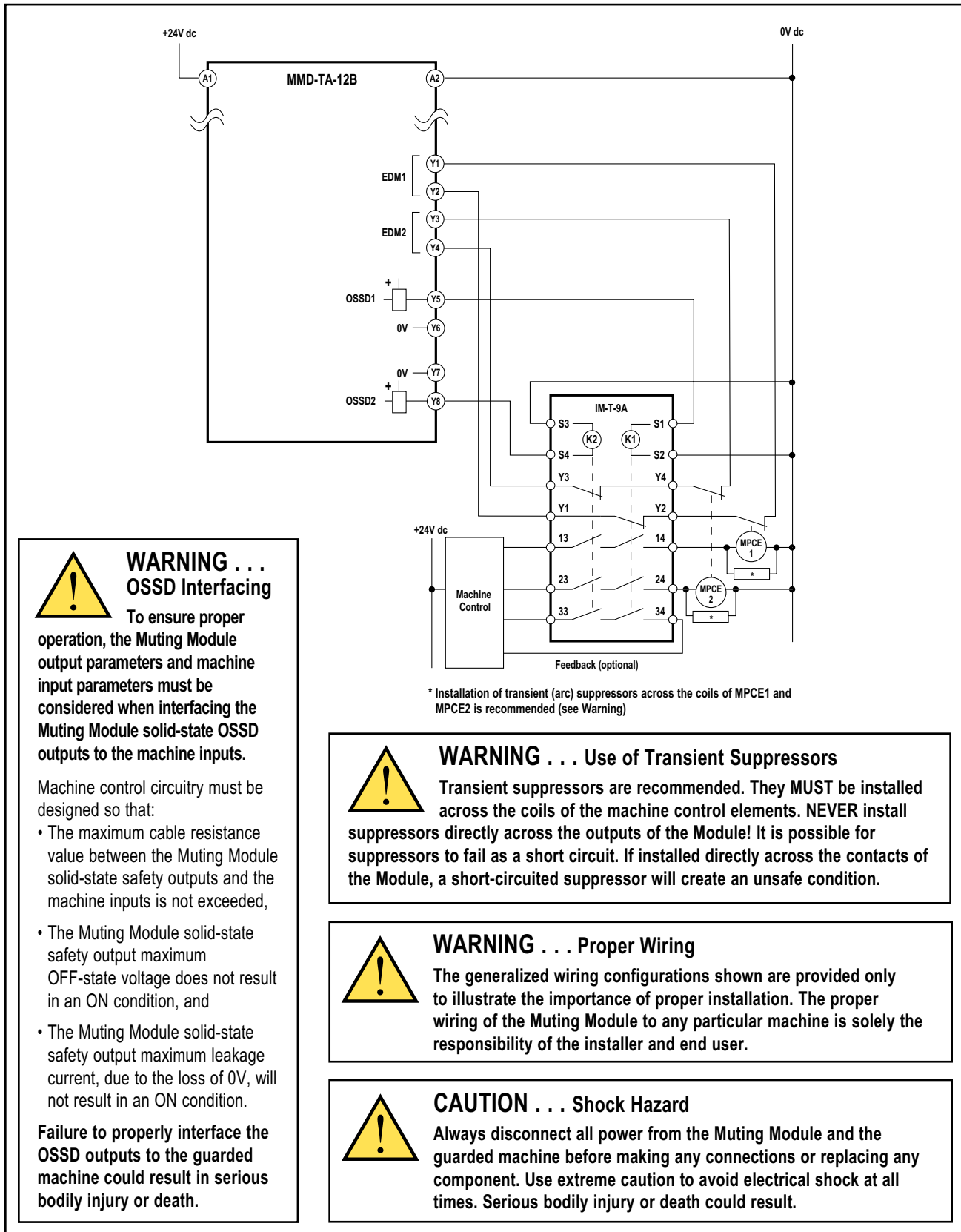

Figure 3-25. Generic machine interface hookup, model MMD-TA-12B: interface module with two-channel EDM

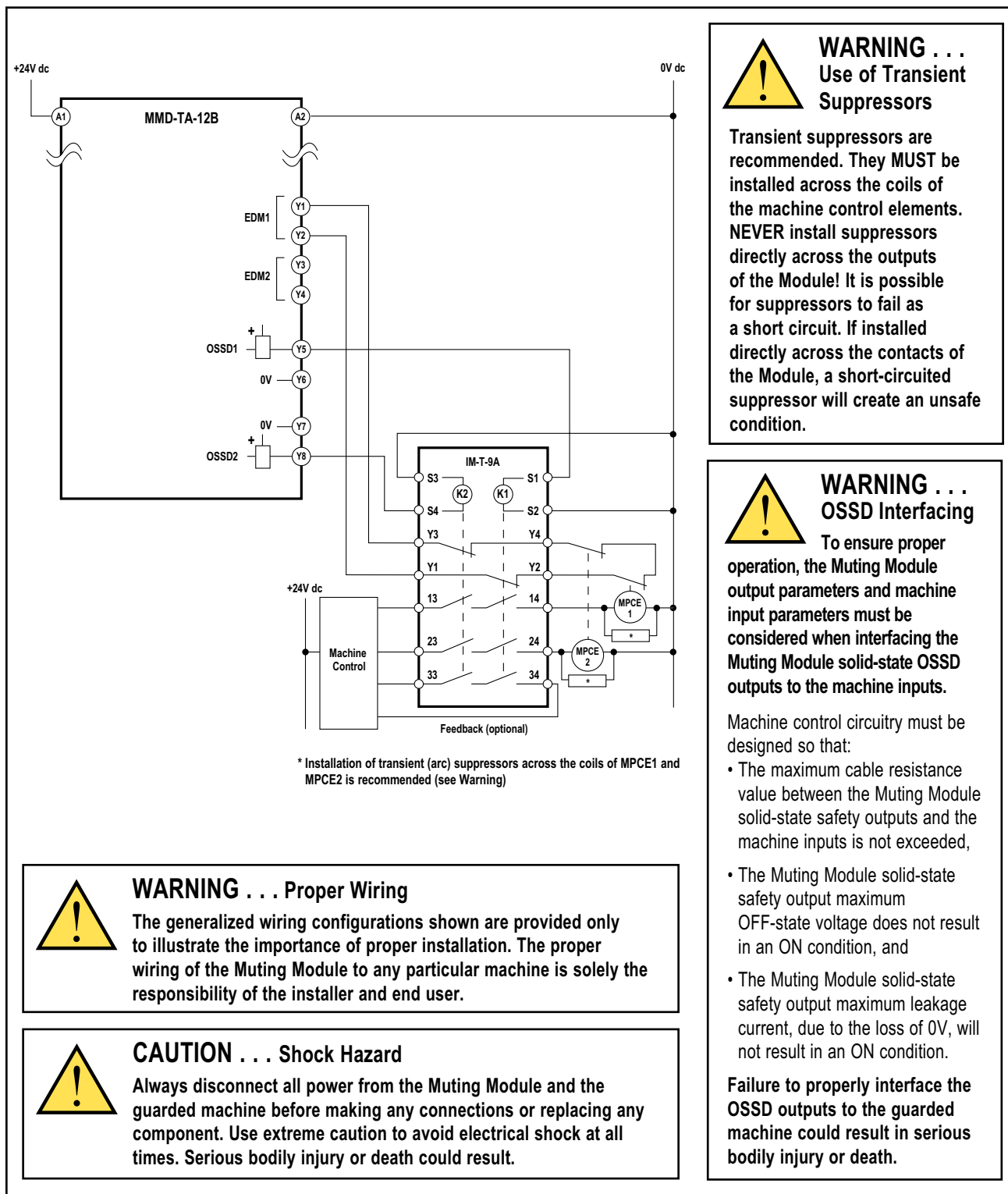

Figure 3-26. Generic machine interface hookup, model MMD-TA-12B: interface module with one-channel EDM

**WARNING . . . Proper Wiring**  
 The generalized wiring configurations shown are provided only to illustrate the importance of proper installation. The proper wiring of the Muting Module to any particular machine is solely the responsibility of the installer and end user.

**CAUTION . . . Shock Hazard**  
 Always disconnect all power from the Muting Module and the guarded machine before making any connections or replacing any component. Use extreme caution to avoid electrical shock at all times. Serious bodily injury or death could result.

**WARNING . . . Use of Transient Suppressors**  
 Transient suppressors are recommended. They **MUST** be installed across the coils of the machine control elements. **NEVER** install suppressors directly across the outputs of the Module! It is possible for suppressors to fail as a short circuit. If installed directly across the contacts of the Module, a short-circuited suppressor will create an unsafe condition.

**WARNING . . . OSSD Interfacing**  
 To ensure proper operation, the Muting Module output parameters and machine input parameters must be considered when interfacing the Muting Module solid-state OSSD outputs to the machine inputs.

Machine control circuitry must be designed so that:

- The maximum cable resistance value between the Muting Module solid-state safety outputs and the machine inputs is not exceeded,
- The Muting Module solid-state safety output maximum OFF-state voltage does not result in an ON condition, and
- The Muting Module solid-state safety output maximum leakage current, due to the loss of 0V, will not result in an ON condition.

Failure to properly interface the OSSD outputs to the guarded machine could result in serious bodily injury or death.

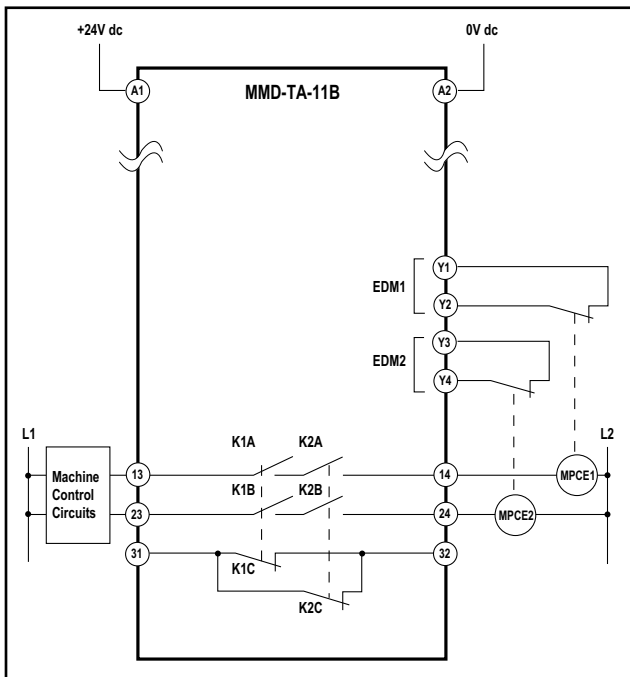

Figure 3-27. Generic machine interface hookup, model MMD-TA-11B: MPCE with 2-channel EDM

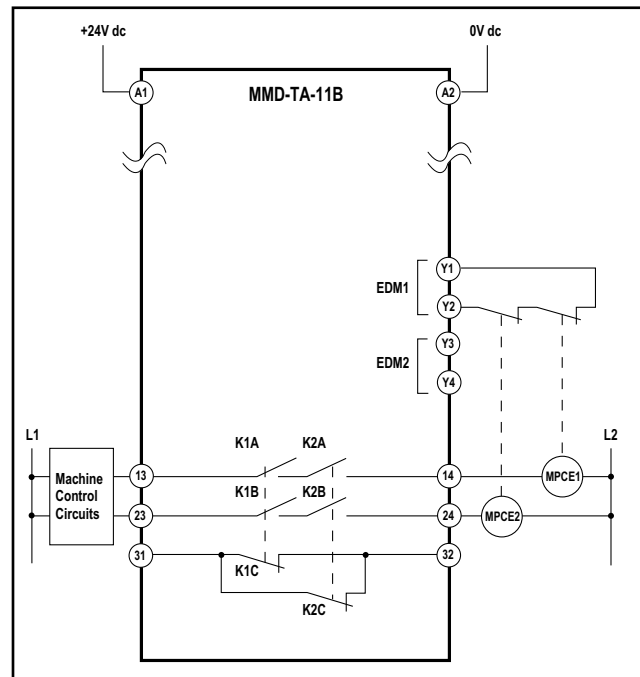

Figure 3-28. Generic machine interface hookup, model MMD-TA-11B: MPCE with 1-channel EDM



### WARNING . . . Use of Transient Suppressors

Transient suppressors are recommended. They **MUST** be installed across the coils of the machine control elements. **NEVER** install suppressors directly across the outputs of the Module! It is possible for suppressors to fail as a short circuit. If installed directly across the contacts of the Module, a short-circuited suppressor will create an unsafe condition.



### WARNING . . . Proper Wiring

The generalized wiring configurations shown are provided only to illustrate the importance of proper installation. The proper wiring of the Muting Module to any particular machine is solely the responsibility of the installer and end user.



### CAUTION . . . Shock Hazard

Always disconnect all power from the Muting Module and the guarded machine before making any connections or replacing any component. Use extreme caution to avoid electrical shock at all times. Serious bodily injury or death could result.

## 4. Operating Instructions

### 4.1 Security Protocol

The Module must be mounted inside a lockable enclosure or cabinet rated IP54 or better, both to protect the Module from environmental conditions and in order to prevent access by unauthorized personnel, if required by applicable standards.

The key (or combination) to the enclosure should be kept in the possession of a Qualified Person and only they should have access to the configuration switches. A Qualified Person is defined as an individual who, by possession of a recognized degree or certificate of professional training, or who, by extensive knowledge, training, and experience, has successfully demonstrated the ability to solve problems relating to the subject matter and work.

### 4.2 Periodic Checkout Requirements

In addition to the checkouts that are performed by a Qualified Person or persons at the time that the Module is installed and put into service, the functioning of the safeguarding and the machine must be verified on a regular periodic basis to ensure proper operation. This is absolutely vital and necessary. Failure to ensure proper operation can lead to serious injury or death.

See Section 6 for checkout schedules and procedures.



#### WARNING . . . Verify Proper Operation

The Muting Module and safety systems can do the job for which it was designed only if it and the machine it guards are operating properly, both separately and together. **It is the user's responsibility to verify proper operation, on a regular basis, as instructed in Section 6.**

**If the Muting Module, safety systems, and the guarded machine do not perform exactly as outlined in the checkout procedures, the cause of the problem must be found and corrected before the system is put back into service.**

**Failure to correct such problems can result in serious bodily injury or death.**

### 4.3 Normal Operation

During normal operation, the Module's three status indicators (red, green and yellow) are as shown in Figure 4-1. In addition, green and yellow indicators adjacent to each of the Module's inputs/interfaces come ON to verify an active state of that circuit.

During normal operation, the Diagnostic Display will read “—” (solid or, if during the mute cycle, flashing). If the 30- or 60-second Backdoor Timer feature is selected, the Diagnostic Display will begin to count down in seconds. If the 30-minute Backdoor Timer feature is selected, the timer countdown is in minutes. A flashing dash will appear on the display if the Backdoor Timer is OFF (infinite). If the Red status indicator begins to flash, the number that appears in the Display signifies an error; see Section 5.2 for more information.

See Section 3.5.1 for information on the reset routine.

	Waiting for Reset*	Output OFF	Output ON	Override	Lockout
<b>Red</b>	ON	ON	OFF	ON	Flashing
<b>Green</b>	OFF	OFF	ON	ON	OFF
<b>Yellow</b>	Flashing	ON	OFF	OFF	OFF

\* If either MSS1 or SSI set to MANUAL, the red Status LED will be OFF at power-up.

Figure 4-1. Muting module status indicator conditions



#### WARNING . . . Power Failures

**Power failures or other Module lockout conditions should always be investigated immediately by a Qualified Person. A lockout is a definite indication of a problem and should be investigated at once. Attempts to continue to operate machinery by bypassing the Module are dangerous and could result in serious bodily injury or death.**



## 5. Troubleshooting and Maintenance

### 5.1 Troubleshooting Lockout Conditions

A lockout condition causes the OSSD outputs to turn OFF, sending a stop signal to the guarded machine. A lockout condition is indicated by the Red status indicator flashing and an error code appearing in the Diagnostic Display. To clear a lockout condition, the failure must be corrected, the associated input must be properly cycled (if fault was due to an input failure), or a reset routine must be performed.

To perform a reset, close the reset input, hold closed for at least 1/4 second, but no longer than 2 seconds, and then re-open the input.

### 5.2 Diagnostic Display

The Module's Diagnostic Display is useful for monitoring the safeguarding system and for quickly diagnosing problems. See Figure 5-1 for a list of status codes and their meanings, along with recommended corrective actions.

### 5.3 Effects of Electrical Noise

The Module is designed and manufactured to be highly resistant to electrical noise and to operate reliably in industrial settings. However, serious electrical noise may cause a random lockout condition.

Check the following if a noise-related error code is displayed and other remedies have not cleared the problem:

- Sensor wires or input/output wires routed too close to "noisy" wiring.

In extreme conditions, it may be necessary to use shielded cabling or relocate the Module, mute devices, and cabling away from the source of the noise.

### 5.4 Repairs

NOTE: Do not attempt any repairs to the Module. It contains no field-replaceable components. Return the Module to the factory for warranty repair or replacement.

If it ever becomes necessary to return a Module to the factory, please do the following:

1. Contact the Banner applications engineering department at the numbers or address listed on the front cover. They will attempt to troubleshoot the system from your description of the problem. If they conclude that a component is defective, they will issue an RMA (Return Merchandise Authorization) number for your paperwork, and give you the proper shipping address.
2. Pack the Module carefully. Damage which occurs in shipping is not covered by warranty.



#### **WARNING . . . Shut Down Machinery Before Servicing**

The machinery connected to the Module must not be operating at any time during this procedure. You may be working close to a hazardous area of your machinery while servicing the Module. Servicing the Module while the hazardous machinery is operating could result in serious bodily injury or death.

Status Error Code	Condition / Error Type / Action	Status Error Code	Condition / Error Type / Action
— (Solid)	<b>System OK</b>	<b>39</b>	<b>EDM 2 Error</b> - Verify that input 2 is open (single-channel EDM selected) - Check wiring - Check operation of device(s) under control - Check DIP switch settings - Excessive EMI/RFI noise - EDM not closed at startup (Y3–Y4)
— (Flashing)	<b>Mute Cycle</b>		
<b>31</b>	<b>OSSD Output Error</b> - One OSSD is shorted to power/ground - OSSDs are shorted together		
<b>32</b>	<b>Reset Input Error</b> - Reset input shorted/closed	<b>40</b>	<b>2-Channel EDM Error</b> - Check wiring - Check operation of device(s) under control - Failed simultaneity between EDM1 and EDM2 (> 200 ms) - Both EDM open > 200 ms after OSSDs go OFF - Replace Module
<b>33</b>	<b>Module Error</b> - Excessive EMI/RFI noise - Internal failure, replace Module		
<b>34</b>	<b>MSSI Error*</b> - One or both channels shorted to power or ground - Input channels shorted together - One channel did not open - Failed simultaneity (>3sec) - Excessive EMI/RFI noise	<b>50</b>	<b>Backdoor Timer Expired</b> - Check muting device operation - Check muting device wiring - Check DIP switch settings - See Section 1.14
<b>35</b>	<b>Override Error</b> - Override input closed at power-up - Check Override input wiring and connector - Excessive EMI/RFI noise	<b>51</b>	<b>Mute Timing (Simultaneity) Error</b> - The second mute device of a pair (M1–M2 or M3–M4) did not actuate within 3 seconds of the first device. - Check muting device operation - Check wiring
<b>36</b>	<b>Mute Lamp Error</b> - Check/replace lamp (open or short) - Check wiring and connector - Check DIP switch settings	<b>52</b>	<b>Mute Enable Open Error</b> - ME input was open when a mute cycle was attempted - Check Mute Enable wiring
<b>37</b>	<b>DIP switch Error</b> - Check DIP switch settings - Replace Module	<b>61</b>	<b>SSI Input Error*</b> - One or both channels shorted to power or ground - Input channels shorted together - One channel did not open - Failed simultaneity (> 3 sec) - Excessive EMI/RFI noise
<b>38</b>	<b>EDM 1 Error</b> - Check wiring - Check operation of device(s) under control - Check DIP switch settings - Switching transition > 200 ms - Excessive EMI/RFI noise - EDM remains open > 200 ms after OSSDs go OFF (if dropout time verification check on) - EDM not closed at startup	<b>Flashing Mute Lamp</b>	<b>Override Condition</b>

\*Fault is cleared by cycling the input from open-to-closed.

Figure 5-1. Troubleshooting conditions, using the Module's Diagnostic Display

## 6. Periodic Checkout Procedures

Study each procedure from beginning to end before you start to make sure that you understand each step. Refer all questions to the Banner Applications Engineering Department at the address or numbers listed on the front cover of this manual. Checkouts must be performed as detailed in Section 6.1 below and results should be recorded and kept in the appropriate place (e.g., near the machine, and/or in a technical file).

### 6.1 Schedule of Checkouts

**Initial Checkout:** The procedure for initial checkout of the Module and its interconnected components is described in Section 3.6. This procedure is performed at installation, and at any time the System, the guarded machine, or any part of the application is installed or altered. The procedure must be performed by a Qualified Person.

**Commissioning Checkout:** Should be performed after installation or whenever changes are made to the system (either a new configuration of the safety system that includes the MMD-TA-1..B module or changes to the machine). The procedure must be performed by a Qualified Person. See Section 6.2.

**Daily Checkout:** The procedure for “daily” checkout of the safety system that includes the MMD-TA-1..B module is to be performed at each shift change or machine setup change, whenever the System is powered up, at least daily. The procedure may be performed by a Designated Person or a Qualified Person. See Section 6.3.

**Semi-Annual Checkout:** The procedure for initial checkout of the safety system that includes the MMD-TA-1..B module is to be performed every six months, following installation of the System. The procedure must be performed by a Qualified Person. See Section 6.4.



#### **WARNING . . . Do Not Use Machine Until System Is Working Properly**

**If all of these checks cannot be verified, do not attempt to use the safety system that includes the MMD-TA-1..B Module/guarded machine until the defect or problem has been corrected (see Section 5).**

**Attempts to use the guarded machine under such conditions could result in serious bodily injury or death.**



#### **WARNING . . . Before Applying Power to the Machine**

**Verify that the guarded area is clear of personnel and unwanted materials (such as tools) before applying power to the guarded machine.**

**Failure to do so could result in serious bodily injury or death.**

### 6.2 Commissioning Checkout

Perform this checkout procedure as part of Safeguarding System installation (after the System has been interfaced to the guarded machine as described in Sections 3.6 and 3.7), or whenever changes are made to the System (either a new configuration of the Module, devices connected to it, or changes to the machine). A Qualified Person (as defined in the Safety Glossary) must perform the procedure; checkout results should be recorded and kept on or near the guarded machine, per OSHA 1910.217(e)(1).

To prepare the Module for this checkout, ensure the configuration is as it will be during machine operation.

#### **Safeguarding Checkout**

1. Examine the guarded machine to verify that it is of a type and design compatible with the safeguarding system that has been installed. See page 2.
2. Verify the system(s) checkout procedures for the external safety systems connected to the MSS1 and the SSI inputs as described by the appropriate manuals. Do not proceed until all checkout procedures are completed successfully and all problems have been corrected.
3. Verify that:
  - Access to any dangerous parts of the guarded machine is not possible from any direction not protected by the safeguarding system, hard guarding, or supplemental safeguarding, and that
  - Supplemental safeguarding and hard guarding, as described by the appropriate safety standards, are in place and functioning properly.
4. Verify that the Reset switch is mounted outside the guarded area, out of reach of anyone inside the guarded area, and that means of preventing inadvertent use is in place.
5. Examine the electrical wiring connections between the Module's OSSD outputs and the guarded machine's control elements to verify that the wiring meets the requirements stated in Section 3.7.

6. Apply power to the Module. Ensure that power to the guarded machine is OFF. Verify that the external safety systems are providing a Green/Go signal to the MSSSI and SSI inputs, and that the Green MSSSI and SSI indicators (two pairs of LEDs located near each terminal) are ON. When configured for Manual Reset, the Yellow status indicator will be flashing. Perform a manual reset (close the Reset switch for 1/4 to 2 seconds, then open the switch). Verify that the Green status indicator is ON steady.

NOTE: A Red flashing status indicator signifies a lockout condition. Refer to Section 5 for information.

7. In a non-muted condition, generate a stop command from the safeguarding device connected to the MSSSI (e.g. interrupt the defined area of a safety light screen). Verify that MSSSI Channel A and B and the Green status indicators go OFF. In order, reset the safeguard and then the Module (in Manual Reset).
8. Generate a stop command from the safeguarding device connected to the SSI (e.g., actuate E-stop button). Verify that SSI Channel A and B and the Green status indicators go OFF. In order, reset the safeguard and then the Module (in Manual Reset).
9. Apply power to the guarded machine and verify that the machine does not start up. Generate a stop command from the safeguarding device connected to the SSI and the MSSSI in a non-muted condition. Verify that it is not possible for the guarded machine to be put into motion while either stop commands are present. In order, reset the safeguard and then the Module (in Manual Reset).
10. Initiate machine motion of the guarded machine and, while it is moving, as in step #9 above, generate a stop command from each safeguarding device. Do not attempt to insert anything into the dangerous parts of the machine. Upon issuing the stop command, the dangerous parts of the machine should come to a stop with no apparent delay. Upon reset of the safeguard and the Module, verify that the machine does not automatically restart, and that the initiation devices must be engaged to restart the machine.
11. Remove electrical power to the Module. All OSSD outputs should immediately turn OFF, and should not be capable of turning ON until power is re-applied and a reset is accomplished.
12. Test the machine stopping response time, using an instrument designed for that purpose, to verify that it is the same or less than the overall system response time specified by the machine manufacturer. (Banner's Applications Engineering Department may be able to recommend a suitable instrument.)

**Do not continue operation until the entire checkout procedure is complete and all problems are corrected.**

### Muting Checkout

13. Verify that the Module has been reset and the Green status indicator is ON. If the Yellow status indicator is flashing (indicating the safety system that includes the MMD-TA-1..B module is waiting for a reset of a latched condition), perform a manual reset. At any time, if the Red status indicator begins to flash, a lockout condition exists. Refer to Section 5.1 to determine the cause of the lockout.

**During this procedure, at all times ensure that personnel are not exposed to any hazard.**

14. Mute the system by blocking (or activating) both mute devices (typically M1–M2) simultaneously (within 3 seconds).
15. Verify that the Mute indicator comes ON. If not, check the indicator and its wiring, verify that the mute enable input is closed, and check the Diagnostic Display for error codes.
16. Generate a stop command from the safeguarding device connected to the MSSSI; verify the green MSSSI channel indicators are OFF and the Green status indicator is ON.

NOTE: If the Backdoor Timer feature has been selected, the Diagnostic Display will begin to count down; otherwise a flashing dash will appear on the display.

17. Clear or reset the safeguard (before the Backdoor Timer expires) and verify the green MSSSI channel indicators are ON. Clear (deactivate) the mute devices before the Backdoor Timer expires and verify the Mute indicator goes OFF. The Green status indicator should remain ON.
18. Verify that it is not possible for a single individual to initiate a mute condition by triggering the mute devices (for example, by blocking both photoelectric beams or actuating both switches) and access the hazard without being detected and issuing a stop command to the machine (where the green status indicator goes OFF, and a reset of the latch condition is required). Do not expose any individual to hazard while attempting to mute the system.
19. Verify that it is not possible for personnel to pass in front of, behind, or next to the muted object without being detected and without issuing a stop command to the machine.
20. If one-way (directional) muting has been selected, verify that the system can not be muted by blocking (or activating) M3–M4 before M1–M2. Do not expose any individual to hazard while attempting to mute the system.

**If any of these checks fail, do not attempt to use the safety system that includes the MMD-TA-1..B module until the reason for the failure(s) is identified and corrected.**

### 6.3 Daily Checkout

Perform this checkout procedure at every shift change, power-up and machine set-up change. During continuous machine run periods, this checkout must be performed at intervals not to exceed 24 hours. A Designated Person or Qualified Person (as defined in Section 1.18) must perform the procedure; checkout results should be recorded and kept on or near the guarded machine, per OSHA 1910.217(e)(1).

1. Verify that access to the guarded area is not possible from any area not protected by the safeguards interfaced with the safety system that includes the MMD-TA-1..B module. Hard guarding, or supplemental presence-sensing devices must be installed, wherever needed, to prevent any person from reaching around the light grid or entering into the hazard area. Verify that all supplemental guarding devices and hard guarding are in place and operating properly.
2. Verify that the safeguards interfaced with the safety system that includes the MMD-TA-1..B module have been properly installed and maintained. See relevant instruction manuals or data sheets.
3. Verify that it is not possible for a person to access the hazard(s), undetected by the safeguards interfaced with the safety system that includes the MMD-TA-1..B module or by other supplemental guarding (as described in appropriate standards).
4. Verify that the Reset switch is mounted outside the guarded area, out of reach of anyone inside the guarded area, and that the key or other means of preventing inadvertent use is in place.
5. Verify the system(s) checkout procedures for the external safety systems connected to the MSS1 and the SSI inputs as described by the appropriate manuals.
6. Initiate machine motion of the guarded machine and, during the cycle, generate a stop command from the safeguarding device. Do not attempt to insert anything into the dangerous parts of the machine. Upon issuing the stop command, the dangerous parts of the machine should come to a stop with no apparent delay. Upon reset of the safeguard and the Module, verify that the machine does not automatically restart, and that the initiation devices must be engaged to restart the machine.

7. With the guarded machine at rest, generate a stop command from the safeguarding device(s) and verify that it is not possible for the guarded machine to be put into motion.
8. Check carefully for external signs of damage or changes to the safety system that includes the MMD-TA-1..B module, the interfaced safeguards, the guarded machine, and their electrical wiring. Any damage or changes found should be immediately reported to management.

**If any of these checks fail, do not attempt to use the safety system that includes the MMD-TA-1..B module until the reason for the failure(s) is identified and corrected.**

### 6.4 Semi-Annual Checkout

Perform this checkout procedure every six months following the safety system that includes the MMD-TA-1..B module installation. A Qualified Person (as defined in Section 1.18) must perform the procedure; checkout results should be recorded and kept on or near the guarded machine, per OSHA 1910.217(e)(1).

1. Perform the commissioning checkout procedure (Section 6.2) If any decrease in machine braking ability has occurred, make the necessary clutch/brake repairs, readjust safeguard separation distance (Ds) appropriately, record the new Ds calculation, and re-perform the Daily Checkout procedure.
2. Examine and test the machine primary control elements (MPCEs) and any intermediary controls (such as interface modules) to verify that they are functioning correctly and are not in need of maintenance or replacement.
3. Inspect the guarded machine to verify that no other mechanical or structural problems could prevent the machine from stopping or assuming an otherwise safe condition when signalled to do so by the safety system that includes the MMD-TA-1..B module.
4. Examine and inspect the machine controls and connections to the safety system that includes the MMD-TA-1..B module to verify that no modifications have been made which adversely affect the System.

**If any of these checks fail, do not attempt to use the safety system that includes the MMD-TA-1..B module until the reason for the failure(s) is identified and corrected.**

## Appendix A. Mute Timing Sequences

### Muting Sequence with Two Muting Devices

(For example, "X"-pattern Entry/Exit System, see Figure B-1)

#### DIP Switch Configuration\*:

- MSSI Auto or Manual Reset . . . SW1 = OFF (Manual)
- SSI Auto or Manual Reset . . . . SW2 = OFF (Manual) or ON (Auto)
- One-Way Muting . . . . . SW3 = OFF (1-way)
- Two-/One-Channel EDM . . . . . SW4 = OFF (2 CH)
- Backdoor Timer . . . . . SW5&6 = OFF (30 sec.)
- Monitored Muting Lamp . . . . . SW7 = OFF (Mon)
- Mute on Power-up . . . . . SW8 = OFF (Disable)

\*Both DIP switch banks A and B.

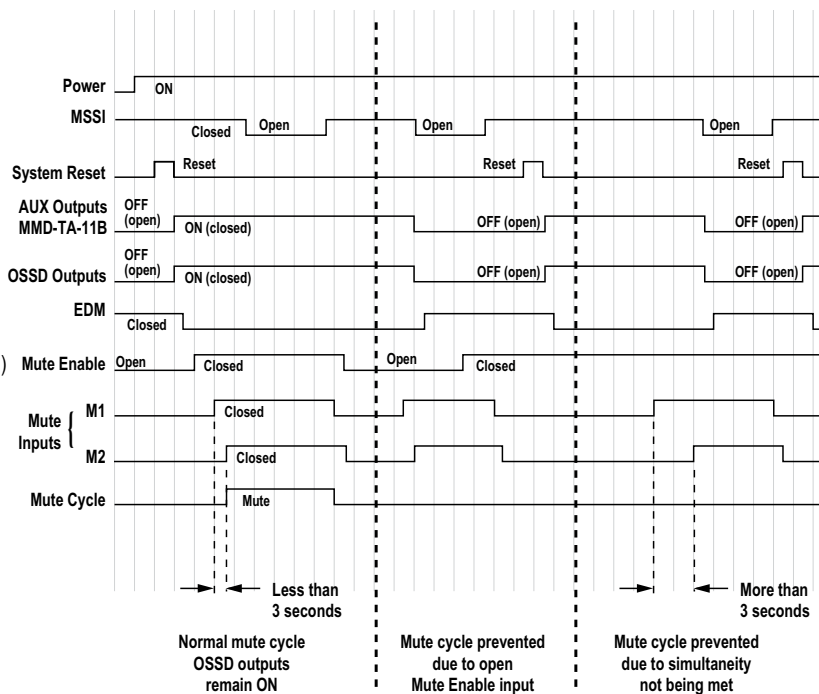

### Muting Sequence with Four Muting Devices

(For example, an Entry/Exit System using four photoelectric devices; see Figure B-5)

#### DIP Switch Configuration\*:

- MSSI Auto or Manual Reset . . . SW1 = OFF (Manual)
- SSI Auto or Manual Reset . . . . SW2 = OFF (Manual) or ON (Auto)
- One-Way Muting . . . . . SW3 = OFF (1-way)
- Two-/One-Channel EDM . . . . . SW4 = OFF (2 CH)
- Backdoor Timer . . . . . SW5&6 = OFF (30 sec.)
- Monitored Muting Lamp . . . . . SW7 = OFF (Mon)
- Mute on Power-up . . . . . SW8 = OFF (Disable)

\*Both DIP switch banks A and B.

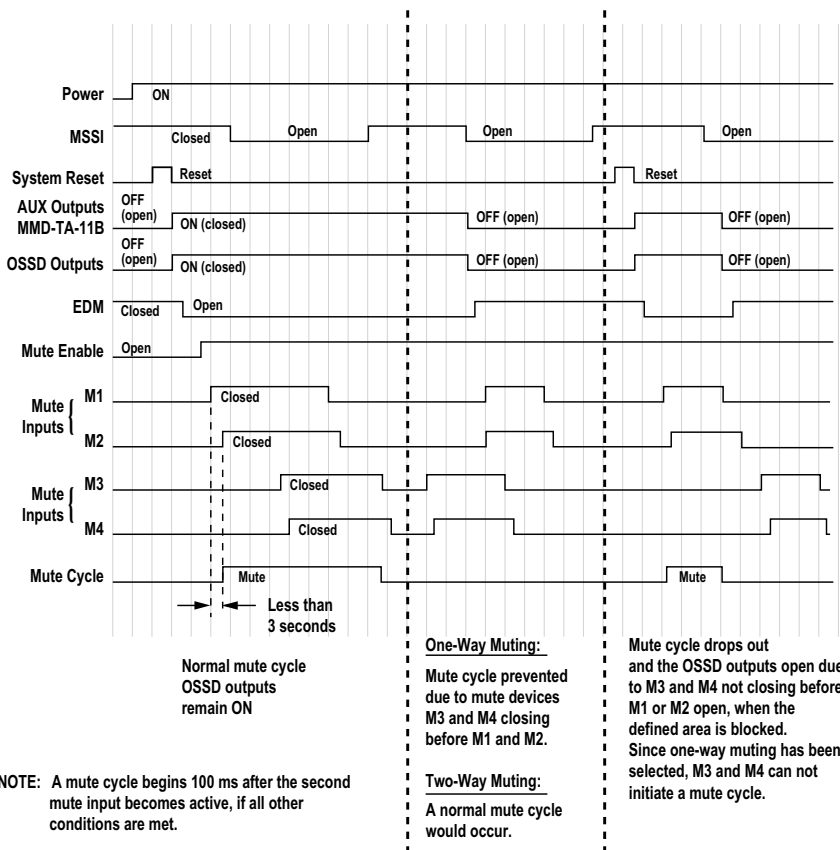

NOTE: A mute cycle begins 100 ms after the second mute input becomes active, if all other conditions are met.



## Appendix B. Typical Muting Applications

### Entry/Exit Applications

The muting devices must be placed to ensure that the points that trigger the mute's start and end are very close to the safety light screen's sensing field. This prevents personnel from following, or being pushed by, the object into the hazardous area without interrupting the safety light screen before the mute window opens or at the time the mute window closes.

When two pairs of opposed-mode photoelectrics are used as muting devices, as shown below, the crossing point of the two sensing paths must be on the hazardous side of the safety light screen. The safety light screen will be interrupted before any personnel would be able to block both beams and mute the system. The devices should detect the material and not the pallet or the transport in order to hinder an individual from riding into the hazardous area.



### WARNING . . .

- It must not be possible for an individual to block both photoelectric beams (dashed diagonal lines in Figure B-1) and initiate a mute condition. Check the installation to verify that unintentional muting is not possible. The "crossing point" of the photoelectric beams must be located in the hazardous area and not be accessible to personnel (by reaching over, under, through, or around).
- It must not be possible for personnel to walk in front of, behind, or next to the muted object (e.g., the carrier basket) without being detected and stopping the hazardous motion. Supplemental safeguarding must be used to prevent personnel from entering the hazardous area during a mute condition.

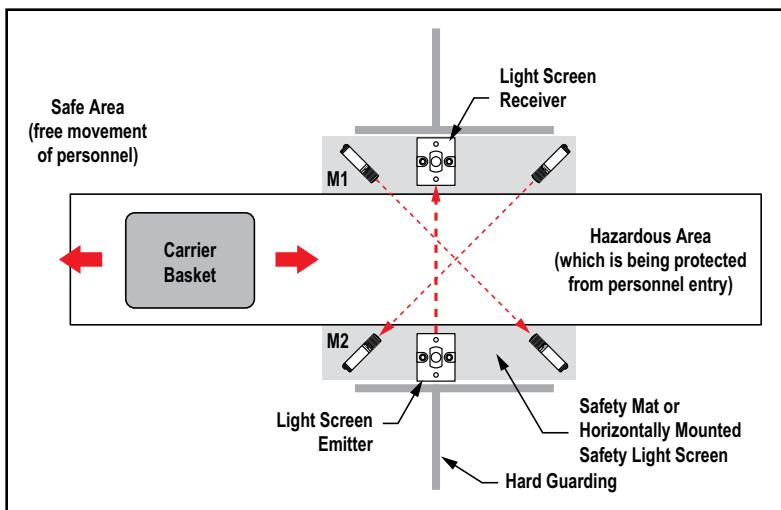

Figure B-1. "X"-Pattern Entry/Exit system using two pairs of opposed-mode photoelectric muting devices

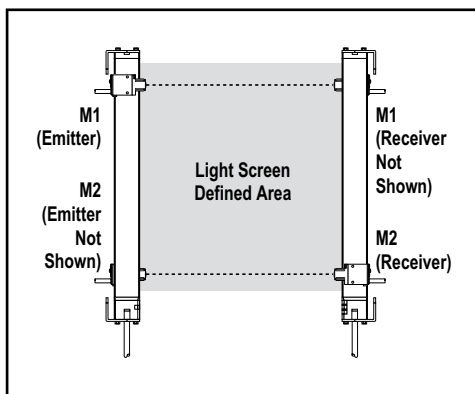

Figure B-2. Horizontal photoelectric muting devices placed at different heights

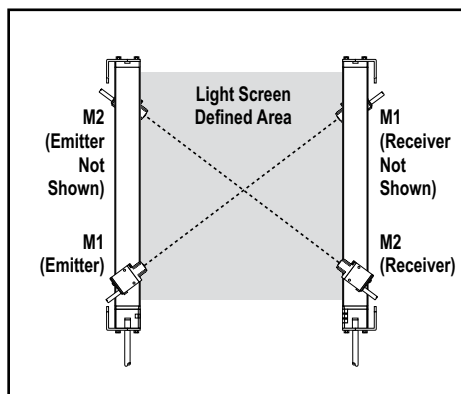

Figure B-3. Photoelectric muting devices placed diagonally

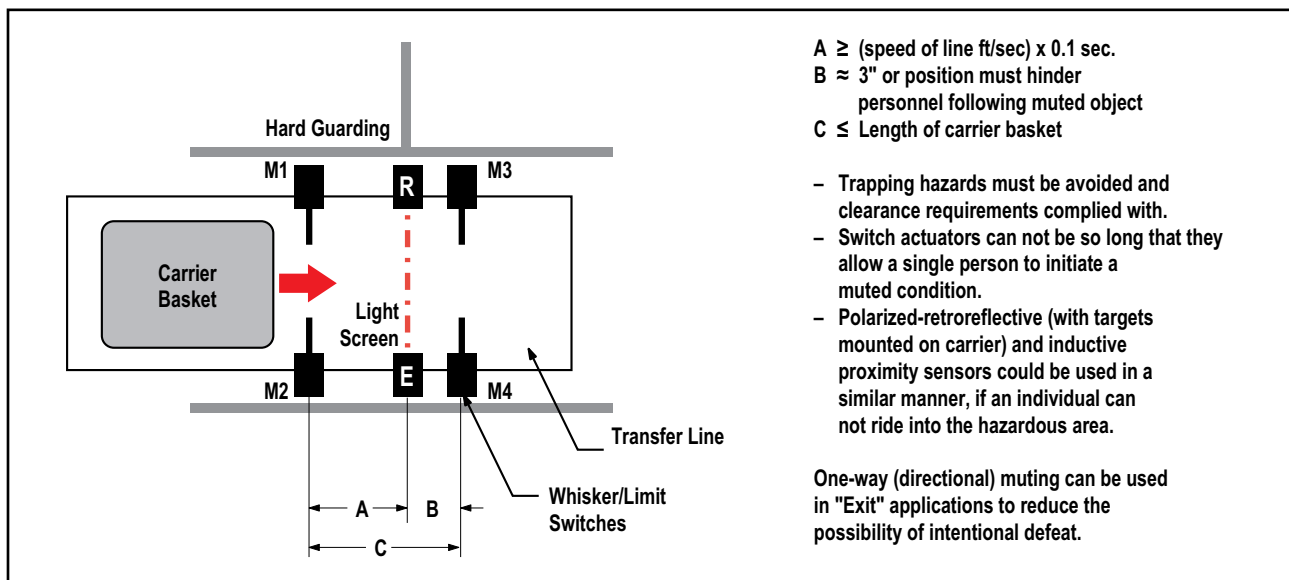

Figure B-4. Entry/exit system using 4 whisker/limit switches as muting devices

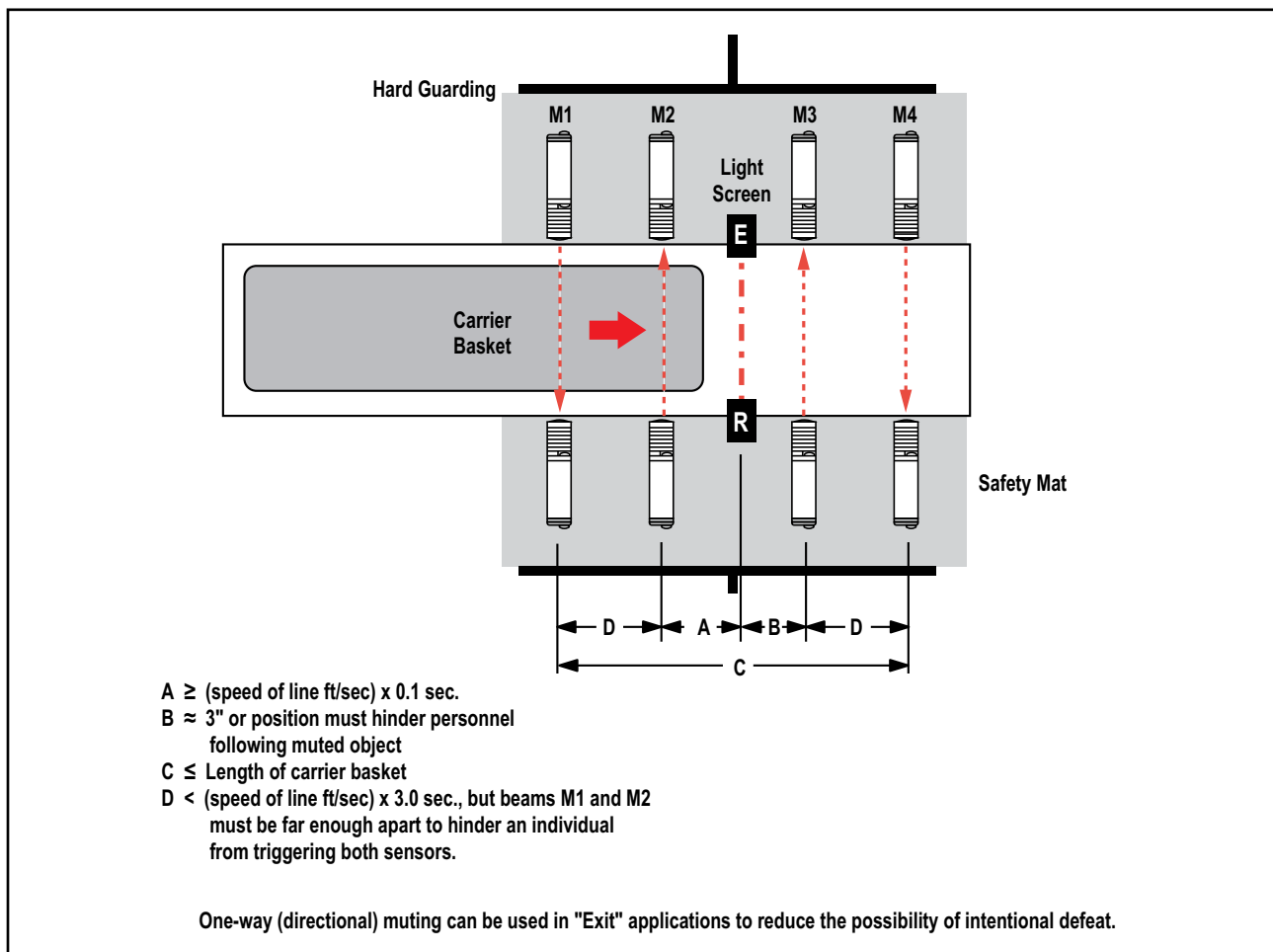

Figure B-5. An entry/exit system using four photoelectric sensors as M1, M2, M3, and M4

### Home or Station Applications

The muting devices must be placed to ensure that the safety light screen is muted *only* when the hazard does not exist or is in another area so that personnel are not exposed. The muting devices must be placed so that if a hazard arises, or the hazard enters the safeguarded area, the mute will immediately end and the safeguard will be active once again.

In “home position” muting applications, the light screen is active only while motion is taking place or a hazard is present, such as the closing of an automated door. In this example, the door is interlocked and the machine can not start until the opening is completely closed. The hazard being guarded by the light screen is the pinch point caused by the door closing.

M3 and M4 could be two SI-QS75MC safety switches, each with a single safety contact used for the muting input. M1 and M2 could be SI-QS90MF safety switches, each with two safety contacts (one for muting and one for interlocking) and one monitoring contact for a logic input.

If the light screen is also guarding hazards within the enclosure when the door is open or preventing cycle initiation, then switches M3 and M4 would not be used. The door could also be “locked” by using locking style safety switches, such as the SI-QM100 or SI-LS42 as M1 and M2.

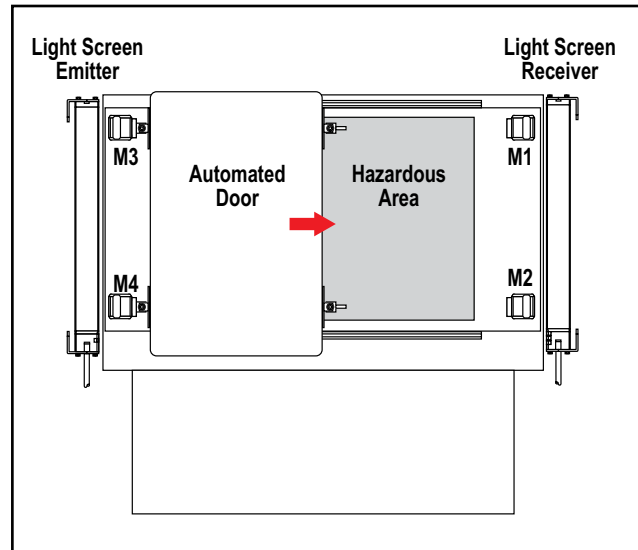

Figure B-6. A “home position” (door) muting application, using 4 safety switches as muting devices



### **WARNING . . . User is Responsible for Safe Application of this Product**

The muting application examples described in Appendix B depict generalized guarding situations. Every guarding application has a unique set of application requirements. **Extreme care is urged to ensure that all legal requirements are met and that all installation instructions are followed.**

In addition, any questions regarding safeguarding should be directed to the factory applications department at the telephone number or addresses listed on the back cover.

**Robot Load/Unload Station Application**

This “station” muting application uses two independent safety light screen circuits, each with its own muting circuit and muting devices (e.g. polarized-retroreflective photoelectrics). The application also includes run bars with two-hand control, auxiliary controls, and E-Stop. The two-hand control is provided at each station to safeguard the operator during the momentary clamping action of the fixture while the safety light screen is muted.

In this example, the safety light screens are angled outwards (see Figure B-7, detail A). This provides proper separation distance from the hazards created by the robot and the clamping/welding fixtures, while protecting against the possibility of pass-through hazards. In muting applications involving an operator, the operator must be continually detectable by the defined area. This ensures that if a hazard arises, causing the mute to end while the operator is present, the safety light screen will immediately issue a stop.

While the robot is at station “A”, the light screen at station “B” is muted (M1B and M2B are active), allowing the operator to load or unload without issuing a stop command to the robot. As the robot moves out of the “A” work envelope (as defined by Station “B” mute devices, see detail B) the mute discontinues at station “B”. If the operator is still within the protected area, a stop command is immediately issued. As the robot moves to the work envelope of station “B”, the mute devices M1A and M2A activate and mute the safety light screen at station “A.”

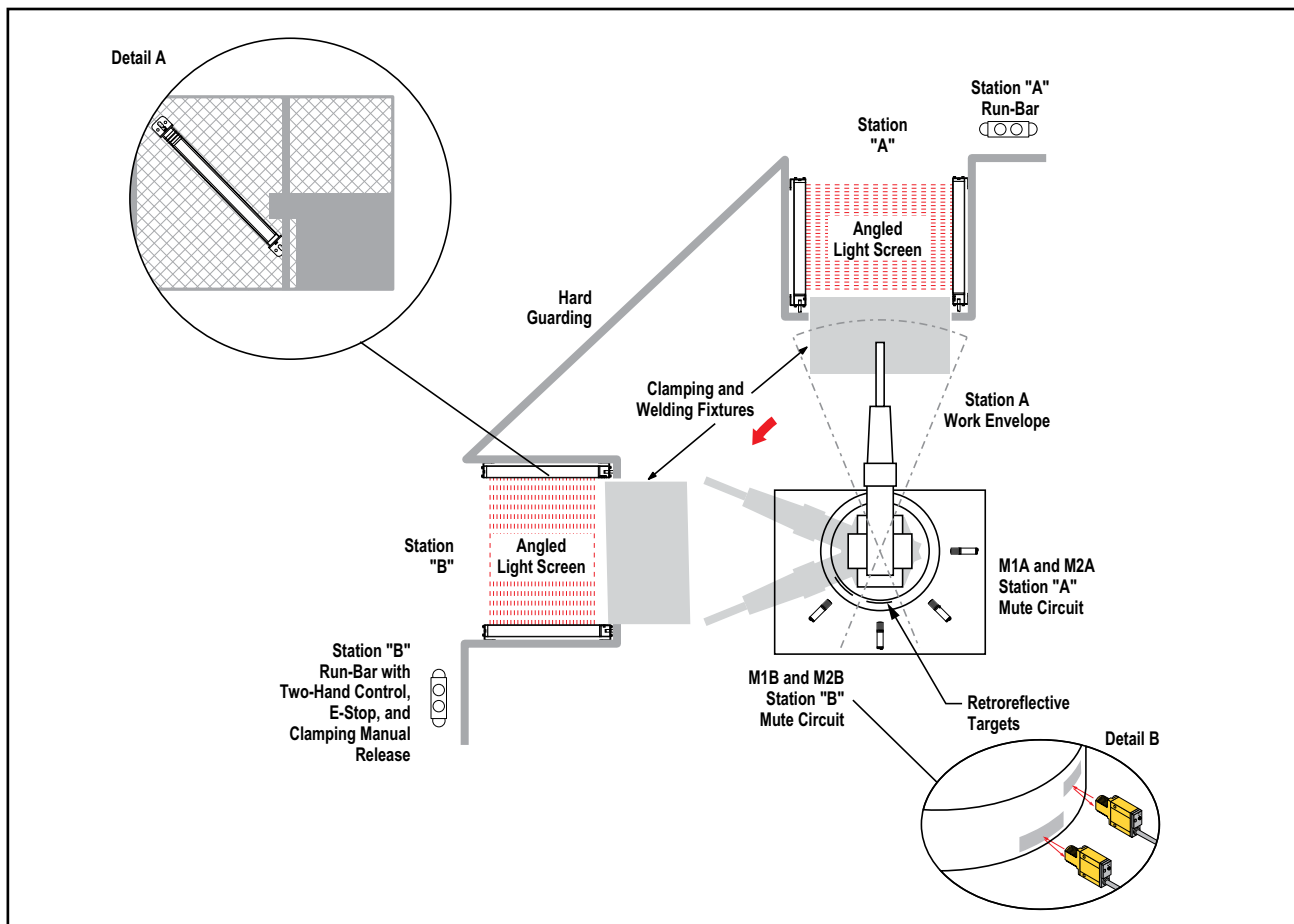

Figure B-7. A robot load/unload application with two-station home-position muting, using polarized retroreflective photoelectrics as muting devices

### Turret Table Application

A "Turret Table" application is similar to the Robot Load/Unload Station muting application, except that any movement of the table ends the mute. To accomplish this, small retroreflective targets (or tape) are positioned so that they will initiate the mute (the sensors must be set to "Light Operate") only after the table has finished indexing. (NOTE: The example shows four pairs of targets, one pair for each position.)

When the table begins indexing again, the polarized-retroreflective photoelectrics immediately "lose sight" of the targets and end the mute. Since the rotation of the table is the hazard, the size and positioning of the targets must prevent muting while motion is taking place.

The top of the emitter and receiver are angled outwards to maintain proper separation distance while preventing a pass-through hazard. Hard guarding, or other safeguarding, must be positioned to prevent personnel from reaching through and accessing any hazard.

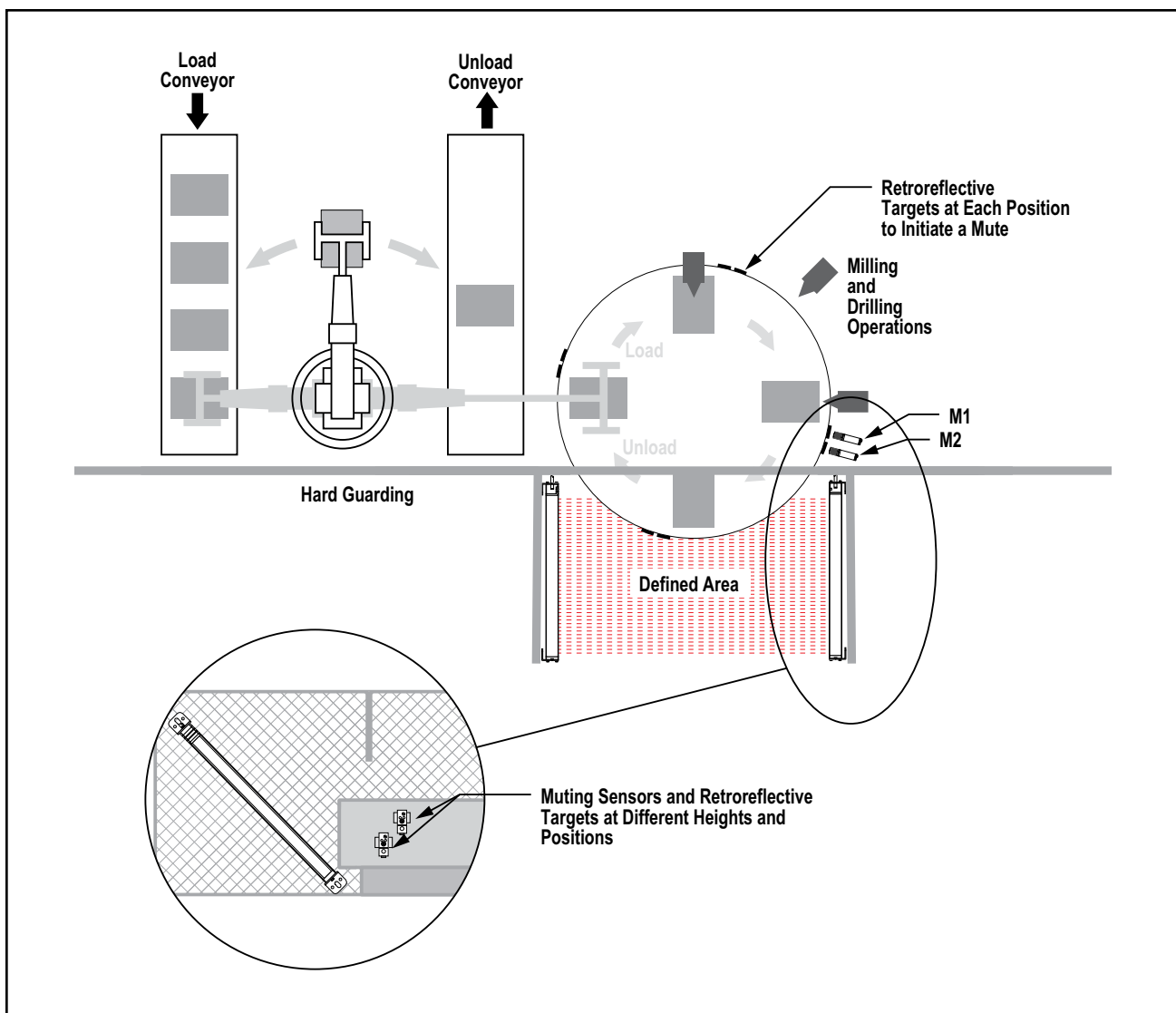

Figure B-8. A typical application for turret table inspection or operation station muting, using retroreflective photoelectric sensors as muting devices

### Power Press Applications

Muting is allowed on power presses only during the non-hazardous portion of the cycle (e.g. the upstroke), per OSHA1910.217, ANSI B11.1, B11.2, and B11.3. The mute permits the insertion or removal of material into the press that would otherwise block the sensing field of the safety light screen, causing the press to stop. Muting should not be confused with “Inch” or “Jog” modes, whose manual selection may bypass the safety light screen within the machine control.

For the proper application of muting on a power press, at a minimum, two (or four) independent position switches (such as cam-operated limit switches, inductive prox sensors, or pressure switches) must be used to initiate the mute during the non-hazardous portion of the machine cycle. These position switches would be mute devices M1/M2 (and M3/M4 if used). Typically, these switches have normally open contacts, which are held (or actuated) closed during the mute cycle.

These switches must be mounted separately to prevent misadjustment, misalignment, or a single common mode failure, which would result in an improper mute cycle or otherwise unsafe condition. They must be installed so that they can not be easily defeated or bypassed, and their adjustment should be under supervisory control.

The two (or four) muting devices must be properly adjusted (or positioned) so that they close only after the hazard no longer exists and then open when the cycle is complete (top of stroke) or when the hazard is again present. If improperly adjusted or positioned, injury or death could result.

If the machine has reversing capability where a hazard is possible during a muted condition, the control must include an automatic means through which muting is permitted in the forward (non-hazardous) direction only. A “Mute Enable” signal from the machine control, motor drive, or other machine logic, is a means to assist in meeting this requirement.

In muting applications involving an operator, all pass-through hazards must be eliminated so that the operator is continually detected when in the defined area. This ensures that if a hazard arises, causing the mute cycle to end while the operator is present, the safety light screen will immediately issue a stop. (See pass-through hazard information below.)

A “pass-through hazard” is associated with applications that allow personnel to pass through a safeguard, which removes or stops the hazard(s), and then allows the individual to continue into the hazardous area. Subsequently the individual’s presence is no longer detected, and the safeguard can not prevent the start or restart of the machine. A pass-through can be created by as little as 75 mm (3”) space between the defined area and machine frame. If the safety light screen is muted while the individual passes through the defined area, a stop command will not be issued and the hazard cannot be eliminated; the individual must be detected while entering the safeguarded area and the hazardous motion must stop immediately. This is typically accomplished by supplemental safeguarding such as described in ANSI B11 standards or other appropriate standards.



#### **WARNING . . . Proper Installation**

The user has the responsibility to ensure that all local, state, and national laws, rules, codes, and regulations in any particular application are satisfied. It is extremely important to be sure that all appropriate agency requirements have been met. See inside back cover for appropriate standards.



## Glossary of Terms

**ANSI (American National Standards Institute):** the American National Standards Institute, an association of industry representatives that develops technical standards (including safety standards). These standards comprise a consensus from a variety of industries on good practice and design. ANSI standards relevant to application of safety products include the ANSI B11 Series, and ANSI/RIA R15.06. See "Safety Standards" on inside back cover.

**Auto Power-Up:** a safety light screen system feature which, when switched ON, enables the system to be powered up (and recover from a power interruption) without requiring a manual reset. When Auto Power-Up is ON, the safety light screen controller automatically begins internal diagnostics upon power-up, and automatically resets the system if it passes the diagnostic check. When Auto Power-up is OFF, a manual reset is required.

**Blocked Condition:** A safety light screen condition, when an opaque object of sufficient size blocks/interrupts one or more light screen beams. When a Blocked condition occurs, OSSD1 and OSSD2 outputs simultaneously turn off within the system response time.

**Brake:** a mechanism for stopping or preventing motion..

**Clutch:** a mechanism that, when engaged, transmits torque to impart motion from a driving member to a driven member.

**Control Reliability:** A method of ensuring the performance integrity of a control system. Control circuits are designed and constructed so that a single failure or fault within the system does not prevent the normal stopping action from being applied to the machine when required, or does not create unintended machine action, but does prevent initiation of successive machine action until the failure is corrected.

**CSA:** Canadian Standards Association, a testing agency similar to Underwriters Laboratories, Inc. (UL) in the United States. A CSA-certified product has been type-tested and approved by the Canadian Standards Association as meeting electrical and safety codes.

**Defined Area:** the "screen of light" generated between the emitter and receiver of a safety light screen system. When the defined area is interrupted by an opaque object of a specified cross section, a Trip or Latch condition results.

**Designated Person:** an individual identified and designated in writing, by the employer, as being appropriately trained and qualified to perform a specified checkout procedure. (See Qualified Person.)

**Emitter:** the light-emitting component of a safety light screen system, consisting of a row of synchronized modulated LEDs. The emitter, together with the receiver (placed opposite), creates a "screen of light" called the defined area.

**External Device Monitoring (EDM):** a means by which a safety device (such as a safety light screen) actively monitors the state (or status) of external devices that may be controlled by the safety device. A lockout of the safety device will result if an unsafe state is detected in the external device. External device(s) may include, but are not limited to: MPCEs, mechanically linked relays/contactors, and safety modules.

**Failure to Danger:** a failure which delays or prevents a machine safety system from arresting dangerous machine motion.

**Final Switching Device (FSD):** the component of the machine's safety-related control system that interrupts the circuit to the machine primary control element (MPCE) when the output signal switching device (OSSD) goes to the OFF-state.

**FMEA (Failure Mode and Effect Analysis):** a testing procedure by which potential failure modes in a system are analyzed to determine their results or effects on the system. Component failure modes that produce either no effect or a Lockout condition are permitted; failures which cause an unsafe condition (a failure to danger) are not. Banner safety products are extensively FMEA tested.

**Forced-Guided Contacts:** relay contacts that are mechanically linked, so that when the relay coil is energized or de-energized, all of the linked contacts move together. If one set of contacts in the relay becomes immobilized, no other contact of the same relay will be able to move. The function of forced-guided contacts is to enable the safety circuit to check the status of the relay. Forced-guided contacts are also known as "positive-guided contacts," "captive contacts," "locked contacts," or "safety relays."

**Guarded Machine:** The machine whose point of operation is guarded by the safety light screen system.

**Hard Guard:** screens, bars, or other mechanical barriers affixed to the frame of the machine intended to prevent entry by personnel into the hazardous area(s) of a machine, while allowing the point of operation to be viewed. The maximum size of openings is determined by the applicable standard, such as Table O-10 of OSHA 29CFR1910.217, also called a "fixed barrier guard."

**Hazardous Area:** an area that poses an immediate or impending physical hazard.

**Hazard Point:** the closest reachable point of the hazardous area.

**Internal Lockout:** a Lockout condition that is due to an internal safety system problem. Generally, indicated by the red Status indicator LED (only) flashing. Requires the attention of a Qualified Person.

**Key Reset (Manual Reset):** a key-operated switch used to reset a safety light screen system to the ON state following a Lockout condition. Also refers to the act of using the switch to reset a safety system from a Latch condition.

**Latch Condition:** the response of the Safety Outputs (e.g., OSSDs) of a safety light screen system when an object equal to or greater than the diameter of the specified test piece enters the defined area. In a Latch condition, safety outputs simultaneously de-energize and open their contacts. The contacts are held (latched) open until the object is removed from the defined area and a manual reset is performed. A latching output is used most often in perimeter guarding applications. (See Trip Condition.)

**Lockout Condition:** a safety light screen system condition that is automatically attained in response to certain failure signals (an internal lockout). When a Lockout condition occurs, the safety light screen system's safety outputs turn OFF, and a manual reset is required to return the system to RUN mode.

**Machine Operator:** an individual who performs production work and who controls operation of the machine.

**Machine Primary Control Element (MPCE):** an electrically-powered element, external to the safety system, which directly controls the machine's normal operating motion in such a way that the element is last (in time) to operate when machine motion is either initiated or arrested.

**Minimum Object Sensitivity (MOS):** the minimum-diameter object that a safety light screen system can reliably detect. Objects of this diameter or greater will be detected anywhere in the defined area. A smaller object can pass undetected through the light if it passes exactly midway between two adjacent light beams. Also known as MODS (Minimum Object Detection Size). See also Specified Test Piece.

**Muting:** the automatic suspension of the safeguarding function of a safety device during a non-hazardous portion of the machine cycle.

**OFF State:** The state in which the output circuit is interrupted and does not permit the flow of current.

**ON State:** The state in which the output circuit is complete and permits the flow of current.

**OSHA (Occupational Safety and Health Administration):** a U.S. Federal agency, Division of the U.S. Department of Labor, that is responsible for the regulation of workplace safety.

**OSSD: Output Signal Switching Device.** The safety outputs that are used to initiate a stop signal.

**Pass-Through Hazard:** A situation that may exist when personnel pass through a safeguard (at which point the hazard stops or is removed), and then continue into the guarded area. At this point the safeguard may not be able to prevent an unexpected start or restart of the machine with personnel within the guarded area.

**Point of Operation:** the location of a machine where material or a workpiece is positioned and a machine function is performed upon it.

**Point-of-Operation Guarding:** safeguards, such as hard guards or safety light screens, which are designed to protect personnel from hazardous machine motion when close to the machine's point of operation.

**Qualified Person:** an individual who, by possession of a recognized degree or certificate of professional training, or by extensive knowledge, training, and experience, has successfully demonstrated the ability to solve problems relating to the subject matter and work. (See Designated Person.)

**Receiver:** the light-receiving component of a safety light screen system, consisting of a row of synchronized phototransistors. The receiver, together with the emitter (placed opposite), creates a "screen of light" called the defined area.

**Reset:** The use of a manually operated switch to restore the safety outputs to the ON state from a lockout or a Latch condition.

**Self-Checking (Circuitry):** a circuit with the capability to electronically verify that all of its own critical circuit components, along with their redundant backups, are operating properly. Banner safety light screen systems and safety modules are self-checking.

**Separation Distance (Safety Light Screen):** the minimum distance required to allow the machine's hazardous motion to stop completely, before a hand (or other object) can reach the nearest hazard point. Measured from the midpoint of the defined area to the nearest hazard point. Factors that influence minimum separation distance include the machine stop time, the light screen system response time, and the light screen minimum object detection size.

**Specified Test Piece:** an opaque object of sufficient size used to block a light beam to test the operation of a safety light screen system. When inserted into any part of the defined area, it will place a system into a Trip or Latch condition. Banner supplies specified test pieces with each system. See also Minimum Object Sensitivity.

**Supplemental Guarding:** additional safeguarding device(s) or hard guarding, used to prevent a person from reaching over, under, through or around the primary safeguard or otherwise accessing the guarded hazard.

**Test Piece:** an opaque object of sufficient size used to block a light beam to test the operation of a safety light screen system.

**Trip Condition:** the response of the safety outputs (e.g., OSSDs) of a safety light screen system when an object equal to or greater than the diameter of the specified test piece enters the defined area. In a Trip condition, the OSSDs simultaneously de-energize. A Trip condition clears (resets) automatically when the object is removed from the defined area. (See Latch Condition.)

**TUV (Technischer Überwachungsverein):** independent testing and certification organization providing EMC and product safety testing, certification, and quality management systems registration.

**UL (Underwriters Laboratory):** a third-party organization that tests products for compliance with appropriate standards, electrical codes, and safety codes. Compliance is indicated by the UL listing mark on the product.





The list of standards below is included as a convenience for users of this Banner product. Inclusion of these standards does not imply that the product complies specifically with any standard, other than those listed in the Specifications section of this manual.

## SOURCES

### **OSHA Documents**

**Superintendent of Documents  
Government Printing Office**  
P.O. Box 371954  
Pittsburgh, PA 15250-7954  
Tel: (202) 512-1800  
<http://www.osha.org>

### **ANSI Accredited Standards**

**American National Standards Institute (ANSI)**  
11 West 42nd Street  
New York, NY 10036  
Tel: (212) 642-4900  
<http://www.ansi.org>

### **B11 Documents**

**Safety Director  
The Association for Manufacturing  
Technology (AMT)**  
7901 Westpark Drive  
McLean, VA 22102  
Tel: (703) 893-2900  
<http://www.mfgtech.org>

### **RIA Documents**

**Robotics Industries Association (RIA)**  
900 Victors Way, P.O. Box 3724  
Ann Arbor, MI 48106  
Tel: (734) 994-6088  
<http://www.robotics.org>

### **NFPA Documents**

**National Fire Protection Association**  
1 Batterymarch Park  
P.O. Box 9101  
Quincy, MA 02269-9101  
Tel: (800) 344-3555  
<http://www.nfpa.org>

### **Alternate sources for these, plus ISO, IEC, EN, DIN, and BS Standards:**

**Global Engineering Documents**  
15 Inverness Way East  
Englewood, CO 80112-5704  
Tel: (800) 854-7179  
<http://www.global.ihs.com>

### **National Standards Systems Network (NSSN)**

25 West 43rd Street  
New York, NY 10036  
Tel: (212) 642-4980  
<http://www.nssn.com>

### **Document Center, Inc.**

111 Industrial Road, Suite 2  
Belmont, CA 94002  
Tel: (650) 591-7600  
<http://www.document-center.com>

## U.S. Application Standards

**ANSI B11.1** Mechanical Power Presses

**ANSI B11.2** Hydraulic Power Presses

**ANSI B11.3** Power Press Brakes

**ANSI B11.4** Shears

**ANSI B11.5** Iron Workers

**ANSI B11.6** Lathes

**ANSI B11.7** Cold Headers and Cold Formers

**ANSI B11.8** Drilling, Milling, and Boring

**ANSI B11.9** Grinding Machines

**ANSI B11.10** Metal Sawing Machines

**ANSI B11.11** Gear Cutting Machines

**ANSI B11.12** Roll Forming and Roll Bending  
Machines

**ANSI B11.13** Single- and Multiple-Spindle  
Automatic Bar and Chucking Machines

**ANSI B11.14** Coil Slitting Machines

**ANSI B11.15** Pipe, Tube, and Shape  
Bending Machines

**ANSI B11.16** Metal Powder Compacting  
Presses

**ANSI B11.17** Horizontal Extrusion Presses

**ANSI B11.18** Machinery and Machine  
Systems for the Processing of Coiled Strip,  
Sheet, and Plate

**ANSI B11.19** Performance Criteria for  
Safeguarding

**ANSI B11.20** Manufacturing Systems

**ANSI B11.21** Machine Tools Using Lasers

**ANSI B11.22** Numerically Controlled Turning  
Machines

**ANSI B11.23** Machining Centers

**ANSI B11.24** Transfer Machines

**ANSI B11.TR3** Risk Assessment

**ANSI/RIA R15.06** Safety Requirements for  
Industrial Robots and Robot Systems

**ANSI NFPA 79** Electrical Standard for  
Industrial Machinery

## OSHA Regulations

**OSHA Documents listed are part of:** Code  
of Federal Regulations Title 29, Parts 1900 to  
1910

**OSHA 29 CFR 1910.212** General Require-  
ments for (Guarding of) All Machines

**OSHA 29 CFR 1910.147** The Control of  
Hazardous Energy (lockout/tagout)

**OSHA 29 CFR 1910.217** (Guarding of)  
Mechanical Power Presses

## International/European Standards

**ISO/TR 12100-1 & -2 (EN 292-1 & -2)** Safety  
of Machinery – Basic Concepts, General  
Principles for Design

**ISO 13852 (EN 294)** Safety Distances  
. . . Upper Limbs

**ISO 13850 (EN 418)** Emergency Stop  
Devices, Functional Aspects – Principles for  
Design

**ISO/DIS 13851 (EN 574)** Two-Hand Control  
Devices – Functional Aspects – Principles for  
Design

**ISO 13853 (prEN 811)** Safety Distances  
. . . Lower Limbs

**ISO 13849-1 (EN 954-1)** Safety-Related  
Parts of Control Systems

**ISO/DIS 13855 (EN 999)** The Positioning of  
Protective Equipment in Respect to Approach  
Speeds of Parts of the Human Body

**ISO 14121 (EN 1050)** Principles of Risk  
Assessment

**ISO 14119 (EN 1088)** Interlocking Devices  
Associated with Guards – Principles for  
Design and Selection

**IEC/EN 60204-1** Electrical Equipment of  
Machines Part 1: General Requirements

**IEC/EN 61496** Electro-sensitive Protection  
Equipment

**IEC 60529** Degrees of Protection Provided by  
Enclosures

**IEC/EN 60947-5-1** Low Voltage Switchgear  
– Electromechanical Control Circuit Devices

**IEC/EN 60947-1** Low Voltage Switchgear  
– General Rules

**IEC 61508** Functional Safety

**IEC 62061** Machinery Functional Safety





**more sensors, more solutions**

**WARRANTY:** Banner Engineering Corp. warrants its products to be free from defects for one year. Banner Engineering Corp. will repair or replace, free of charge, any product of its manufacture found to be defective at the time it is returned to the factory during the warranty period. This warranty does not cover damage or liability for the improper application of Banner products. This warranty is in lieu of any other warranty either expressed or implied.

P/N 116390 rev. C