

THESE DRAWINGS ARE THE PROPERTY OF QUALTEK ELECTRONICS AND NOT TO BE REPRODUCED FOR OR COMMUNICATED TO A THIRD PARTY WITHOUT THE EXPRESS WRITTEN PERMISSION OF AN OFFICER OF QUALTEK ELECTRONICS.

Revision			
Rev.	Description	Date	Approved

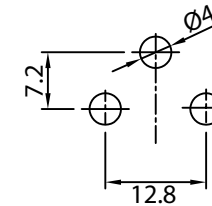
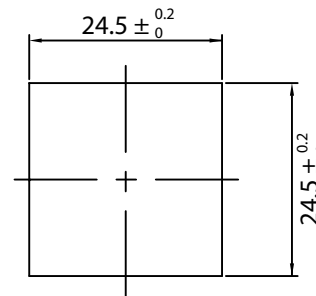
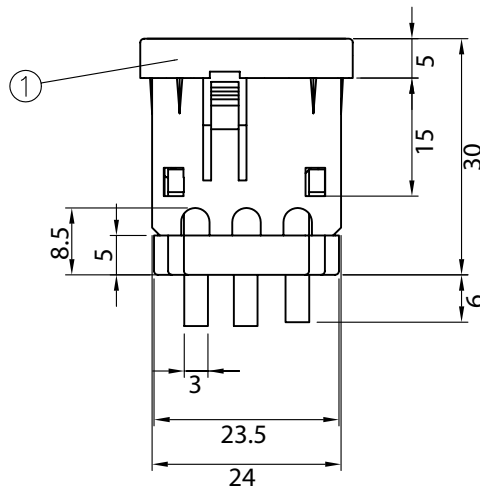
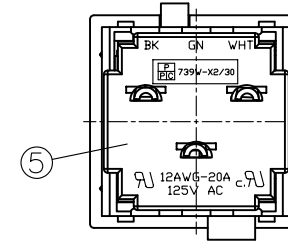
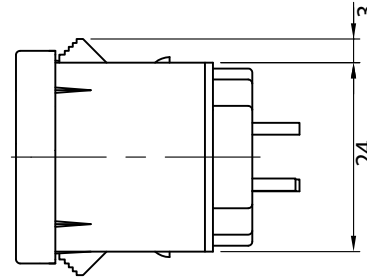
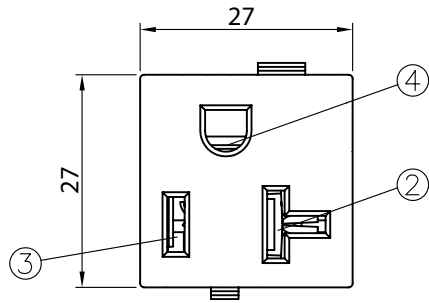

CONTROLLED

NOTE:

RATING: 20A 125V AC
 RECOMMENDED TO USE SOLID WIRE ONLY
 PANEL THICKNESS: 0.8~1.8mm
 APPROVALS: UL, cUL
 RoHS COMPLIANT

5	Cover back of the body, NYLON Black Color	1
4	Contact PIN Brass Strip t=0.7mm Tin Plated	1
3	Contact PIN Brass Strip t=0.7mm Tin Plated	1
2	Contact PIN Brass Strip t=0.7mm Tin Plated	1
1	Body Insulator NYLON Black Color	1

Dim range (mm)	Tolerance +/- (mm)	Qualtek Electronics Corp. PPC DIVISION		
0-1	0.15	Part Number: 739W-X2/30 RoHS Compliant		
1-6	0.20	Description: SNAP-IN 20 AMP T-SLOT RECEPTACLE		
6-18	0.30	UNIT: mm		
18-50	0.50	Drawn / Date	Checked / Date	Approved / Date
50-120	0.70	D.Povozhaev 05-14-07	05-14-07	JJH / 05-14-07
120-250	0.90			
250-500	1.20			