



Every part matters

EN

Datasheet

# RS PRO Class I DeskTop Power Supply

RS stock No: 144-0989

Output: 24V/5A





Every part matters

EN

---

## Index

1. General Description
2. Input Electrical Specification
3. Output Electrical Specification
4. Reliability Specification
5. Environmental Specification
6. Safety Specification
7. Mechanical Specification



## 1-0. General Description

The purpose of the document is to specify a Single phase AC input, single output switching power supply. This specification is suitable for: EA11012M Series

This product is AC to DC switching power transfer device, it can provide for a 24V, 5A max & 120W max DC output with constant voltage source.

This Specification defines the input, output, performance characteristics, environment, noise and safety requirement for a power supply.

## 2-0. Input Requirements

### 2-1. Input Voltage

Rated Voltage 100-240 Vac +/- 10% full range.

Normal line input 115Vac/60Hz, 230Vac/50Hz.

### 2-2. Input Frequency

47~63 Hz

### 2-3. Input Current

a. 1.5A(Max.) @ 115Vac input with full load.

b. 0.75A(Max.) @ 230Vac input with full load.

### 2-4. Energy saving standards:

2-4-0. Designed to meet the following standard :

DoE level VI

#### 2-4-1. Efficiency

Efficiency  $\geq$  88% ( avg. ) normal input & 25%, 50%, 75% ,100% of max output load

#### 2-4-2 No Load Power Consumption.

No Load Watt  $\cong$  0.21W at normal line input.

### 2-5. Configuration

2-wire AC input (Line , Neutral)

### 2-6. Input Fuse

The hot line side of the input shall have a fuse, rating (3.15A/250V)

2-7. Inrush Current

$\leq 60\text{A}$  at 110 Vac At cold start, maximum load.

$\leq 120\text{A}$  at 220 Vac At cold start, maximum load.

2-8. Line Regulation

This line regulation is less than  $\pm 1\%$ , of rated input voltage @ full load .

2-9. Hold Up Time

$\geq 10$  mSec., @ Normal line, with full load.

2-10. Rise Time

$\leq 50$  mSec.,@ 100-240VAC input, with full load from 10% to 90% of output voltage.

2-11. Turn-ON Time

The output voltage should rise to 90% of rated output voltage in less than 3 SEC. from AC apply to 110Vac start up.

2-12. Harmonic Standard and Power Factor

The adapter complied with IEC 61000-3-2 class D harmonic standard while input power over than 75W. The P.F. shall  $>0.95$  @100Vac input and  $>0.9$  @240Vac input.

3-0. Output Requirements

3-1. Output Voltage and Current

Output Voltage (Vdc)	Current Min.(A)	Current Max.(A)
+24V	0	5A

3-2. Load Regulation

Voltage (Vdc)	Tolerance (%)	Voltage range(Vdc)
+24V	+5/, -5	22.8V—25.2V

3-3. Dynamic Load Regulation

$\pm 5\%$  excursion for 50% - 100% or 100% - 50% load change of DC output at any frequency up to 1KHz(duty 50%)

### 3-4. Ripple & Noise

The power supply shall not exceed the following limits on the indicated voltage for 60Hz or 50Hz ripple, Switching frequency ripple and noise and dynamic load variations measured with a 20MHz bandwidth

Output	Ripple/Noise
+24V	1.5% max. of rated output voltage

Input condition : for rated voltage , Output condition : for max load

Ripple / Noise: 60Hz ripple + switching ripple and noise

Ripple & Noise are measured at the end of output cable which are added a 0.1uF ceramic capacitor and a 47uF electrolytic capacitor

### 3-5. Over Voltage Protection

150% Max. of rated voltage.

The output voltage shall be shutdown and latch-off when OVP occurred.

### 3-6. Over Current Protection

110%-150% of rated output current.

The adapter can withstand continuous short at DC output and no damage.

It will enter into normal condition if the fault condition is removed.

### 3-7. Stability

2% Max. at constant load with constant input (after 30 minutes of operation).

### 3-8. Temperature Rise

Less than 45°C on top/bottom case at normal AC input & 80% load of DC output at environment temperature 25°C .

### 3-9. Drop-out (Power Line Disturbance)

Output voltage shall remain within the specified regulation range, through the absence of a line input during 1/2 cycle, at full load and normal AC line input

### 3-10. Voltage Isolation

The DC ground will be isolated from the AC neutral and AC line.



#### 4-0. Reliability

##### 4-1. MTBF (MIL-HDBK-217F)

The power supply shall be designed and produced to have a mean time between failures (MTBF) of 100,000 hours at 25 degrees C

#### 5-0. Environment

##### 5-1 Temperature

- a. Operating : 0 to 40 °C
- b. Storage : -20 to 85 °C

##### 5-2 Humidity

- a. Operating : 10% to 90 %
- b. Storage: 5% to 90 %

##### 5-3 Altitude

From sea level to 5,000 Meter ( operation ) and 5,000 Meter ( non operation )

#### 6-0. Safety

##### 6-1. Hi-Pot Test

3000Vac 5mA 2 Sec between primary and secondary circuit

##### 6-2. Insulation Test

500Vdc, 3Sec. between primary and secondary circuit  
IR should  $\geq$  50 M $\Omega$ .

##### 6-3. Leakage Current

$\leq$  250uA at 240Vac/50 Hz

##### 6-4. Safety

UL, CUL, TUV/GS, CB, CE, FCC, RCM, ARGENTINA, CCC, PSE, CU, BSMI



6-5. EMS

Items	Specification	Reference
ESD	Contact: $\pm$ 4KV	IEC 61000-4-2
	Air: $\pm$ 8KV	
RS	Frequency: 80~1000MHz Field Strength: 3V/M , 80% AM(1KHz)	IEC 61000-4-3
EFT	1.0 KV on input AC power ports.	IEC 61000-4-4
SURGE	Line to Line: $\pm$ 1KV (peak)	IEC 61000-4-5

6-6. EMI

Comply with Standards
CISPR 32, EN 55032 Class B

7-0. Mechanical Characteristics

7-1. Physical Size : 137mm (L) \* 59 mm (W) \* 34 mm (H)

7-2. Enclosure material : 94V-0 minimum

7-3. Output Cable (Reference) : UL2464 #16

7-4. Vibration Test

The vibration frequencies are set at 20Hz, with total amplitude of 1.5mm  
Along the 3 directions namely X-Y-Z. The each direction should be vibrated  
for 60 minutes, after testing no abnormal electrical or mechanical should occur.

7-5. Drop Test (Referencing to CSA C22.2 No.950/UL1950/UL1310/EN60950)

Products shall be dropped from a height of 900 mm onto a horizontal surface  
consists of hardwood at 13mm thick, mounted on two layers of plywood each  
19mm to 20mm thick, all supported on a concrete or equivalent non-resilient  
floor. Upon conclusion of test, the equipment need not be operational.

7-6. Net Weight (Reference) : 450 g

客戶名稱 B009

版本	變更項目
1	

1

1

3.50 mm \*③ 3.50 mm

RS PRO RS Stock Number 144-0989

AC ADAPTER 电源适配器 电源供应器  
 MODEL 型号 型号: EA11012M-240  
 AC INPUT 输入 输入: 100-240V~2.0A, 50-60Hz  
 DC OUTPUT 输出 输出: 24V --- 5A

CAUTION 注意 注意  
 FOR INDOOR USE ONLY 室内产品使用 室内产品使用  
 I.T.E. USE ONLY

DATE CODE: 

17	18	19				1	2	3	4	5
1	2	3	4	5	6	7	8	9	0	

UL LISTED I.T.E. POWER SUPPLY 41TJ E209833  
 TUV FC CE  
 VI R33147  
 CCC S&E EAC RoHS  
 SGS-140450-EA  
 制造商: 翌胜电子股份有限公司  
 13121101133 C3 MADE IN CHINA 中国制造 中國製造

\*① 71.00 mm

2

2

\*② 41.00 mm

RS PRO RS Stock Number 144-0989

AC ADAPTER 电源适配器 电源供应器  
 MODEL 型号 型号: EA11012M-240  
 AC INPUT 输入 输入: 100-240V~2.0A, 50-60Hz  
 DC OUTPUT 输出 输出: 24V --- 5A

CAUTION 注意 注意  
 FOR INDOOR USE ONLY 室内产品使用 室内产品使用  
 I.T.E. USE ONLY

DATE CODE: 

17	18	19				1	2	3	4	5
1	2	3	4	5	6	7	8	9	0	

UL LISTED I.T.E. POWER SUPPLY 41TJ E209833  
 TUV SÜD FC CE  
 VI R33147  
 CCC S&E EAC RoHS  
 SGS-140450-EA  
 制造商: 翌胜电子股份有限公司  
 13121101133 C3 MADE IN CHINA 中国制造 中國製造

3

3



4

4

1. 材质: 50#压花底变色龙+雾面
2. 颜色: 黑底银字
3. 公差: ±0.1 / ±0.3
4. UL编号:
5. 出货检验报告 有 无
6. 包装方式:
7. 其他: \*标示为重点检验尺寸

吴江 巷泉包装材料有限公司 FAX:0512-63333167 TEL:0512-63330858	
品名 (DESCRIPTION)	料號 (PART NO.)
标签	3121101133
繪圖 (DRAWN BY:)	校稿 (CHECKED BY:)
彭美贞	

訂單號 (ORDER NUMBER)	核准 (APPROVED BY:)
單位 (UNIT)	日期 (DATE)
mm	2017/07/18
修訂 (REVISION)	主管 (CHARGE)
	程国华



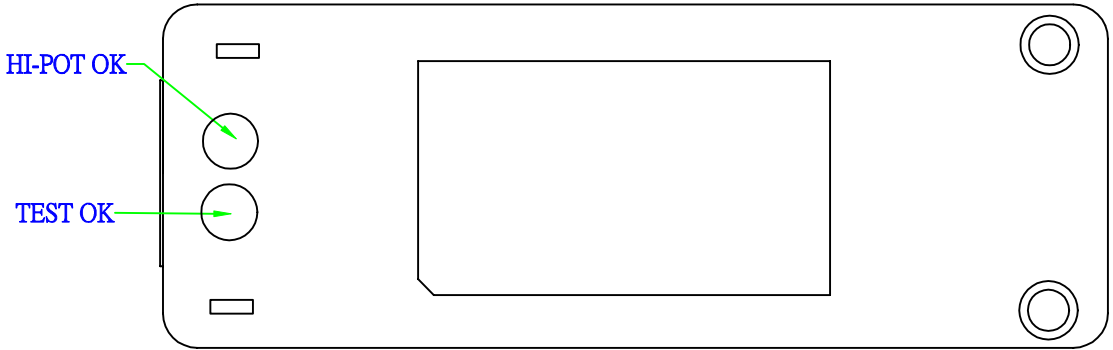
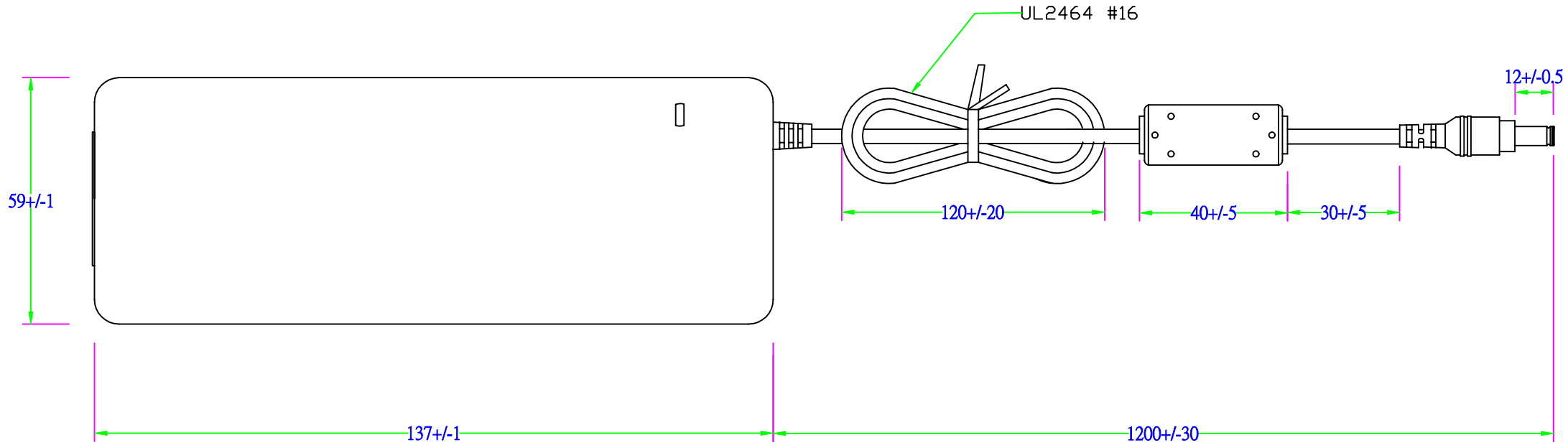

				APPROVED
MODEL	EA11012M(501)	UNIT	mm	DESIGNED
color	BLACK	SCALE		CHECK
cus.		DATE	2017-06-15	DRAWING L.J.YU

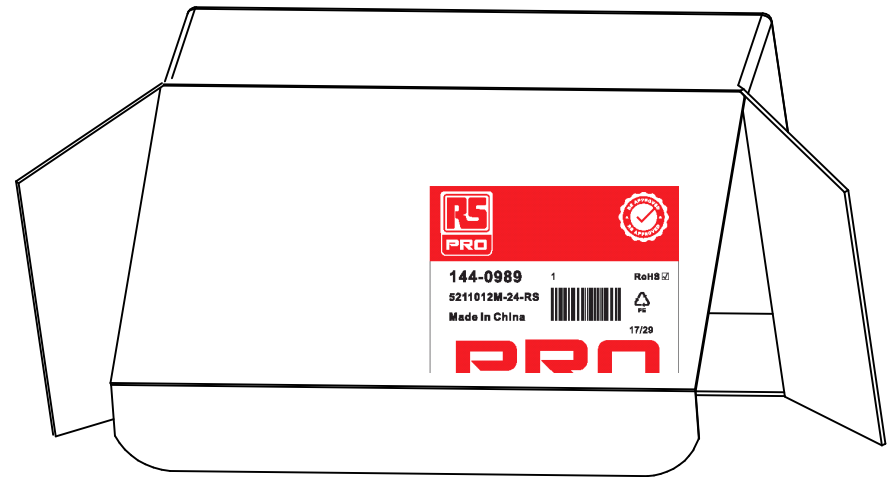
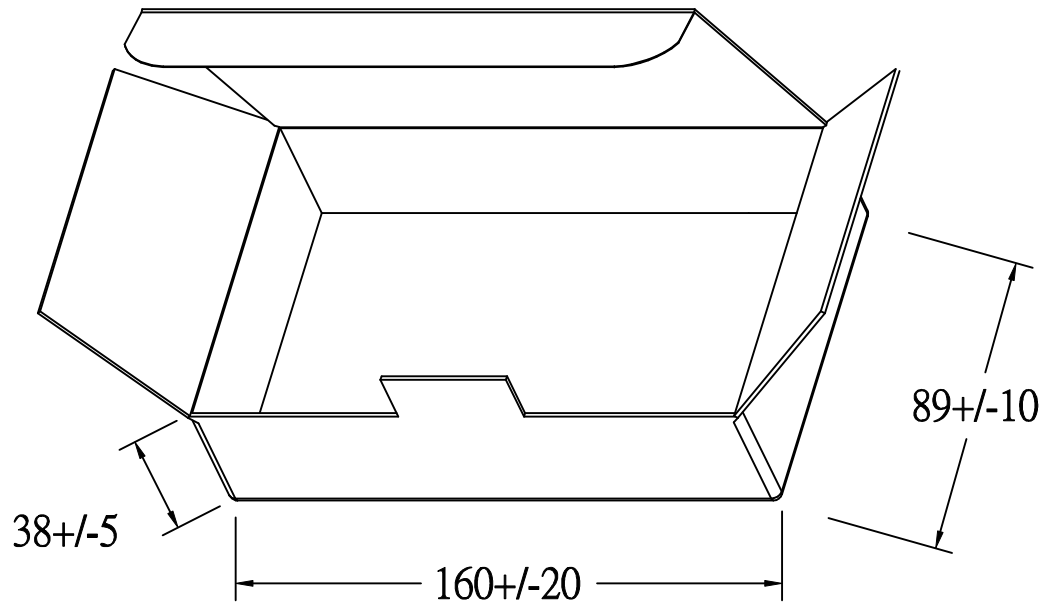

				APPROVED
MODEL	EA11012M(501)	UNIT	mm	DESIGNED
color		SCALE		CHECK
cus.		DATE	2017-08-11	DRAWING

客戶名稱	B009		
------	------	--	--

版本	變更項目
1	



Pantone 485C

备注：  
17/29=yy/ww  
(制造年/周期)

条码扫描内容为：1440989

4 1.材质: 铜版纸 2.颜色: 白底黑色+红色 3.公差: ± <sup>0.1</sup> / <sub>0.3</sub> 4.UL编号: 5.出货检验报告 <input type="checkbox"/> 有 <input type="checkbox"/> 无 6.条码类型: 128码 7.其他: *标示为重点检验尺寸	吴江 巷泉包装材料有限公司 FAX:0512-63333167 TEL:0512-63330858		訂單號 (ORDER NUMBER)	核準 (APPROVED BY:)  
	品名 (DESCRIPTION) 标签	料號 (PART NO.) 311110126	單位 (UNIT) mm	日期 (DATE) 2017/07/18
	繪圖 (DRAWN BY:) 彭美贞	校稿 (CHECKED BY:)  	修訂 (REVISION)	主管 (CHARGE) 程国华