

PART NUMBER	ITEM ① BODY	ITEM ② SLIDER	ITEM ③ CONTACT	ITEM ④ INSULATOR	ITEM ⑤ RETENTION SPRINGS	ITEM ⑥ COUPLING NUT	ITEM ⑦ CRIMP SLEEVE
142-1404-001	BRASS GOLD PL .00001 MIN OVER NICKEL PL .00005 MIN OVER COPPER PL .00005 MIN	BRASS NICKEL PL .0001 MIN OVER COPPER PL .00005 MIN	BERYLLIUM COPPER GOLD PL .00005 MIN OVER NICKEL PL .00005 MIN OVER COPPER PL .00005 MIN	TEFLON	BERYLLIUM COPPER UNPLATED	BERYLLIUM COPPER NICKEL PL .0001 MIN OVER COPPER PL .00005 MIN	COPPER NICKEL PL .0001 MIN OVER COPPER PL .00005 MIN

DRAWING NO. C - 142-1404-001/010	
0	REVISIONS
ENGINEERING RELEASE	
1	03-02-04 T A R ECN 49130

## INSTRUCTIONS FOR USE:

- WITH SLIDER AT THE ENGAGED POSITION, THE CONNECTOR FUNCTIONS LIKE A STANDARD SMA CONNECTOR. TIGHTEN (SPIN) THE KNURLED COUPLING NUT BY HAND TO OBTAIN FULL MATING ENGAGEMENT OR DISENGAGEMENT.
- QUICK CONNECT:
  - WITH SLIDER AT THE DISENGAGED POSITION, SLIDE THE CABLED CONNECTOR ONTO AN SMA JACK RECEPTACLE, OVER THE JACK THREADS BY PUSHING ON THE BACK OF THE KNURLED NUT.
  - ENGAGE THE SLIDER WHILE MAINTAINING LIGHT FORWARD PRESSURE ON THE NUT. THIS ACTION IS DONE BY SLIPPING YOUR FINGERS FROM THE NUT TO THE SLIDER IN ONE MOTION.
  - ONCE THE SLIDER IS ENGAGED THE KNURLED NUT CAN BE TURNED 1 TURN OR LESS TO OBTAIN FULL ENGAGEMENT SMA PERFORMANCE.
  - DISENGAGE THE CONNECTOR BY FIRST LOOSENING THE KNURLED NUT A PARTIAL TURN. THEN DISENGAGE THE SLIDER AND REMOVE THE CONNECTOR.

## CAUTION:

- THIS SMA PLUG CONNECTOR IS DESIGNED FOR HIGH DURABILITY AND LONG LIFE IN TEST APPLICATIONS. HOWEVER, IT IS DESIGNED FOR LIMITED MATINGS WITH A SINGLE JACK RECEPTACLE. AN SMA JACK RECEPTACLE MAY EXPERIENCE THREAD PLATING WEAR AFTER MANY ENGAGEMENTS.

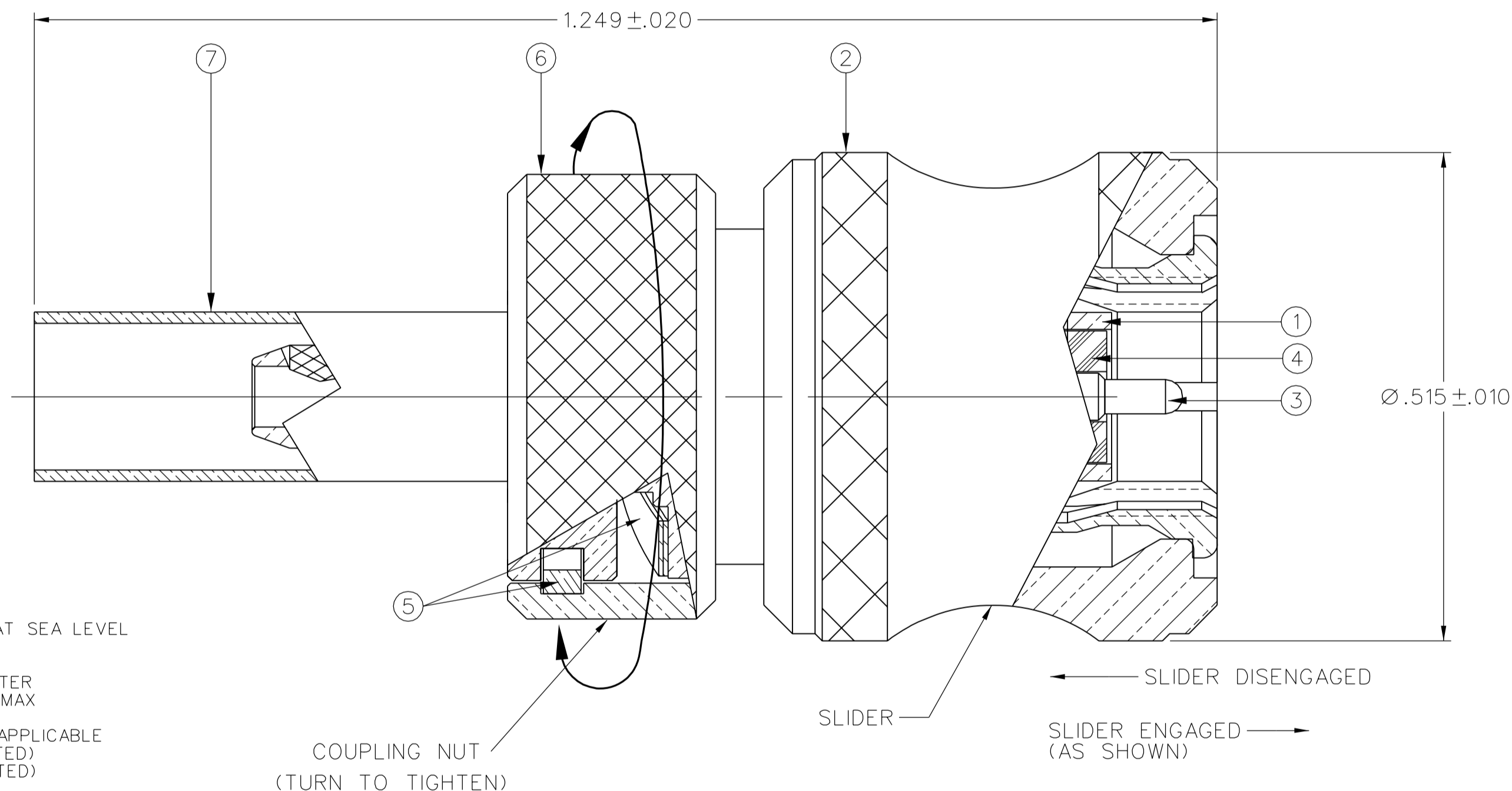

### NOTES:

#### 1. SPECIFICATIONS:

IMPEDANCE: 50 OHMS  
 FREQUENCY RANGE: 0-12.4 GHz  
 VSWR: 1.15+.02 F MAX (F IN GHz)  
 WORKING VOLTAGE: 250 VRMS MAX AT SEA LEVEL  
 DIELECTRIC WITHSTANDING VOLTAGE: 750 VRMS MIN AT SEA LEVEL  
 INSULATION RESISTANCE: 5000 MEGOHM MIN  
 CONTACT RESISTANCE:  
 CENTER CONTACT - INITIAL 3.0 MILLIOHM MAX, AFTER ENVIRONMENTAL 4.0 MILLIOHM MAX  
 OUTER CONDUCTOR - INITIAL 2.0 MILLIOHM MAX AFTER ENVIRONMENTAL NOT APPLICABLE  
 BODY TO CABLE - 0.5 MILLIOHM MAX (GOLD PLATED) 5.0 MILLIOHM MAX (NICKEL PLATED)  
 CORONA LEVEL: 190 VOLTS MIN AT 70,000 FEET  
 INSERTION LOSS: .06 √ F dB MAX (F IN GHz) AT 6 GHz  
 RF LEAKAGE: -60 DB MIN AT 2.5 GHz  
 RF HIGH POTENTIAL WITHSTANDING VOLTAGE: 500 VRMS MIN AT 4 AND 7 MHz

#### MECHANICAL:

ENGAGE/DISENGAGE TORQUE: 2 INCH-POUNDS MAX  
 MATING TORQUE: 7-10 INCH POUNDS  
 COUPLING PROOF TORQUE: 15 INCH-POUNDS MIN  
 COUPLING NUT RETENTION: 60 LBS MIN  
 CONTACT RETENTION: 6 LBS MIN  
 CABLE ACCEPTABILITY: RG 316/U DOUBLE SHIELDED  
 RG 188/U DOUBLE SHIELDED  
 CABLE HEX CRIMP SIZE: .151  
 CABLE RETENTION: 20 LBS MIN AXIAL FORCE  
 DURABILITY: 500 CYCLES MIN

#### ENVIRONMENTAL:

(MEETS OR EXCEEDS THE APPLICABLE PARAGRAPH OF MIL-PRF-39012)  
 THERMAL SHOCK: MIL-STD-202, METHOD 107, CONDITION B, EXCEPT 85° C HIGH TEMP  
 OPERATING TEMPERATURE: -65° C TO 165° C  
 CORROSION: MIL-STD-202, METHOD 101, CONDITION B  
 SHOCK: MIL-STD-202, METHOD 213, CONDITION I  
 VIBRATION: MIL-STD-202, METHOD 204, CONDITION D  
 MOISTURE RESISTANCE: MIL-STD-202, METHOD 106

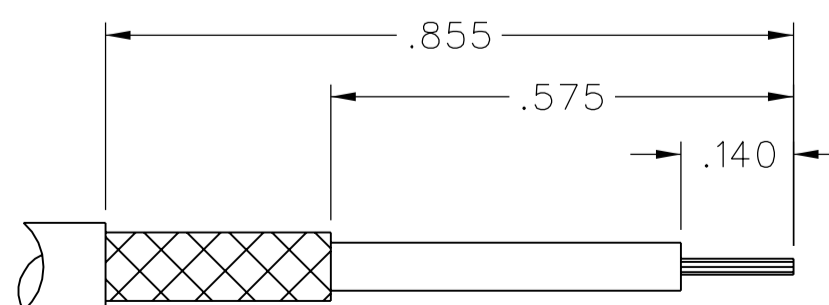

## CABLE STRIP DIMENSIONS

4:1

TOLERANCE UNLESS OTHERWISE SPECIFIED	DRAWN BY T.A.Kari	DATE 12-22-03
DECIMALS	CHECKED BY	DATE
.XX		
.XXX	APPROVED BY	DATE
MATL		
FINISH	RELEASE DATE	12-22-03
	U/M	INCH
		SCALE 8:1



Cinch Connectivity Solutions  
 P.O. Box 1732  
 Waseca, MN 56093  
 1-800-247-8256

TITLE  
 STRAIGHT CABLED PLUG  
 QUICK CONNECT COUPLING  
 SMA, RG 316DS, CRIMP TYPE

SHEET 1 OF 2  
 DRAWING NO. C - 142-1404-001/010

## CUSTOMER DRAWING

THIS DRAWING TO BE INTERPRETED PER ASME Y 14.5M - 1994

"μSTATION"

## COMPANY CONFIDENTIAL