

# LMC100

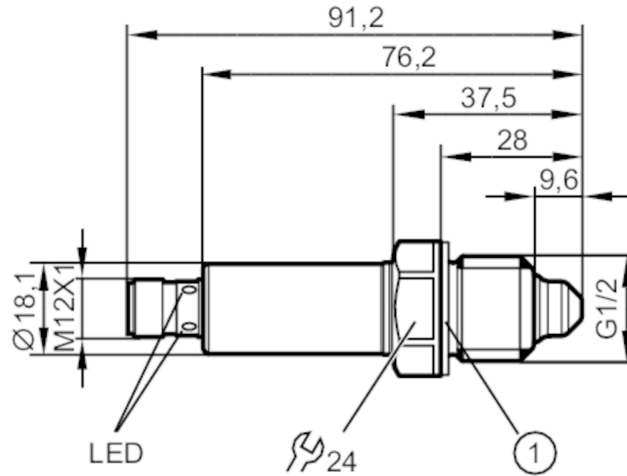

## Sensor for point level detection

LMFCE-B12E-QSKG-0/US



1 sealing



Application	
Media	water; water-based media; oils; oil-based media; Coolants; powder
Cannot be used for	See the operating instructions, chapter "Function and features".
Medium temperature [°C]	-25...100
Probe length [mm]	28
Tank pressure [bar]	-1...40
MAWP (for applications according to CRN) [bar]	40
oil	
Medium temperature [°C]	-25...100
Electrical data	
Operating voltage [V]	18...30 DC
Current consumption [mA]	< 35
Protection class	III
Reverse polarity protection	yes
Inputs / outputs	
Number of inputs and outputs	Number of digital outputs: 2

# LMC100



## Sensor for point level detection

LMFCE-B12E-QSKG-0/US

Outputs		
Total number of outputs		2
Output signal		switching signal; IO-Link
Electrical design		PNP/NPN
Number of digital outputs		2
Output function		normally open / closed; (configurable)
Max. voltage drop switching output DC	[V]	2.5
Permanent current rating of switching output DC	[mA]	50; (100 (...60 °C))
Short-circuit protection		yes
Type of short-circuit protection		thermal, pulsed
Overload protection		yes
Measuring/setting range		
Factory setting		water; water-based media
Reaction times		
Response time	[s]	< 0.5
Interfaces		
Communication interface		IO-Link
Transmission type		COM2 (38,4 kBaud)
IO-Link revision		1.1
SDCI standard		IEC 61131-9
IO-Link device ID		0x0002A2
Profiles		Smart Sensor: Process Data Variable; Device Identification, Device Diagnosis
SIO mode		yes
Required master port class		A
Process data analogue		1
Process data binary		2
Min. process cycle time	[ms]	2.3
Operating conditions		
Ambient temperature	[°C]	-25...85
Storage temperature	[°C]	-40...85
Protection		IP 68; IP 69K; (7 days / 1 m water depth / 0.1 bar: IP 68)
Tests / approvals		
EMC	DIN EN 61000-6-2	
	DIN EN 61000-6-3	: closed tanks
	DIN EN 61000-6-4	: open tanks
Shock resistance	DIN EN 60068-2-27	50 g (11 ms)
Vibration resistance	DIN EN 60068-2-6	20 g (10...2000 Hz)
MTTF	[years]	534
UL approval	UL approval number	H003

# LMC100



## Sensor for point level detection

LMFCE-B12E-QSKG-0/US

Mechanical data	
Weight [g]	149
Dimensions [mm]	Ø 18.1 / L = 76.2
Material	stainless steel (1.4404 / 316L); PEEK; PEI; FKM
Materials (wetted parts)	stainless steel (1.4404 / 316L); PEEK; FKM
Process connection	G 1/2 external thread

Displays / operating elements		
Display	Switching status	LEDs, yellow
	operating status	LEDs, green

Remarks	
Pack quantity	1 pcs.

### Electrical connection

Connector: 1 x M12; Contacts: gold-plated



### Connection

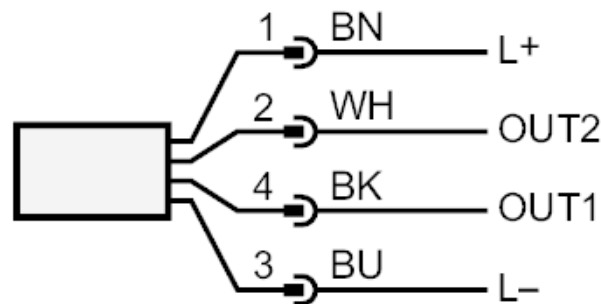

- OUT1: Switching output IO-Link  
OUT2: Switching output  
Colours to DIN EN 60947-5-2  
Core colors :
- BK = black  
BN = brown  
BU = blue  
WH = white