

PART NUMBER	ITEM ① BODY	ITEM ② NUT	ITEM ③ CONTACT	ITEM ④ INSULATOR	ITEM ⑤ RETENTION SPRING	ITEM ⑥ CRIMP SLEEVE	ITEM ⑦ GASKET	ITEM ⑧ HEAT SHRINK
141-0407-011	STAINLESS STEEL GOLD PL .00001 MIN OVER NICKEL PL .00005 MIN OVER	STAINLESS STEEL GOLD PL .00001 MIN OVER NICKEL PL .00005 MIN OVER	BRASS GOLD PL .00005 MIN OVER NICKEL PL .00005 MIN OVER COPPER PL .00005 MIN	TEFLON	BERYLLIUM COPPER UNPLATED	COPPER GOLD PL .00001 MIN OVER NICKEL PL .00005 MIN OVER COPPER PL .00005 MIN	SILICONE RUBBER	POLYOLEFIN COLOR: BLACK
141-0407-012	STAINLESS STEEL PASSIVATED	STAINLESS STEEL PASSIVATED	BRASS GOLD PL .00005 MIN OVER NICKEL PL .00005 MIN OVER COPPER PL .00005 MIN	TEFLON	BERYLLIUM COPPER UNPLATED	COPPER NICKEL PL .0001 MIN OVER COPPER PL .00005 MIN	SILICONE RUBBER	POLYOLEFIN COLOR: BLACK

DRAWING NO. C - 141-0407-011/020	
0 REVISIONS	
ENGINEERING RELEASE	
1	6-17-92 R H T R J H E M 6-30-92 ECO 41116
ADDED: ITEM 8 HEAT SHRINK	
2	10-6-92 R H T R J H E M 10-29-92 ECO 41315
VERSION UPDATE	
2a	9-14-94 R H C N T A K J B P A H ECN 42724
VERSION UPDATE	
* REVISION NUMBER FOLLOWED BY AN ALPHA *	
* CHARACTER INDICATES DRAWING CLARIFI-	
* CATION OR PART NUMBER ADDITION ONLY. *	
2b	2-1-95 R H C N T A K J B P A H ECN 43191
GRAPHICS & VERSION UPDATE	
3	12-12-05 P A T S B D W 5-12-06 ECN 50048
VERSION UPDATE	
* REVISION NUMBER FOLLOWED BY AN ALPHA *	
* CHARACTER INDICATES DRAWING CLARIFI-	
* CATION OR PART NUMBER ADDITION ONLY. *	
3a	5-26-06 P A T S B D W 6-20-06 ECN 50463
UPDATED VIEWS	
4	11-5-08 P A T R J B T M J U C N 11-10-08 ECN 51707

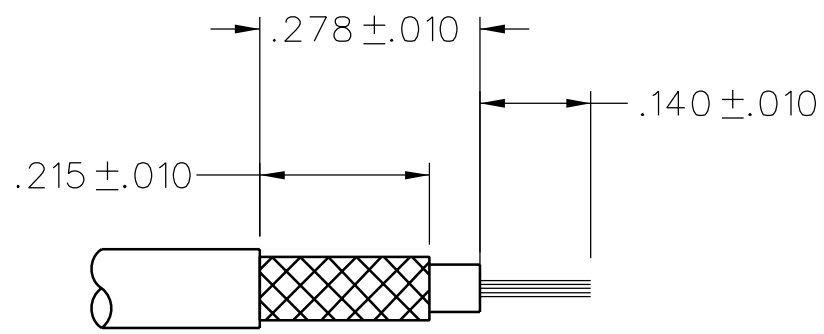
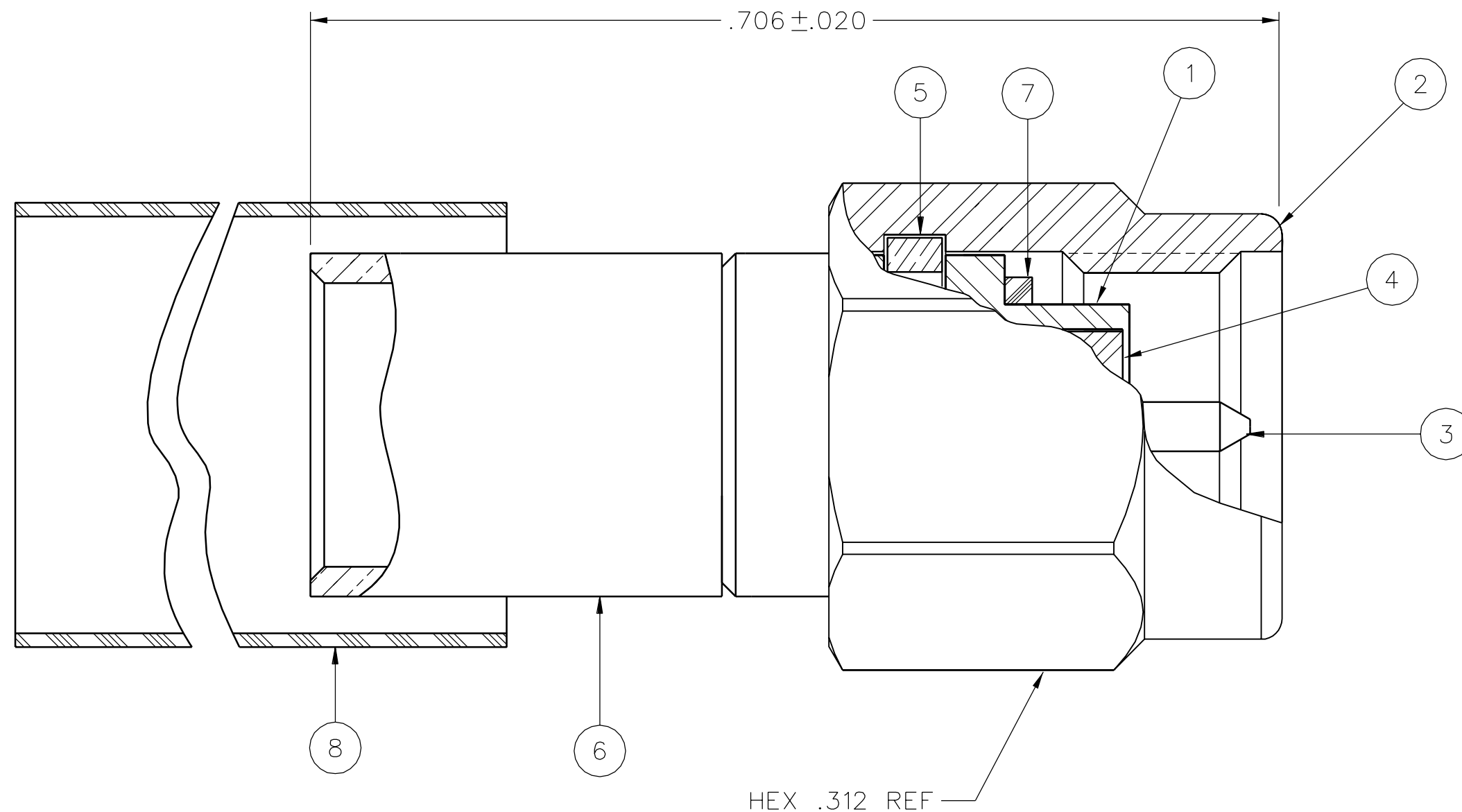
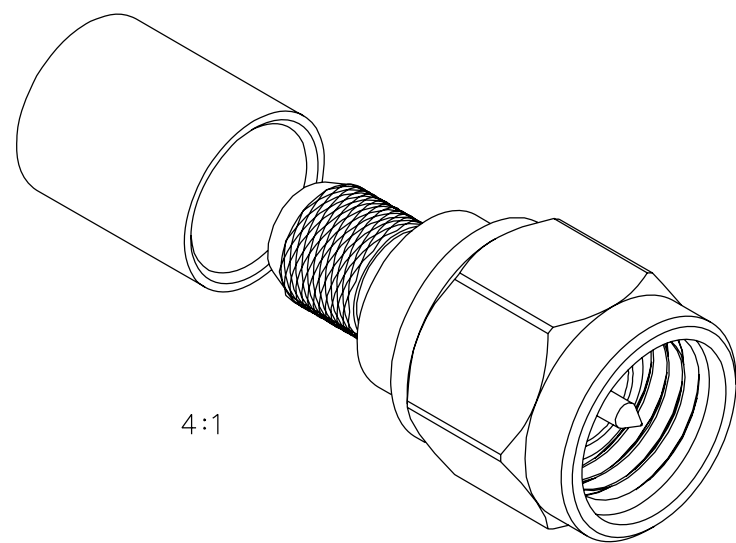

CABLE STRIP DIMENSIONS

NOTES:

1. SPECIFICATIONS:

IMPEDANCE: 50 OHMS
 FREQUENCY RANGE: 0-12.4 GHz
 VSWR: 1.15+.01 F MAX (F IN GHz)
 WORKING VOLTAGE: 335 VRMS MAX AT SEA LEVEL
 DIELECTRIC WITHSTANDING VOLTAGE: 1000 VRMS MIN AT SEA LEVEL
 INSULATION RESISTANCE: 5000 MEGOHM MIN
 CONTACT RESISTANCE:
 CENTER CONTACT - INITIAL 3.0 MILLIOHM MAX, AFTER ENVIRONMENTAL 4.0 MILLIOHM MAX
 OUTER CONDUCTOR - INITIAL 2.0 MILLIOHM MAX AFTER ENVIRONMENTAL NOT APPLICABLE
 BODY TO CABLE - 0.5 MILLIOHM MAX (GOLD PLATED) 5.0 MILLIOHM MAX (PASSIVATED)
 CORONA LEVEL: 250 VOLTS MIN AT 70,000 FEET
 INSERTION LOSS: .06V/F MAX (F IN GHz) AT 6 GHz
 RF LEAKAGE: -60 DB MIN AT 2.5 GHz
 RF HIGH POTENTIAL WITHSTANDING VOLTAGE: 670 VRMS MIN AT 4 AND 7 MHz

MECHANICAL:

ENGAGE/DISENGAGE TORQUE: 2 IN-LBS MAX
 MATING TORQUE: 7-10 IN-LBS
 COUPLING PROOF TORQUE: 15 IN-LBS MIN
 COUPLING NUT RETENTION: 60 LBS MIN
 CONTACT RETENTION: 6 LBS MIN AXIAL FORCE
 CABLE ACCEPTABILITY: RG 58/U, RG 141/U, RG 303/U,
 CABLE HEX CRIMP SIZE: .213
 CONTACT CRIMP TOOL: MIL M225201/1-01
 CABLE RETENTION: 40 LBS MIN AXIAL FORCE
 DURABILITY: 500 CYCLES MIN

ENVIRONMENTAL:

(MEETS OR EXCEEDS THE APPLICABLE PARAGRAPH OF MIL-PRF-39012)
 THERMAL SHOCK: MIL-STD-202, METHOD 107, CONDITION B, EXCEPT 85°C HIGH TEMP
 OPERATING TEMPERATURE: -65°C TO 165°C
 CORROSION: MIL-STD-202, METHOD 101, CONDITION B
 SHOCK: MIL-STD-202, METHOD 213, CONDITION I
 VIBRATION: MIL-STD-202, METHOD 204, CONDITION D
 MOISTURE RESISTANCE: MIL-STD-202, METHOD 106

CUSTOMER DRAWING

THIS DRAWING TO BE INTERPRETED PER ASME Y 14.5M - 1994

"μ STATION"

COMPANY CONFIDENTIAL

TOLERANCE UNLESS OTHERWISE SPECIFIED	DRAWN BY TAK	DATE 3-9-92	 Cinch <small>CONNECTIVITY SOLUTIONS</small> <small>a bel group</small>	Cinch Connectivity Solutions P.O. Box 1732 Waseca, MN 56093 1-800-247-8256
DECIMALS _____ mm _____	CHECKED BY	DATE		TITLE PLUG ASSEMBLY, STRAIGHT CABLED SMA, RG 58
.XX _____	APPROVED BY RJB/TAK	DATE 6-26-92	SHEET 2 OF 2	DRAWING NO. C - 141-0407-011/020
.XXX _____	RELEASE DATE 6-30-92	SCALE 10:1		
MATL _____	U/M INCH			
FINISH _____				