

SERIES 70 VALVES

This is Metal Work's full range. Available in three sizes: 1/8", 1/4", 3/8", 1/2". Three versions: 3/2; 5/2; 5/3, four different types of actuation (mechanical, manual, pneumatic and electric).

Series 70 valves can be used for a wide range of applications as they can be mounted in line, on the wall, on the cylinder using a special bracket, or in series on a multiple or manifold base.

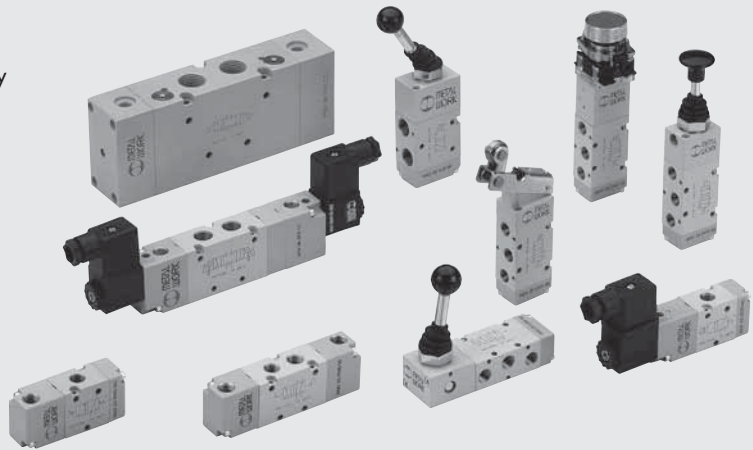

TECHNICAL DATA	1/8" NPT	1/4" NPT	3/8" NPT	1/2" NPT	
Thread on the valve ports	1/8" NPT	1/4" NPT	3/8" NPT	1/2" NPT	
Operating pressure:					
• monostable	psi	36.3 to 145			
• bistable	psi	14.5 to 145			
• asserved	psi	vacuum to 145			
Minimum pilot pressure	psi	36.3			
Operating temperature range	°F	14 to +140			
Nominal diameter	in	0.20	0.30	0.52	0.59
Conductance C	scfm/psi	0.30	0.65	1.23	2.37
Critical ratio b	psi/psi	0.32	0.27	0.32	0.43
Flow rate at 87 psi ΔP 7.25 psi	scfm	14	26.5	55.2	113
Flow rate at 87 psi ΔP 14.5 psi	scfm	19.5 Cv 0.55	39 Cv 1.1	75 Cv 2.1	163 Cv 4.6
Installation	In any position (vertical assembly is not recommended for bistable valves subjected to vibration)				
Fluid	Filtered air without lubrication; lubrication, if used, must be continuous				
Recommended lubricant	ISO and UNI FD 22				
Maximum coil nut torque	lbf ft	0.74			
Compatibility with oils	Please refer to page 5-4 of the technical documentation				

COMPONENTS

- ① VALVE BODY: Aluminium
- ② CONTROL/END CAP: plastic
- ③ SPOOL: chemically nickel-plated aluminium
- ④ DISTANCE PLATES: plastic
- ⑤ GASKETS: NBR
- ⑥ PISTONS: Hostaform®
- ⑦ PISTON GASKET: NBR
- ⑧ FILTER: sintered bronze
- ⑨ SPRINGS: special steel
- ⑩ OPERATOR: Brass pipe - Stainless steel core

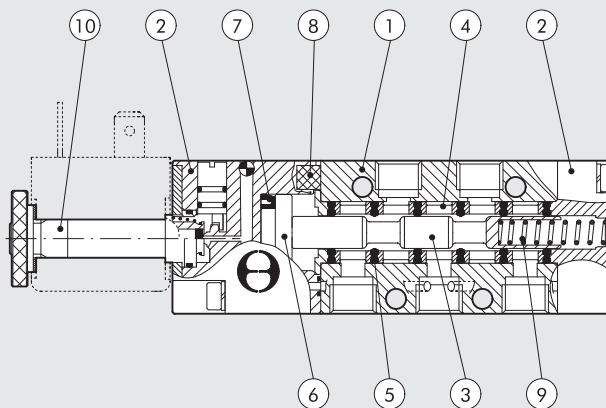

FLOW CHARTS

VALVES SERIES 70, 1/8"

Flow rates

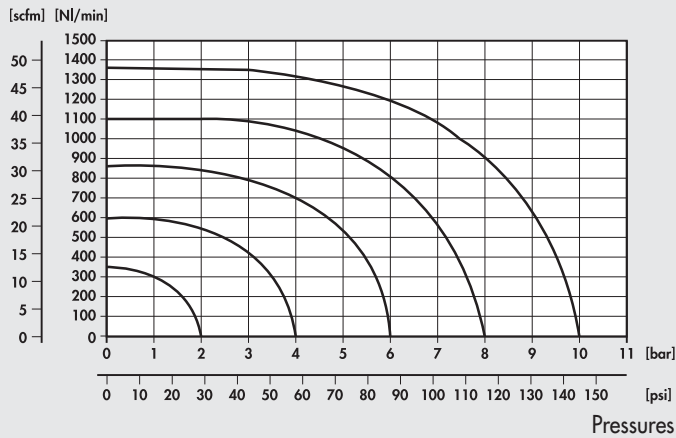

VALVES SERIES 70, 1/4"

Flow rates

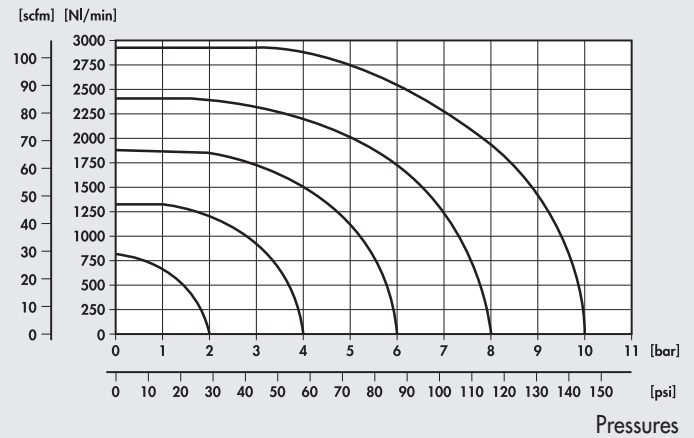

VALVES SERIES 70, 3/8"

Flow rates

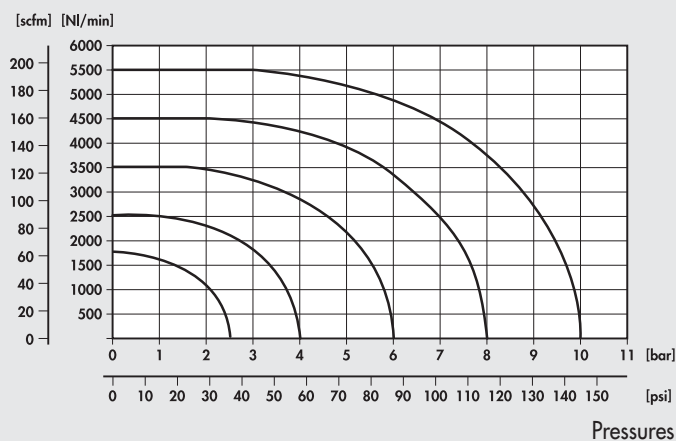

VALVES SERIES 70, 1/2"

Flow rates

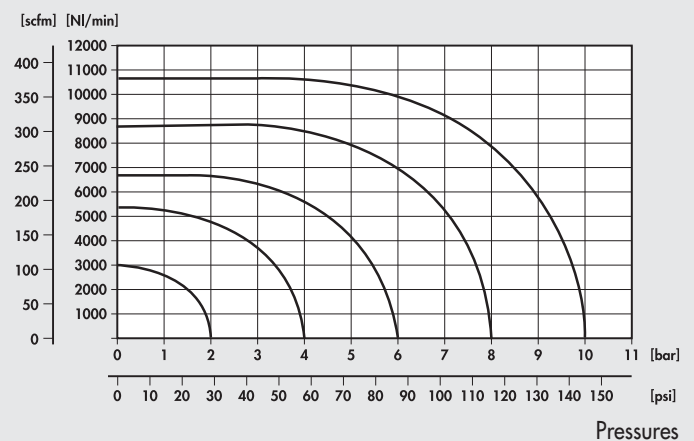

NOTES

Blank area for notes.

SERIES 70 VALVES, HAND OPERATED

TECHNICAL DATA	1/8" NPT	1/4" NPT	1/2" NPT	
Operating pressure range:				
• version with direct control	psi	Vacuum to 145		
• pilot-assisted version	psi	36.3 to 145		
Operating temperature range	°F	14 to + 140		
Nominal diameter	in	0.20	0.30	0.59
Conductance C	scfm/psi	0.30	0.65	2.37
Critical ratio b	psi/psi	0.32	0.27	0.43
Flow rate at 87 psi ΔP 7.25 psi	scfm	14	26.5	113
Flow rate at 87 psi ΔP 14.5 psi	scfm	19.5	39	163
		Cv 0.55	Cv 1.1	Cv 4.6

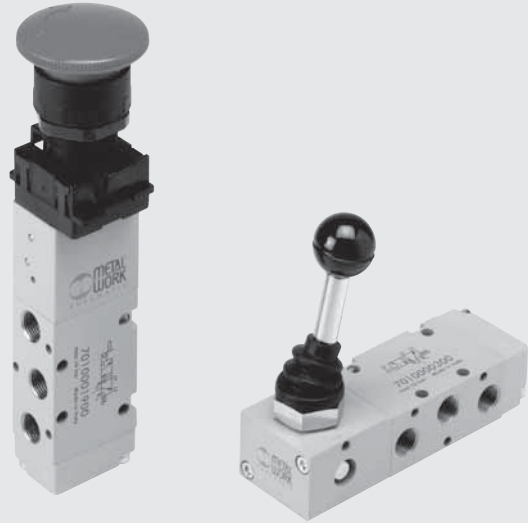

KEY TO CODES

M A V	2	3	P P	S	N C	U
FAMILY	DIMENSIONS	FUNCTION	OPERATORS 14	RESETTING (12)	FURTHER DETAILS	THREAD
MAV manual valves	2 1/8"	3 3/2	PP drawer	A pneumatic/ mechanical springs*	NC normally closed	U NPT
	3 1/4"	5 5/2	VL axial lever	S mechanical springs	NO normally open	
	4 1/2"	6 5/3	LE 90° lever	B bistable	OO no indication	
		8 2 x 3/2	BRE arranged for manual panel actuators	D differential	CC closed centres	
				O stable for 5/3	OC open centres	
					PC pressure centres	

*on demand

VALVES SERIES 70, HAND OPERATED, 1/8" NPT

90° LEVER 3/2 1/8" NPT

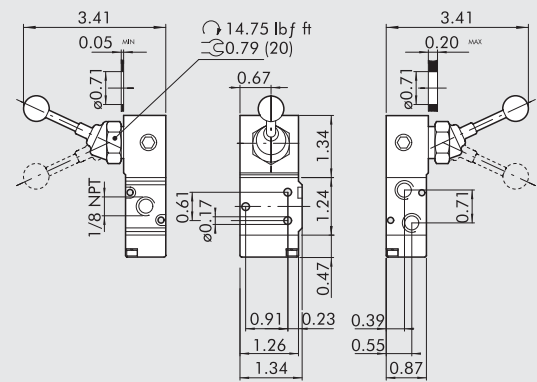

Symbol	Code	Abbrev.	Weight [lb]
	7010000100U	MAV 23 LES NC U	0.370
	7010000200U	MAV 23 LEB OO U	0.377

90° LEVER 3/2 1/8" NPT

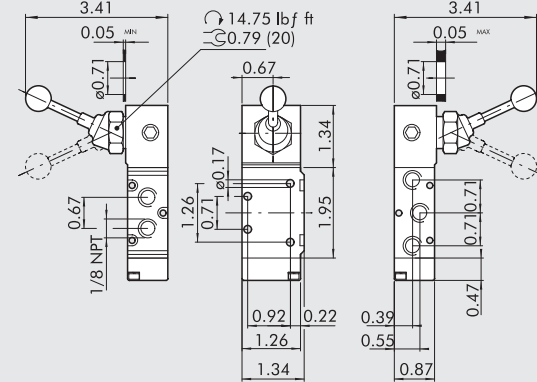

Symbol	Code	Abbrev.	Weight [lb]
	7010000300U	MAV 25 LES OO U	0.427
	7010000400U	MAV 25 LEB OO U	0.432

FRONT LEVER 3/2, 1/8" NPT

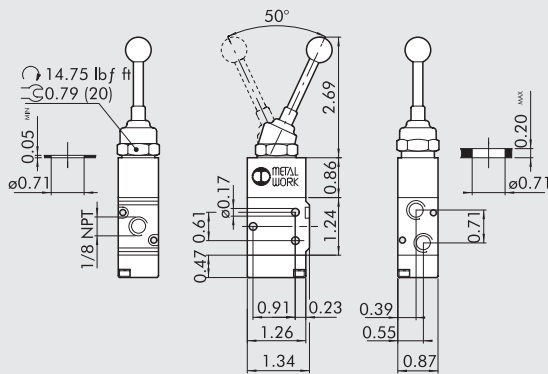

Symbol	Code	Abbrev.	Weight [lb]
	7010001400U	MAV 23 VLB OO U	0.287

FRONT LEVER 5/2, 1/8" NPT

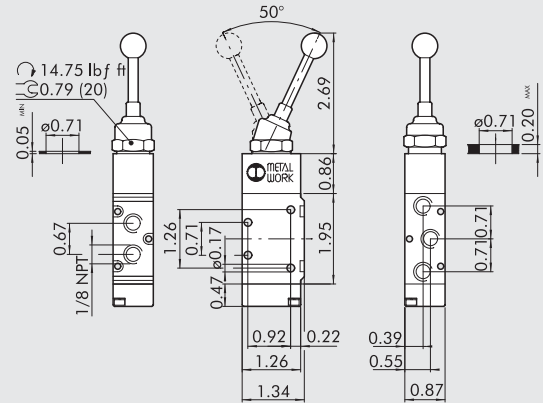

Symbol	Code	Abbrev.	Weight [lb]
	7010001700U	MAV 25 VLB OO U	0.344

ANGULAR LEVER 5/3, 1/8" NPT

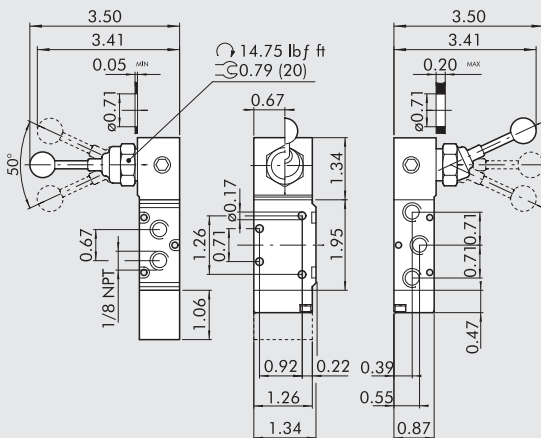

Symbol	Code	Abbrev.	Weight [lb]
	7010001000U	MAV 26 LES CC U	0.534
	7010000900U	MAV 26 LES OC U	0.534
	7010001100U	MAV 26 LES PC U	0.534
	7010000500U	MAV 26 LEO CC U	0.428
	7010000600U	MAV 26 LEO OC U	0.428
	7010000700U	MAV 26 LEO PC U	0.428

NOTES

DRAWER 3/2, 1/8" NPT

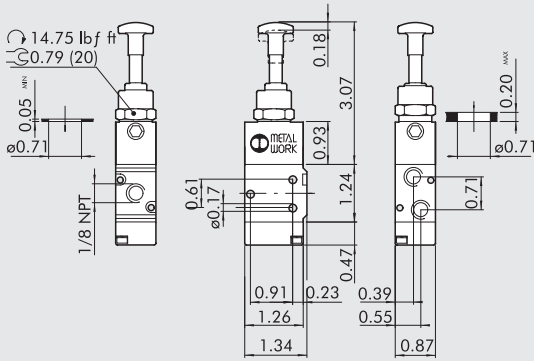

Symbol	Code	Abbrev.	Weight [lb]
	7010001300U	MAV 23 PPB OO U	0.296
	7010001200U	MAV 23 PPS NC U	0.296

DRAWER 5/2, 1/8" NPT

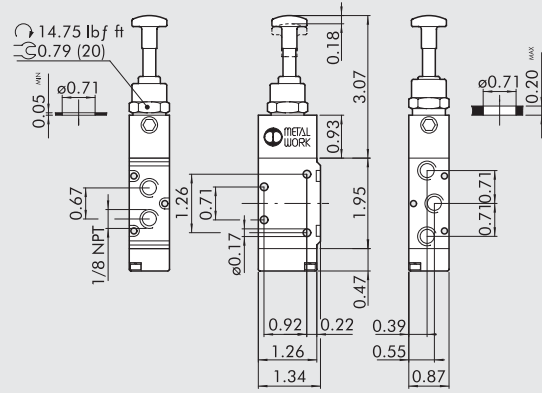

Symbol	Code	Abbrev.	Weight [lb]
	7010001600U	MAV 25 PPB OO U	0.353
	7010001500U	MAV 25 PPS OO U	0.353

PILOT-ASSISTED PLUNGER 3/2 1/8" NPT FOR PANEL ACTUATORS

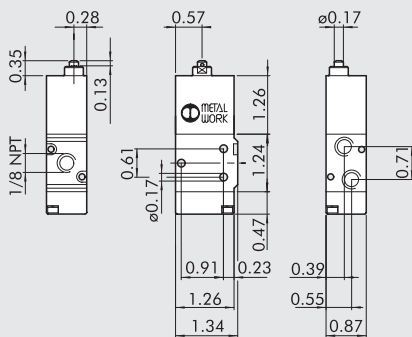

Symbol	Code	Abbrev.	Weight [lb]
	7010001800U	MAV 23 BRE NC U	0.273

PILOT-ASSISTED PLUNGER 5/2 1/8" NPT FOR PANEL ACTUATORS

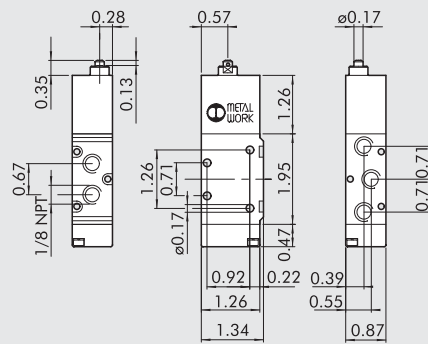

Symbol	Code	Abbrev.	Weight [lb]
	7010001900U	MAV 25 BRE OO U	0.331

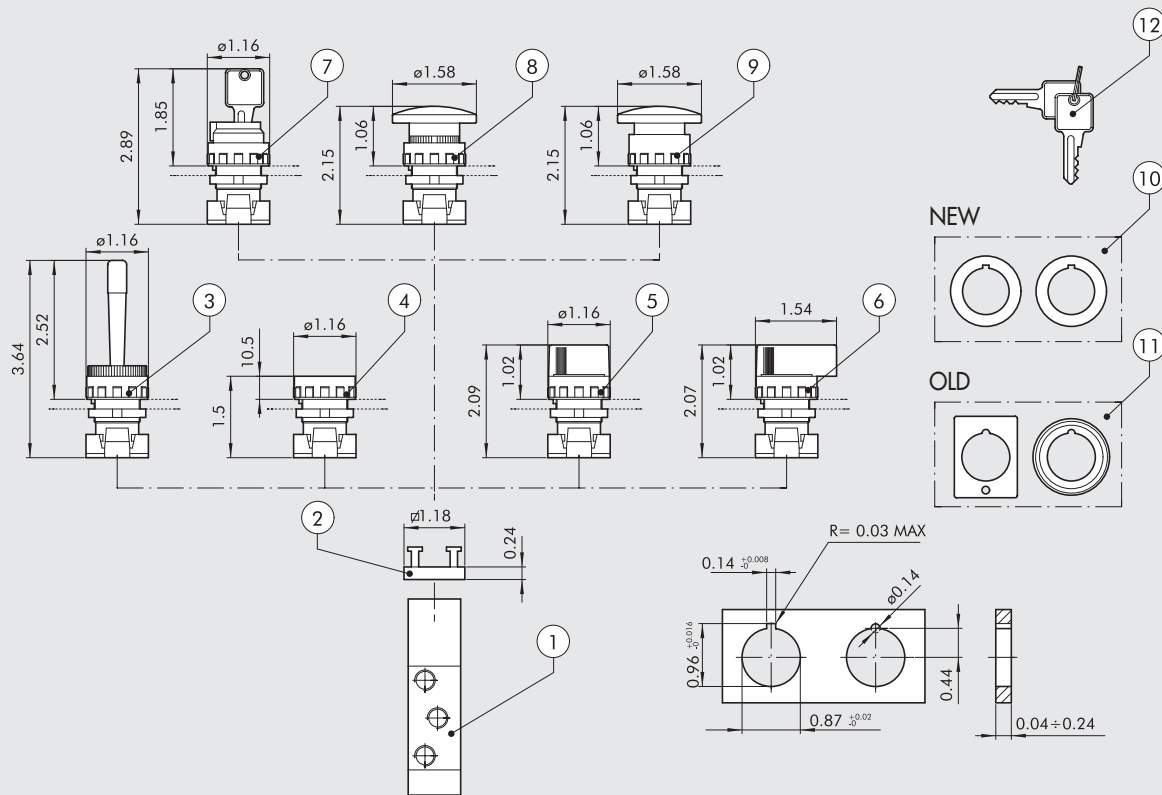
ASSEMBLY DIAGRAM FOR PILOT-ASSISTED HAND-OPERATED VALVES SERIES 70 WITH PANEL ACTUATORS

ORDERING CODES

Symbol	Reference	Code	Abbrev.	Description	Weight [lb]
	①	7010001800U	MAV 23 BRE NC U	Pilot-assisted plunger 3/2, 1/8" NPT	0.273
	①	7010001900U	MAV 25 BRE OO U	Pilot-assisted plunger 5/2, 1/8" NPT	0.331
	②	0351000050		2 places adaptor thickness 6.8 mm	0.015
	③	W0351000015		Red handler with horizontally pivoted lever	0.055
	④	W0351000011		Fat push button + 2 red/black coloured disks ◆ Bistable fat push button without disk	0.033
	⑤	W0351000030		Black selector short lever at 2 positions with return	0.044
		W0351000031		Black selector short lever at 2 positions	0.044
	⑤	W0351000032		Black selector short lever at 3 positions with return	0.044
		W0351000033		Black selector short lever at 3 positions	0.044
	⑥	W0351000034		Black selector long lever at 2 positions with return	0.057
		W0351000035		Black selector long lever at 2 positions	0.057
	⑥	W0351000036		Black selector long lever at 3 positions with return	0.057
		W0351000037		Black selector long lever at 3 positions	0.057
	⑦	W0351000016		2 positions key selector with extractable key in 2 positions	0.110
		W0351000018		2 positions key selector with extractable key in 0	0.110
	⑧	W0351000013		Red mushroom-head push button Ø 40 mm	0.060
		W0351000017		Black mushroom-head push button Ø 40 mm	0.060
	⑨	W0351000014		Red mushroom-head push button with lock Ø 40 mm	0.064
◆ It can't be supplied. As working replaced by selector with bistable short lever at 2 positions ⑤.	⑩	W0351000049		✚ Reducer from 30 to 22.5 mm	
✚ Usable only with technopolymer body selectors.	⑪	W0351000050		▲ Adapter for bore Ø 30 mm G2326	
▲ Usable only with metal body selectors.	⑫	W0351000021		✚ Key for ESC selectors	
		W0351000056		Green disk for push button ④	

VALVES SERIES 70, HAND-OPERATED, 1/4" NPT

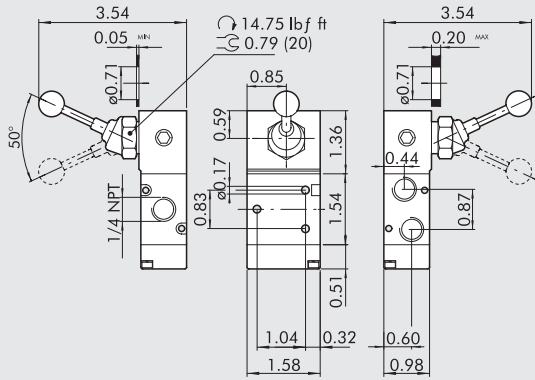
90° LEVER 3/2, 1/4" NPT



Symbol	Code	Abbrev.	Weight [lb]
	7020000100U	MAV 33 LES NC U	0.538
	7020000200U	MAV 33 LEB OO U	0.538

90° LEVER 5/2, 1/4" NPT

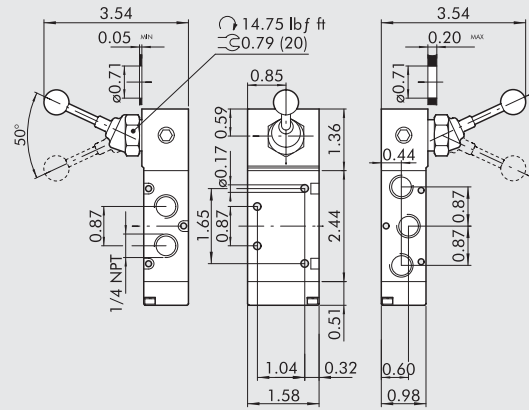

Symbol	Code	Abbrev.	Weight [lb]
	7020000300U	MAV 35 LES OO U	0.640
	7020000400U	MAV 35 LEB OO U	0.640

FRONT LEVER 3/2, 1/4" NPT

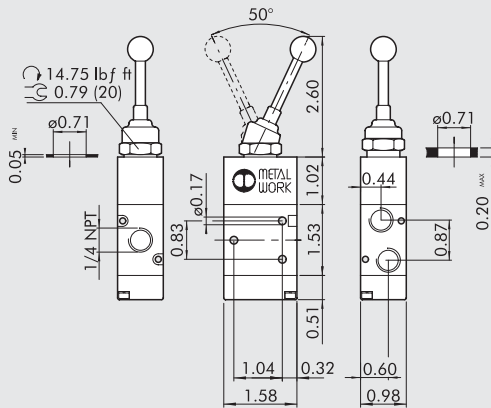

Symbol	Code	Abbrev.	Weight [lb]
	7020001400U	MAV 33 VLB OO U	0.428

FRONT LEVER 5/2, 1/4" NPT

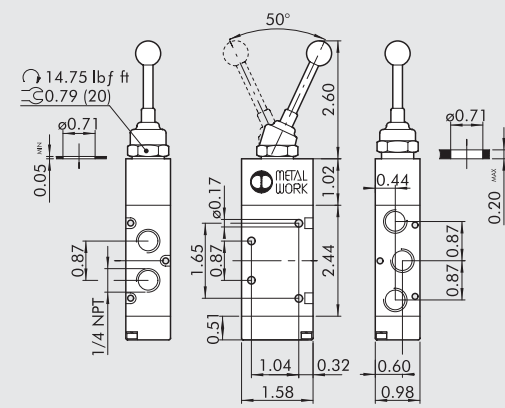

Symbol	Code	Abbrev.	Weight [lb]
	7020001700U	MAV 35 VLB OO U	0.538

90° LEVER 5/3, 1/4" NPT

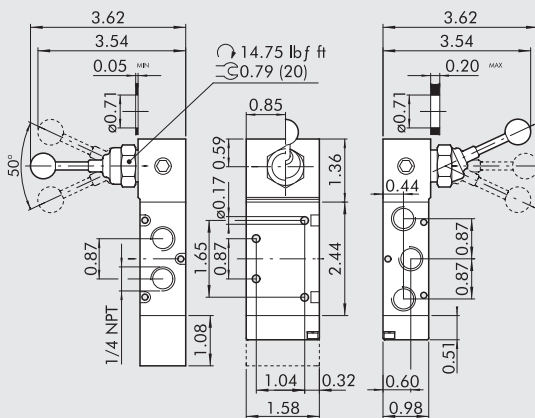

Symbol	Code	Abbrev.	Weight [lb]
	7020001000U	MAV 36 LES CC U	0.781
	7020000900U	MAV 36 LES OC U	0.781
	7020001100U	MAV 36 LES PC U	0.781
	7020000500U	MAV 36 LEO CC U	0.635
	7020000600U	MAV 36 LEO OC U	0.635
	7020000700U	MAV 36 LEO PC U	0.635

VALVES SERIES 70, HAND OPERATED, 1/2" NPT

90° LEVER 3/2, 1/2" NPT

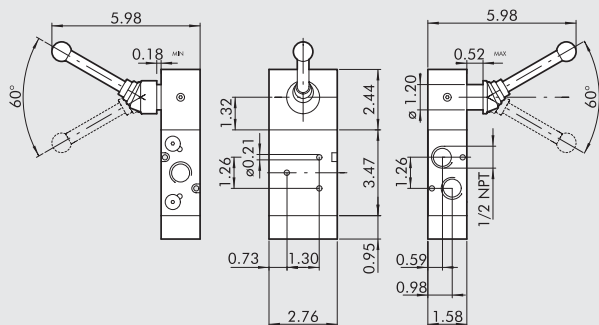

90° LEVER 5/2, 1/2" NPT

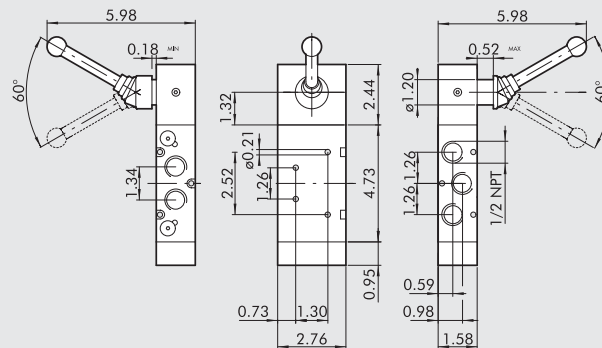

Symbol	Code	Abbrev.	Weight [lb]
	7030000100U	MAV 43 LES NC U	3.182
	7030000200U	MAV 43 LEB OO U	3.164

Symbol	Code	Abbrev.	Weight [lb]
	7030000300U	MAV 45 LES OO U	3.502
	7030000400U	MAV 45 LEB OO U	3.594

90° LEVER 5/3, 1/2" NPT

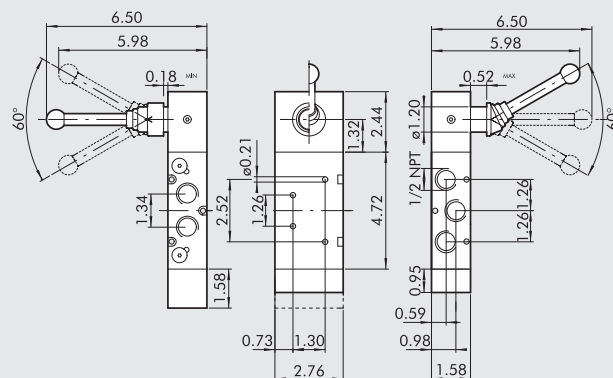

Symbol	Code	Abbrev.	Weight [lb]
	7030001000U	MAV 46 LES CC U	3.991
	7030000900U	MAV 46 LES OC U	3.969
	7030001100U	MAV 46 LES PC U	3.969
	7030000500U	MAV 46 LEO CC U	3.561
	7030000600U	MAV 46 LEO OC U	3.539
	7030000700U	MAV 46 LEO PC U	3.539

NOTES