

XLR-48 Supercapacitor

48 V, 166 F Rugged Module



Features

- Ultra low ESR provides high efficiency, high power
- Industry standard form factor for easy integration
- High power density to optimize system size and low operating costs
- Millions of charge/discharge cycles for life of application
- No heavy metals, RoHS compliant, non-hazardous energy storage
- Heavy duty metal housing for high vibration, high current applications
- IP65 environmental rating for high dust areas and water jet washable
- UL recognized

Applications

- Hybrid and electric vehicles
- Grid storage
- Commercial vehicles: trucks, mining, construction
- Automated guided vehicle (AGV)
- Trolley, subway
- Marine

Description

Eaton supercapacitors are high reliability, high power, ultra-high capacitance energy storage devices utilizing electrochemical double layer capacitor (EDLC) construction combined with proprietary materials and processes. This combination of advanced technologies allows Eaton to offer a wide variety of capacitor solutions tailored to applications for back up power, pulse power and hybrid power systems. They can be applied as the sole energy storage or in combination with batteries to optimize cost, life time and run time. System requirements can range from a few micro-amps to megawatts. All products feature low ESR for high power density with environmentally friendly materials for a green power solution. Eaton supercapacitors are maintenance-free with design lifetimes up to 20 years.



Powering Business Worldwide

Ratings

Capacitance	166 F
Maximum working voltage	48.6 V
Surge voltage	51.3 V
Capacitance tolerance	-0% to 20% (+20 °C)
Operating temperature range	-40 °C to +65 °C
Extended temperature range	-40 °C to +85 °C (with linear derating to 41.0 V @ +85 °C)

Specifications

Capacitance ¹ (F)	Part Number	Maximum initial ESR ¹ (mΩ)	Nominal leakage current ² (mA)	Stored energy ³ (Wh)	Peak power ⁴ (kW)	Pulse current ⁵ (A)	Continuous Current ⁶ (A)	Typical Thermal Resistance ⁷ Rth (°C/W)	Short Circuit Current ⁸ (A)
166	XLR-48R6167-R	5	5.2	54	118	2200	86	0.4	9700

Performance

Parameter (F)	Capacitance change (% of initial value)	ESR (% of maximum initial value)
Life (1500 hours @ +65 °C, 48.6 Vdc)	≤ 20%	≤ 200%
Storage (3 years, uncharged, <+35 °C)	≤ 5%	≤ 10%
Cycle Life ⁹ (1,000,000 cycles)	≤ 20%	≤ 200%

1. Capacitance and Equivalent Series Resistance (ESR) measured according to IEC62391-1 at +20 °C, with current in milliamps (mA) = 8°C*V

2. Leakage current at +20 °C after 72 hour charge and hold

3. Energy (Wh) = $\frac{1/2 * C * V^2}{3600}$

4. Peak Power (W) = $\frac{V^2}{4 * ESR}$

5. Pulse Current in Amps (A), 1 second discharge from rated voltage to half rated voltage = $\frac{1/2 * C * V}{(1 + ESR * C)}$

6. Continuous current with a 15 °C temperature rise. Continuous current (A) = $\sqrt{\frac{\Delta T}{ESR * Rth}}$

7. Thermal resistance (Rth) cell body temperature to ambient in open air in degrees C per Watt (°C/W)

8. Short circuit current is for safety information only. Do not use as operating current.

9. Cycling between rated voltage and half voltage, 3 seconds rest at +25 °C

Safety and certifications

Shock and vibration	IEC 61373 Cat. 1, Class B, SAE J2380, IEC16750-3 Table 14, SAE J2464
Warnings	Do not overvoltage, do not reverse polarity.
Environmental	IP65, RoHS
Shipping	UN3499, <10 Wh, Non-hazardous when shipped with shorting wire.

Dimensions (mm) and Mass (kg)

Part Number	W (max)	L (max)	H (max)	Typical Mass (kg)
XLR-48R6167-R	177	421	196	14.7

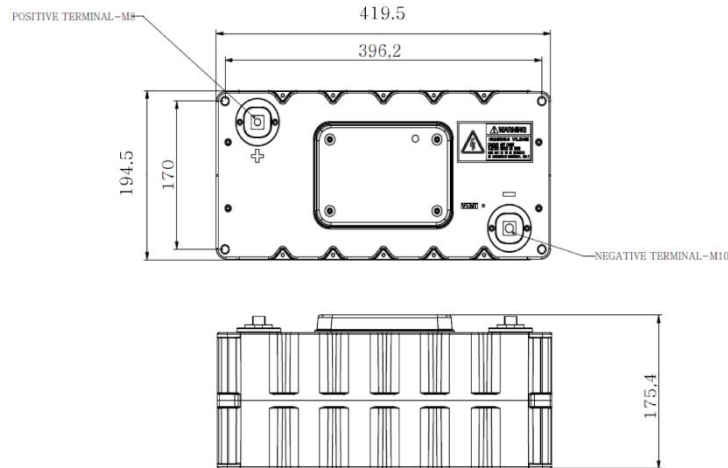

Part numbering system

XLR	-48R6	167	-R
Family Code	Voltage (V) R = decimal	Capacitance (μF) Value	Multiplier
XLR = Family code	48R6 = 48.6 V	Example 166 = 16.6 x 10 ⁷ (μF) or 166 F	RoHS compliant

Packaging information

- Standard packaging: 1 piece per box

Part marking

- Manufacturer
- Capacitance (F)
- Max operating voltage (V)
- Part number
- Polarity
- Serial number

Life Support Policy: Eaton does not authorize the use of any of its products for use in life support devices or systems without the express written approval of an officer of the Company. Life support systems are devices which support or sustain life, and whose failure to perform, when properly used in accordance with instructions for use provided in the labeling, can be reasonably expected to result in significant injury to the user.

Eaton reserves the right, without notice, to change design or construction of any products and to discontinue or limit distribution of any products. Eaton also reserves the right to change or update, without notice, any technical information contained in this bulletin.

Eaton
Electronics Division
1000 Eaton Boulevard
Cleveland, OH 44122
United States
www.eaton.com/electronics

© 2019 Eaton
All Rights Reserved
Printed in USA
Publication No. 10510 BU-MC
February 2019

Eaton is a registered trademark.

All other trademarks are property of their respective owners.

Follow us on social media to get the latest product and support information.

