

Model: ELPD-CAT6

Basic circuit diagram:

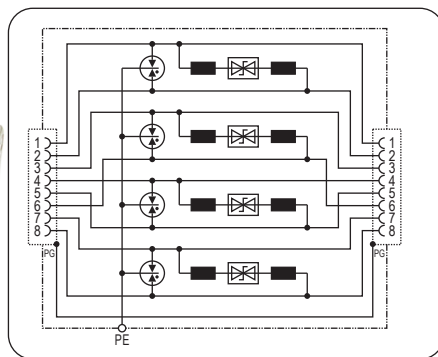

• Technical data

Type		ELPD-CAT6
Nominal voltage	U_N	48V-
Rated voltage (max. continuous voltage)	U_C	48V- / 34V~
Max. continuous voltage (PoE)	U_C	57V-
Nominal current	I_N	1A
Nominal discharge current (8/20)	I_n	0.15kA (line-line) 2.5kA (line-PG)
Total nominal discharge current (8/20)	I_n	10KA
Nominal discharge current (8/20) (PoE)	I_n	0.15kA (pair-pair)
Voltage protection level at I_n	U_p	$\leq 190V$ (line-line) $\leq 600V$ (line-PG)
Voltage protection level at I_n (PoE)	U_p	$\leq 600V$ (line-line)
Transmission frequency	f_G	500MHz
Insertion loss at 250MHz	a_E	$\leq 2dB$
Capacitance	C	$\leq 165pF$ (line-line) $\leq 255pF$ (line-PG)
Operating temperature range		-40°C...+80°C
Connection		RJ45 shield (input / output)
Shield earthing		Screw terminal
Mounting on		35mm DIN rail
Enclosure material		Aluminum
Test standards		IEC 61643-21; GB 18802.21; YD/T 1542
Certification		CE (LVD,EMC)

• Product introduction

1. Summary

ELPD-CAT6 is for installation at LZP 0_B-2 and higher interface or directly installed near the equipment; according to IEC standard for class 6 or class E integrated wiring system; all the industrial Ethernet 10M, 100M, 1Gbit network surge protection.

2. Main character

- For protecting computer data transmission system, network system and so on
- Good discharge capacity, low voltage protection level
- Quick response, high transmission speed, low signal attenuation
- RJ45 connection, easy for installation

3. Application

ELPD-CAT6 is applications in offices and industry like Gigabit Ethernet, ATM or ISDN system, and like VoIP or PoE system can be protected. (e.g. Switch, router, HUB, modem and so on)

4. Application environment

- Temperature: -40°C ~ +80°C
- Relative humidity: $\leq 95\%$ (25°C)

• Installation instruction

1. This product is connected in series to the protected device.
2. Mount the SPD on 35 mm DIN rail.
3. The OUT terminal should be connected to the protected devices.
4. SPD's earthing terminal must be connected to nearby earthing BusBar or the metal earthing enclosure of protected device.
5. After above, you should ensure the circuit is functioning.

Regularly inspect the operating status, especially after lightning.
Once the communication is off, electrician should check/replace the SPD.

Installation diagram

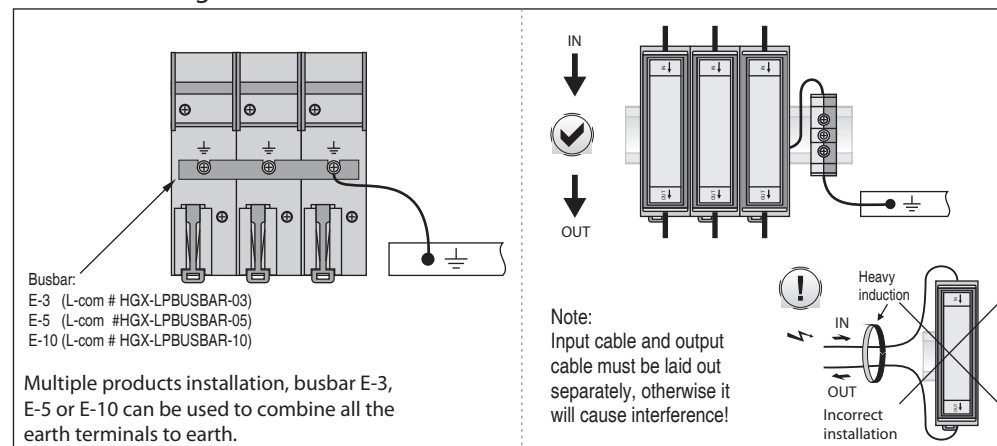

WARNING:

1. The device must be installed by electrically skilled person, conforming to national standards and safety regulations.
2. It is recommended that installation should be done under power off condition.