











## Sensor, Series SN2

- Plug, M8, 2-pin, Plug, M8, 3-pin, Plug, M8, 4-pin
- Reed 2-Wire, Reed 3-Wire, Reed 3-Wire, with pulse stretching, Reed 4-Wire, electronic PNP
- With stretched impulse
- With stretched impulse
- Reed, electronic PNP
- Indirect mounting for series TRB, PRA, ITS, MNI, CSL-RD, ICM, RPC, TRR, FLT, CVI



Ambient temperature min./max.	See table below
Protection class	IP67
Switching point precision	±0,1 mT
Nominal current, actuated state	15 mA
Quiescent current (without load)	10 mA
Min./max. DC operating voltage	See table below
Min./max. AC operating voltage	See table below
LED status display	See table below

## Technical data

Part No.		Type of contact	Min./max. DC operating voltage
0830100465		Reed	12 ... 36 V DC
0830100468		Reed	12 ... 36 V DC
R412004299		Reed	12 ... 36 V DC
0830100466		Reed	12 ... 36 V DC
0830100469		Reed	12 ... 36 V DC
R412004820		Reed	12 ... 36 V DC
0830100472		Reed	12 ... 36 V DC
0830100467		Reed	12 ... 36 V DC
0830100480		electronic PNP	10 ... 30 V DC
R412004800		electronic PNP	10 ... 30 V DC

Part No.	Min./max. AC operating voltage	Voltage drop U at I <sub>max</sub>
0830100465	12 ... 30 V AC	2,1 V + I*Rs
0830100468	12 ... 30 V AC	2,1 V + I*Rs
R412004299	12 ... 30 V AC	2,1 V + I*Rs
0830100466	12 ... 30 V AC	2,1 V + I*Rs
0830100469	12 ... 30 V AC	≤ 0,5 V
R412004820	12 ... 30 V AC	I*Rs
0830100472	12 ... 30 V AC	≤ 1,5 V
0830100467	12 ... 30 V AC	≤ 3,5 V
0830100480	12 ... 30 V AC	≤ 2,0 V
R412004800	-	≤ 2,0 V

Part No.	DC switching current, max.	AC switching current, max.
0830100465	0.13 A	0.13 A
0830100468	0.3 A	0.5 A
R412004299	0.13 A	0.13 A
0830100466	0.13 A	0.13 A
0830100469	0.13 A	0.13 A
R412004820	0.13 A	0.13 A
0830100472	0.2 A	0.13 A
0830100467	0.13 A	0.13 A
0830100480	0.13 A	-
R412004800	0.13 A	-

Part No.	Function	Ambient temperature min./max.
0830100465	Reed 2-Wire	-4 ... 176 °F
0830100468	Reed 2-Wire	-4 ... 176 °F
R412004299	Reed 3-Wire	-4 ... 176 °F
0830100466	Reed 3-Wire	-4 ... 176 °F
0830100469	Reed 3-Wire	-4 ... 176 °F

Part No.	Function	Ambient temperature min./max.
R412004820	Reed 3-Wire	-4 ... 176 °F
0830100472	Reed 3-Wire, with pulse stretching	-4 ... 158 °F
0830100467	Reed 4-Wire	-4 ... 176 °F
0830100480	electronic PNP	14 ... 158 °F
R412004800	electronic PNP	14 ... 158 °F

Part No.	Switching capacity	Protective resistor for reed	Vibration resistance
0830100465	10 W / 10 VA	27 Ω	30 g (50 - 2000 Hz)
0830100468	10 W / 10 VA	1,3 Ω	30 g (50 - 2000 Hz)
R412004299	10 W / 10 VA	27 Ω	30 g (50 - 2000 Hz)
0830100466	10 W / 10 VA	100 Ω	30 g (50 - 2000 Hz)
0830100469	5,5 W / 5,5 VA	27 Ω	30 g (50 - 1000 Hz)
R412004820	10 W / 10 VA	27 Ω	30 g (50 - 2000 Hz)
0830100472	5 W / 5 VA	-	35 g (50 - 2000 Hz)
0830100467	10 W / 10 VA	27 Ω	35 g (50 - 2000 Hz)
0830100480	-	-	-
R412004800	-	-	-

- 1) Plug M8, 2-pin
- 2) Plug M8, 3-pin
- 3) Plug M8, 4-pin

## Technical information

If reed sensors are used, we recommend using a short-circuit protective device (SCPD).

## Technical information

### Material

Housing	Polyamide, epoxy resin
---------	------------------------

Dimensions

Fig. 1

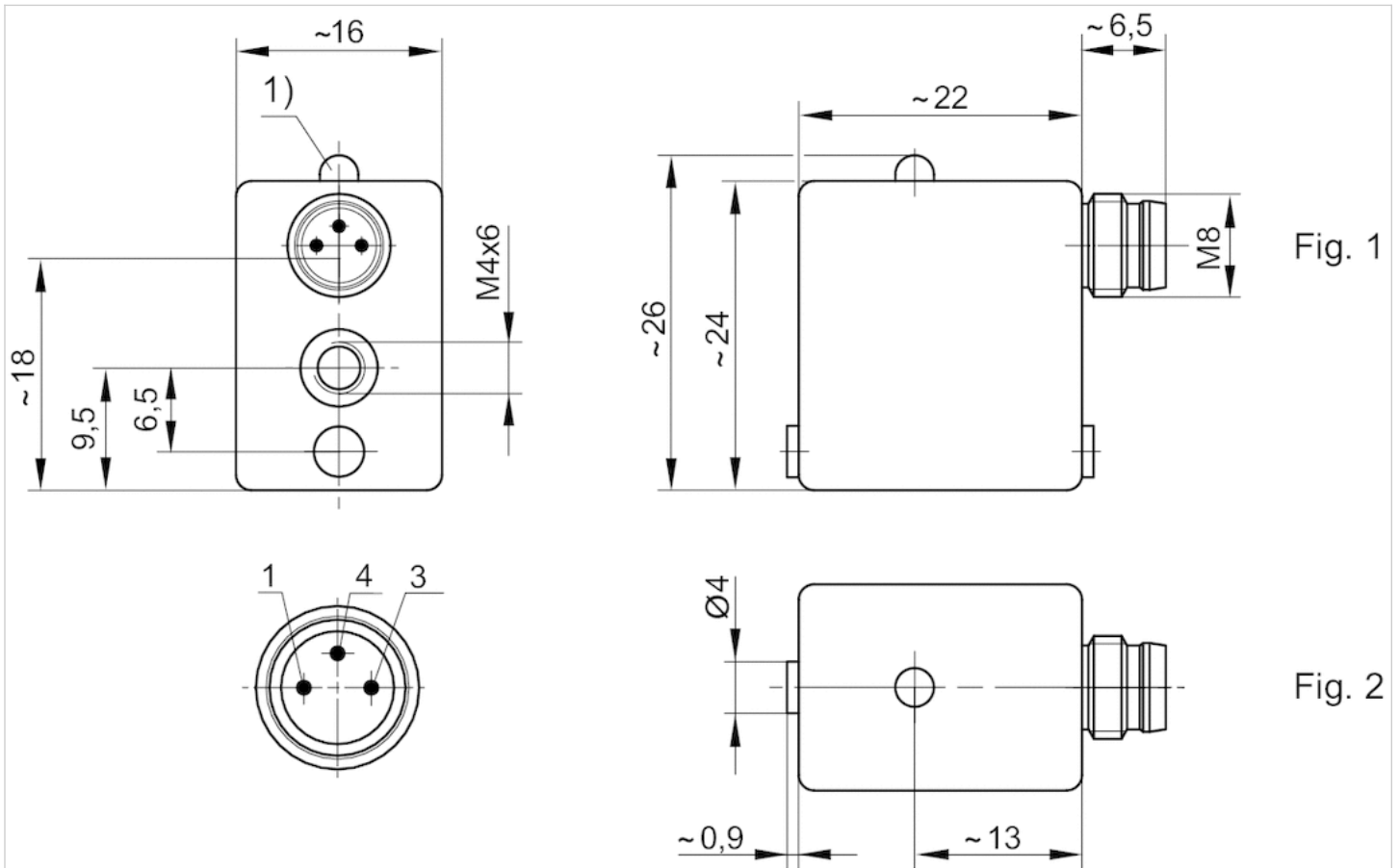

1) LED

M8: combination plug can be combined with valve plug connectors Ø6.5 mm and M8.

Pin assignments: 1 = (+), 3 = (-), 4 = (OUT), EN 60947-5-2:1998

Fig. 2

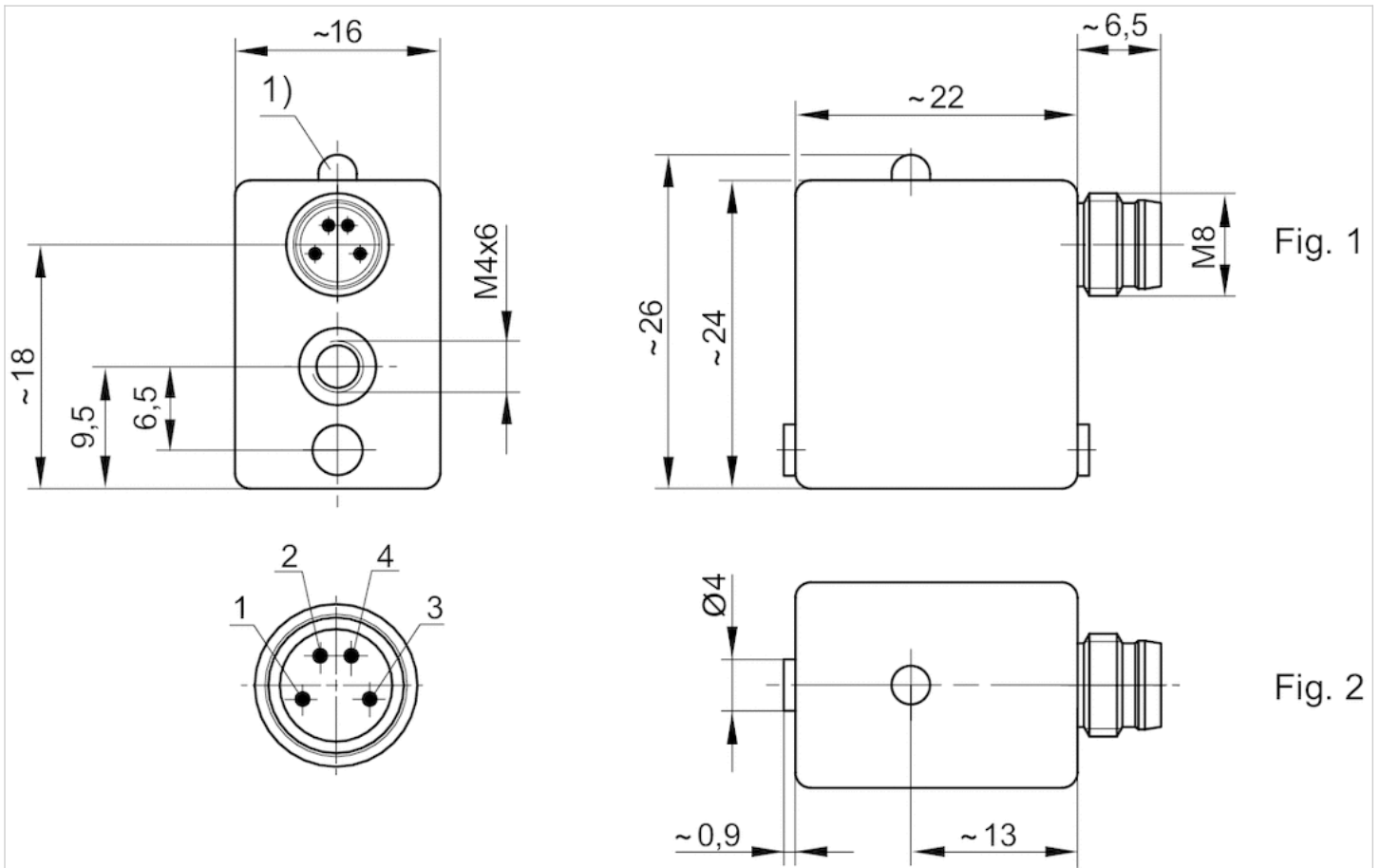

1) LED

M8: combination plug can be combined with valve plug connectors Ø6.5 mm and M8.

Pin assignments: 1 = (+), 3 = (-), 4 = (OUT), EN 60947-5-2:1998