

Country	Jurisdiction & Control List
FR	NOT LISTED

	critical dimension
	major dimension

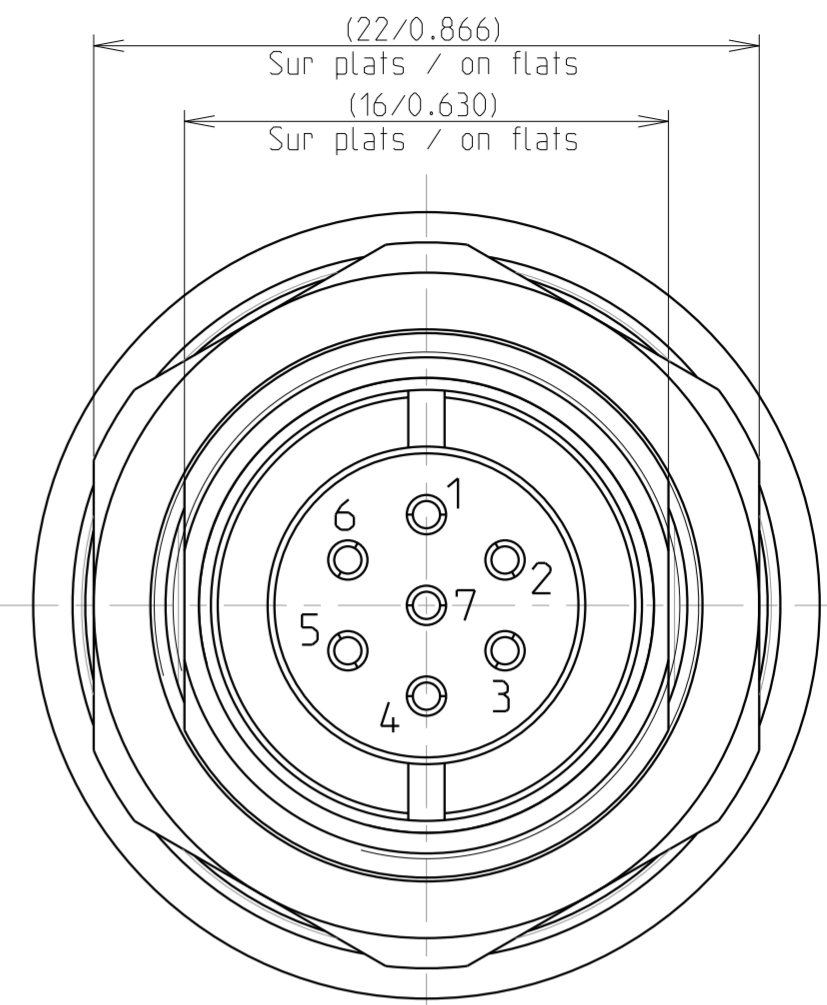
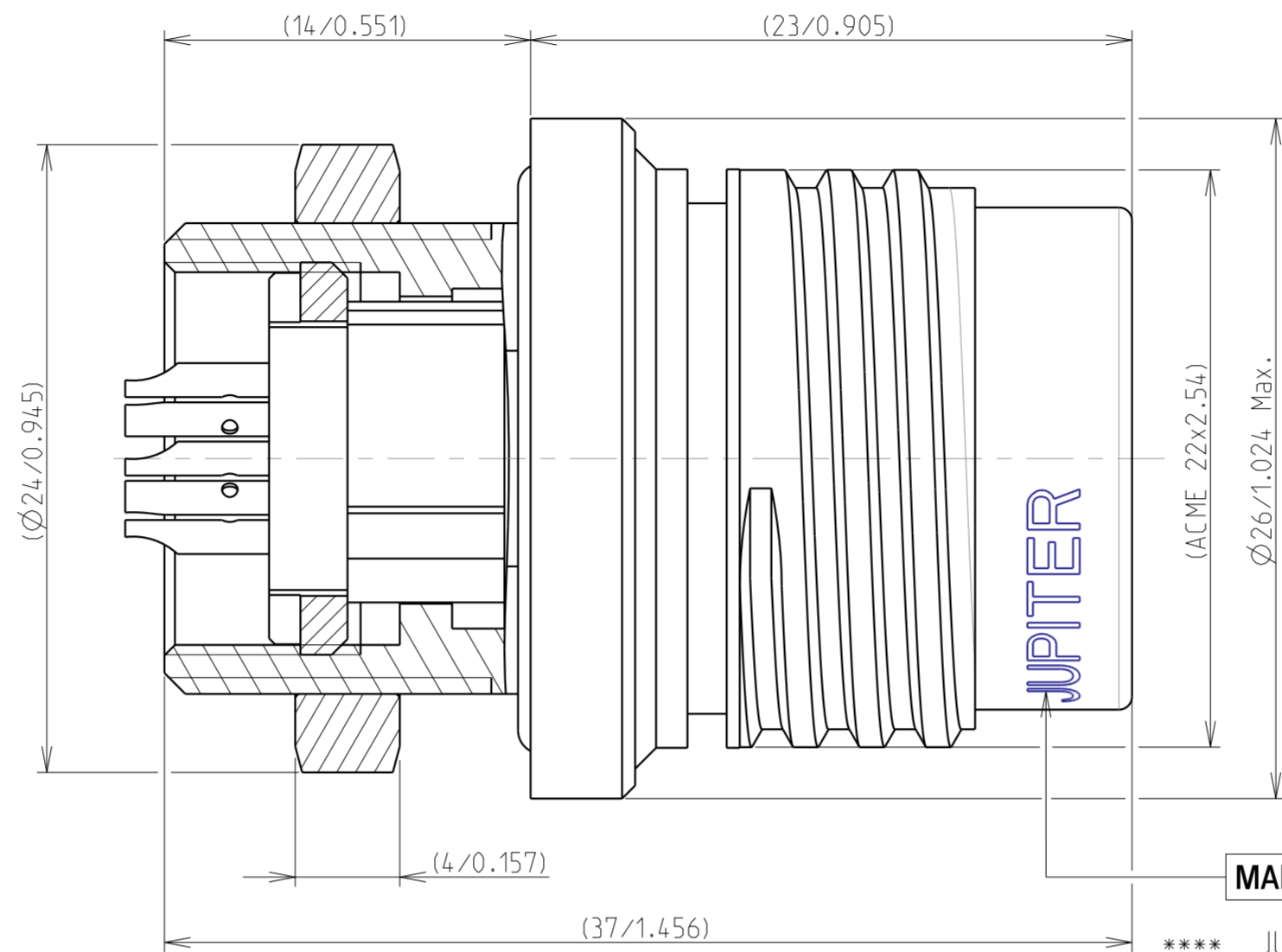
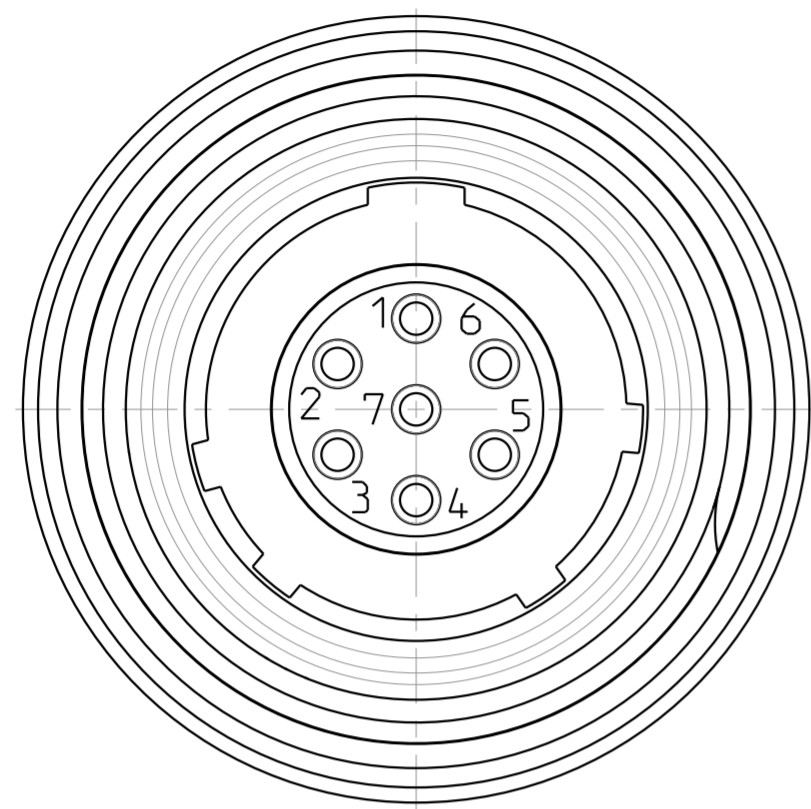

MARQUAGE/MARKING

**** JUPITER FR RER10PL
 — SEMAINE/WEEK
 — ANNEE/YEAR

**REFERENCE COMMERCIALE
 PART NUMBER**

RER10PLN0720Y

TYPE DE CONTACT/CONTACT TYPE
 M:MALE/PIN F:FEMELLE/SOCKET
 MATIERE DE L'ISOLANT/INSERT MATERIAL
 N:PA6/6+MOS2(NYLATRON) T:PTFE(TEFLON)
 ARRANGEMENT DES CONTACTS/CONTACT LAYOUTS
 VOIR STI-PL54-0001/SEE STI-PL54-0001

N1 : SERRAGE SUR PANNEAU COUPLE 3.5 N.m
 TIGHTENING ON PANEL TORQUE 3.5 N.m

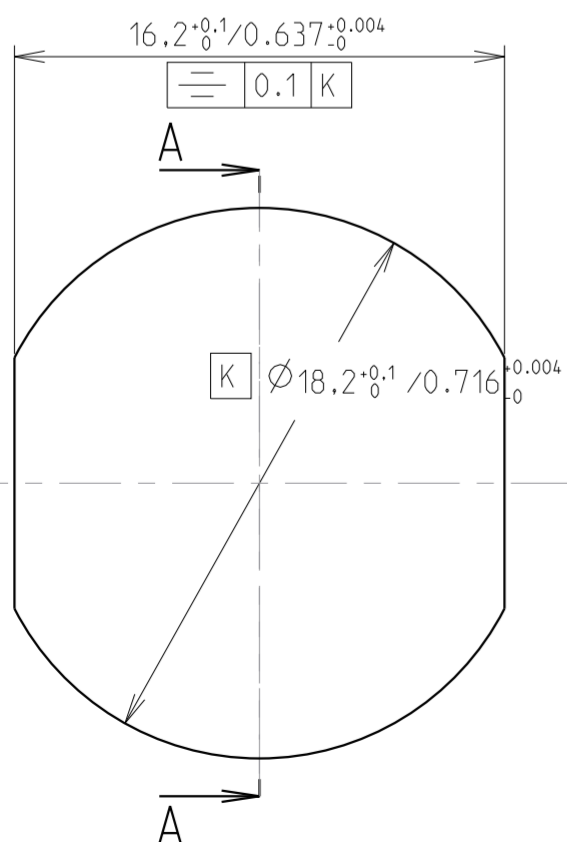

**DECOUPE DU PANNEAU
 PANEL CUT OUT**

SCALE 4/1

CUT A-A

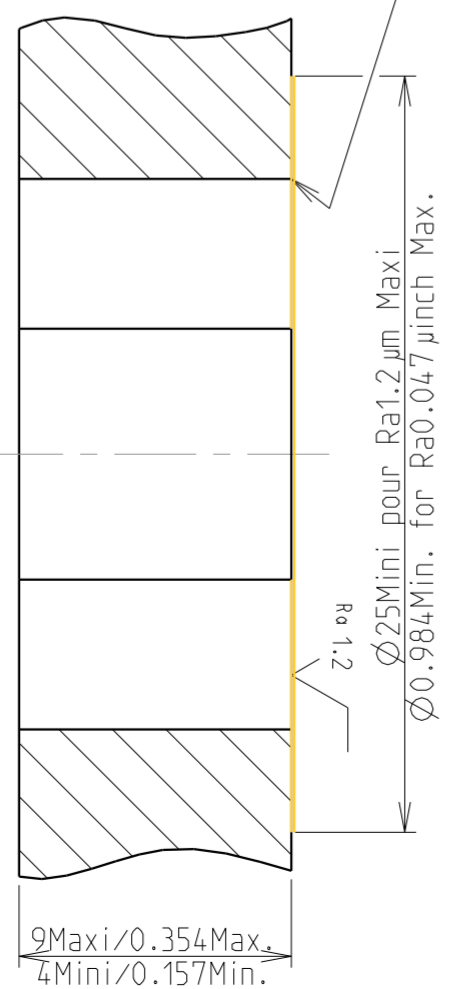

Cassage d'angle 0.2 Maxi
 Edge breaking 0.008in Max.

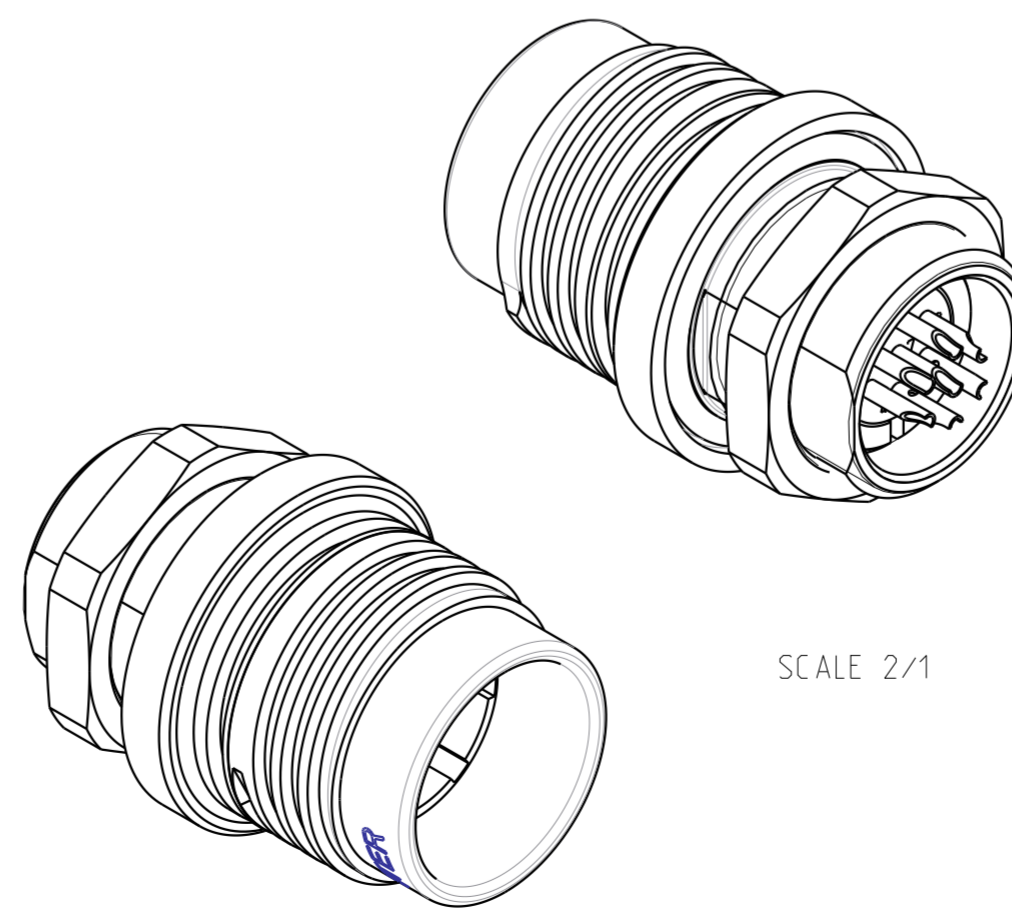

SCALE 2/1

A	11/07/16	Initial drawing	ORAIN	MEFFRE	DIFF
Iss	Date	MODIFICATIONS	A C Naf.	Designed by	Checked by
MATERIAL --		TREATMENT	PROTECTION/PLATING		
--		--	--		
--		--	CODE --		
DIMENSIONS ARE DEFINED BEFORE PLATING					
TITLE		EMBASE RER / RECEPTACLE RER			PROJECT
		SERIE PL - TAILLE 10 (CONTACTS A SOUDER / SOLDER CONTACTS)			PL54
Material Reference Voir Référence Commerciale / See Part Number					
		Generales tolerances ISO 2768		SOURIAU	
Scale 4/1		General machining Surface texture		SOURIAU 3. RUE DU VALLON ZAC N°2 94440 MAROLLES-EN-BRIE (FRANCE) TEL. 33 (0)1 45 10 78 00	
Geometrical Tolerances: NF EN ISO 1101		This document is the property of SOURIAU it must not be reproduced or communicated without permission.		FORMAT A2	SOURIAU DRG N° 542E0030A9C
				Iss A	SHEET 1/1