



ENGLISH

Datasheet

RS Pro Article: 1449415

## RS Pro 18650 26H Li-ion Battery Pack Tested and approved to UN38.3



### 1 Preface

This manual describes the type and size, performance, technical characteristics, warning and caution.

### 2 Product and Model

2.1 Products: Lithium-ion Battery Pack

2.2 Model: RS Pro ICR 18650-26H M(18650 2600 Ah 14.8 V 4S1P B4)

2.3 Picture and output wire (To prevail in kind)

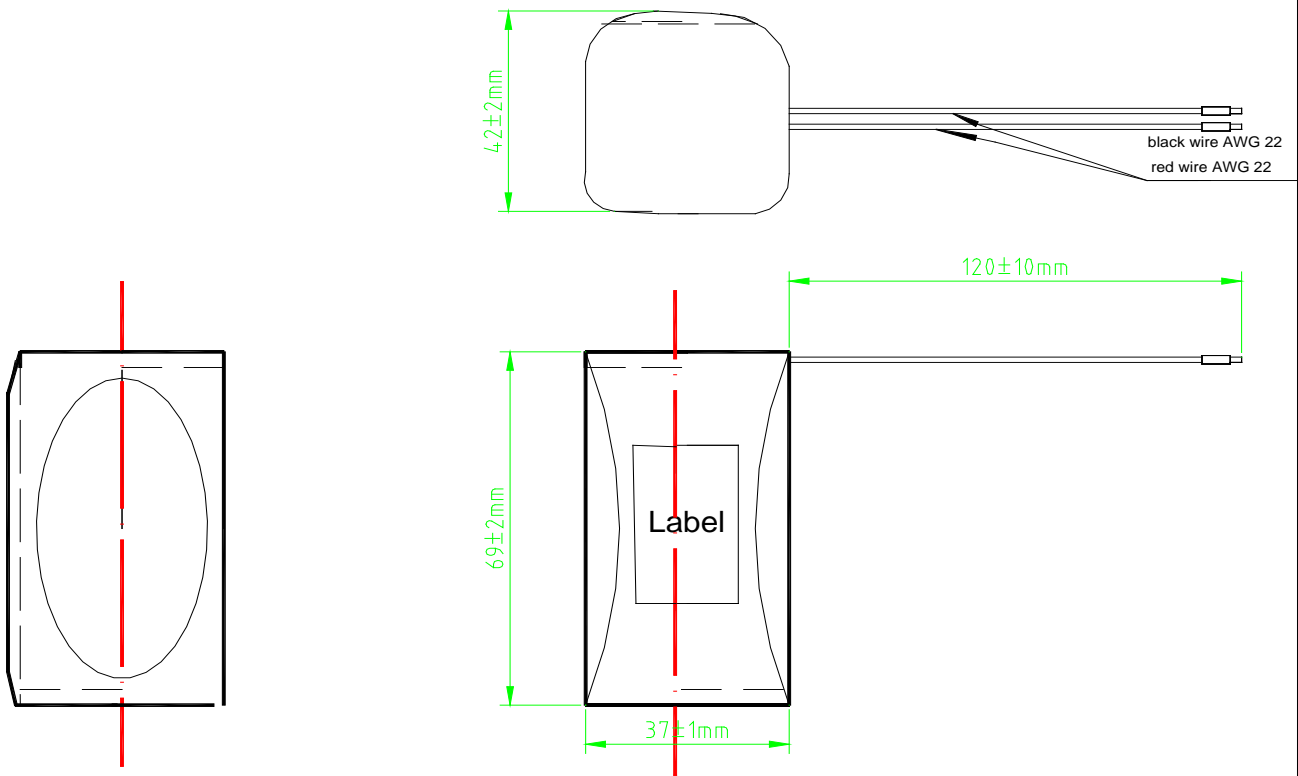

1.	Positive	Red one wire with 22 AWG	Length: $120 \pm 10 \text{ mm}$	Molex 39-01-4021
2.	Negative	Black one wire with 22 AWG	Length: $120 \pm 10 \text{ mm}$	

### 3 Battery Pack Specifications

Item		Parameters
Nominal Voltage		14.8 V
Typical capacity		2. 6Ah (At 0.2°C, 8.25 V discharge)
Discharge	Max. Discharge Current	> 4 A (ambient temperature 25°C)
	Cut-off voltage	11 V
Charge	Voltage	12.60 ±0.05 V
	Current	Standard Charge: 0.5°C Rapid Charge: 1°C
	Max. Current	1°C (ambient temperature 25°C)
	Charge mode	CC/CV, use special lithium charger
Inner resistance	Discharging Inner resistance	≤ 100 mΩ
Operation temperature / humidity range	Charge	0°C to +52°C
	Discharge	-20°C to +60°C
		When the environment temperature is higher than 45°C, pay attention to ventilation and heat rejection.
Storage temperature/ humidity range	Temperature	1 year: -20 to 20°C 3 months: -20 to 45°C 1 month: -20 to 60°C
Protection function		Over charge protection, Over discharge protection
Shell material		PVC
Weight		188 g
Size (L x W x H) mm		37x 69 x 42 ± (1-2-1 mm)

#### 4. Protective circuits (CL-S04-019-A01-F4ST)

Item	Min.	Typical.	Max.	Unit.
Over-Charge detect voltage	4.225	4.25	4.275	V
Over-Charge recovery voltage	4.10	4.15	4.20	V
Over-Discharge detect voltage	2.62	2.70	2.78	V
Over-Discharge recovery voltage	2.90	3.00	3.10	V
Overcurrent protection	9	13	17	A
Idle mode			50	$\mu$ A
Operating Temperature	-20	25	60	$^{\circ}$ C
Main loops electrify resistance			100	m $\Omega$

