

## Interface converters - GW EIP/MODBUS 1E/2DB9 - 1062423

Please be informed that the data shown in this PDF Document is generated from our Online Catalog. Please find the complete data in the user's documentation. Our General Terms of Use for Downloads are valid (<http://phoenixcontact.com/download>)



The GW EIP/MODBUS... enables two-way communication between EtherNet/IP™ and Modbus protocols. Includes one RJ45 port and two D-SUB 9 ports.



### Key Commercial Data

Packing unit	1 pc
GTIN	 4 055626 718460
GTIN	4055626718460

### Technical data

#### Note

Utilization restriction	EMC: class A product, see manufacturer's declaration in the download area
-------------------------	---

#### Dimensions

Width	22,5 mm
Height	99 mm
Depth	115 mm

#### Ambient conditions

Ambient temperature (operation)	-40 °C ... 70 °C
Ambient temperature (storage/transport)	-40 °C ... 80 °C
Permissible humidity (operation)	10 % ... 95 % (non-condensing)
Permissible humidity (storage/transport)	5 % ... 95 % (non-condensing)
Altitude	< 2000 m
Degree of protection	IP20
Noise immunity	EN 61000-6-2:2005

#### General

Electrical isolation	IEC UL 61010-1 (VCC // Ethernet)
----------------------	----------------------------------

# Interface converters - GW EIP/MODBUS 1E/2DB9 - 1062423

## Technical data

### General

Test voltage data interface/data interface	1.5 kV <sub>rms</sub> (50 Hz, 1 min.)
Test voltage data interface/power supply	1.5 kV <sub>rms</sub>
	1.5 kV <sub>rms</sub> (50 Hz, 1 min.)
Electromagnetic compatibility	Conformance with EMC Directive 2014/30/EU
Noise emission	EN 61000-6-4
Net weight	185 g
Housing material	PA 6.6
Color	gray
MTBF	69.4 Years (Telcordia standard, 25°C temperature, 50% stress, Environmental Factor = 1.0)
	46.3 Years (Telcordia standard, 40°C temperature, 50% stress, environmental factor = 1.0)
Conformance	CE-compliant
UL, USA	UL 61010-1
UL, USA/Canada	Class I, Div. 2, Groups A, B, C, D T4A

### Power supply

Supply voltage range	10.8 V DC ... 30 V DC (via pluggable COMBICON screw terminal block)
Max. current consumption	85 mA (24 V DC)
Typical current consumption	76 mA (24 V DC)
Conductor cross section flexible max.	2.50 mm <sup>2</sup>
Conductor cross section flexible min.	0.20 mm <sup>2</sup>
Conductor cross section AWG max.	12
Conductor cross section AWG min.	24

### Serial interface

Interface 1	EtherNet/IP™, MODBUS TCP
Interface	Ethernet
No. of ports	1
Connection method	RJ45 socket, shielded
Transmission length	≤ 100 m (shielded twisted pair)
Protocols supported	EtherNet/IP, MODBUS ASCII/RTU/TCP
Auxiliary protocols	ARP, DHCP (Client), PING
Serial transmission speed	10/100 Mbps, auto negotiation
Interface	RS-232
Number of connections	2
Connection method	D-SUB 9 plug
File format/coding	5/6/7/8 Data bits, 1/2 Stop bits, None/Even/Odd/Mark/Space Parity
Transmission length	15 m
Data flow control/protocols	Software handshake, Xon/Xoff or hardware handshake RTS/CTS
Serial transmission speed	0.3; 0.6; 1.2; 2.4; 4.8; 9.6; 19.2; 38.4; 57.6; 115.2; 230.4 Kbps
Interface	RS-422

# Interface converters - GW EIP/MODBUS 1E/2DB9 - 1062423

## Technical data

### Serial interface

Number of connections	2
Connection method	D-SUB 9 plug
File format/coding	5/6/7/8 Data bits, 1/2 Stop bits, None/Even/Odd/Mark/Space Parity
Transmission length	≤ 1200 m
Termination resistor	120 Ω (configurable)
Serial transmission speed	0.3; 0.6; 1.2; 2.4; 4.8; 9.6; 19.2; 38.4; 57.6; 115.2; 230.4 Kbps
Interface	RS-485
Number of connections	2
Connection method	D-SUB 9 plug
File format/coding	5/6/7/8 Data bits, 1/2 Stop bits, None/Even/Odd/Mark/Space Parity
Termination resistor	120 Ω (configurable)
Serial transmission speed	0.3; 0.6; 1.2; 2.4; 4.8; 9.6; 19.2; 38.4; 57.6; 115.2; 230.4 Kbps

### Function

Web-based management	yes
Management	Web-based management

### Standards and Regulations

Electromagnetic compatibility	Conformance with EMC Directive 2014/30/EU
Type of test	Vibration resistance in acc. with EN 60068-2-6/IEC 60068-2-6
	Shock in acc. with EN 60068-2-27/IEC 60068-2-27
Noise emission	EN 61000-6-4
Noise immunity	EN 61000-6-2:2005
Standards/regulations	EN 55022, EN 55024
Conformance	CE-compliant
UL, USA	UL 61010-1
UL, USA/Canada	Class I, Div. 2, Groups A, B, C, D T4A
Noxious gas test	ISA-S71.04-1985 G3 Harsh Group A
ATEX	DEMKO 18ATEX 2026X: II 3 G Ex ec IIC T4 Gc
IECEX	IECEX UL 18.0023X Ex ec IIC T4 Gc

### Environmental Product Compliance

REACH SVHC	Lead 7439-92-1
------------	----------------

## Drawings

# Interface converters - GW EIP/MODBUS 1E/2DB9 - 1062423

Block diagram

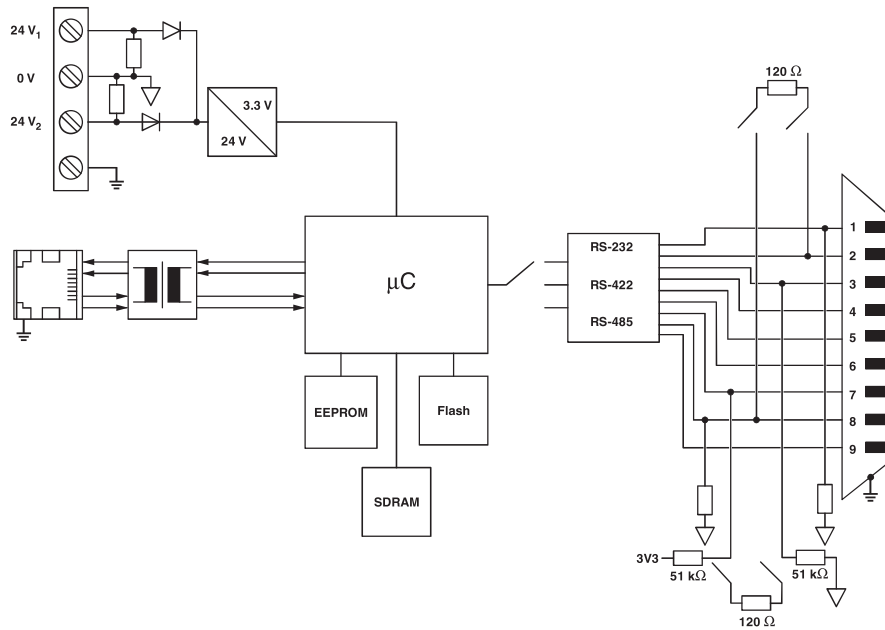

## Approvals

Approvals

Approvals

UL Listed / cUL Listed / cULus Listed

Ex Approvals

IECEX / ATEX / UL Listed / cUL Listed / cULus Listed

## Approval details

UL Listed		<a href="http://database.ul.com/cgi-bin/XYV/template/LISEXT/1FRAME/index.htm">http://database.ul.com/cgi-bin/XYV/template/LISEXT/1FRAME/index.htm</a>	FILE E 238705
cUL Listed		<a href="http://database.ul.com/cgi-bin/XYV/template/LISEXT/1FRAME/index.htm">http://database.ul.com/cgi-bin/XYV/template/LISEXT/1FRAME/index.htm</a>	FILE E 238705
cULus Listed			

---

Phoenix Contact 2019 © - all rights reserved  
<http://www.phoenixcontact.com>

PHOENIX CONTACT GmbH & Co. KG  
Flachsmarktstr. 8  
32825 Blomberg  
Germany  
Tel. +49 5235 300  
Fax +49 5235 3 41200  
<http://www.phoenixcontact.com>