

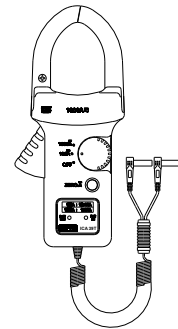

INSTRUCTION MANUAL
ICA39T AC/DC CURRENT TRANSDUCER

EN



INTRODUCTION



1-1 Unpacking and Inspection

Upon removing your new Clamp Meter from its packing, you should have the following items:

1. Current Transducer with coiled cable output plugs.
2. Carrying Case.
3. Instruction manual.

1-2 Meter Safety

Terms as Marked on Equipment

-  **ATTENTION** — Refer to manual
-  **DOUBLE INSULATION** — Protection Class II.
-  **DANGER** — Risk of electric shock.

Symbols in this Manual

 This symbol indicates where cautionary or other information is found in the manual.

 **Battery**

1-3 Front Panel

Refer to Figure 1 and the following numbered steps to familiarize yourself with the meter's front panel controls and Connectors.

1. **Red LED** — Low battery display.
2. **Green LED** — Power on display.
3. **Coiled Cable Output Leads** — Voltage output.
4. **Function Switch** — Function select switch used to select measuring function.
5. **DC Zero Button** — DCA AUTO ZERO on DC current ranges.
6. **Trigger** — Press the lever to open the transformer jaws.
7. **Transformer Jaws** — Designed to pick up the a.c./d.c. current following through the conductor.

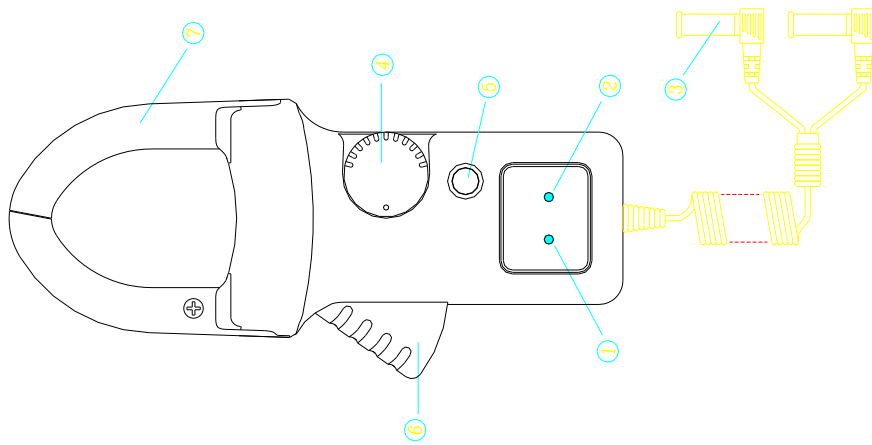

Figure 1

SPECIFICATIONS

2-1 General Specifications

Position Error	: +/- 1% of Reading.
Type Of Sensing	: Hall effect sensing for AC and DC.
Low Battery Indicator	: Red LED indicator.
Power On Indicator	: Green LED indicator , flashing.
Temperature Coefficient	: $0.2 \times (\text{Spec.Acc'y}) / ^\circ\text{C}$, $< 18^\circ\text{C}$ or $> 28^\circ\text{C}$.
Power Requirement	: Alkaline 9V battery .
Battery Life	: 66 hours typical (Alkaline).
Max / Conductor Size	: 51mm diameter or 24 x 60mm busbar.
Size	: 90mm (W) x 232mm (L) x 32mm (H).
Weight	: 420 grams
Accessories	: Coiled cable output plugs (installed) , manual and carrying case.

2-2 Environmental Conditions:

Indoor use.

Maximum Altitude : 2000 Meter

Installation Category : IEC 1010 1000V CAT. III.

Pollution Degree : 2

Operating Ambient : 0°C ~ 50°C , <75%R.H.

Storage Temperature : -20°C ~ 60°C, < 80% R.H.

2-3 Electrical Specifications

All at 23°C ± 5°C, less than 75% R.H.

Ranges : 0 ~ 100A/1000A AC
0 ~ 100A/1000A DC

Accuracy

(1) DC Current :

Ranges : 100A, 1000A

Output Voltage : 10mV / A for 100A Range

1mV / A for 1000A Range

Accuracy : 100A Range : (0 - 100)A ±(2.9% + 2A)

1000A Range : (100 - 400)A ± (1.9% + 7A)

1000A Range : (400 - 1000)A ± (2.9% + 5A)

(2) AC Current :

Ranges : 100A, 1000A

Output Voltage : 10mV / A for 100A Range
1mV / A for 1000A Range

Accuracy : 100A Range : (0 - 100)A $\pm(1.9\% + 2A)$ 40-400Hz

1000A Range : (100 - 400)A $\pm(1.9\% + 7A)$ 40-400Hz

1000A Range : (400 - 1000)A $\pm(2.9\% + 5A)$ 40-400Hz

Load Impedance : 100K Ω min.AC/DC

(3) Auto Power Off : Approximately 30 minutes after function changes.

OPERATION

This instrument has been designed and tested in accordance with IEC Publication 1010, Safety Requirements for Electronic Measuring Apparatus and has been supplied in a safe condition. This instruction manual contains some information and warnings which have to be followed by the user to ensure safe operation and to retain the instrument in safe condition.

3-1 Precautions and Preparations for measurement

1. Do not apply the voltage to the output plugs.
2. Make sure that the battery is connected properly.
3. Operate the instrument only in temperature between 0°C ~ 50°C and less than 75% R.H.
4. Do not use or store this instrument in high temperature or high humidity and do not store the unit in direct sunlight.
5. If the unit is not to be used for a long period of time, remove the battery.
6. Do not forget to turn power switch off after use.
7. If the meter is used near equipment that generates electro-magnetic, the output may be unstable or indicate incorrect measurement values.

**⚠ THIS INSTRUMENT MUST NOT BE USED ON UNINSULATED CONDUCTORS AT A VOLTAGE
GREATER THAN 1000V ac/dc.**

3-2 AC Current Measurement

1. Select the highest anticipated input (1000A or 100A) by the function switch.
2. Insert the "Output plugs (red and black)" to the input terminals of a Multimeter.

Set the Multimeter to "AC 200mV or 2V" range.

3-3 DC Current Measurement

1. Select the highest anticipated input (1000A or 100A) by the function switch.
2. Insert the "Output plugs (red and black) " to the input terminals of a Multimeter.
Set the Multimeter to "DC 200mV or 2V" range.
3. Be sure to zero adjust first. With jaws closed and away from conductor, continue to press DCA AUTO ZERO Button until instrument reads all zeroes or very close to it.
4. For DC measurement, output is positive in the red plug when the current flows from the lower side to the upper side of the transducer as shown in Figure 2.
5. Press the trigger to open the transformer jaws and clamp one conductor only, make sure that the jaw is firmly closed around the conductor, then read the display from the multimeter directly.

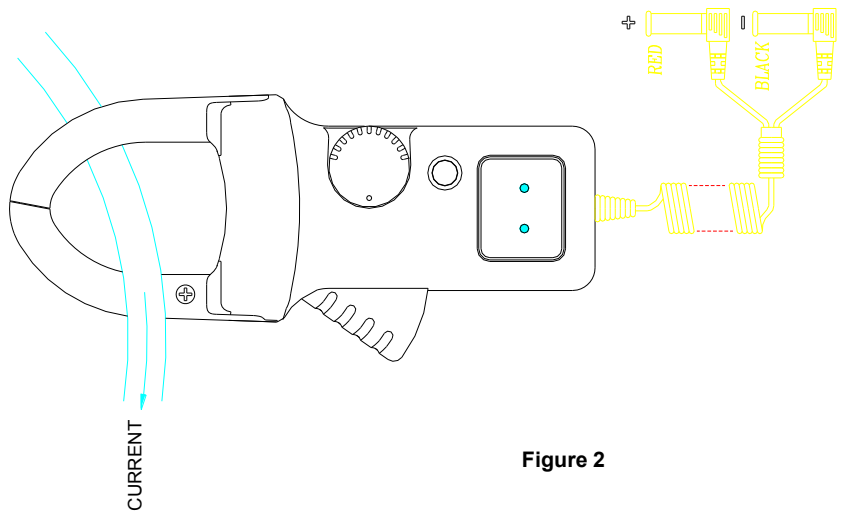

Figure 2

MAINTENANCE

⚠ TO AVOID ELECTRICAL SHOCK REMOVE TEST LEADS BEFORE OPENING THE COVER.

General Maintenance

1. Repairs or servicing not covered in this manual should only be performed by qualified personnel.
2. Periodically wipe the case with a dry cloth and detergent do not use abrasives or solvents.

Battery Installation Replacement

The meter is powered by a single 9V battery. Refer to Figure 3 and use the following procedure to replace the battery.

1. Disconnect the output plus and turn the meter off.
2. Position the adaptor face down and remove the two screws of the case button.
3. Unsnap the case bottom and remove the battery.
4. Install a new 9V battery and refit the case button.

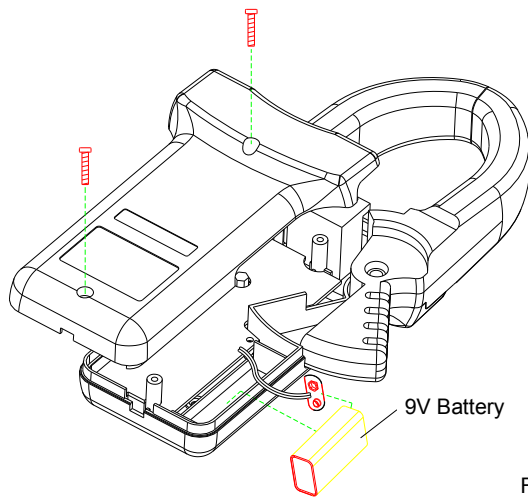

Figure 3

Africa
RS Components SA
P.O. Box 12182, Vorna Valley, 1686
20 Indianapolis Street, Kyalami Business Park,
Kyalami, Midrand
South Africa
www.rs-components.com

China
RS Components Ltd.
Suite 23 A-C , East Sea Business Centre
Phase 2 , No. 618 Yan'an Eastern Road
Shanghai, 200001
China
www.rs-components.com

Japan
RS Components Ltd.
West Tower (12th Floor),
Yokohama Business Park, 134 Godocho, Hodogaya,
Yokohama, Kanagawa 240-0005
Japan
www.rs-components.com

Asia
RS Components Pte Ltd.
31 Tech Park Crescent
Singapore 638040
www.rs-components.com

Europe
RS Components Ltd.
PO Box 99, Corby,
Northants. NN17 9RS
United Kingdom
www.rs-components.com

U.S.A
Allied Electronics
7151 Jack Newell Blvd. S.
Fort Worth, Texas 76118
U.S.A.
www.alliedelec.com

South America
RS Componentes Limitada
Av. Pdte. Eduardo Frei M. 6001-71
Centro Empresas El Cortijo
Conchalí, Santiago, Chile
www.rs-components.com