

Extension module - PLC-V8C/PT-24DC/EM - 2905137

Please be informed that the data shown in this PDF Document is generated from our Online Catalog. Please find the complete data in the user's documentation. Our General Terms of Use for Downloads are valid (<http://phoenixcontact.com/download>)



PLC logic extension logic module with 16 I/Os for plug-in connection to 8 PLC-INTERFACE terminal blocks for extending the basic module (a maximum of two extension modules can be connected to a basic module), push-in connection



Key Commercial Data

Packing unit	1 pc
GTIN	
GTIN	4046356919487

Technical data

Note

Utilization restriction	EMC: class A product, see manufacturer's declaration in the download area
-------------------------	---

Dimensions

Width	50 mm
Height	111 mm
Depth	87 mm

Ambient conditions

Ambient temperature (operation)	-20 °C ... 45 °C
Ambient temperature (storage/transport)	-20 °C ... 70 °C
Max. permissible relative humidity (operation)	95 %
Degree of protection	IP20

Power supply

Supply voltage	24 V DC
Supply voltage range	19.2 V DC ... 26.4 V DC
Maximum input current at U _N	65 mA
Protective circuit	Reverse polarity protection

Extension module - PLC-V8C/PT-24DC/EM - 2905137

Technical data

Power supply

	Surge protection
Status display	Green LED

Input data (digital)

Number of inputs	8 (2 configurable as analog)
Description of the input	EN 61131-2, type 3
Input voltage	24 V DC
Signal level "0" signal	< 5 V
Signal level "1" signal	> 11 V
Input current "0" signal	< 1 mA
Input current "1" signal	typ. 2.5 mA
Status display	Yellow LED

Input data (analog)

Number of inputs	2 (IN6 and IN7 are configurable as analog)
Input voltage range	0 V ... 10 V
Input resistance	> 3.5 kΩ

Input data (PLC-INTERFACE)

Number of inputs	≤ 8
Description of the input	technical data depends on the PLC-INTERFACE terminal block used
Input voltage	19 V DC
Typical current consumption	4 mA
Input resistance	< 100 mΩ

Output data

Number of outputs	≤ 8
Nominal output voltage	24 V DC
Nominal current	9 mA

General

Color	gray
Mounting position	any
Assembly instructions	can be plugged onto 8 x PLC-INTERFACE terminal blocks
Operating mode	100% operating factor
Degree of protection	IP20

Connection data

Connection name	COMBICON connection
Connection method	Push-in connection
Stripping length	9 mm
Number of connections	1
Number of positions	10
Note	Device supply and 8 x inputs

Extension module - PLC-V8C/PT-24DC/EM - 2905137

Technical data

Connection data

Conductor cross section solid	0.14 mm ² ... 1.5 mm ²
Conductor cross section flexible	0.14 mm ² ... 1.5 mm ²
	0.25 mm ² ... 0.5 mm ² (Ferrule with plastic sleeve)
	0.25 mm ² ... 1.5 mm ² (Ferrules without plastic sleeve)
Conductor cross section AWG	26 ... 16

Connection data 2

Connection name	PLC logic - bus
Connection method	Insulation displacement connection
Number of connections	1
Number of positions	4

Standards and Regulations

Designation	Air clearances and creepage distances between the power circuits
Standards/regulations	DIN EN 50178
Rated insulation voltage	50 V
Rated surge voltage	0.8 kV
Insulation	Basic insulation
Degree of pollution	2
Overvoltage category	III
Conformance	CE-compliant

Environmental Product Compliance

China RoHS	Environmentally Friendly Use Period = 50
	For details about hazardous substances go to tab "Downloads", Category "Manufacturer's declaration"

Drawings

Extension module - PLC-V8C/PT-24DC/EM - 2905137

Dimensional drawing

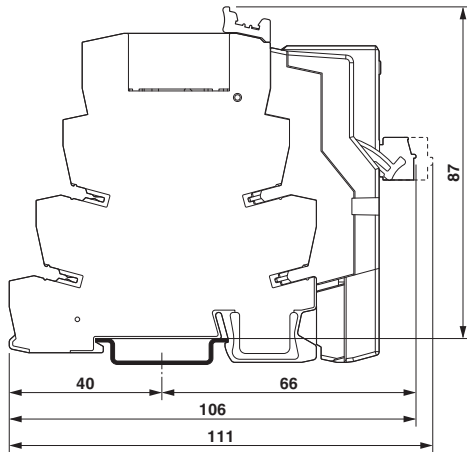

Circuit diagram

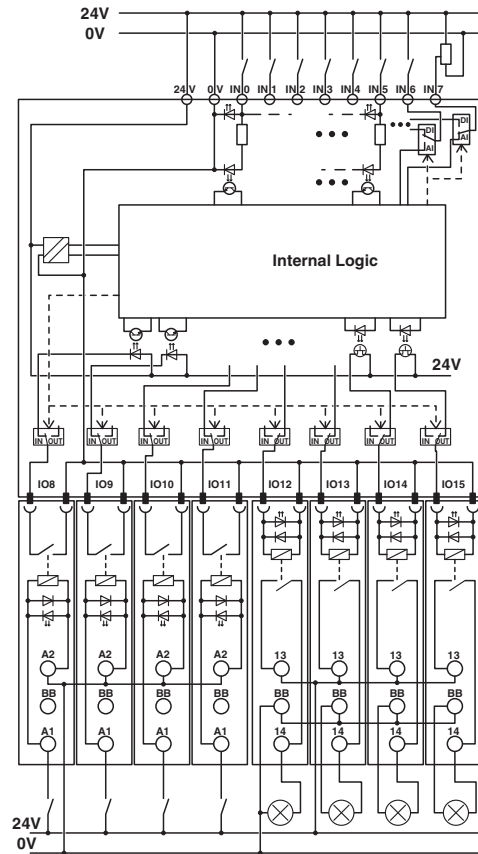

Circuit diagram

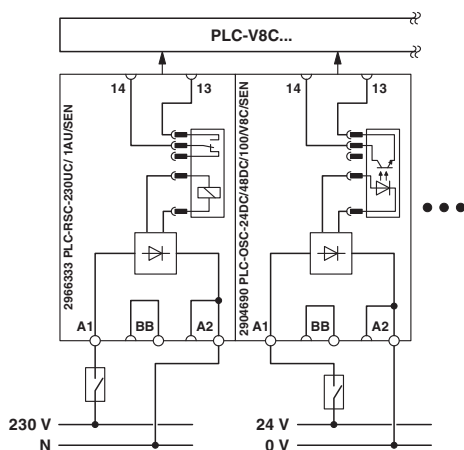

Circuit diagram

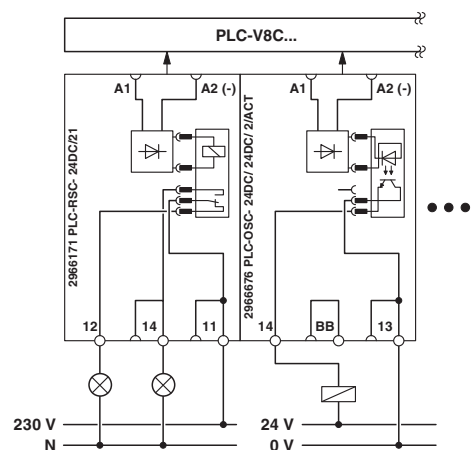

Basic circuit diagram: inputs via PLC-INTERFACE with the example of one input terminal block with relay (230 V AC) and one input terminal block with solid-state relay (24 V DC).

Basic circuit diagram: outputs via PLC-INTERFACE with the example of an output terminal block with relay, 1 PDT, and an output terminal block with solid-state relay.

Extension module - PLC-V8C/PT-24DC/EM - 2905137

Connection diagram

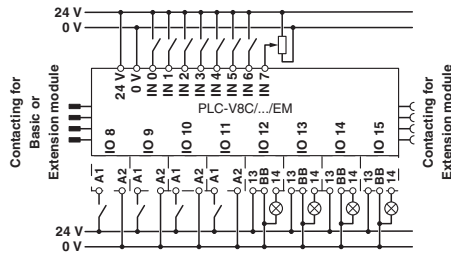

Circuit diagram

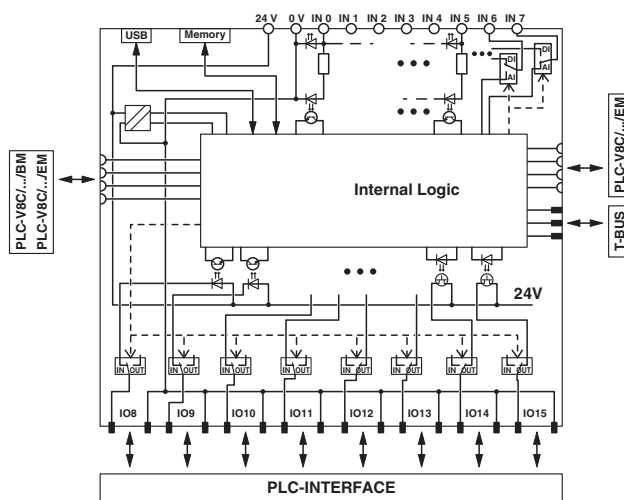

Approvals

Approvals

Approvals

UL Listed / cUL Listed / UL Listed / cUL Listed / EAC / EAC

Ex Approvals

Approval details

UL Listed



<http://database.ul.com/cgi-bin/XYV/template/LISEXT/1FRAME/index.htm>

FILE E 172140

Extension module - PLC-V8C/PT-24DC/EM - 2905137

Approvals

cUL Listed		http://database.ul.com/cgi-bin/XYV/template/LISEXT/1FRAME/index.htm	FILE E 172140
------------	--	---	---------------

UL Listed		http://database.ul.com/cgi-bin/XYV/template/LISEXT/1FRAME/index.htm	FILE E 172140
-----------	--	---	---------------

cUL Listed		http://database.ul.com/cgi-bin/XYV/template/LISEXT/1FRAME/index.htm	FILE E 172140
------------	--	---	---------------

EAC			RU C- DE.A*30.B.01082
-----	--	--	--------------------------

EAC			RU C- DE.A*30.B.01082
-----	--	--	--------------------------

Phoenix Contact 2019 © - all rights reserved
<http://www.phoenixcontact.com>

PHOENIX CONTACT GmbH & Co. KG
Flachsmarktstr. 8
32825 Blomberg
Germany
Tel. +49 5235 300
Fax +49 5235 3 41200
<http://www.phoenixcontact.com>