

Micro Mechanical Valve

VM1000 Series



Miniature structure requires little mounting space.

Built-in hose nipple connection.

Piping options:

Side piping, Bottom piping

Over Travel after actuation (mechanical operated types)



Standard Specifications

Valve type	N.C. poppet				
Number of ports	2 or 3				
Piping	Side or bottom ported				
Fluid	Air				
Operating pressure	0 to 0.8 MPa				
Ambient and fluid temperature	-5 to 60°C (No freezing)				
Flow rate characteristics	Side ported	1(P)-2(A)	0.2	0.15	0.05
		2(A)-3(R)	0.2	0.15	0.05
	Bottom ported	1(P)-2(A)	0.2	0.25	0.05
		2(A)-3(R)	0.2	0.15	0.05
Lubrication	Not required (Use turbine oil Class 1 ISO VG32, if lubricated.)				
Fitting	With hose nipple				

Semi-standard Specification

Total travel (T.T.)	2.5 mm (Basic)
• T.T. 2.5 mm is available for basic type only.	

Model

	Actuator	Piping	Number of ports	Applicable tubing		Note	Weight (g)	
				T0425	TU0425/T0403			
Mechanical operation	Basic	Side ported	3 port	VM1000-4N-00	VM1000-4NU-00	—	6	
			2 port	VM1100-4N-00	VM1100-4NU-00	—		
	Bottom ported	3 port	VM1010-4N-00	VM1010-4NU-00	—			
		2 port	VM1110-4N-00	VM1110-4NU-00	—			
	Roller lever	Side ported	3 port	VM1000-4N-01	VM1000-4NU-01	—		11
			2 port	VM1100-4N-01	VM1100-4NU-01	—		
Bottom ported	3 port	VM1010-4N-01	VM1010-4NU-01	—				
	2 port	VM1110-4N-01	VM1110-4NU-01	—				
One way roller lever	Side ported	3 port	VM1000-4N-02	VM1000-4NU-02	—	12		
		2 port	VM1100-4N-02	VM1100-4NU-02	—			
Bottom ported	3 port	VM1010-4N-02	VM1010-4NU-02	—				
	2 port	VM1110-4N-02	VM1110-4NU-02	—				
Manual operation	Toggle lever	Side ported	3 port	VM1000-4N-08	VM1000-4NU-08	—	20	
			2 port	VM1100-4N-08	VM1100-4NU-08	—		
		Bottom ported	3 port	VM1010-4N-08	VM1010-4NU-08	—		
			2 port	VM1110-4N-08	VM1110-4NU-08	—		
	Push button	Side ported	3 port	VM1000-4N-32R	VM1000-4NU-32R	Red	31	
			2 port	VM1100-4N-32R	VM1100-4NU-32R	Red		
		Bottom ported	3 port	VM1010-4N-32R	VM1010-4NU-32R	Red		
			2 port	VM1110-4N-32R	VM1110-4NU-32R	Red		
		Side ported	3 port	VM1000-4N-32B	VM1000-4NU-32B	Black		
			2 port	VM1100-4N-32B	VM1100-4NU-32B	Black		
		Bottom ported	3 port	VM1010-4N-32B	VM1010-4NU-32B	Black		
			2 port	VM1110-4N-32B	VM1110-4NU-32B	Black		
Side ported	3 port	VM1000-4N-32G	VM1000-4NU-32G	Green				
	2 port	VM1100-4N-32G	VM1100-4NU-32G	Green				
Bottom ported	3 port	VM1010-4N-32G	VM1010-4NU-32G	Green				
	2 port	VM1110-4N-32G	VM1110-4NU-32G	Green				

(Note) To replace the push button and push button cover alone, refer to page 1656.
Other parts and actuator cannot be replaced.

How to Order

VM1 0 0 0 - **4N** - 00

● **Applicable tubing (Material/Size)**

4N	Nylon ø4/2.5 (T0425)
	Nylon ø4/3 (T0403)
4NU	Soft Nylon ø4/2.5 (TS0425)
	Polyurethane ø4/2.5 (TU0425)

● **Total travel/Basic (T.T.)**

0	4.8 mm
1	2.5 mm (Option)* = Basic only.

● **Piping**

0	Side ported
1	Bottom ported

● **Number of ports**

0	3 port
1	2 port

● **Actuator type*1**

00	Basic
01	Roller lever
02	One way roller lever
08	Toggle lever
32	Push button

● **Color of push button*1**

R	Red
G	Green
B	Black

*1 For details on the color variations for the actuator with push button, refer to Model on page 1582.

Construction

Side ported/Non-actuated

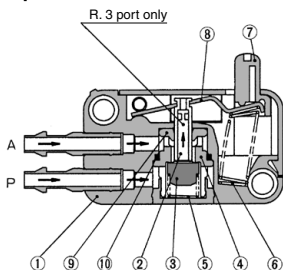

Side ported/Actuated

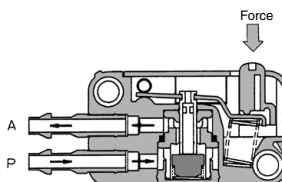

Bottom ported/Non-actuated

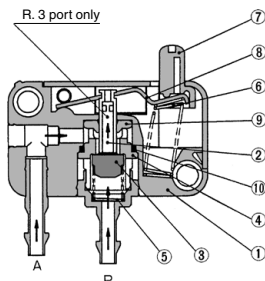

Bottom ported/Actuated

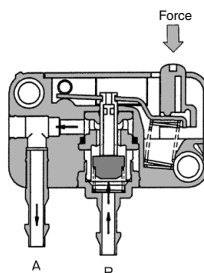

Component Parts

No.	Description	Material	Note
1	Body	PBT	
2	Valve	POM	
3	Valve	NBR	
4	Retainer	POM	
5	Valve return spring	Stainless steel	

No.	Description	Material	Note
6	Lever return spring	Stainless steel	
7	Plunger	POM	T.T. = 2.5 mm only, w/threads
8	Lever	Stainless steel	
9	Packing	NBR	
10	O-ring	NBR	

- VM**
- VMG**
- VR**
- VR51**
- VHK**
- VH**
- VHS**
- VHS**

VM1000 Series

VM1000 Series/Side Ported

Basic

VM1000-4N-00
VM1000-4NU-00
VM1100-4N-00
VM1100-4NU-00

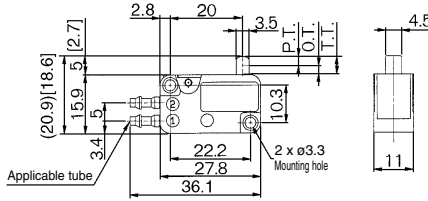

[]: T.T. = 2.5 mm

Symbol/2 port

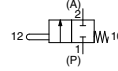

3 port

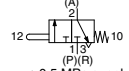

* 0.5 MPa supply

		Applicable tubing	
		T0425	TU0425, T0403, TS0425
Side ported	3 port	VM1000-4N-00	VM1000-4NU-00
	2 port	VM1100-4N-00	VM1100-4NU-00
F.O.F.*		6 N	
P.T.		2.5mm[2mm]	
O.T.		2.3mm[0.5mm]	
T.T.		4.8mm[2.5mm]	

Roller lever

VM1000-4N-01
VM1000-4NU-01
VM1100-4N-01
VM1100-4NU-01

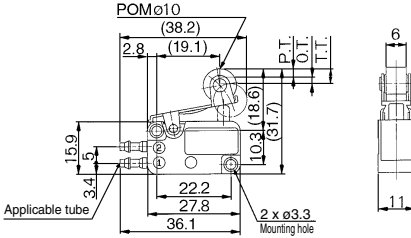

Symbol/2 port

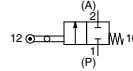

3 port

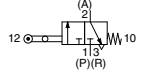

* 0.5 MPa supply

		Applicable tubing	
		T0425	TU0425, T0403, TS0425
Side ported	3 port	VM1000-4N-01	VM1000-4NU-01
	2 port	VM1100-4N-01	VM1100-4NU-01
F.O.F.*		6 N	
P.T.		2.5 mm	
O.T.		2.0 mm	
T.T.		4.5 mm	

One way roller lever

VM1000-4N-02
VM1000-4NU-02
VM1100-4N-02
VM1100-4NU-02

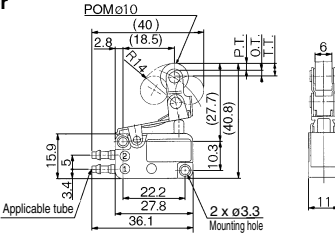

Symbol/2 port

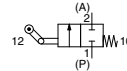

3 port

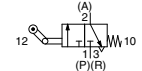

* 0.5 MPa supply

		Applicable tubing	
		T0425	TU0425, T0403, TS0425
Side ported	3 port	VM1000-4N-02	VM1000-4NU-02
	2 port	VM1100-4N-02	VM1100-4NU-02
F.O.F.*		6 N	
P.T.		2.5 mm	
O.T.		2.0 mm	
T.T.		4.5 mm	

Toggle lever

VM1000-4N-08
VM1000-4NU-08
VM1100-4N-08
VM1100-4NU-08

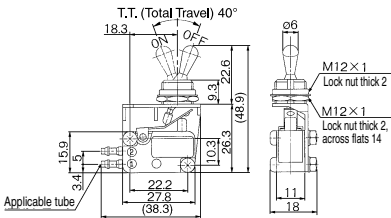

Panel mounting hole

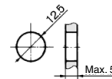

Symbol/2 port

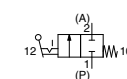

3 port

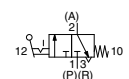

* 0.5 MPa supply

		Applicable tubing	
		T0425	TU0425, T0403, TS0425
Side ported	3 port	VM1000-4N-08	VM1000-4NU-08
	2 port	VM1100-4N-08	VM1100-4NU-08
F.O.F.*		4N	
P.T.		40°	

Push button

VM1000-4N-32
VM1000-4NU-32
VM1100-4N-32
VM1100-4NU-32

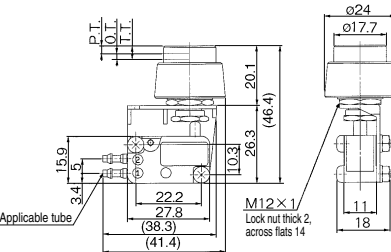

Panel mounting hole

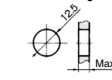

Symbol/2 port

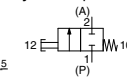

3 port

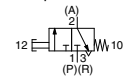

* 0.5 MPa supply

		Applicable tubing	
		T0425	TU0425, T0403, TS0425
Side ported	3 port	VM1000-4N-32	VM1000-4NU-32
	2 port	VM1100-4N-32	VM1100-4NU-32
F.O.F.*		6 N	
P.T.		2.5 mm	
O.T.		2.0 mm	
T.T.		4.5 mm	

VM1000 Series/Bottom Ported

Basic

- VM1010-4N-00
- VM1010-4NU-00
- VM1110-4N-00
- VM1110-4NU-00



[]: T.T. = 2.5 mm

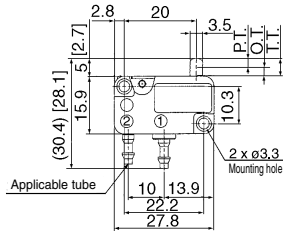

Symbol/2 port

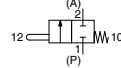

3 port

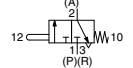

= 0.5 MPa supply

		Applicable tubing	
		T0425	TU0425, T0403, TS0425
Bottom ported	3 port	VM1010-4N-00	VM1010-4NU-00
	2 port	VM1110-4N-00	VM1110-4NU-00
F.O.F.*		6 N	
P.T.		2.5 mm	
O.T.		2.3mm[0.5mm]	
T.T.		4.8mm[2.5mm]	

Roller lever

- VM1010-4N-01
- VM1010-4NU-01
- VM1110-4N-01
- VM1110-4NU-01

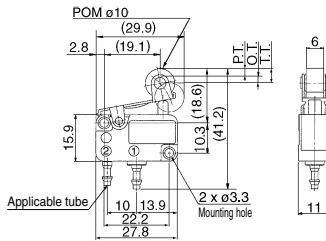

Symbol/2 port

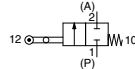

3 port

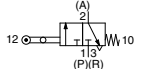

= 0.5 MPa supply

		Applicable tubing	
		T0425	TU0425, T0403, TS0425
Bottom ported	3 port	VM1010-4N-01	VM1010-4NU-01
	2 port	VM1110-4N-01	VM1110-4NU-01
F.O.F.*		6 N	
P.T.		2.5 mm	
O.T.		2.0 mm	
T.T.		4.5 mm	

One way roller lever

- VM1010-4N-02
- VM1010-4NU-02
- VM1110-4N-02
- VM1110-4NU-02

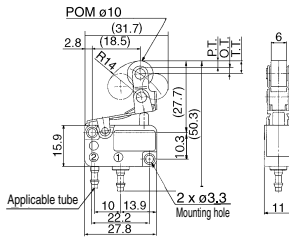

Symbol/2 port

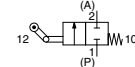

3 port

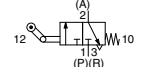

= 0.5 MPa supply

		Applicable tubing	
		T0425	TU0425, T0403, TS0425
Bottom ported	3 port	VM1010-4N-02	VM1010-4NU-02
	2 port	VM1110-4N-02	VM1110-4NU-02
F.O.F.*		6 N	
P.T.		2.5 mm	
O.T.		2.0 mm	
T.T.		4.5 mm	

Toggle lever

- M1010-4N-08
- VM1010-4NU-08
- VM1110-4N-08
- VM1110-4NU-08

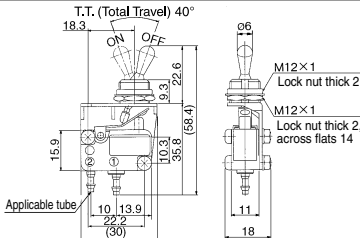

Panel mounting hole Symbol/2 port

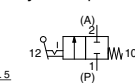
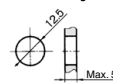

3 port

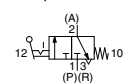

= 0.5 MPa supply

		Applicable tubing	
		T0425	TU0425, T0403, TS0425
Bottom ported	3 port	VM1010-4N-08	VM1010-4NU-08
	2 port	VM1110-4N-08	VM1110-4NU-08
F.O.F.*		4N	
P.T.		40°	

Push button

- VM1010-4N-32
- VM1010-4NU-32
- VM1110-4N-32
- VM1110-4NU-32

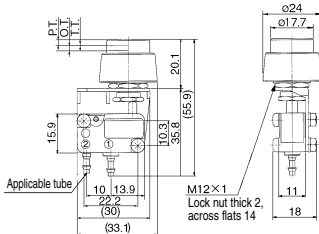

Panel mounting hole Symbol/2 port

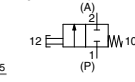
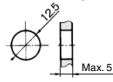

3 port

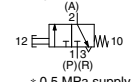

= 0.5 MPa supply

		Applicable tubing	
		T0425	TU0425, T0403, TS0425
Bottom ported	3 port	VM1010-4N-32	VM1010-4NU-32
	2 port	VM1110-4N-32	VM1110-4NU-32
F.O.F.*		6 N	
P.T.		2.5 mm	
O.T.		2.0 mm	
T.T.		4.5 mm	

2/3 Port Mechanical Valve

VM100/200 Series

RoHS

Lightweight

VM100 60 g* (Current model: 95 g)

VM200 90 g* (Current model: 111 g)

* Side ported, basic type

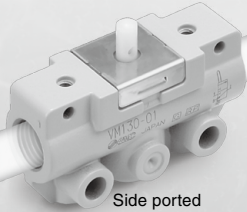

Side ported



Bottom ported

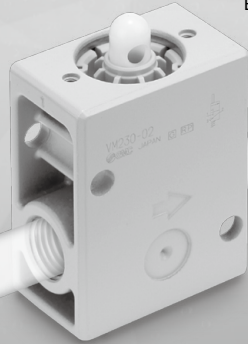

Mounting interchangeable
with the current model

Available in vacuum
applications (VM100)

-100 kPa to 1 MPa

(VM200: 0 to 1 MPa)

Mounting

Bracket mounting and bottom mounting are newly added.

Bracket mounting



Bottom mounting (Side ported only)

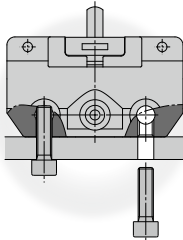

Side mounting

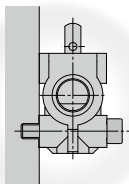

Panel mounting

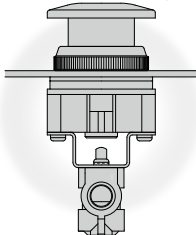

Piping direction

Side ported

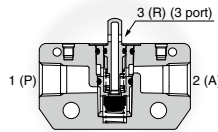

Bottom ported (VM100 only)

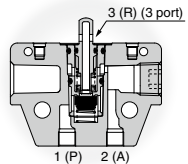

With miniature indicator* Possible to check if air is output to the secondary port.

* VM100/Bottom ported only

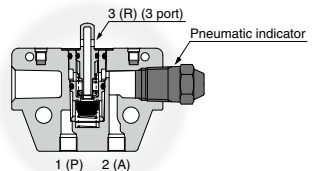

Actuator Variations

* It is possible to change the actuator assembly and mount to basic type.

Mechanical Operation

Roller lever

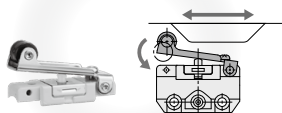

One way roller lever

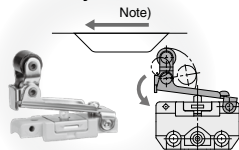

Note) If operated (by cam or dog) in the opposite direction, the valve will not be opened.

Straight plunger*

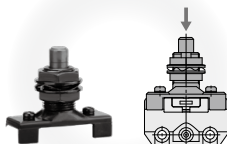

Roller plunger*

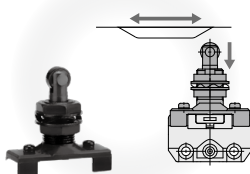

Cross roller plunger*

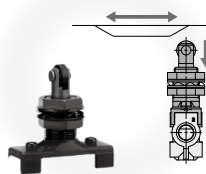

Manual Operation

Toggle lever*

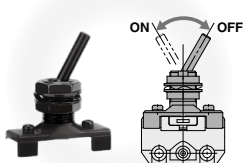

Push button (Mushroom)*

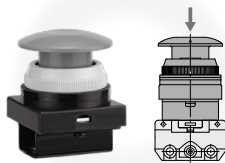

Color: Red, Black, Green, Yellow

Push button (Extended)*

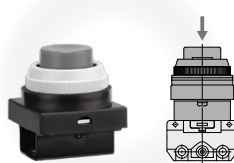

Color: Red, Black, Green, Yellow

Push button (Flush)*



Color: Red, Black, Green, Yellow

Twist selector (2 position)*



Color: Red, Black, Green, Yellow

Key selector (2 position)



Twist selector (3 position)



Color: Red, Black, Green, Yellow

Foot pedal (VM200 only)

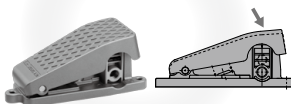

4 colors available for buttons



Push button (Flush) is provided with a set of 4 colors.

VM

VMG

VR

VR51

VHK

VH

VHS

VHS

2/3 Port Mechanical Valve

VM100 Series



- Compact size
- Piping options:
Side ported, Bottom ported
- Possible to choose mounting method with side ported:
Side mounting, bottom mounting using screws, or mounting with special bracket
- A variety of actuator types

Specifications

Piping	Side ported	Bottom ported			
Fluid	Air				
Operating pressure range	-100 kPa to 1 MPa				
Ambient and fluid temperature	-5 to 60°C (No freezing)				
Flow rate characteristics	1 (P) ⇒ 2 (A) 2 (A) ⇒ 3 (R)	1 (P) ⇒ 2 (A)	2 (A) ⇒ 3 (R)		
C [dm ³ /(s·bar)]	b	0.6	0.5	0.5	0.45
	b	0.2	0.15	0.2	0.15
	Cv	0.11	0.1	0.11	0.1
Lubrication ^{Note 1)}	Not required				
Port size	1/8 (Rc, NPT, G)	M5			
Weight (Basic)	60 g	67 g			
Bracket part number ^{Note 2)}	VM1-B	—			

Note 1) Use turbine oil Class 1 ISO VG32, if lubricated.

Note 2) The bracket can only be used for side mounting of side ported type.



Model

	Piping direction		Side ported				Bottom ported		Actuator	
	Body option		Standard		With bottom mounting thread		—		Actuator part number	Additional weight for actuator
	Number of ports		2 port	3 port	2 port	3 port	2 port	3 port		
Mechanical operation	Basic		VM120-01-00A	VM130-01-00A	VM120U-01-00A	VM130U-01-00A	VM122-M5-00A	VM132-M5-00A	—	—
	Roller lever	Polyacetal roller	VM121-01-01A	VM131-01-01A	VM121U-01-01A	VM131U-01-01A	VM123-M5-01A	VM133-M5-01A	—	11 g
		Hard steel roller	VM121-01-01SA	VM131-01-01SA	VM121U-01-01SA	VM131U-01-01SA	VM123-M5-01SA	VM133-M5-01SA	—	16 g
	One way roller lever	Polyacetal roller	VM121-01-02A	VM131-01-02A	VM121U-01-02A	VM131U-01-02A	VM123-M5-02A	VM133-M5-02A	—	15 g
		Hard steel roller	VM121-01-02SA	VM131-01-02SA	VM121U-01-02SA	VM131U-01-02SA	VM123-M5-02SA	VM133-M5-02SA	—	20 g
	Straight plunger		VM120-01-05A	VM130-01-05A	VM120U-01-05A	VM130U-01-05A	VM122-M5-05A	VM132-M5-05A	VM-05B	43 g
	Roller plunger	Polyacetal roller	VM120-01-06A	VM130-01-06A	VM120U-01-06A	VM130U-01-06A	VM122-M5-06A	VM132-M5-06A	VM-06B	43 g
		Hard steel roller	VM120-01-06SA	VM130-01-06SA	VM120U-01-06SA	VM130U-01-06SA	VM122-M5-06SA	VM132-M5-06SA	VM-06BS	45 g
	Cross roller plunger	Polyacetal roller	VM120-01-07A	VM130-01-07A	VM120U-01-07A	VM130U-01-07A	VM122-M5-07A	VM132-M5-07A	VM-07B	43 g
		Hard steel roller	VM120-01-07SA	VM130-01-07SA	VM120U-01-07SA	VM130U-01-07SA	VM122-M5-07SA	VM132-M5-07SA	VM-07BS	45 g
Toggle lever		VM120-01-08A	VM130-01-08A	VM120U-01-08A	VM130U-01-08A	VM122-M5-08A	VM132-M5-08A	VM-08B	41 g	
Manual operation	Push button (Mushroom)	Red	VM120-01-30RA	VM130-01-30RA	VM120U-01-30RA	VM130U-01-30RA	VM122-M5-30RA	VM132-M5-30RA	VM-30AR	58 g
		Black	VM120-01-30BA	VM130-01-30BA	VM120U-01-30BA	VM130U-01-30BA	VM122-M5-30BA	VM132-M5-30BA	VM-30AB	
		Green	VM120-01-30GA	VM130-01-30GA	VM120U-01-30GA	VM130U-01-30GA	VM122-M5-30GA	VM132-M5-30GA	VM-30AG	
		Yellow	VM120-01-30YA	VM130-01-30YA	VM120U-01-30YA	VM130U-01-30YA	VM122-M5-30YA	VM132-M5-30YA	VM-30AY	
		Red	VM120-01-32RA	VM130-01-32RA	VM120U-01-32RA	VM130U-01-32RA	VM122-M5-32RA	VM132-M5-32RA	VM-32AR	
Black	VM120-01-32BA	VM130-01-32BA	VM120U-01-32BA	VM130U-01-32BA	VM122-M5-32BA	VM132-M5-32BA	VM-32AB			
Green	VM120-01-32GA	VM130-01-32GA	VM120U-01-32GA	VM130U-01-32GA	VM122-M5-32GA	VM132-M5-32GA	VM-32AG			
Yellow	VM120-01-32YA	VM130-01-32YA	VM120U-01-32YA	VM130U-01-32YA	VM122-M5-32YA	VM132-M5-32YA	VM-32AY			
Push button (Flush)		With a set of red, black, green, yellow	VM120-01-33A	VM130-01-33A	VM120U-01-33A	VM130U-01-33A	VM122-M5-33A	VM132-M5-33A	VM-33A	50 g
Twist selector (2 position)	Key selector (2 position)	Red	VM120-01-34RA	VM130-01-34RA	VM120U-01-34RA	VM130U-01-34RA	VM122-M5-34RA	VM132-M5-34RA	VM-34AR	56 g
		Black	VM120-01-34BA	VM130-01-34BA	VM120U-01-34BA	VM130U-01-34BA	VM122-M5-34BA	VM132-M5-34BA	VM-34AB	
		Green	VM120-01-34GA	VM130-01-34GA	VM120U-01-34GA	VM130U-01-34GA	VM122-M5-34GA	VM132-M5-34GA	VM-34AG	
		Yellow	VM120-01-34YA	VM130-01-34YA	VM120U-01-34YA	VM130U-01-34YA	VM122-M5-34YA	VM132-M5-34YA	VM-34AY	
		Red	VM131-01-35RA	VM151-01-35RA	VM131U-01-35RA	VM151U-01-35RA	VM133-M5-35RA	VM153-M5-35RA	—	
Black	VM131-01-35BA	VM151-01-35BA	VM131U-01-35BA	VM151U-01-35BA	VM133-M5-35BA	VM153-M5-35BA	—			
Green	VM131-01-35GA	VM151-01-35GA	VM131U-01-35GA	VM151U-01-35GA	VM133-M5-35GA	VM153-M5-35GA	—			
Yellow	VM131-01-35YA	VM151-01-35YA	VM131U-01-35YA	VM151U-01-35YA	VM133-M5-35YA	VM153-M5-35YA	—			
Twist selector (3 position)		3 port	5 port	3 port	5 port	3 port	5 port			

Note 1) It is possible to change the actuator assembly and mount to basic type when an actuator part number is specified in the column.

Note 2) For push button (mushroom), push button (flush), push button (extended) and individual fastening ring, refer to page 1612.

Note 3) The handle of the selector (2 position and 3 position) cannot be removed or replaced alone.

Note 4) Color of plunger: Gray (2 port), White (3 port)

How to Order

VM1 3 1 [] - 01 - 01 [] [] A - [] - []

Number of ports

2	2 port
3	3 port
5	5 port (Twist selector 3 position only)

Piping direction and the height of plunger

0	Side ported	Long
1	Side ported	Short
2	Bottom ported	Long
3	Bottom ported	Short

Body option

Nil	Side mounting
U	With bottom mounting thread

Note) U: Applicable only to side ported type

Port size

01	Rc1/8	
N01	NPT1/8	Side ported only
F01	G1/8	
M5	M5 x 0.8	Bottom ported only

Actuator type*

Actuator type	Side ported		Bottom ported	
	Long	Short	Long	Short
00	Basic	○	○	○
01	Roller lever	×	○	×
02	One way roller lever	×	○	×
05	Straight plunger	○	×	○
06	Roller plunger	○	×	×
07	Cross roller plunger	○	×	×
08	Toggle lever	○	×	×
30	Push button (Mushroom)	○	×	×
32	Push button (Extended)	○	×	×
33	Push button (Flush)	○	×	×
34	Twist selector (2 position)	○	×	×
36	Key selector (2 position)	○	×	×
35	Twist selector (3 position)	×	○	×

Combination possible: ○ Combination impossible: ×

Made to Order (Pages 1608, 1609)

X207	Alternate type, Mushroom push button
X219	Push-lock turn-reset type, Mushroom push button

Note) Applicable only to push button (mushroom)

Bracket option

Nil	None
B	With bracket

Note) Applicable only to side ported, side mounting type. However, not applicable to twist selector (3 position). Bracket is shipped together, but not assembled.

Suffix for indicator

Nil	None
Z	With miniature indicator

Note) Applicable only to bottom ported type

Suffix for actuator*

S	Hard steel roller
R	Red
B	Black
G	Green
Y	Yellow

Color of push button, selector

* Refer to the table on page 1588 for combinations of actuator type and suffix.

Construction

Side ported

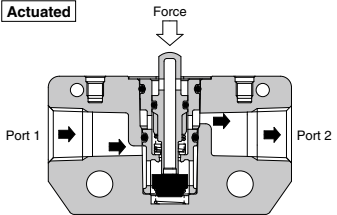
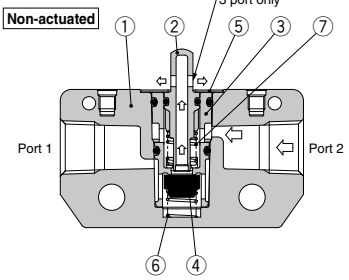

Bottom ported

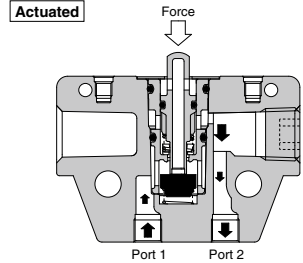
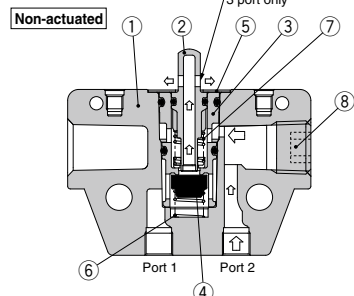

Component Parts

No.	Description	Material	Note
1	Valve	ZDC	White coated
2	Plunger	Polyacetal	2 port Gray
			3 port White
3	Valve sheet	PBT	
4	Valve	NBR	

No.	Description	Material	Note
5	Plunger retainer	Stainless steel	
6	Spring	Stainless steel	
7	Spring	Spring steel	
8	Hexagon socket head taper plug	Rolled steel	

- VM
- VMG
- VR
- VR51
- VHK
- VH
- VHS □
- VHS

VM100 Series/Side Ported

Roller plunger
 VM120-01-06A
 VM130-01-06A
 VM120-01-06SA
 VM130-01-06SA

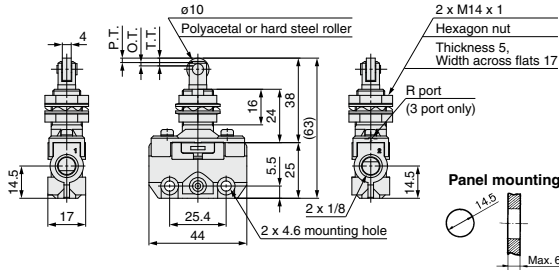

Symbol

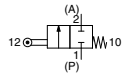

2 port

3 port

* 0.5 MPa supply	
F.O.F.*	29 N
P.T.	2 mm
O.T.	1.5 mm
T.T.	3.5 mm

Cross roller plunger
 VM120-01-07A
 VM130-01-07A
 VM120-01-07SA
 VM130-01-07SA

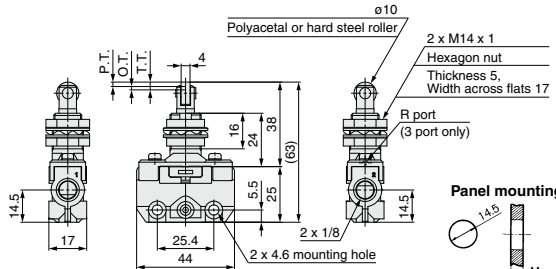

Symbol

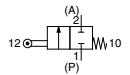

2 port

3 port

* 0.5 MPa supply	
F.O.F.*	29 N
P.T.	2 mm
O.T.	1.5 mm
T.T.	3.5 mm

Toggle lever
 VM120-01-08A
 VM130-01-08A

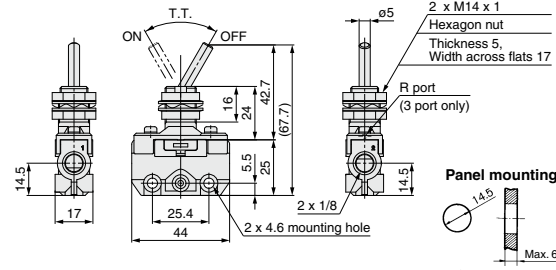

Symbol

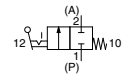

2 port

3 port

* 0.5 MPa supply	
F.O.F.*	13 N
T.T.	60°

Push button (Mushroom)
 VM120-01-30 (R, B, G, Y) A
 VM130-01-30 (R, B, G, Y) A

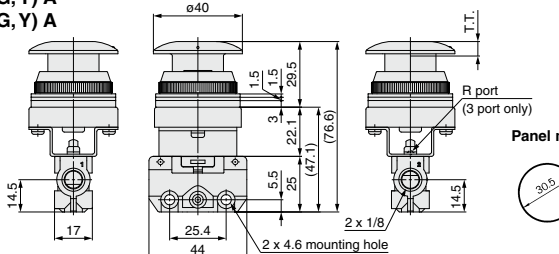

Symbol

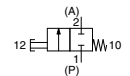

2 port

3 port

* 0.5 MPa supply	
F.O.F.*	27 N
T.T.	6.5 mm

VM100 Series

VM100 Series/Side Ported

Push button (Extended)
 VM120-01-32 (R, B, G, Y) A
 VM130-01-32 (R, B, G, Y) A

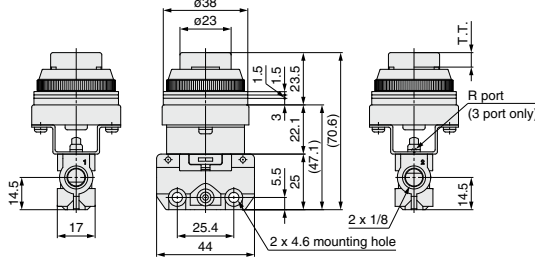

Panel mounting hole

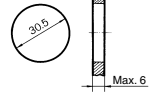

Symbol

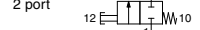

3 port

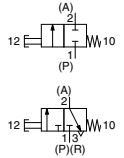

* 0.5 MPa supply

F.O.F.*	27 N
T.T.	6.5 mm

Push button (Flush)
 VM120-01-33A
 VM130-01-33A

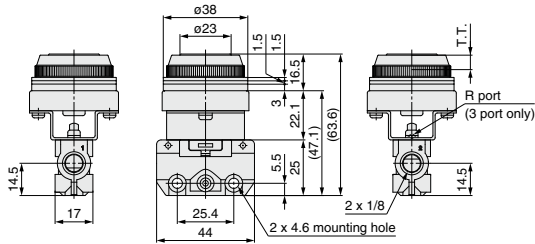

Panel mounting hole

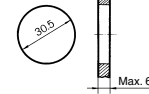

Symbol

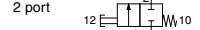

3 port

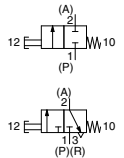

* 0.5 MPa supply

F.O.F.*	27 N
T.T.	6.5 mm

Twist selector (2 position)
 VM120-01-34 (R, B, G, Y) A
 VM130-01-34 (R, B, G, Y) A

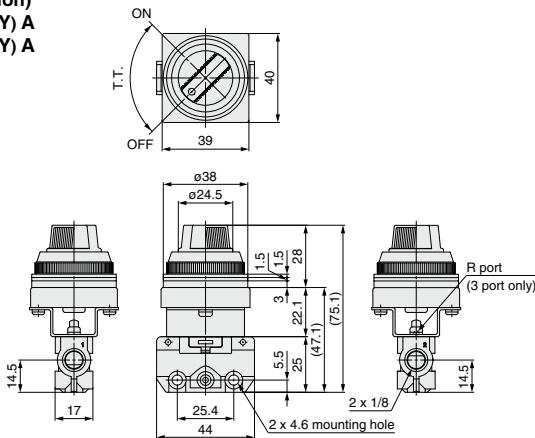

Panel mounting hole

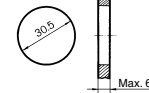

Symbol

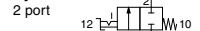

3 port

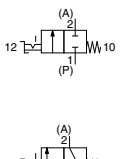

* 0.5 MPa supply

F.O.F.*	15 N
T.T.	90°

VM100 Series/Side Ported

Key selector (2 position)

VM120-01-36A

VM130-01-36A

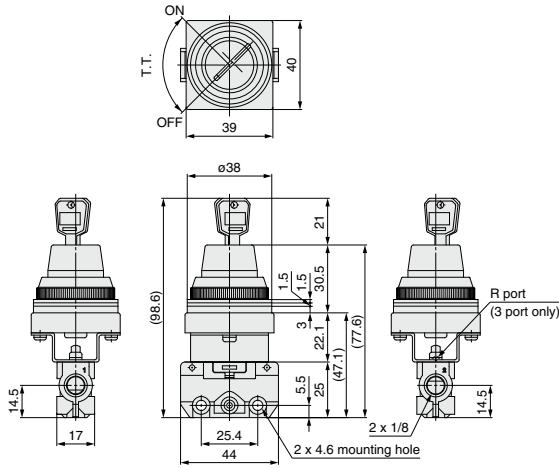

Panel mounting hole

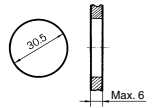

Symbol

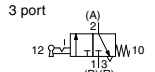
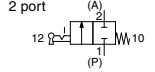

Key can be removed at the "on" and "off" positions.
One spare key is included.

* 0.5 MPa supply

F.O.F.*	15 N
T.T.	90°

Twist selector (3 position)

VM131-01-35 (R, B, G, Y) A

VM151-01-35 (R, B, G, Y) A

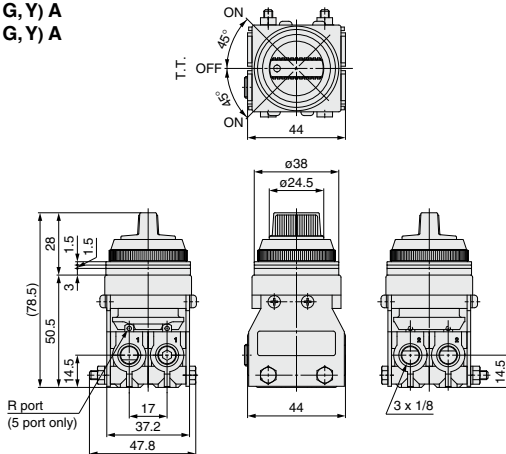

Panel mounting hole

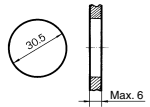

Symbol

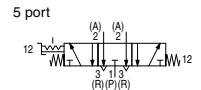
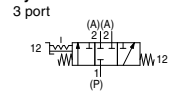

* 0.5 MPa supply

F.O.F.*	20 N
T.T.	45°

VM

VMG

VR

VR51

VHK

VH

VHS

VHS

VM100 Series

VM100 Series/Side Ported

With bracket

- VM120-01-□A-B
- VM130-01-□A-B
- VM121-01-□A-B
- VM131-01-□A-B

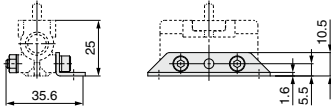
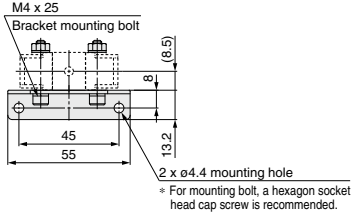

VM1-B

Component parts	Q'ty
Bracket	1
Hexagon socket head cap screw M4 x 25	2
Hexagon nut M4	2

With bottom mounting thread

- VM120U-01-□A
- VM130U-01-□A
- VM121U-01-□A
- VM131U-01-□A

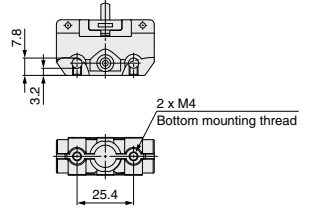

- VM131U-01-35□A
- VM151U-01-35□A

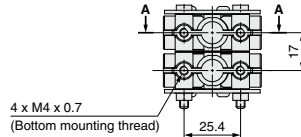
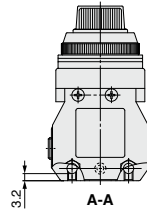

VM100 Series/Bottom Ported

Basic

- VM122-M5-00A
- VM132-M5-00A
- VM123-M5-00A
- VM133-M5-00A

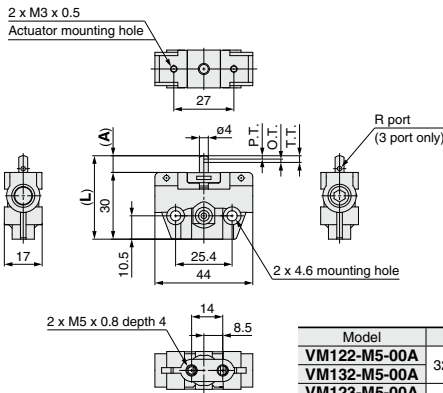

Symbol

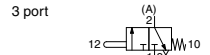
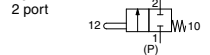

With miniature indicator

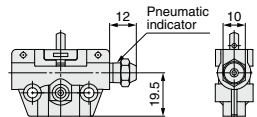

Model	L	A
VM122-M5-00A	32.5	7.5
VM132-M5-00A	28.5	3.5

* 0.5 MPa supply	
F.O.F. ^①	26 N
P.T.	1.5 mm
O.T.	1.5 mm
T.T.	3 mm

Roller lever

- VM123-M5-01A
- VM133-M5-01A
- VM123-M5-01SA
- VM133-M5-01SA

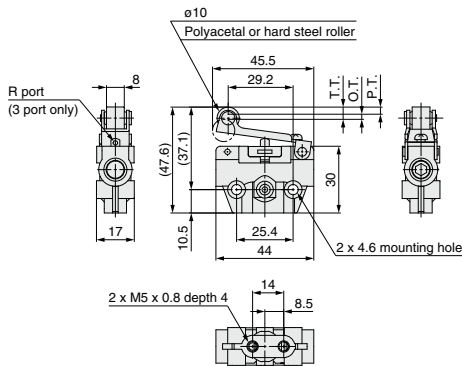

Symbol

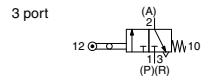
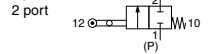

* 0.5 MPa supply	
F.O.F. ^①	13 N
P.T.	3.2 mm
O.T.	2.3 mm
T.T.	5.5 mm

One way roller lever

- VM123-M5-02A
- VM133-M5-02A
- VM123-M5-02SA
- VM133-M5-02SA

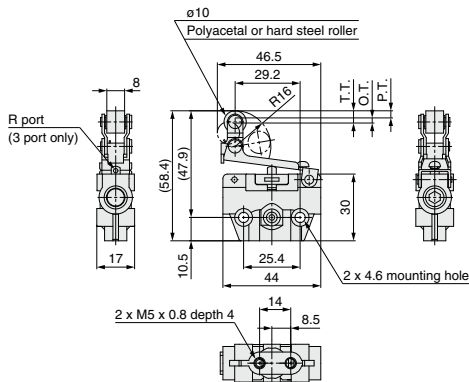

Symbol

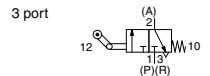
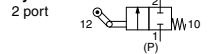

* 0.5 MPa supply	
F.O.F. ^①	13 N
P.T.	3.2 mm
O.T.	2.3 mm
T.T.	5.5 mm

VM100 Series

VM100 Series/Bottom Ported

Straight plunger
VM122-M5-05A
VM132-M5-05A

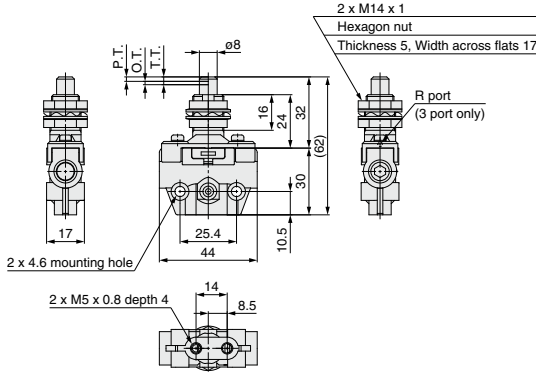

Panel mounting hole

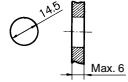

Symbol

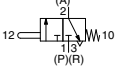
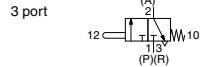
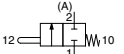
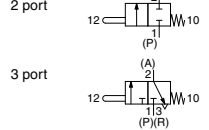

* 0.5 MPa supply

F.O.F. ^{*)}	29 N
P.T.	2 mm
O.T.	1.5 mm
T.T.	3.5 mm

Roller plunger
VM122-M5-06A
VM132-M5-06A
VM122-M5-06SA
VM132-M5-06SA

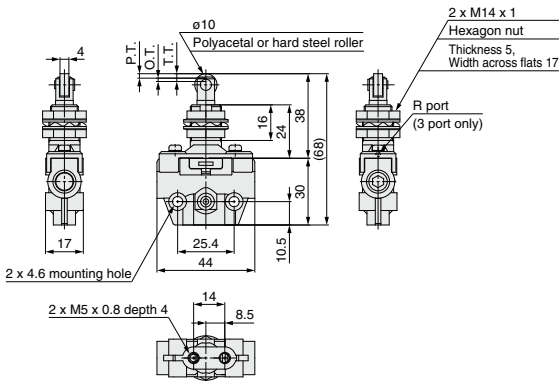

Panel mounting hole

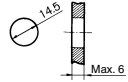

Symbol

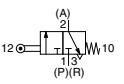
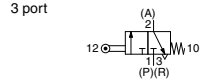
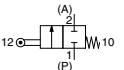
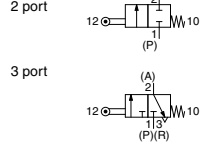

* 0.5 MPa supply

F.O.F. ^{*)}	29 N
P.T.	2 mm
O.T.	1.5 mm
T.T.	3.5 mm

Cross roller plunger
VM122-M5-07A
VM132-M5-07A
VM122-M5-07SA
VM132-M5-07SA

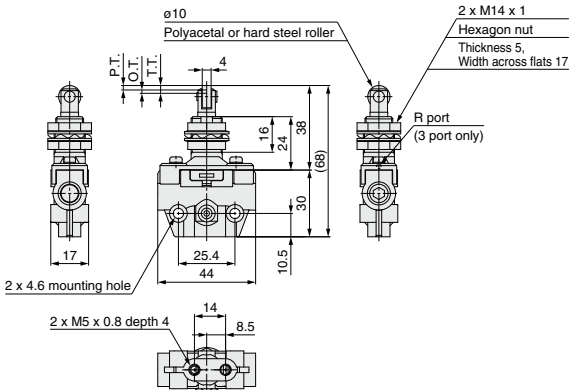

Panel mounting hole

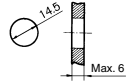

Symbol

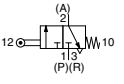
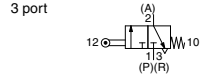
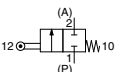
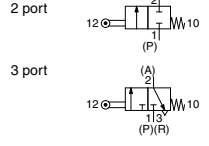

* 0.5 MPa supply

F.O.F. ^{*)}	29 N
P.T.	2 mm
O.T.	1.5 mm
T.T.	3.5 mm

VM100 Series/Bottom Ported

Toggle lever
VM122-M5-08A
VM132-M5-08A

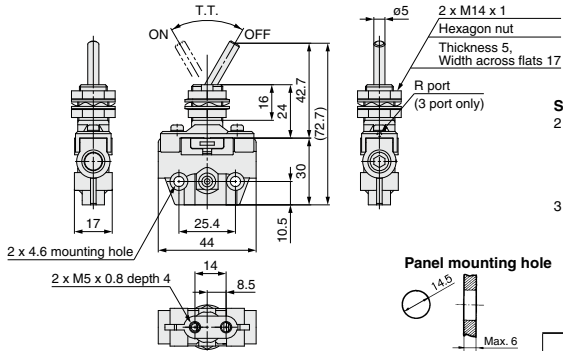

Symbol

2 port

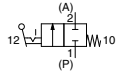

3 port

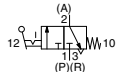

Panel mounting hole

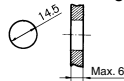

* 0.5 MPa supply

F.O.F. ^{*)}	13 N
T.T.	60°

Push button (Mushroom)
VM122-M5-30 (R, B, G, Y) A
VM132-M5-30 (R, B, G, Y) A

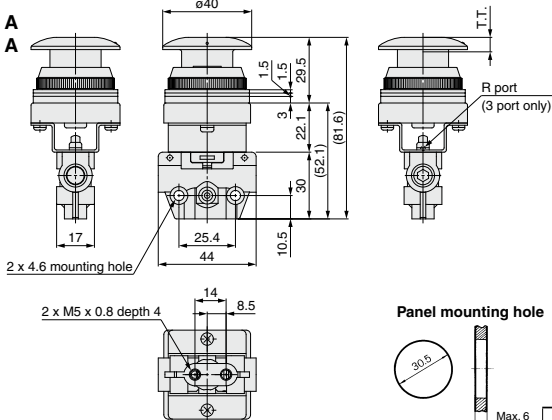

Symbol

2 port

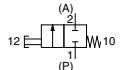

3 port

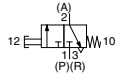

Panel mounting hole

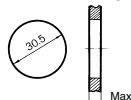

* 0.5 MPa supply

F.O.F. ^{*)}	27 N
T.T.	6.5 mm

Push button (Extended)
VM122-M5-32 (R, B, G, Y) A
VM132-M5-32 (R, B, G, Y) A

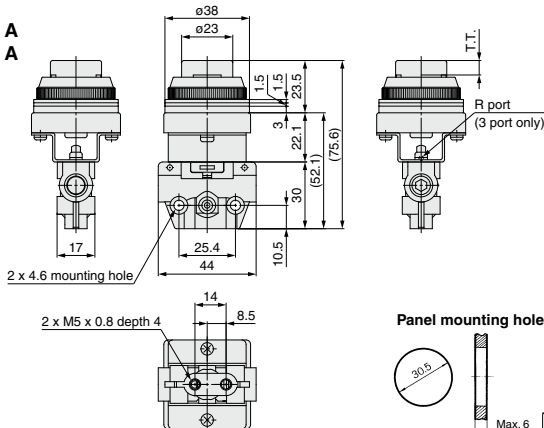

Symbol

2 port

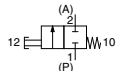

3 port

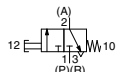

Panel mounting hole

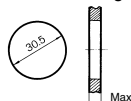

* 0.5 MPa supply

F.O.F. ^{*)}	27 N
T.T.	6.5 mm

VM100 Series/Bottom Ported

Key selector (2 position)

VM122-M5-36A
VM132-M5-36A

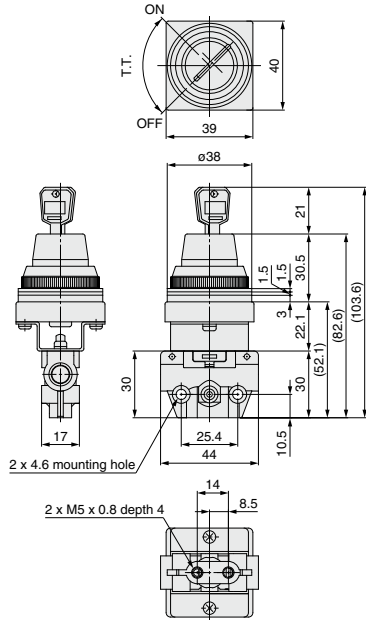

Panel mounting hole

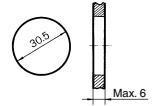

R port
(3 port only)

Symbol
2 port

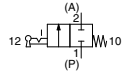

3 port

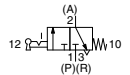

Key can be removed at the "on" and "off" positions.
One spare key is included.

* 0.5 MPa supply

F.O.F.*	15 N
T.T.	90°

Twist selector (3 position)

VM133-M5-35 (R, B, G, Y) A
VM153-M5-35 (R, B, G, Y) A

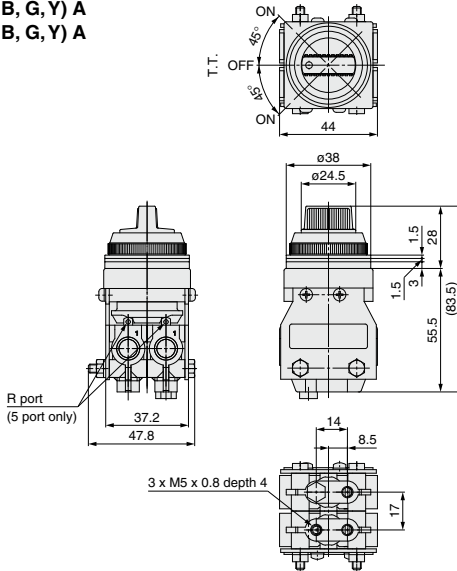

Panel mounting hole

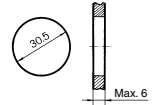

Symbol
3 port

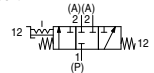

5 port

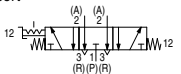

* 0.5 MPa supply

F.O.F.*	20 N
T.T.	45°

2/3 Port Mechanical Valve VM200 Series



- Large flow capacity
- Possible to choose mounting method:
Side mounting, bottom mounting using screws, or mounting with special bracket
- A variety of actuator types



Specifications

Fluid	Air	
Operating pressure range	0 to 1 MPa	
Ambient and fluid temperature	-5 to 60°C (No freezing)	
Flow rate characteristics	1 (P) ⇒ 2 (A)	2 (A) ⇒ 3 (R)
C [dm ³ /(s·bar)]	4	3.5
	b	0.4
	Cv	0.87
Lubrication ^{Note 1)}	Not required	
Port size	1/4	
Weight (Basic)	90 g	
Bracket part number ^{Note 2)}	VM2-B	

Note 1) Use turbine oil Class 1 ISO VG32, if lubricated.

Note 2) The bracket can only be used for side mounting.

Model

	Piping direction		Side ported				Actuator	
	Body option		Standard		With bottom mounting thread		Actuator part number	Additional weight for actuator
	Number of ports		2 port	3 port	2 port	3 port		
Mechanical operation	Basic		VM220-02-00A	VM230-02-00A	VM220U-02-00A	VM230U-02-00A	—	—
	Roller lever	Polycetal roller	VM220-02-01A	VM230-02-01A	VM220U-02-01A	VM230U-02-01A	VM-01A	50 g
		Hard steel roller	VM220-02-01SA	VM230-02-01SA	VM220U-02-01SA	VM230U-02-01SA	VM-01AS	60 g
	One way roller lever	Polycetal roller	VM220-02-02A	VM230-02-02A	VM220U-02-02A	VM230U-02-02A	VM-02A	60 g
		Hard steel roller	VM220-02-02SA	VM230-02-02SA	VM220U-02-02SA	VM230U-02-02SA	VM-02AS	70 g
	Straight plunger		VM220-02-05A	VM230-02-05A	VM220U-02-05A	VM230U-02-05A	VM-05A	130 g
	Roller plunger	Polycetal roller	VM220-02-06A	VM230-02-06A	VM220U-02-06A	VM230U-02-06A	VM-06A	120 g
		Hard steel roller	VM220-02-06SA	VM230-02-06SA	VM220U-02-06SA	VM230U-02-06SA	VM-06AS	130 g
	Cross roller plunger	Polycetal roller	VM220-02-07A	VM230-02-07A	VM220U-02-07A	VM230U-02-07A	VM-07A	120 g
		Hard steel roller	VM220-02-07SA	VM230-02-07SA	VM220U-02-07SA	VM230U-02-07SA	VM-07AS	130 g
Manual operation	Toggle lever		VM220-02-08A	VM230-02-08A	VM220U-02-08A	VM230U-02-08A	VM-08A	110 g
	Push button (Mushroom)	Red	VM220-02-30RA	VM230-02-30RA	VM220U-02-30RA	VM230U-02-30RA	VM-30AR	58 g
		Black	VM220-02-30BA	VM230-02-30BA	VM220U-02-30BA	VM230U-02-30BA	VM-30AB	
		Green	VM220-02-30GA	VM230-02-30GA	VM220U-02-30GA	VM230U-02-30GA	VM-30AG	
		Yellow	VM220-02-30YA	VM230-02-30YA	VM220U-02-30YA	VM230U-02-30YA	VM-30AY	
	Push button (Extended)	Red	VM220-02-32RA	VM230-02-32RA	VM220U-02-32RA	VM230U-02-32RA	VM-32AR	52 g
		Black	VM220-02-32BA	VM230-02-32BA	VM220U-02-32BA	VM230U-02-32BA	VM-32AB	
		Green	VM220-02-32GA	VM230-02-32GA	VM220U-02-32GA	VM230U-02-32GA	VM-32AG	
		Yellow	VM220-02-32YA	VM230-02-32YA	VM220U-02-32YA	VM230U-02-32YA	VM-32AY	
	Push button (Flush)	With a set of red, black, green, yellow	VM220-02-33A	VM230-02-33A	VM220U-02-33A	VM230U-02-33A	VM-33A	50 g
Twist selector (2 position)	Red	VM220-02-34RA	VM230-02-34RA	VM220U-02-34RA	VM230U-02-34RA	VM-34AR	56 g	
	Black	VM220-02-34BA	VM230-02-34BA	VM220U-02-34BA	VM230U-02-34BA	VM-34AB		
	Green	VM220-02-34GA	VM230-02-34GA	VM220U-02-34GA	VM230U-02-34GA	VM-34AG		
	Yellow	VM220-02-34YA	VM230-02-34YA	VM220U-02-34YA	VM230U-02-34YA	VM-34AY		
Key selector (2 position)		VM220-02-36A	VM230-02-36A	VM220U-02-36A	VM230U-02-36A	VM-36A	78 g	
Twist selector (3 position)	3 port		5 port		3 port		5 port	
	Red	VM230-02-35RA	VM250-02-35RA	VM230U-02-35RA	VM250U-02-35RA	—	230 g (Add to 2 basic units.)	
	Black	VM230-02-35BA	VM250-02-35BA	VM230U-02-35BA	VM250U-02-35BA			
	Green	VM230-02-35GA	VM250-02-35GA	VM230U-02-35GA	VM250U-02-35GA			
Yellow	VM230-02-35YA	VM250-02-35YA	VM230U-02-35YA	VM250U-02-35YA				
Foot pedal	2 port		3 port		—		—	
	VM220-02-40A	VM230-02-40A	—	—	—	—	340 g	

Note 1) It is possible to change the actuator assembly and mount to basic type when an actuator part number is specified in the column.

Note 2) For push button (mushroom), push button (flush), push button (extended) and individual fastening ring, refer to page 1612.

Note 3) The handle of the selector (2 position and 3 position) cannot be removed or replaced alone.

Note 4) Color of plunger: Gray (2 port), White (3 port)

How to Order

VM2 3 0 - 02 - 01 S A - B -

Number of ports

2	2 port
3	3 port
5	5 port (Twist selector 3 position only)

Body option

Nil	Side mounting
U	With bottom mounting thread

Port size

02	R1/4
N02	NPT1/4
F02	G1/4

Actuator type*

00	Basic
01	Roller lever
02	One way roller lever
05	Straight plunger
06	Roller plunger
07	Cross roller plunger
08	Toggle lever
30	Push button (Mushroom)
32	Push button (Flush)
33	Push button (Extended)
34	Twist selector (2 position)
36	Key selector (2 position)
35	Twist selector (3 position)
40	Foot pedal

Made to Order (Pages 1608, 1609)

X207	Alternate type, Mushroom push button
X219	Push-lock turn-reset type, Mushroom push button

(Note) Applicable only to push button (mushroom)

Bracket option

Nil	None
B	With bracket

(Note) Applicable only to side mounting type.
However, not applicable to twist selector (3 position) and foot pedal.
Bracket is shipped together, but not assembled.

Suffix for actuator*

S	Hard steel roller	
R	Red	Color of push button, selector
B	Black	
G	Green	
Y	Yellow	

* Refer to the table on page 1600 for combinations of actuator type and suffix.

Construction

Non-actuated

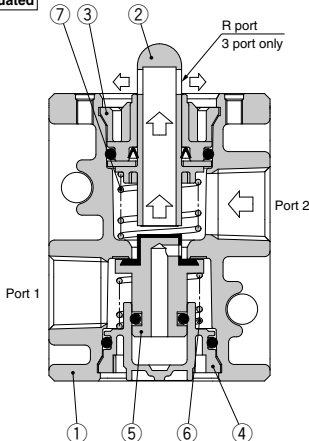

Actuated

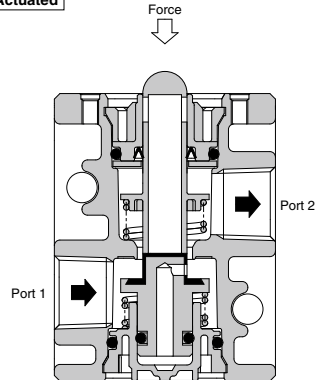

VM

VMG

VR

VR51

VHK

VH

VHS

VHS

Component Parts

No.	Description	Material	Note
1	Valve	ADC	White coated
2	Plunger	Polyacetal	2 port Gray
			3 port White
3	Plunger retainer	PBT	
4	Cover	PBT	
5	Inner valve	NBR, Brass	
6	Spring	Stainless steel	
7	Spring	Spring steel	

VM200 Series

VM200 Series

Basic
VM220-02-00A
VM230-02-00A

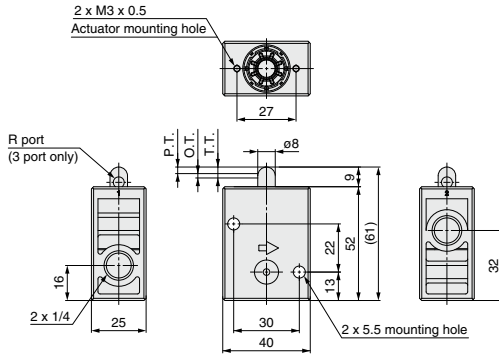

Symbol

2 port

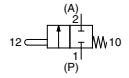

3 port

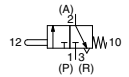

* 0.5 MPa supply

F.O.F. ^①	52 N
P.T.	3 mm
O.T.	2 mm
T.T.	5 mm

Roller lever
VM220-02-01A
VM230-02-01A
VM220-02-01SA
VM230-02-01SA

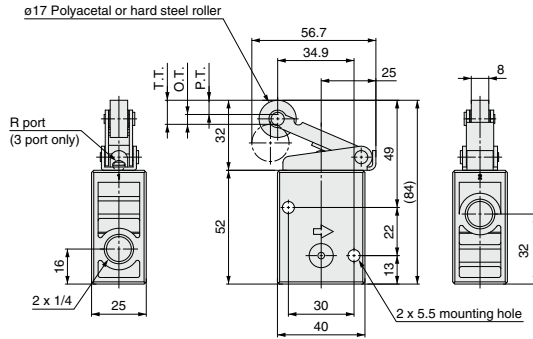

Symbol

2 port

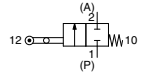

3 port

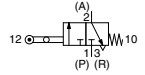

* 0.5 MPa supply

F.O.F. ^①	24 N
P.T.	6.5 mm
O.T.	4.5 mm
T.T.	11 mm

One way roller lever
VM220-02-02A
VM230-02-02A
VM220-02-02SA
VM230-02-02SA

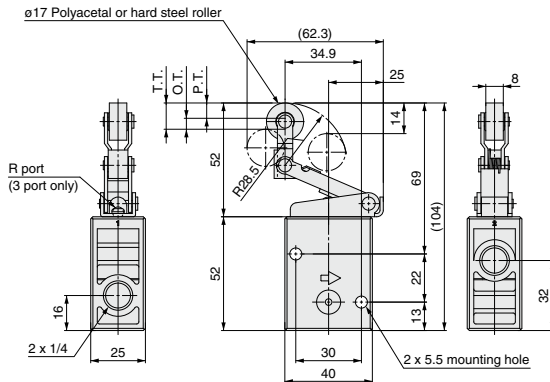

Symbol

2 port

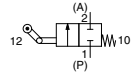

3 port

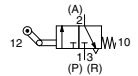

* 0.5 MPa supply

F.O.F. ^①	22 N
P.T.	7 mm
O.T.	5 mm
T.T.	12 mm

VM200 Series

Straight plunger
VM220-02-05A
VM230-02-05A

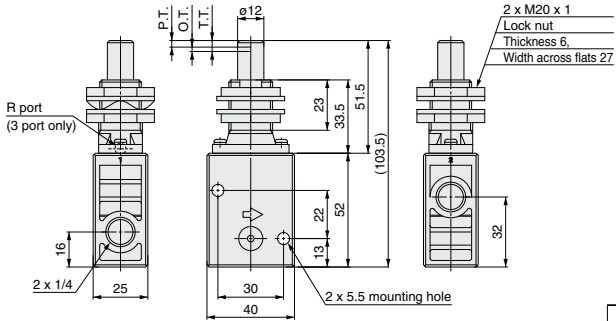

Panel mounting hole

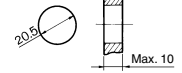

Symbol
 2 port

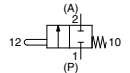

3 port

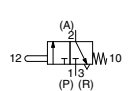

* 0.5 MPa supply

F.O.F. [※]	56 N
P.T.	3.5 mm
O.T.	2 mm
T.T.	5.5 mm

Roller plunger
VM220-02-06A
VM230-02-06A
VM220-02-06SA
VM230-02-06SA

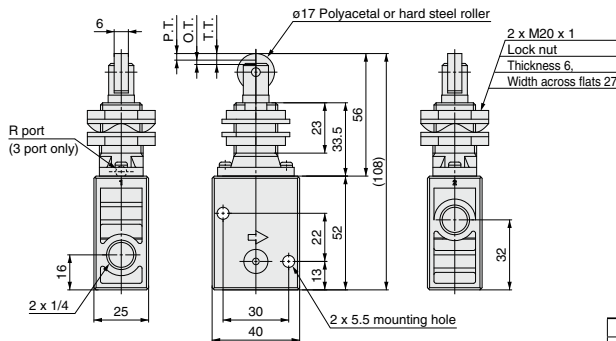

Panel mounting hole

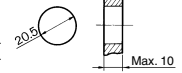

Symbol
 2 port

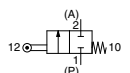

3 port

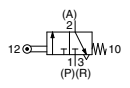

* 0.5 MPa supply

F.O.F. [※]	56 N
P.T.	3.5 mm
O.T.	2 mm
T.T.	5.5 mm

Cross roller plunger
VM220-02-07A
VM230-02-07A
VM220-02-07SA
VM230-02-07SA

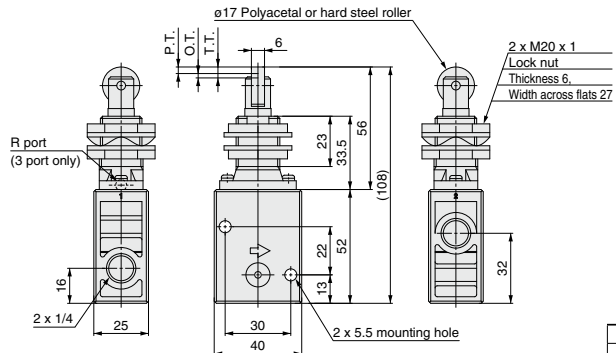

Panel mounting hole

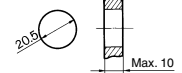

Symbol
 2 port

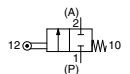

3 port

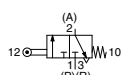

* 0.5 MPa supply

F.O.F. [※]	56 N
P.T.	3.5 mm
O.T.	2 mm
T.T.	5.5 mm

- VM**
- VMG**
- VR**
- VR51**
- VHK**
- VH**
- VHS**
- VHS**

VM200 Series

VM200 Series

Toggle lever
VM220-02-08A
VM230-02-08A

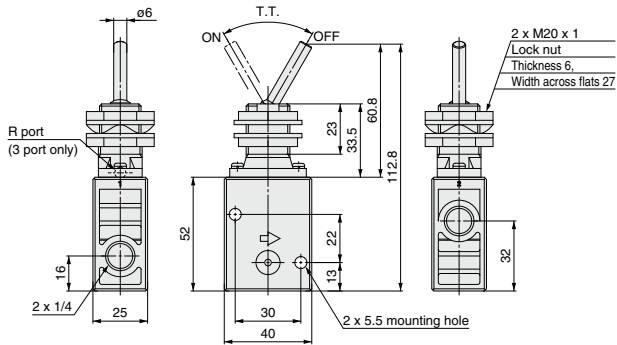

Panel mounting hole

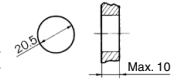

Symbol

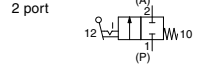

3 port

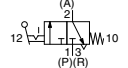

* 0.5 MPa supply

F.O.F.*	12 N
T.T.	60°

Push button (Mushroom)
VM220-02-30 (R, B, G, Y) A
VM230-02-30 (R, B, G, Y) A

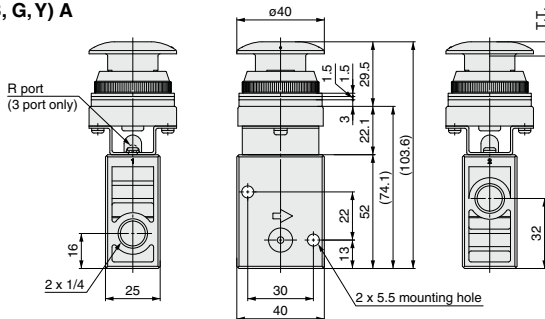

Panel mounting hole

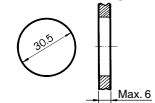

Symbol

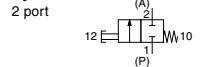

3 port

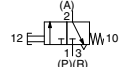

* 0.5 MPa supply

F.O.F.*	52 N
T.T.	6.5 mm

Push button (Extended)
VM220-02-32 (R, B, G, Y) A
VM230-02-32 (R, B, G, Y) A

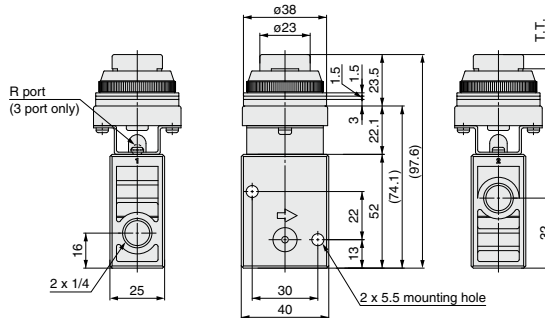

Panel mounting hole

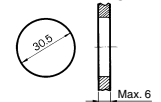

Symbol



3 port

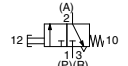

* 0.5 MPa supply

F.O.F.*	52 N
T.T.	6.5 mm

VM200 Series

Push button (Flush)

VM220-02-33A

VM230-02-33A

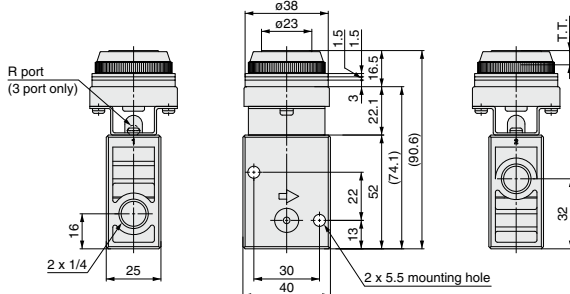

Panel mounting hole

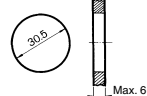

Symbol

2 port

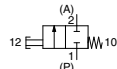

3 port

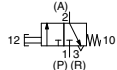

* 0.5 MPa supply

F.O.F.*	52 N
T.T.	6.5 mm

Twist selector (2 position)

VM220-02-34 (R, B, G, Y) A

VM230-02-34 (R, B, G, Y) A

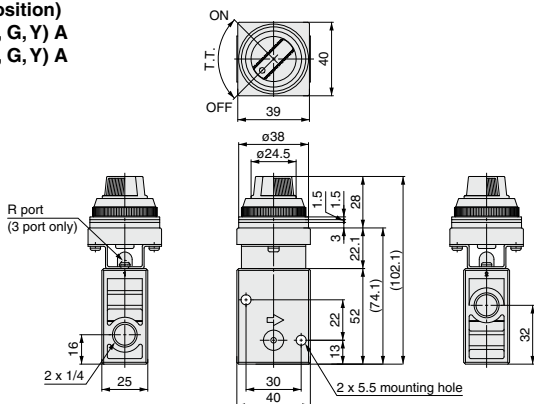

Panel mounting hole

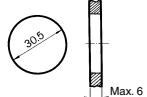

Symbol

2 port

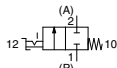

3 port

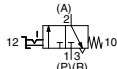

* 0.5 MPa supply

F.O.F.*	32 N
T.T.	90°

Key selector (2 position)

VM220-02-36A

VM230-02-36A

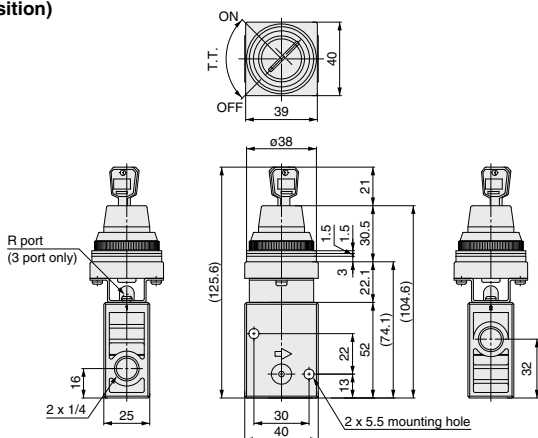

Panel mounting hole

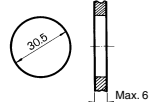

Symbol

2 port

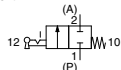

3 port

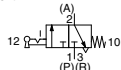

* 0.5 MPa supply

F.O.F.*	32 N
T.T.	90°

Key can be removed at the "on" and "off" positions.
One spare key is included.

- VM
- VMG
- VR
- VR51
- VHK
- VH
- VHS
- VHS

VM200 Series

VM200 Series

Twist selector (3 position)
 VM230-02-35 (R, B, G, Y) A
 VM250-02-35 (R, B, G, Y) A

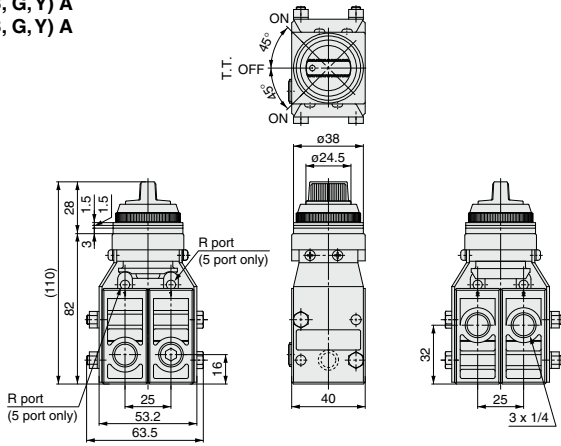

Panel mounting hole

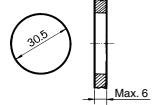

Symbol

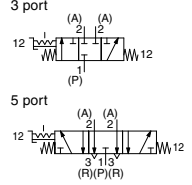

* 0.5 MPa supply

F.O.F. [®]	40 N
T.T.	45°

Foot pedal
 VM220-02-40A
 VM230-02-40A

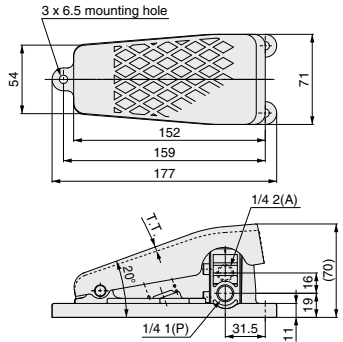

Symbol

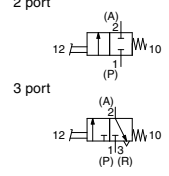

* 0.5 MPa supply

F.O.F. [®]	65 N
T.T.	1.2°

VM200 Series

With bracket

VM220-02-□A-B
VM230-02-□A-B

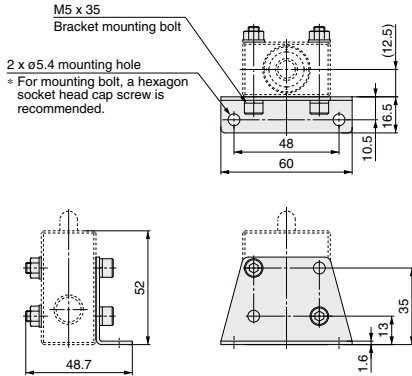

VM2-B

Component parts	Q'ty
Bracket	1
Hexagon socket head cap screw M5 x 35	2
Hexagon nut M5	2

With bottom mounting thread

VM220U-02-□A
VM230U-02-□A

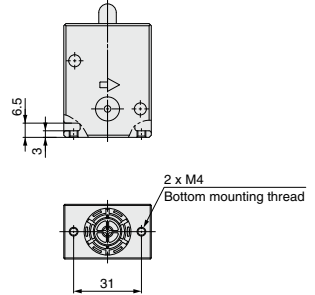

VM230U-02-35□A
VM250U-02-35□A

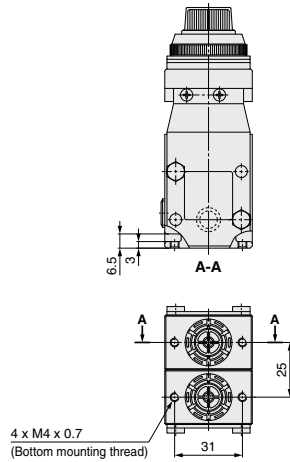

- VM**
- VMG**
- VR**
- VR51**
- VHK**
- VH**
- VHS□**
- VHS**

VM100/200 Series Made to Order

Please contact SMC for detailed specifications, dimensions and lead times.



1 Alternate type, Mushroom push button

Symbol
-X207

Alternate type: When pressing the push button, the valve actuates and its status is self-retained even after your hand has been released. Pressing the button again will restore the valve to its previous status.

VM120-01-30 (R, B, G, Y) A-X207

VM130-01-30 (R, B, G, Y) A-X207

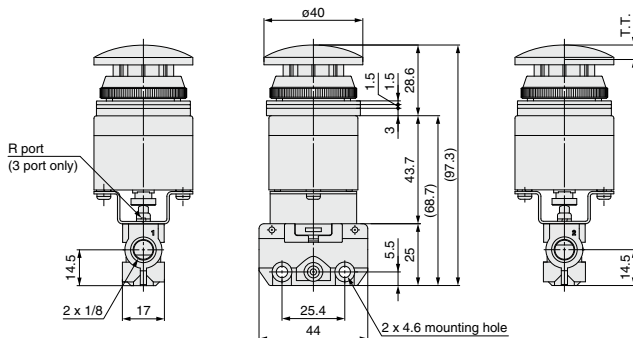

Panel mounting hole

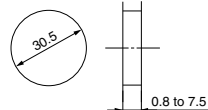

Symbol

2 port

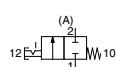

3 port

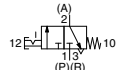

* 0.5 MPa supply

F.O.F. ²⁾	27 N
T.T.	6.7 mm

VM220-02-30 (R, B, G, Y) A-X207

VM230-02-30 (R, B, G, Y) A-X207

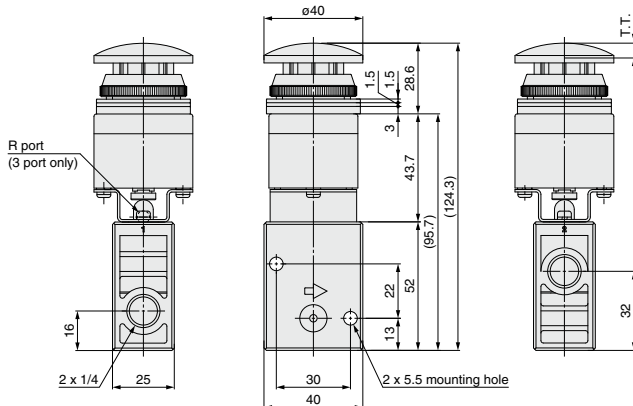

Panel mounting hole

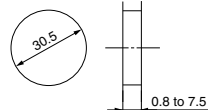

Symbol

2 port

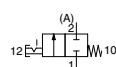

3 port

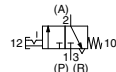

* 0.5 MPa supply

F.O.F. ²⁾	52 N
T.T.	6.7 mm

2 Push-lock turn-reset type, Mushroom push button

Symbol
-X219

Push-lock turn-reset type: When pressing the push button, it is locked in this status. Turning the button clockwise will reset it.

VM120-01-30 (R, B, G, Y) A-X219

VM130-01-30 (R, B, G, Y) A-X219

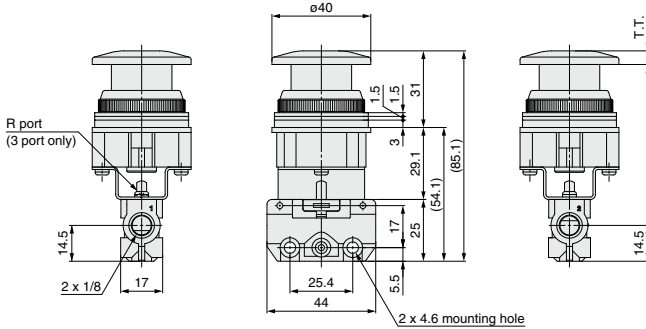

Panel mounting hole

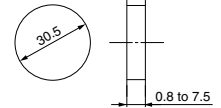

Symbol
2 port

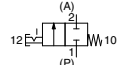

3 port

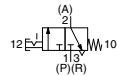

* 0.5 MPa supply

F.O.F. ^④	27 N
T.T.	5.8 mm

VM220-02-30 (R, B, G, Y) A-X219

VM230-02-30 (R, B, G, Y) A-X219

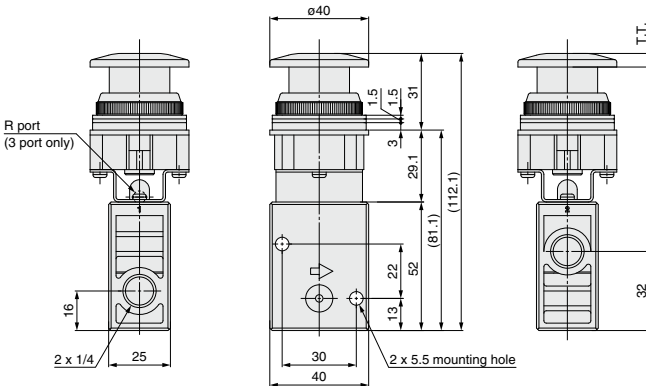

Panel mounting hole

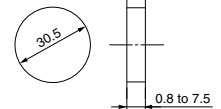

Symbol
2 port

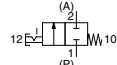

3 port

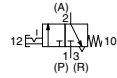

* 0.5 MPa supply

F.O.F. ^④	52 N
T.T.	5.8 mm

- VM**
- VMG**
- VR**
- VR51**
- VHK**
- VH**
- VHS**
- VHS**



VM100/200 Series Specific Product Precautions 1

Be sure to read this before handling the products.

Refer to back page 50 for Safety Instructions and pages 3 to 9 for 3/4/5 Port Solenoid Valve Precautions.

Definition of Symbol

The abbreviations F.O.F. / P.T. / O.T. / T.T. shown in this catalog are detailed below.

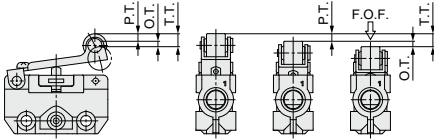

- **F.O.F. <Full Operating Force>**
Required force to total travel position
- **P.T. <Pre-travel>**
From free position to initial valve operating position
- **O.T. <Over Travel>**
From initial valve operating position to total travel position
- **T.T. <Total Travel>**
From free position to total travel position

Design

⚠ Warning

1. **This product cannot be used for applications in which the pressure must be sealed.**

Since the VM100 and VM200 are poppet type valves, fluid flows backward when the pressure on port 2 (A) rises.

Since the valves are subject to air leakage, they cannot be used for applications such as holding pressure (including vacuum).

2. **Not suitable for use as an emergency shutoff valve**

This mechanical valve is not designed for safety applications such as an emergency shutoff valve. If the valves are used for the mentioned applications, additional safety measures should be adopted.

Mounting

⚠ Warning

1. **When installing the mechanical operation type mechanical valves, adjust the position so that the valves do not operate over the operating limit range.**

Operating over the limit could damage the mechanical valve or actuator, and lead to equipment malfunction.

Mounting

⚠ Warning

2. **P.T. depends on pressure or differences between the individual product specifications. In order to ensure that the valve opens, keep the operating stroke value for the mechanical operation type within the range specified by the following formula.**

Operating stroke = (P.T. + 0.5 x O.T.) to (P.T. + O.T. - 0.1)

Operating Stroke Range

Series	Actuator type	Operating stroke (mm)
VM100	Basic	2.2 to 2.9
	Roller lever	4.3 to 5.4
	One way roller lever	4.3 to 5.4
	Straight plunger	2.7 to 3.4
	Roller plunger	2.7 to 3.4
	Cross roller plunger	2.7 to 3.4
VM200	Basic	4 to 4.9
	Roller lever	8.7 to 10.9
	One way roller lever	9.5 to 11.9
	Straight plunger	4.5 to 5.4
	Roller plunger	4.5 to 5.4
	Cross roller plunger	4.5 to 5.4

For straight and roller plunger types, there is a groove indicating P.T. and T.T. for stroke adjustment.

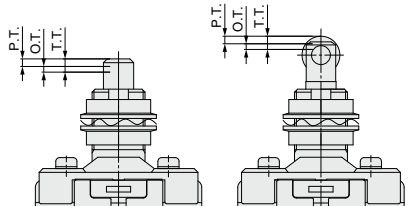

3. **Do not make any alterations to the valve body, such as enlarging the body mounting holes.**

As doing so could lead to unexpected abnormal conditions such as air leakage.

Operation

⚠ Warning

1. **Operate the manual operation type mechanical valves (such as push button, twist selector and toggle lever types) with your finger.**

The use of equipment such as a cylinder, cam or hammer, can result in the actuator and the valve being damaged.

Do not operate over the operation limit. If excessive operation force is applied over total travel position, actuator part can get deformed and lead to equipment malfunction.



VM100/200 Series Specific Product Precautions 2

Be sure to read this before handling the products.

Refer to back page 50 for Safety Instructions and pages 3 to 9 for 3/4/5 Port Solenoid Valve Precautions.

Operation

⚠ Warning

2. When operating the mechanical operation type mechanical valves, select the angle and the maximum speed limit of cam and dog so that valves do not operate over the following maximum values.

If operated over the maximum values, impact force from cam and dog will be applied to the actuator, leading to damage of the actuator or the valve itself.

Cam and Dog

Series	Actuator type	Angle limit of cam and dog	Max. speed limit of cam and dog (m/s)
VM100	Roller lever	30°	0.7
		45°	0.3
	One way roller lever	30°	0.7
		45°	0.3
	Straight plunger	—	0.2
	Roller plunger	30°	0.3
Cross roller plunger	30°	0.3	
VM200	Roller lever	30°	0.7
		45°	0.3
	One way roller lever	30°	0.7
		45°	0.3
	Straight plunger	—	0.2
	Roller plunger	30°	0.3
Cross roller plunger	30°	0.3	

[Not acceptable]

Over 45° (Abrupt angle)

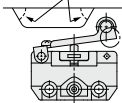

[Acceptable]

45° or less

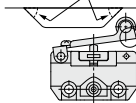

[Not acceptable]

Max. travel

Over travel. Excessive force is applied due to the maximum travel position being exceeded.

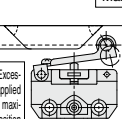

[Acceptable]

Max. travel

Sufficient travel. The actuator can reach the total travel position without excessive force being applied.

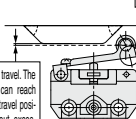

Cam and Dog Material

Roller material	Cam and dog material	Surface finish of cam and dog
Polyacetal	Steel	6.3 z or less
Hard steel	Steel, Resin	25 z or less

3. Operate the roller lever type from the direction shown below.

In cases where the dog goes over the actuator, select the one way roller lever type or the roller plunger type.

[Not acceptable]

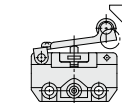

[Acceptable]

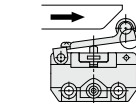

Operation

⚠ Caution

1. If the operating condition is maintained for long periods of time, it may take some time for the valve to restart due to the adherence of the seals and there might be a delay for recovery.

Air Supply

⚠ Warning

1. Operable fluid is either air or inert gas only.
It cannot be used for corrosive gas and fluid.

⚠ Caution

1. Grease is used for the inside of the valves.

Grease may enter into the outlet port of the valve.

2. When using vacuum pressure for the VM100, supply vacuum pressure to P port.

Operating Environment

⚠ Warning

1. Do not operate it in an area in which fluids such as oil, coolant, or water splash on it or dust comes in contact with it.

Because it does not have a waterproof or dustproof construction, fluids or dust could enter the valve, leading to malfunction. Therefore, take measures such as providing a protective cover to prevent direct exposure.

2. Do not expose the product to direct sunlight for an extended period of time.

Maintenance

⚠ Warning

1. Perform inspections on a regular basis as necessary, such as at the beginning of an operation, to make sure that the mechanical valve operates properly.

2. Do not disassemble, modify or repair the product.

This may lead to malfunction of equipment, injury and equipment damage. Please contact SMC for repairs and maintenance of the product.

VM
VMG
VR
VR51
VHK
VH
VHS □
VHS



VM100/200 Series Specific Product Precautions 3

Be sure to read this before handling the products.

Refer to back page 50 for Safety Instructions and pages 3 to 9 for 3/4/5 Port Solenoid Valve Precautions.

How to Change the Buttons

Caution

Replace the button in the following manner to change color of the button.

1. Push button (Flush type)

- Installation — Of the four colors, red, green, black, and yellow, select and align the protruding portion of the button with the recessed portion of the body and push in.
- Removal — Remove the fastening ring and insert the tip of a small flat head screwdriver into the groove of the button to pry it up.

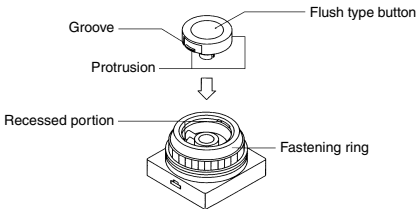

2. Push button (Mushroom and Extended types)

At the time of shipment, only 1 button of the color that you specified is attached to the body.

	Mushroom type	Extended type
Installation	Align the protruding portion of the button with the recessed portion of the body and push in. (Use the mark on the button as a reference to align the protruding part.)	Align the protruding portion of the button with the recessed portion of the body and push in.
Removal	Placing your finger under the collar of the button on the side of the mark, tilt it upward.	Remove the fastening ring and insert the tip of a small flat head screwdriver into the groove of the button to pry it up.

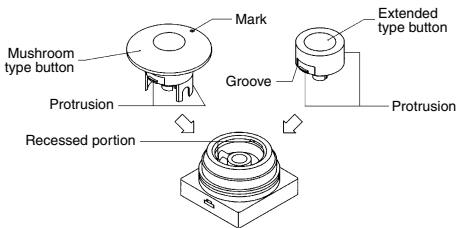

How to remove a mushroom type button

How to remove at panel mount

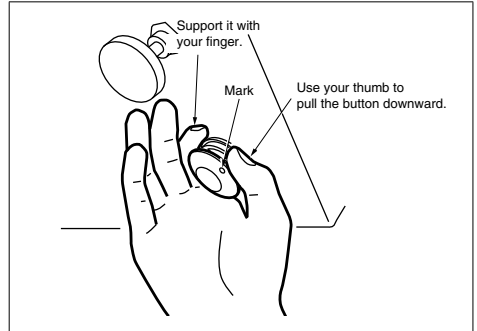

Removing the valve as a unit

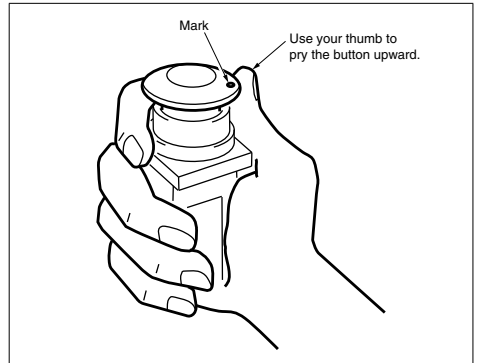

Replacement Parts

1. Use the part numbers listed below to order individual mushroom, extended, or flush type buttons.

Color	Mushroom type button	Extended type button
Red	3402186R	3402187R
Black	3402186B	3402187B
Green	3402186G	3402187G
Yellow	3402186Y	3402187Y

Color	Flush type button
Red	3402188R
Black	3402188B
Green	3402188G
Yellow	3402188Y

2. Use the part number below to order individual fastening ring.
Fastening ring: 3402184



VM100/200 Series Specific Product Precautions 4

Be sure to read this before handling the products.

Refer to back page 50 for Safety Instructions and pages 3 to 9 for 3/4/5 Port Solenoid Valve Precautions.

VM-X219 Series How to Mount Panel

[Task 1] Removing the push button and fastening ring

Remove them from the body turning them counterclockwise in the order of the push button and fastening ring.

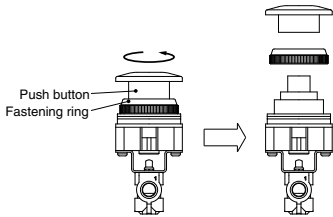

[Task 2] Mounting the valve to the panel

Insert the valve to the panel and fix it with a fastening ring. Remove three spacers attached to the valve depending on the panel thickness.

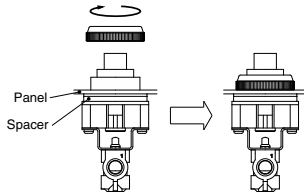

[Task 3] Mounting the push button

Tighten the push button clockwise by hand and further tighten it until load is applied.

Note) When the push button is not tightened enough, the valve may not output correctly after operating the push button. In other cases, the valve outputs temporarily, but when it is in the holding state, the valve may stop outputting. In this situation, tighten the push button again.

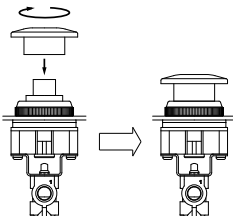

VM
VMG
VR
VR51
VHK
VH
VHS□
VHS

3 Port Mechanical Valve

VM400 Series



Either N.C. or N.O. is available.

Piping possible to any port.

Proper countermeasures can be taken for applications in which the noise of the exhaust could cause problems to the surroundings.



Specifications

Fluid	Air			
Operating pressure	-100 kPa to 1.0 MPa			
Ambient and fluid temperature	-5 to 60°C (No freezing)			
Flow rate characteristics	C[dm ³ /(s·bar)]	b	Cv	
	1(NC)↔2(OUT)	1.4	0.2	0.29
	2(NO)↔3(OUT)	1.4	0.15	0.29
Lubrication	Not required (Use turbine oil Class 1 ISO VG32, if lubricated)			
Port size	1/8			

Model

	Actuator	Model	Actuator part no.	Application	Weight (g)
Mechanical operation	Basic	VM430-01-00	—	—	110
		VM430-01-01	VM-01A	Polyacetal roller	140
	Roller lever	VM430-01-01S	VM-01AS	Hard steel roller	150
		VM430-01-02	VM-02A	Polyacetal roller	150
	One way roller lever	VM430-01-02S	VM-02AS	Hard steel roller	160
		VM430-01-05	VM-05A	—	220
	Straight plunger	VM430-01-06	VM-06A	Polyacetal roller	210
		VM430-01-06S	VM-06AS	Hard steel roller	220
Roller plunger	VM430-01-07	VM-07A	Polyacetal roller	210	
	VM430-01-07S	VM-07AS	Hard steel roller	220	
Cross roller plunger	VM430-01-08	VM-08A	—	200	
	VM430-01-30R	VM-30AR	Red	168	
Push button (Mushroom)	VM430-01-30B	VM-30AB	Black		
	VM430-01-30G	VM-30AG	Green		
	VM430-01-30Y	VM-30AY	Yellow		
Push button (Extended)	VM430-01-32R	VM-32AR	Red	162	
	VM430-01-32B	VM-32AB	Black		
	VM430-01-32G	VM-32AG	Green		
	VM430-01-32Y	VM-32AY	Yellow		
Push button (Flush)	VM430-01-33	VM-33A	With a set of red, black, green, yellow	167	
Twist selector (2 position)	VM430-01-34R	VM-34AR	Red	168	
	VM430-01-34B	VM-34AB	Black		
	VM430-01-34G	VM-34AG	Green		
	VM430-01-34Y	VM-34AY	Yellow		
Key selector (2 position)	VM430-01-36	VM-36A	—	188	

Note 1) Actuator replacement is available for all types.

Note 2) For push button (mushroom), push button (extended), push button (flush) and a single unit of fastening ring, refer to pages 1655 and 1656. The other parts are not replaceable.

Note 3) The handle of the selector (2 position) cannot be removed or replaced alone.

How to Order

VM4 3 0 - 01 - 01 S -

● **Number of ports**

3	3 port
---	--------

● **Port size**

01	Rc 1/8
N01	NPT 1/8
F01	G 1/8

● **Made to Order**
(Refer to pages 1648 to 1651 for details.)

X207	Alternate type, Mushroom push button
X219	Push-lock turn-reset type, Mushroom push button

● **Actuator type***

00	Basic
01	Roller lever
02	One way roller lever
05	Straight plunger
06	Roller plunger
07	Cross roller plunger
08	Toggle lever
30	Push button (Mushroom)
32	Push button (Extended)
33	Push button (Flush) <small>Note 1)</small>
34	Twist selector (2 position)
36	Key selector (2 position)

● **Suffix for actuator***

S	Hard steel roller	
R	Red	Color of push button selector
B	Black	
G	Green	
Y	Yellow	

* Refer to the table on page 1614 for combinations of actuator type and suffix.

Note 1) When selecting the flush type, it is not necessary to select the suffix for the actuator.

Construction

Non-actuated

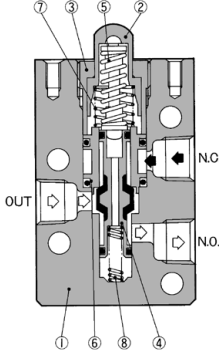

Actuated

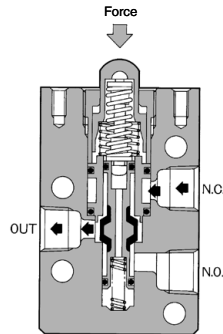

Component Parts

No.	Description	Material	Note
1	Body	ADC	Platinum silver
2	Plunger	POM	
3	Upper lid	Brass	Black zinc chromated
4	Spool valve	Aluminum alloy, NBR	Rubber lined

No.	Description	Material	Note
5	Over travel spring	Stainless steel	
6	Retainer	Brass	
7	Spring	Stainless steel	
8	Spring	Stainless steel	

VM
VMG
VR
VR51
VHK
VH
VHS □
VHS

VM400 Series

VM400 Series

Basic VM430-01-00

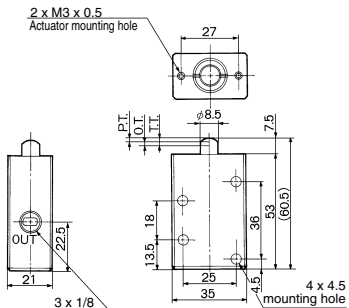

Symbol

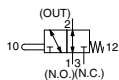

F.O.F.	26 N
P.T.	1.5 mm
O.T.	2.0 mm
T.T.	3.5 mm

Roller lever VM430-01-01 VM430-01-01S

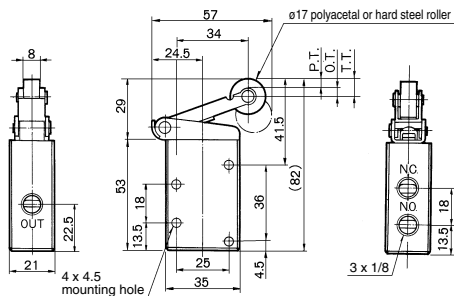

Symbol

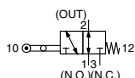

F.O.F.	12 N
P.T.	4.0 mm
O.T.	4.5 mm
T.T.	8.5 mm

One way roller lever VM430-01-02 VM430-01-02S

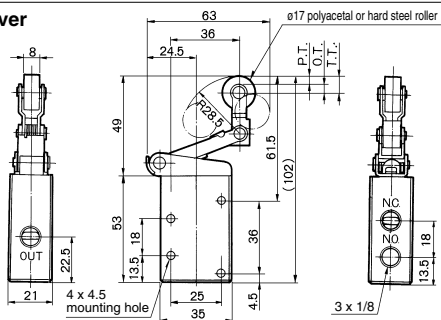

Symbol

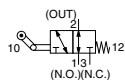

F.O.F.	11 N
P.T.	4.0 mm
O.T.	5.0 mm
T.T.	9.0 mm

Straight plunger VM430-01-05

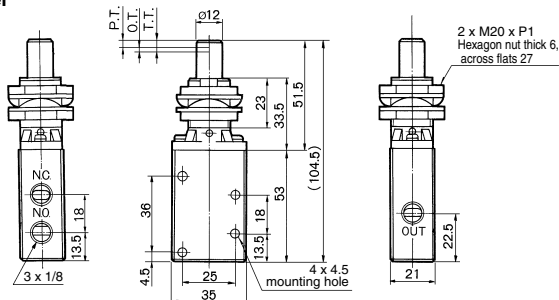

Panel mounting hole

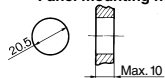

Symbol

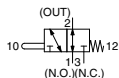

F.O.F.	30 N
P.T.	3.5 mm
O.T.	2.0 mm
T.T.	5.5 mm

VM400 Series

VM400 Series

Push button (Extended) VM430-01-32R/B/G/Y

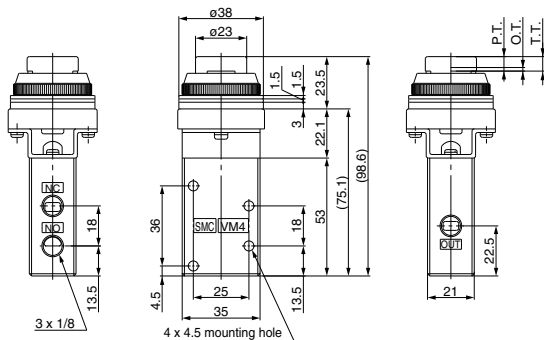

Panel mounting hole

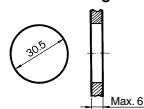

Symbol

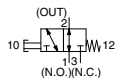

F.O.F.	26 N
P.T.	5.4 mm
O.T.	1.6 mm
T.T.	6.5 mm

Push button (Flush) VM430-01-33

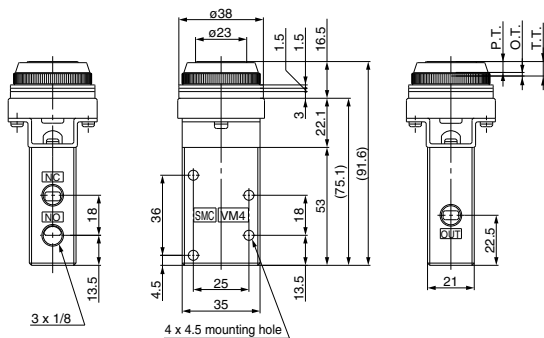

Panel mounting hole

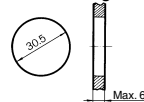

Symbol

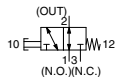

F.O.F.	26 N
P.T.	4.9 mm
O.T.	1.6 mm
T.T.	6.5 mm

Twist selector (2 position) VM430-01-34R/B/G/Y

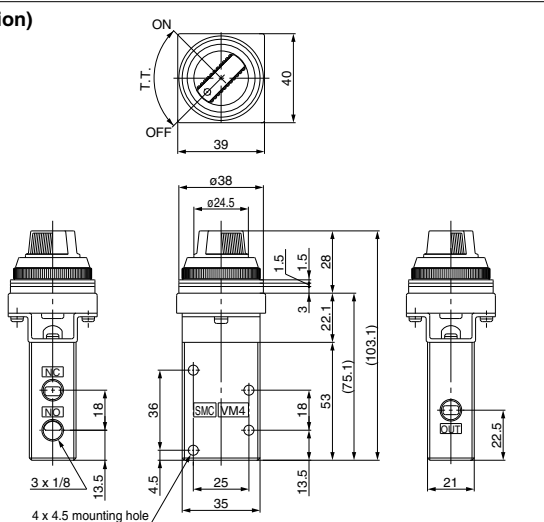

Panel mounting hole

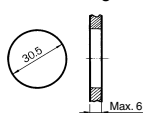

Symbol

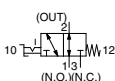

F.O.F.	20 N
T.T.	90°

VM400 Series

Key selector (2 position) VM430-01-36

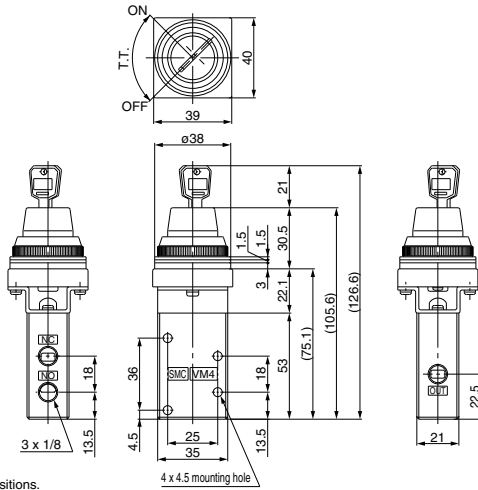

Key can be removed at the "on" and "off" positions.

Panel mounting hole

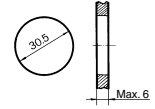

Symbol

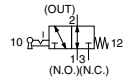

F.O.F.	20 N
T.T.	90°

VM

VMG

VR

VR51

VHK

VH

VHS

VHS

3 Port Mechanical Valve: Heavy Duty Type

VM800 Series

RoHS

Sturdy construction.

Either N.C. or N.O. is available.

Piping possible to any port.

Proper countermeasures can be taken for applications in which the noise of the exhaust could cause problems to the surroundings.

Many actuator positions and orientation options.



Specifications

Fluid	Air		
Operating pressure	-100 kPa to 1.0 MPa		
Ambient and fluid temperature	-5 to 60°C (No freezing)		
Flow rate characteristics	C [dm ³ /(s·bar)]	b	Cv
	1 (NC) ↔ 2 (OUT)	1.4	0.2 0.29
	2 (NO) ↔ 3 (OUT)	1.4	0.15 0.29
Lubrication	Not required (Use turbine oil Class 1 ISO VG32, if lubricated.)		
Port size	1/8		

Model

Actuator	Model	Actuator part no.	Weight (g)
Basic	VM830-01-00	—	180
Roller lever	VM830-01-01	VM-01F	280
Adjustable roller lever	VM830-01-13	VM-13F	300
Adjustable rod lever	VM830-01-14	VM-14F	276

• Actuator replacement is available.

How to Order

VM830 - 01 - 01

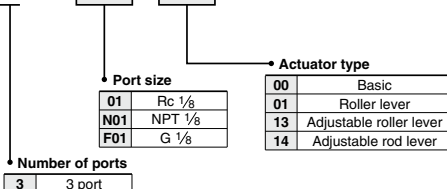

Application

● Movement is changeable.

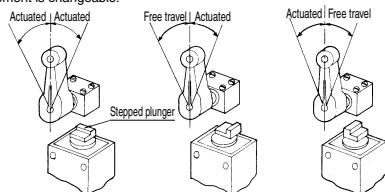

● Roller can be mounted to inside of lever.

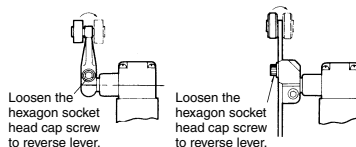

● Lever location can be changed.

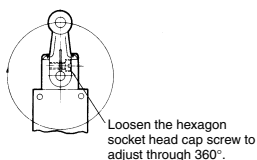

● Head direction can be changed.

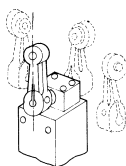

● Lever length adjustment.

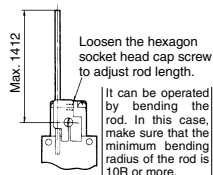
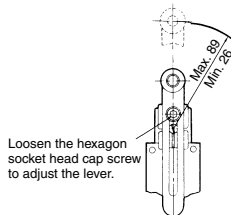

Construction

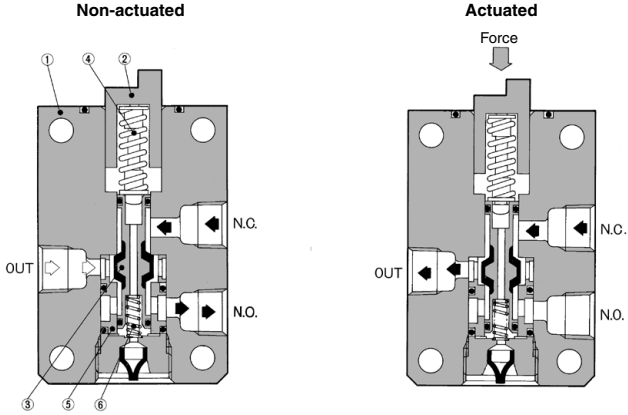

Component Parts

No.	Description	Material	Note
1	Body	ADC	Platinum silver
2	Plunger	POM	
3	Spool valve	Aluminum alloy, NBR	Rubber lined

No.	Description	Material	Note
4	Over travel spring	Stainless steel	
5	Retainer	Brass	
6	Spring	Steel	Zinc chromated

VM800 Series

Basic / VM830-01-00

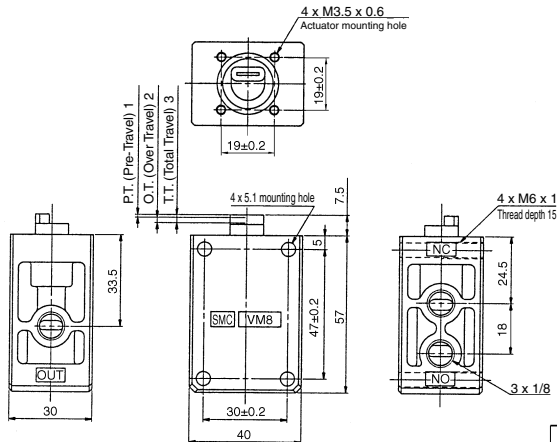

Symbol

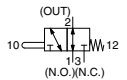

F.O.F.	23 N
P.T.	1.0 mm
O.T.	2.0 mm
T.T.	3.0 mm

VM800 Series

VM800 Series

Roller lever / VM830-01-01

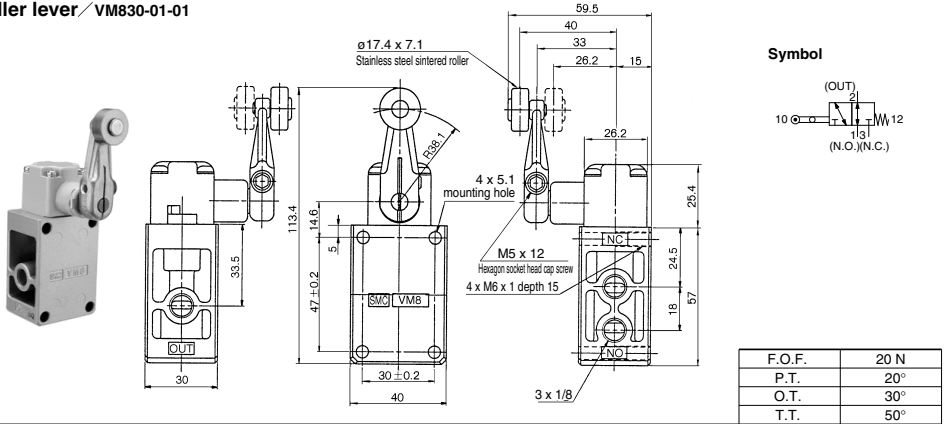

Adjustable roller lever / VM830-01-13

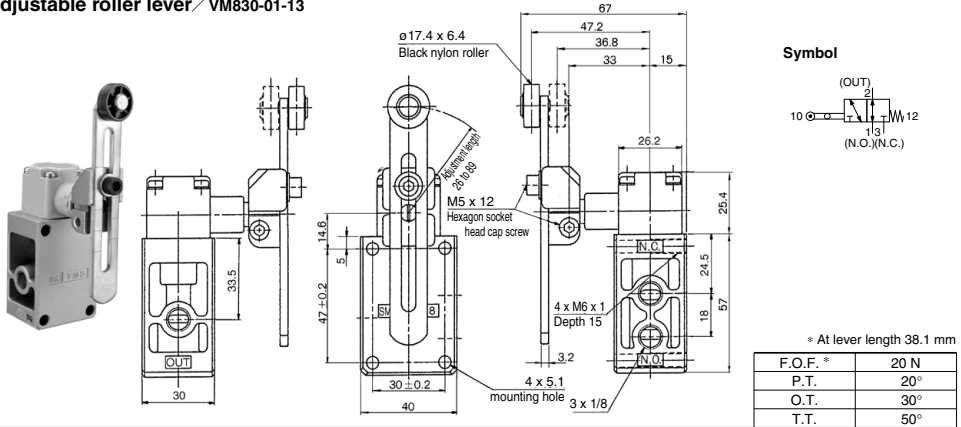

Adjustable rod lever / VM830-01-14

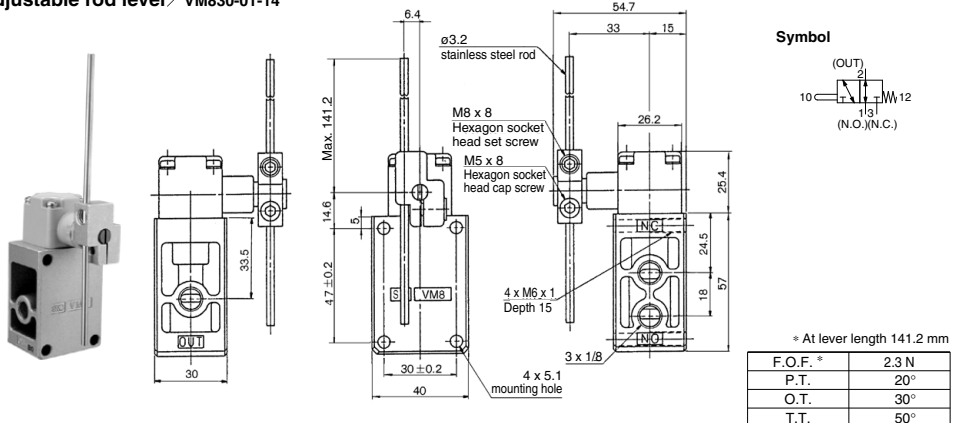

5 Port Mechanical Valve Metal Seal

VZM400 Series



**Compact design,
large flow capacity
High cycle rate,
long life/300 c.p.m. or less
Piping possible to any EXH
port.**

Proper countermeasures can be taken for applications in which the noise of the exhaust could cause problems to the surroundings.

**Pilot type is selectable.
(Internal pilot and external pilot)**



Specifications

Fluid	Air			
Operating pressure	0.15 to 1.0 MPa ⁽¹⁾			
Ambient and fluid temperature	-5 to 60°C (No freezing)			
Flow rate characteristics	C[dm ³ /(s·bar)]	b	Cv	
	1(P)→2(B)/4(A)	2.0	0.14	0.49
	2(B)/4(A)→4(EB)/5(EA)	1.7	0.25	0.44
Maximum frequency (Mechanical operation type)	300 c.p.m. or less			
Lubrication	Not required (Use turbine oil class 1 ISO VG32, if lubricated.)			
Port size	Main valve 1/8			
	Pilot valve (EXH)/M5 x 0.8			
Option	Foot bracket ⁽²⁾			

Note 1) External pilot type Main valve: 0 to 1.0 MPa
Pilot valve: 0.15 to 1.0 MPa

Note 2) The standard body can not be retrofitted with a foot bracket.

Model

	Actuator	Model	Actuator part no.	Application	Weight (g)
Mechanical operation	Basic	VZM450-01-00	—	—	120
	Roller lever	VZM450-01-01	VM-01C	Polyacetal roller	160
		VZM450-01-01S	VM-01CS	Hard steel roller	170
	One way roller lever	VZM450-01-02	VM-02C	Polyacetal roller	170
		VZM450-01-02S	VM-02CS	Hard steel roller	180
	Straight plunger	VZM450-01-05	VM-05C	—	200
Roller plunger	VZM450-01-06	VM-06C	Polyacetal roller	200	
	VZM450-01-06S	VM-06CS	Hard steel roller	200	
Manual operation	Toggle lever	VZM450-01-08	VM-08C	—	190
	Push button (Mushroom)	VZM450-01-30R	VM-30CR	Red	199
		VZM450-01-30B	VM-30CB	Black	
		VZM450-01-30G	VM-30CG	Green	
		VZM450-01-30Y	VM-30CY	Yellow	
	Push button (Extended)	VZM450-01-32R	VM-32CR	Red	192
		VZM450-01-32B	VM-32CB	Black	
		VZM450-01-32G	VM-32CG	Green	
	Push button (Flush)	VZM450-01-32Y	VM-32CY	Yellow	197
		VZM450-01-33	VM-33C	With a set of red, black, green, yellow	
	Twist selector (2 position)	VZM450-01-34R	VM-34CR	Red	198
		VZM450-01-34B	VM-34CB	Black	
		VZM450-01-34G	VM-34CG	Green	
		VZM450-01-34Y	VM-34CY	Yellow	
Key selector (2 position)	VZM450-01-36	VM-36C	—	217	

Note 1) Actuator replacement is available for all types.

Note 2) For push button (mushroom), push button (extended), push button (flush) and a single unit of fastening ring, refer to pages 1855 and 1856. The other parts are not replaceable.

Note 3) The handle of the selector (2 position) cannot be removed or replaced alone.



VZM400 Series

How to Order

VZM45 0 - 01 - 01 S - [] - []

● **Made to Order**
(Refer to pages 1648 to 1651 for details.)

X207	Alternate type, Mushroom push button
X219	Push-lock turn-reset type, Mushroom push button

● **Port size**

01	Rc 1/8
N01	NPT 1/8
F01	G 1/8

● **Body option**

0	Internal pilot type
1	External pilot type

● **Actuator type***

00	Basic
01	Roller lever
02	One Way Roller Lever
05	Straight plunger
06	Roller plunger
08	Toggle lever
30	Push button (Mushroom)
32	Push button (Extended)
33	Push button (Flush) <small>Note 1)</small>
34	Twist selector (2 position)
36	Key selector (2 position)

S	Hard steel roller	Color of push button selector
R	Red	
B	Black	
G	Green	
Y	Yellow	

* Refer to the table on page 1623 for combinations of actuator type and suffix.

● **Option**

F	Foot bracket (Only internal pilot)
----------	---------------------------------------

Note 1) When selecting the flush type, it is not necessary to select the suffix for the actuator.

Construction

Non-actuated

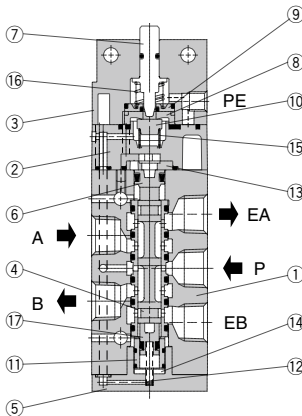

Actuated

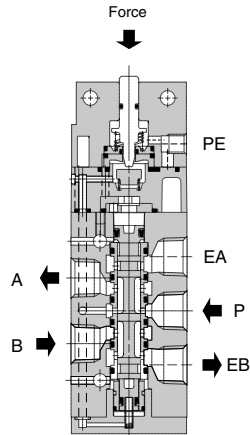

Component Parts

No.	Description	Material	Note
1	Body	ADC	Platinum silver
2	Pilot body	PBT	ZDC only for external pilot type
3	Head cover	ZDC	Black zinc chromated
4	Spool/sleeve	Stainless steel	
5	End cover	POM	
6	Piston A	POM	
7	Plunger	POM	
8	Valve seat (A)	POM	
9	Valve seat (B)	POM	

No.	Description	Material	Note
10	Valve	NBR	
11	Piston guide B	Aluminum alloy	
12	Return spring	Stainless steel	
13	Cushion	Rubber	
14	Cushion	Rubber	
15	Valve spring	Stainless steel	
16	Return spring	Stainless steel	
17	Piston B	POM	

VZM400 Series

VZM400 Series

Twist selector (2 position) / VZM450-01-34R/B/G/Y

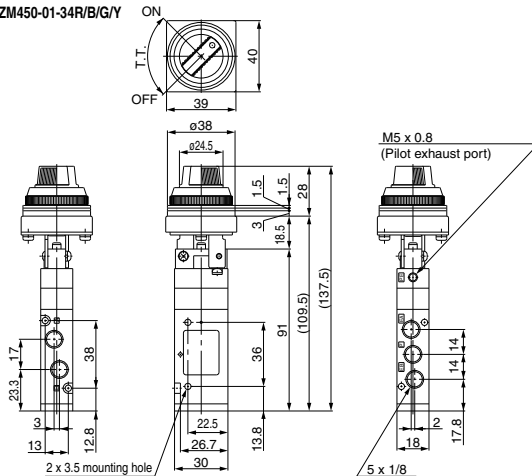

Panel mounting hole

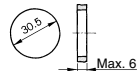

Symbol

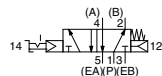

* 0.5 MPa supply

F.O.F. *	23 N
T.T.	90°

Key selector (2 position) / VZM450-01-36

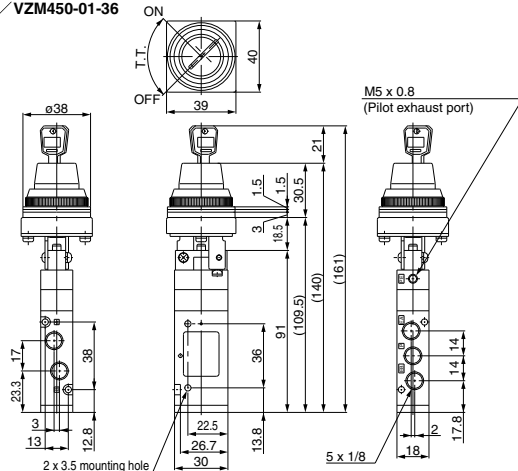

Panel mounting hole

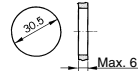

Symbol

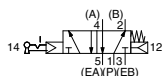

* 0.5 MPa supply

F.O.F. *	26 N
T.T.	90°

Key can be removed at the "on" and "off" positions.

External pilot type
VZM451 type

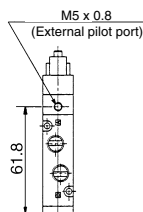

With foot bracket
VZM450-01-□□-F

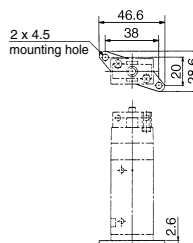

5 Port Mechanical Valve Rubber Seal

VZM500 Series



**Compact design,
large flow capacity
High cycle rate,
long life/300 c.p.m. or less
Piping possible to any EXH
port.**

Proper countermeasures can be taken for applications in which the noise of the exhaust could cause problems to the surroundings.

**Pilot type is selectable.
(Internal pilot and external pilot)**

**Foot bracket and manifold
mounting possible.**



PAT. PEND.

Specifications

Fluid	Air			
Operating pressure	0.15 to 0.7 MPa (1)			
Ambient and fluid temperature	-5 to 60°C (No freezing)			
Flow rate characteristics	C[dm ³ /(s·bar)]	b	Cv	
	1(P)→2(B)/4(A)	2.2	0.36	0.58
	2(B)/4(A)→4(R2)/5(R1)	2.4	0.34	0.63
Maximum frequency (Mechanical operation type)	300 c.p.m. or less			
Lubrication	Not required (Use turbine oil Class 1 ISO VG32, if lubricated.)			
Port size	Main valve 1/8			
	Pilot valve (EXH)/M5 x 0.8			
Option	Foot bracket (2)			

* Please contact SMC for manifold mounting type.

Note 1) External pilot type Main valve: 0 to 0.7 MPa

Pilot valve: 0.15 to 0.7 MPa

Note 2) The standard body can not be retrofitted with a foot bracket.

Model

	Actuator	Model	Actuator part no.	Application	Weight (g)
Mechanical operation	Basic	VZM550-01-00	—	—	110
	Roller lever	VZM550-01-01	VM-01C	Polyacetal roller	140
		VZM550-01-01S	VM-01CS	Hard steel roller	150
	One way roller lever	VZM550-01-02	VM-02C	Polyacetal roller	150
		VZM550-01-02S	VM-02CS	Hard steel roller	160
	Straight plunger	VZM550-01-05	VM-05C	—	180
Roller plunger	VZM550-01-06	VM-06C	Polyacetal roller	180	
	VZM550-01-06S	VM-06CS	Hard steel roller	180	
Toggle lever	VZM550-01-08	VM-08C	—	170	
Manual operation	Push button (Mushroom)	VZM550-01-30R	VM-30CR	Red	179
		VZM550-01-30B	VM-30CB	Black	
		VZM550-01-30G	VM-30CG	Green	
	Push button (Extended)	VZM550-01-30Y	VM-30CY	Yellow	172
		VZM550-01-32R	VM-32CR	Red	
		VZM550-01-32B	VM-32CB	Black	
		VZM550-01-32G	VM-32CG	Green	
	Push button (Flush)	VZM550-01-32Y	VM-32CY	Yellow	177
		VZM550-01-33	VM-33C	With a set of red, black, green, yellow	
	Twist selector (2 position)	VZM550-01-34R	VM-34CR	Red	178
		VZM550-01-34B	VM-34CB	Black	
		VZM550-01-34G	VM-34CG	Green	
VZM550-01-34Y		VM-34CY	Yellow		
Key selector (2 position)	VZM550-01-36	VM-36C	—	197	
Push-pull	VZM550-01-37	—	Black	170	

Note 1) Actuator replacement is available for all types. (Except push-pull)

Note 2) For push button (mushroom), push button (extended), push button (flush) and a single unit of fastening ring, refer to pages 1655 and 1656. The other parts are not replaceable.

Note 3) The handle of the selector (2 position) cannot be removed or replaced alone.

VM

VMG

VR

VR51

VHK

VH

VHS □

VHS

VZM500 Series

How to Order

VZM55 0 - 01 - 01 S - [] - []

• **Made to Order**

(Refer to pages 1648 to 1651 for details.)

X207	Alternate type, Mushroom push button
X219	Push-lock turn-reset type, Mushroom push button

• **Option**

F	Foot bracket
---	--------------

• **Suffix for actuator***

S	Hard steel roller	
R	Red	Color of push button selector
B	Black	
G	Green	
Y	Yellow	

* Refer to the table on page 1529 for combinations of actuator type and suffix.

• **Port size**

01	Rc 1/8
N01	NPT 1/8
F01	G 1/8

• **Body option**

0	Standard
1*	External pilot type

* Except VZM550-01-37

• **Actuator type***

00	Basic
01	Roller lever
02	One way roller lever
05	Straight plunger
06	Roller plunger
08	Toggle lever
30	Push button (Mushroom)
32	Push button (Extended)
33	Push button (Flush) ^{Note 1)}
34	Twist selector (2 position)
36	Key selector (2 position)
37	Push-pull

Note 1) When selecting the flush type, it is not necessary to select the suffix for the actuator.

Construction

Non-actuated

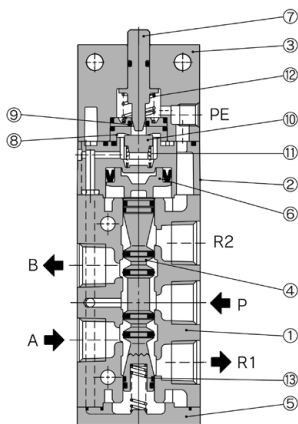

Actuated

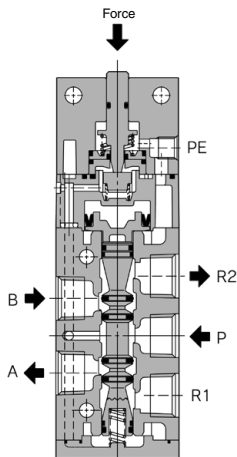

Component Parts

No.	Description	Material	Note
1	Body	ADC	Platinum silver
2	Pilot body	PBT	ZDC only for external pilot type
3	Head cover	ZDC	Black zinc chromated
4	Spool valve assembly		
5	End cover	ZDC	Matt-black
6	Piston	POM	
7	Plunger	POM	

No.	Description	Material	Note
8	Valve seat (A)	POM	
9	Valve seat (B)	POM	
10	Valve assembly	NBR	
11	Valve spring	Stainless steel	
12	Return spring	Stainless steel	
13	Spool spring	Stainless steel	

VZM500 Series

Basic
VZM550-01-00

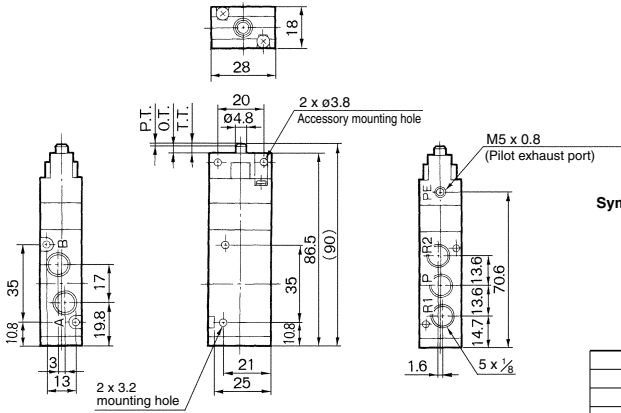

Symbol

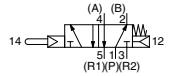

* 0.5 MPa supply

F.O.F.*	16 N
P.T.	1.0 mm
O.T.	2.0 mm
T.T.	3.0 mm

Roller lever
VZM550-01-01
VZM550-01-01S

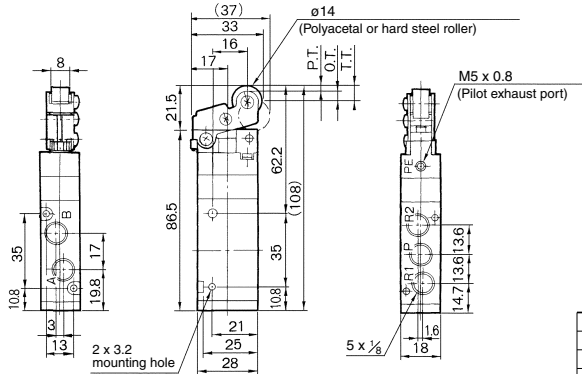

Symbol

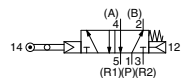

* 0.5 MPa supply

F.O.F.*	8 N
P.T.	2.2 mm
O.T.	4.0 mm
T.T.	6.2 mm

One way roller lever
VZM550-01-02
VZM550-01-02S

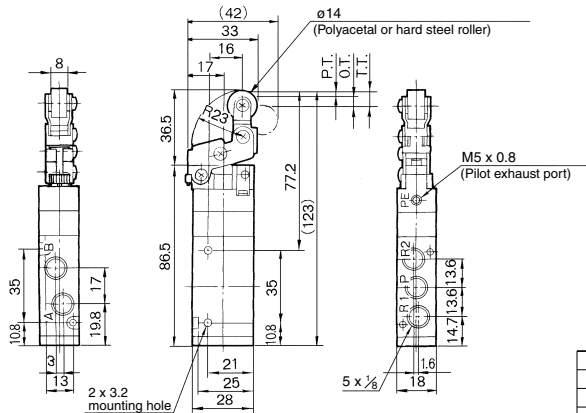

Symbol

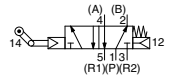

* 0.5 MPa supply

F.O.F.*	7 N
P.T.	2.4 mm
O.T.	4.6 mm
T.T.	7.0 mm

VZM500 Series

VZM500 Series

Straight plunger

VZM550-01-05

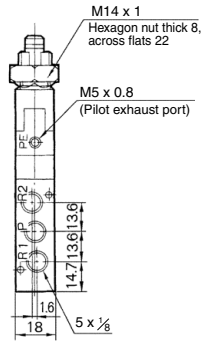
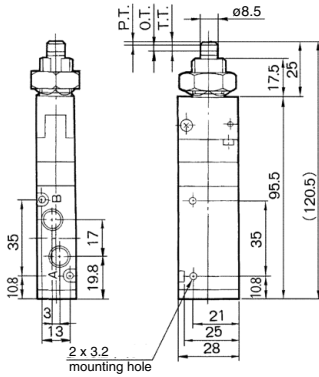

Panel mounting hole



Symbol

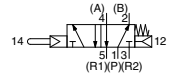

* 0.5 MPa supply

F.O.F.*	18 N
P.T.	1.5 mm
O.T.	2.0 mm
T.T.	3.5 mm

Roller plunger

VZM550-01-06

VZM550-01-06S

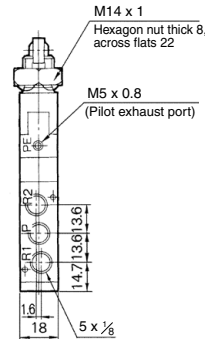
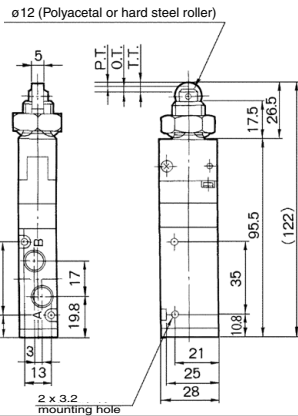

Panel mounting hole

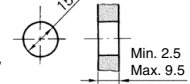

Symbol

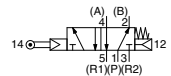

* 0.5 MPa supply

F.O.F.*	18 N
P.T.	1.5 mm
O.T.	2.0 mm
T.T.	3.5 mm

Toggle lever

VZM550-01-08

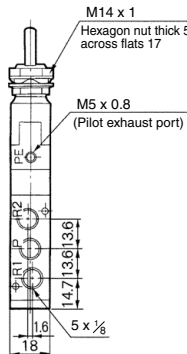
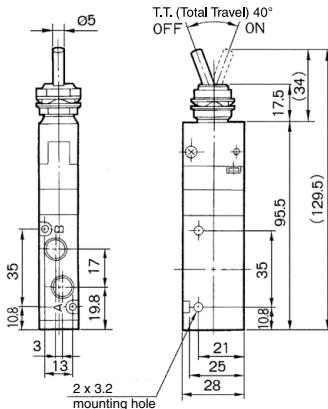

Panel mounting hole



Symbol

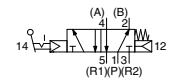

* 0.5 MPa supply

F.O.F.*	15 N
T.T.	40°

VZM500 Series

Push button (Mushroom)

VZM550-01-30R/B/G/Y

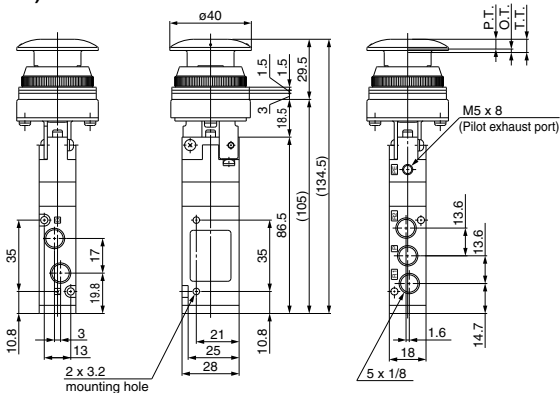

Panel mounting hole

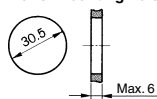

Symbol

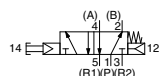

* 0.5 MPa supply

F.O.F.*	21 N
P.T.	4.8 mm
O.T.	1.7 mm
T.T.	6.5 mm

Push button (Extended)

VZM550-01-32R/B/G/Y

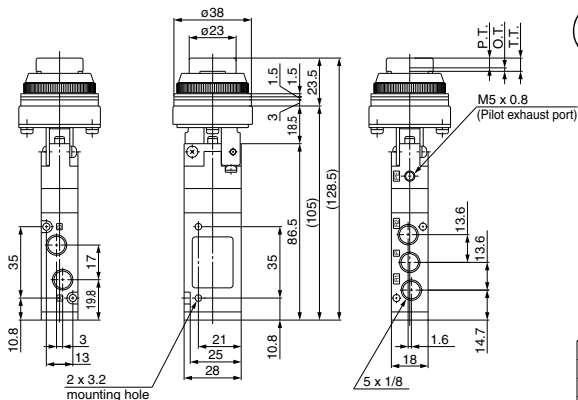

Panel mounting hole

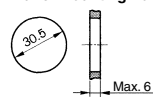

Symbol

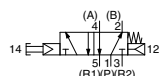

* 0.5 MPa supply

F.O.F.*	21 N
P.T.	4.8 mm
O.T.	1.7 mm
T.T.	6.5 mm

Push button (Flush)

VZM550-01-33

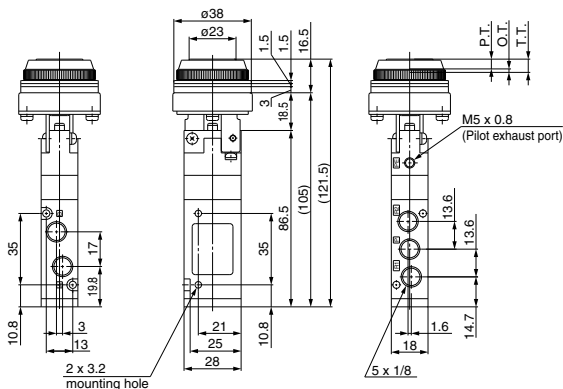

Panel mounting hole

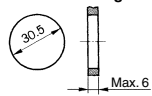

Symbol

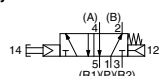

* 0.5 MPa supply

F.O.F.*	21 N
P.T.	4.8 mm
O.T.	1.7 mm
T.T.	6.5 mm

VM

VMG

VR

VR51

VHK

VH

VHS □

VHS

VZM500 Series

VZM500 Series

Selector (2 position) VZM550-01-34R/B/G/Y

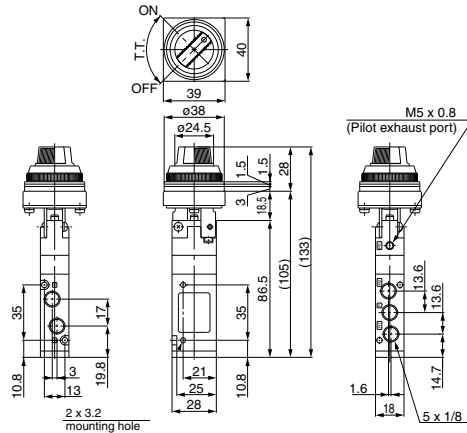

Panel mounting hole

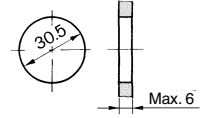

Symbol

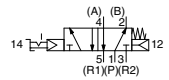

* 0.5 MPa supply

F.O.F.*	23 N
T.T.	90°

Key selector (2 position) VZM550-01-36

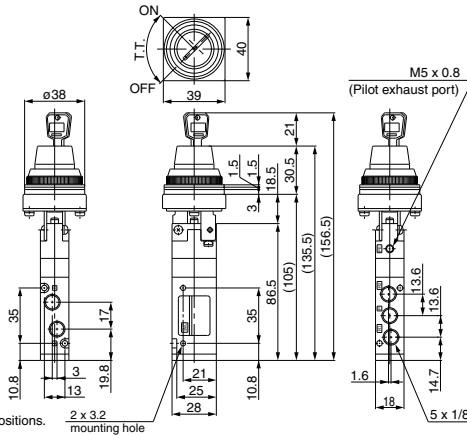

Panel mounting hole

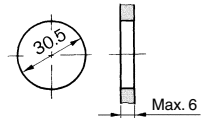

Symbol

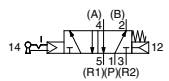

* 0.5 MPa supply

F.O.F.*	26 N
T.T.	90°

Key can be removed at the "on" and "off" positions.

Push pull VZM550-01-37

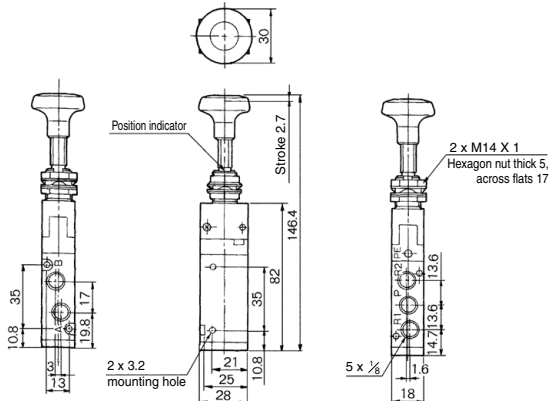

Panel mounting hole

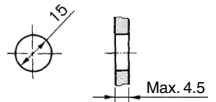

Symbol

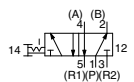

F.O.F.	20 N
T.T.	2.7 mm

External pilot type
VZM551 type

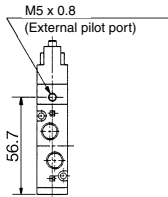

With foot bracket
VZM55□-01-□-□-F

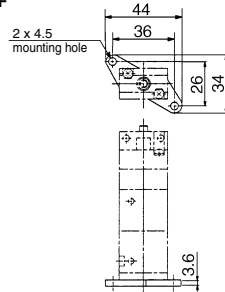

VM
VMG
VR
VR51
VHK
VH
VHS□
VHS

5 Port Mechanical Valve Rubber Seal

VFM300 Series



**Compact design,
large flow capacity
High cycle rate,
long life/300 c.p.m. or less
Piping possible to any EXH
port.**

Proper countermeasures can be taken for applications in which the noise of the exhaust could cause problems to the surroundings.

**Pilot type is selectable.
(Internal pilot and external pilot)**



Specifications

Fluid	Air			
Operating pressure	0.15 to 0.9 MPa ⁽¹⁾			
Ambient and fluid temperature	-5 to 60°C (No freezing)			
Flow rate characteristics	C[dm ³ /(s·bar)]	b	Cv	
	1(P)→2(C2)/4(C1)	4.0	0.36	1.0
	2(C2)/4(C1)→3(E2)/5(E1)	3.1	0.32	0.75
Maximum frequency (Mechanical operation type)	300 c.p.m. or less			
Lubrication	Not required (Use turbine oil Class 1 ISO VG32, if lubricated.)			
Port size	Main valve/1P, 4A, 2B port 1/4, 5EA/3EB port 1/8			
	Pilot valve (EXH)/M5 x 0.8			
Option	Foot bracket ⁽²⁾			

Note 1) External pilot type Main valve: 0 to 0.9 MPa
Pilot valve: 0.15 to 0.9 MPa

Note 2) The standard body can not be retrofitted with a foot bracket.

Model

	Actuator	Model	Actuator part no.	Application	Weight (g)
Mechanical operation	Basic	VFM350-02-00	—	—	190
	Roller lever	VFM350-02-01	VM-01C	Polyacetal roller	270
		VFM350-02-01S	VM-01CS	Hard steel roller	280
	One way roller lever	VFM350-02-02	VM-02C	Polyacetal roller	280
		VFM350-02-02S	VM-02CS	Hard steel roller	290
	Straight plunger	VFM350-02-05	VM-05D	—	380
	Roller plunger	VFM350-02-06	VM-06D	Polyacetal roller	370
		VFM350-02-06S	VM-06DS	Hard steel roller	380
Manual operation	Toggle lever	VFM350-02-08	VM-08D	—	360
	Push button (Mushroom)	VFM350-02-30R	VM-30CR	Red	309
		VFM350-02-30B	VM-30CB	Black	
		VFM350-02-30G	VM-30CG	Green	
		VFM350-02-30Y	VM-30CY	Yellow	
	Push button (Extended)	VFM350-02-32R	VM-32CR	Red	302
		VFM350-02-32B	VM-32CB	Black	
		VFM350-02-32G	VM-32CG	Green	
	Push button (Flush)	VFM350-02-32Y	VM-32CY	Yellow	307
		VFM350-02-33	VM-33C	With a set of red, black, green, yellow	
		VFM350-02-34R	VM-34CR	Red	
	Twist selector (2 position)	VFM350-02-34B	VM-34CB	Black	308
		VFM350-02-34G	VM-34CG	Green	
		VFM350-02-34Y	VM-34CY	Yellow	
	Key selector (2 position)	VFM350-02-36	VM-36C	—	327

Note 1) Actuator replacement is available for all types.

Note 2) For push button (mushroom), push button (extended), push button (flush) and a single unit of fastening ring, refer to pages 1655 and 1656. The other parts are not replaceable.

Note 3) The handle of the selector (2 position) cannot be removed or replaced alone.

How to Order

VFM35 0 - 02 - 01 S - [] - []

● **Made to Order**
(Refer to pages 1648 to 1651 for details.)

X207	Alternate type, Mushroom push button
X219	Push-lock turn-reset type, Mushroom push button

● **Option**

F	Foot bracket (Only internal pilot)
----------	---------------------------------------

● **Port size**

02	Rc 1/4
N02	NPT 1/4
F02	G 1/4

● **Actuator type***

00	Basic
01	Roller lever
02	One way roller lever
05	Straight plunger
06	Roller plunger
08	Toggle lever
30	Push button (Mushroom)
32	Push button (Extended)
33	Push button (Flush) <small>Note 1)</small>
34	Twist selector (2 position)
36	Key selector (2 position)

● **Suffix for actuator***

S	Hard steel roller	Color of push button selector
R	Red	
B	Black	
G	Green	
Y	Yellow	

* Refer to the table on page 1636 for combinations of actuator type and suffix.

● **Body option**

0	Internal pilot type
1	External pilot type

Note 1) When selecting the flush type, it is not necessary to select the suffix for the actuator.

Construction

Non-actuated

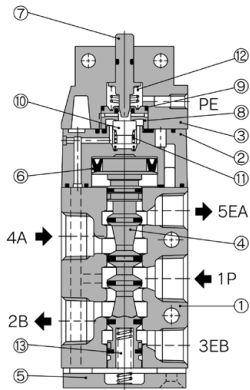

Actuated

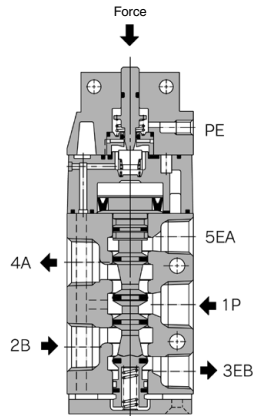

VM

VMG

VR

VR51

VHK

VH

VHS

VHS

Component Parts

No.	Description	Material	Note
1	Body	ADC	Platinum silver
2	Pilot body	PBT	ZDC only for external pilot type
3	Head cover	ZDC	Black zinc chromated
4	Spool valve assembly		
5	End cover	ADC	Matt-black
6	Piston	POM	
7	Plunger	POM	

No.	Description	Material	Note
8	Valve seat (A)	POM	
9	Valve seat (B)	POM	
10	Valve	NBR	
11	Valve spring	Stainless steel	
12	Return spring	Stainless steel	
13	Spool spring	Stainless steel	

VFM300 Series

VFM300 Series

Basic VFM350-02-00

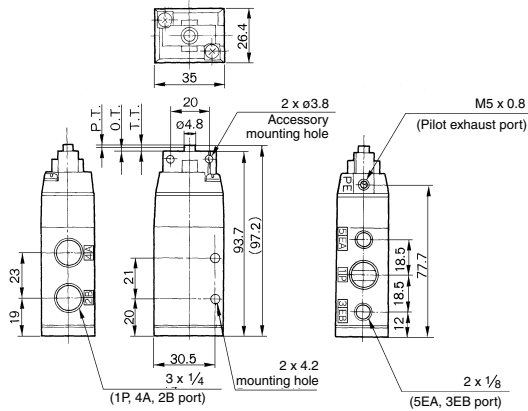

Symbol

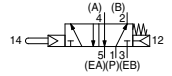

* 0.5 MPa supply

F.O.F.*	16 N
P.T.	1.0 mm
O.T.	2.0 mm
T.T.	3.0 mm

Roller lever VFM350-02-01 VFM350-02-01S

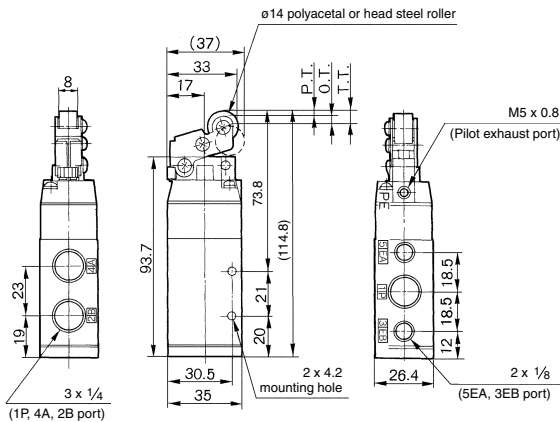

Symbol

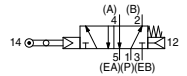

* 0.5 MPa supply

F.O.F.*	8 N
P.T.	2.2 mm
O.T.	4.0 mm
T.T.	6.2 mm

One way roller lever VFM350-02-02 VFM350-02-02S

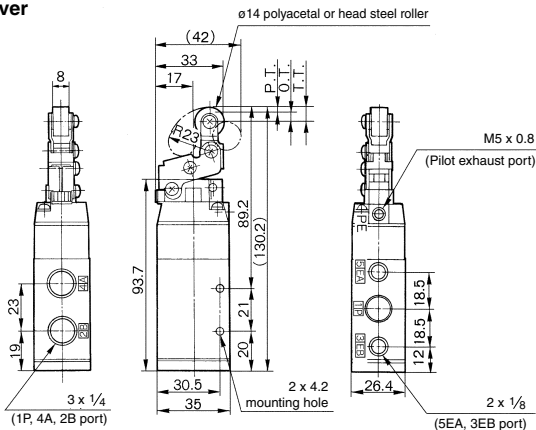

Symbol

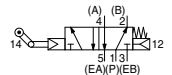

* 0.5 MPa supply

F.O.F.*	7 N
P.T.	2.4 mm
O.T.	4.6 mm
T.T.	7.0 mm

5 Port Mechanical Valve Rubber Seal **VFM300 Series**

VFM300 Series

Straight plunger VFM350-02-05

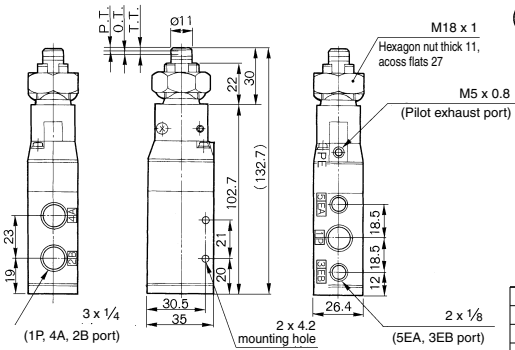

Panel mounting hole

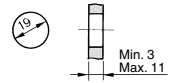

Symbol

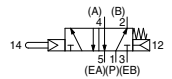

* 0.5 MPa supply

F.O.F. *	20 N
P.T.	1.5 mm
O.T.	2.0 mm
T.T.	3.5 mm

Roller plunger VFM350-02-06 VFM350-02-06S

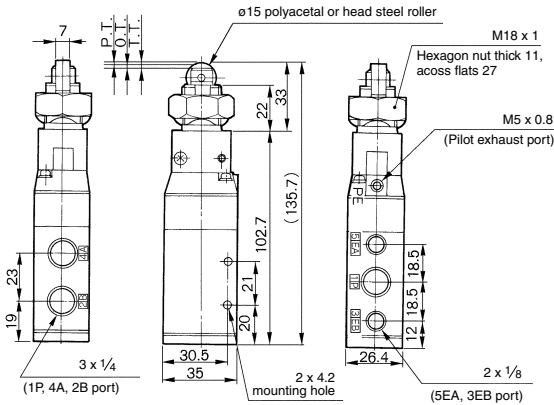

Panel mounting hole

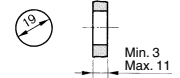

Symbol

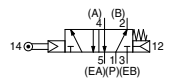

* 0.5 MPa supply

F.O.F. *	20 N
P.T.	1.5 mm
O.T.	2.0 mm
T.T.	3.5 mm

Toggle lever VFM350-02-08

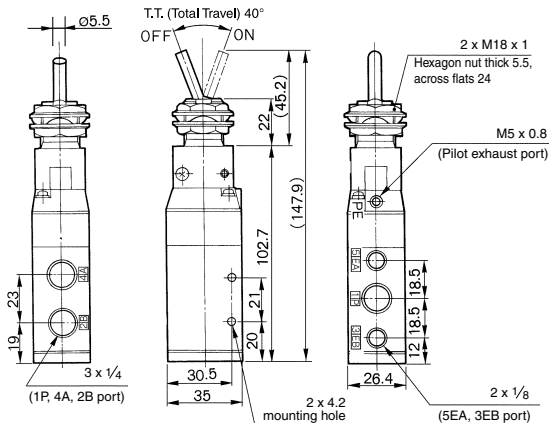

Panel mounting hole

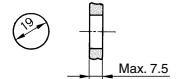

Symbol

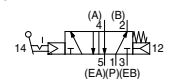

* 0.5 MPa supply

F.O.F. *	15 N
T.T.	40°

VFM300 Series

VFM300 Series

Push button (Mushroom)

VFM350-02-30R/B/G/Y

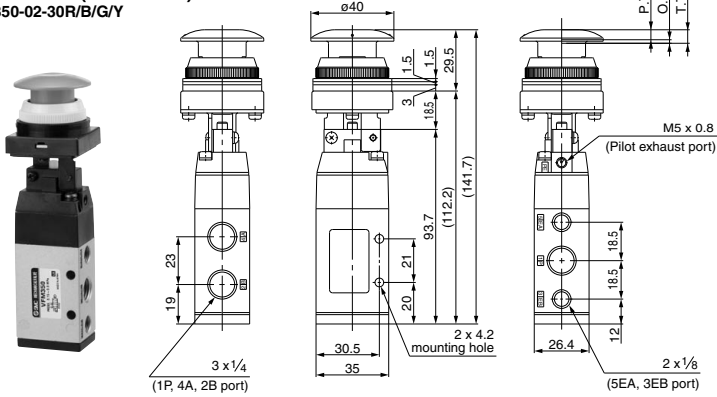

Panel mounting hole

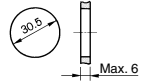

Symbol

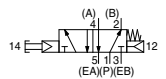

* 0.5 MPa supply

F.O.F.*	21 N
P.T.	4.8 mm
O.T.	1.7 mm
T.T.	6.5 mm

Push button (Extended)

VFM350-02-32R/B/G/Y

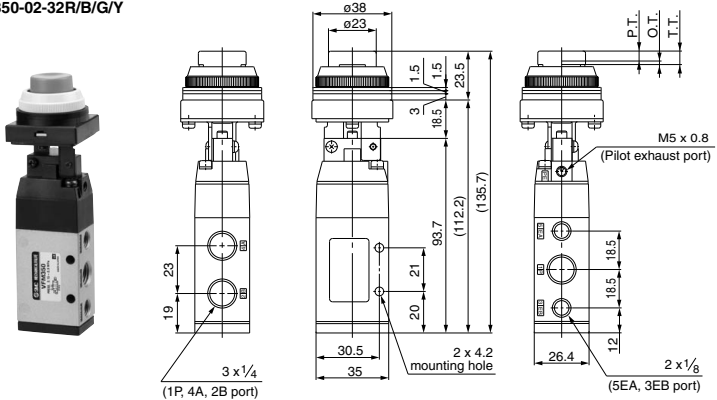

Panel mounting hole

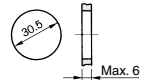

Symbol

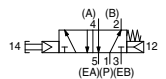

* 0.5 MPa supply

F.O.F.*	21 N
P.T.	4.8 mm
O.T.	1.7 mm
T.T.	6.5 mm

Push button (Flush)

VFM350-02-33

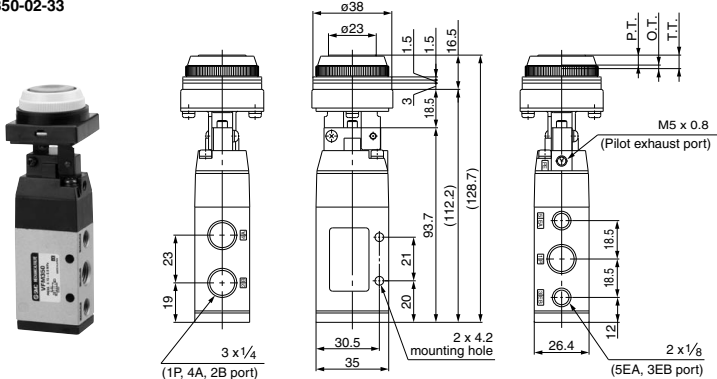

Panel mounting hole

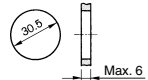

Symbol

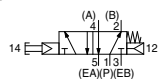

* 0.5 MPa supply

F.O.F.*	21 N
P.T.	4.8 mm
O.T.	1.7 mm
T.T.	6.5 mm

5 Port Mechanical Valve Rubber Seal **VFM300 Series**

VFM300 Series

Twist selector (2 position) VFM350-02-34R/B/G/Y

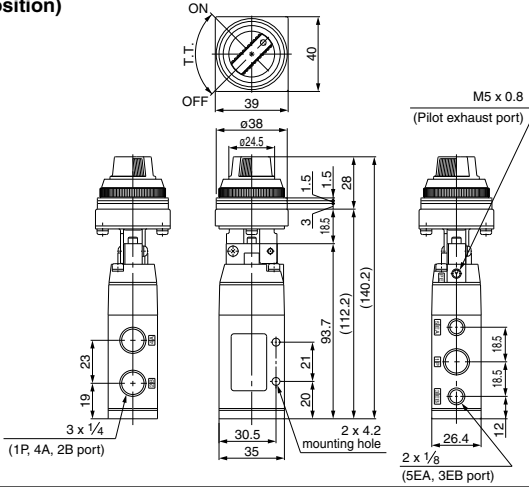

Panel mounting hole

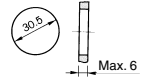

Symbol

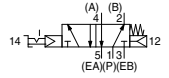

* 0.5 MPa supply

F.O.F.*	23 N
T.T.	90°

Key selector (2 position) VFM350-02-36

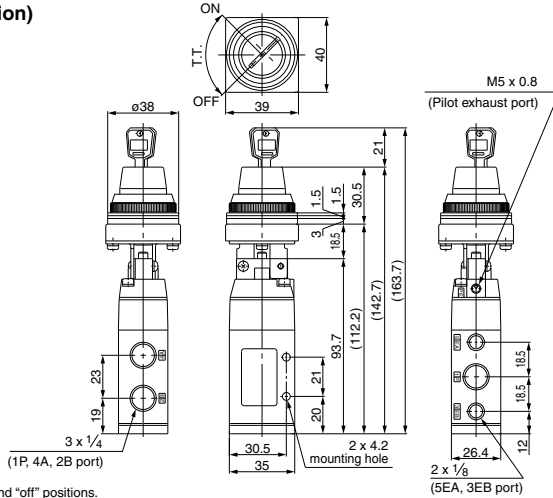

Panel mounting hole

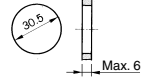

Symbol

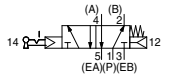

* 0.5 MPa supply

F.O.F.*	26 N
T.T.	90°

Key can be removed at the "on" and "off" positions.

External pilot type VFM351 type

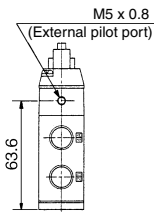

With foot bracket VFM350-02-□-F

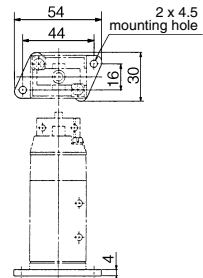

5 Port Mechanical Valve Metal Seal **VFM200 Series**



**Compact design,
large flow capacity
High cycle rate,
long life/300 c.p.m. or less
Piping possible to any EXH
port.**

Proper countermeasures can be taken for applications in which the noise of the exhaust could cause problems to the surroundings.

**Pilot type is selectable.
(Internal pilot and external pilot)**



Specifications

Fluid	Air			
Operating pressure	0.1 to 1.0 MPa ⁽¹⁾			
Ambient and fluid temperature	-5 to 60°C (No freezing)			
Flow rate characteristics	C[dm ³ /(s·bar)]	b	Cv	
	1(P)→2(B)/4(A)	4.0	0.2	0.9
	2(B)/4(A)→4(EB)/5(EA)	3.5	0.32	0.85
Maximum frequency (Mechanical operation type)	300 c.p.m. or less			
Lubrication	Not required (Use turbine oil Class 1 ISO VG32, if lubricated.)			
Port size	Main valve Rc 1/4			
	Pilot valve (EXH)/M5 x 0.8			
Option	Foot bracket ⁽²⁾			

Note 1) External pilot type Main valve: 0 to 1.0 MPa
Pilot valve: 0.1 to 1.0 MPa

Note 2) The bracket can not be retrofitted later.

Model

	Actuator	Model	Actuator part no.	Application	Weight (g)
Mechanical operation	Basic	VFM250-02-00	—	—	300
	Roller lever	VFM250-02-01	VM-01C	Polyacetal roller	310
		VFM250-02-01S	VM-01CS	Hard steel roller	320
	One way roller lever	VFM250-02-02	VM-02C	Polyacetal roller	320
		VFM250-02-02S	VM-02CS	Hard steel roller	330
	Straight plunger	VFM250-02-05	VM-05D	—	420
Roller plunger	VFM250-02-06	VM-06D	Polyacetal roller	410	
	VFM250-02-06S	VM-06DS	Hard steel roller	420	
Manual operation	Toggle lever	VFM250-02-08	VM-08D	—	400
	Push button (Mushroom)	VFM250-02-30R	VM-30CR	Red	349
		VFM250-02-30B	VM-30CB	Black	
		VFM250-02-30G	VM-30CG	Green	
		VFM250-02-30Y	VM-30CY	Yellow	
	Push button (Extended)	VFM250-02-32R	VM-32CR	Red	342
		VFM250-02-32B	VM-32CB	Black	
		VFM250-02-32G	VM-32CG	Green	
		VFM250-02-32Y	VM-32CY	Yellow	
	Push button (Flush)	VFM250-02-33	VM-33C	With a set of red, black, green, yellow	347
		VFM250-02-34R	VM-34CR	Red	348
	Twist selector (2 position)	VFM250-02-34B	VM-34CB	Black	
		VFM250-02-34G	VM-34CG	Green	
	VFM250-02-34Y	VM-34CY	Yellow		
Key selector (2 position)	VFM250-02-36	VM-36C	—	367	

Note 1) Actuator replacement is available for all types.

Note 2) For push button (mushroom), push button (extended), push button (flush) and a single unit of fastening ring, refer to pages 1655 and 1656. The other parts are not replaceable.

Note 3) The handle of the selector (2 position) cannot be removed or replaced alone.

How to Order

VFM25 **0** - **02** - **01** **S** - [] - []

● **Made to Order**
(Refer to pages 1648 to 1651 for details.)

X207	Alternate type, Mushroom push button
X219	Push-lock turn-reset type, Mushroom push button

● **Option**

F	Foot bracket (Only internal pilot)
----------	---------------------------------------

● **Port size**

02	Rc 1/4
-----------	--------

● **Body option**

0	Internal pilot type
1	External pilot type

● **Actuator type***

00	Basic
01	Roller lever
02	One way roller lever
05	Straight plunger
06	Roller plunger
08	Toggle lever
30	Push button (Mushroom)
32	Push button (Extended)
33	Push button (Flush) <small>Note 1)</small>
34	Twist selector (2 position)
36	Key selector (2 position)

● **Suffix for actuator***

S	Hard steel roller	Color of push button selector
R	Red	
B	Black	
G	Green	
Y	Yellow	

* Refer to the table on page 1642 for combinations of actuator type and suffix.

Note 1) When selecting the flush type, it is not necessary to select the suffix for the actuator.

Construction

Non-actuated

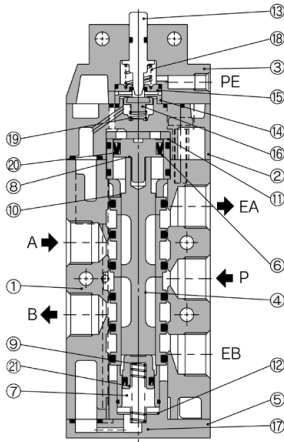

Actuated

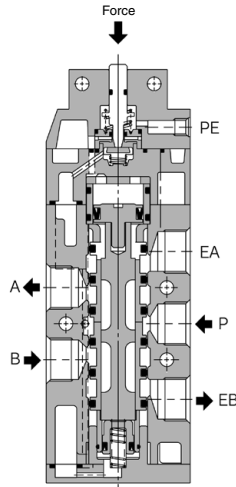

Component Parts

No.	Description	Material	Note
1	Body	ADC	Platinum silver
2	Pilot body	ZDC	Platinum silver
3	Head cover	ZDC	Black zinc chromated
4	Spool/sleeve	Stainless steel	
5	End cover	POM	
6	Piston guide	Brass	
7	Piston guide for end cover	Brass	
8	Piston	POM	
9	Piston for end cover	POM	
10	Guide bushing	POM	
11	Cushion	Urethane rubber	

No.	Description	Material	Note
12	Cushion for end cover	Urethane rubber	
13	Plunger	Stainless steel	
14	Valve seat (A)	POM	
15	Valve seat (B)	POM	
16	Valve	NBR	
17	Return spring	Stainless steel	
18	Return spring	Stainless steel	
19	Valve spring	Stainless steel	
20	Mini Y packing	NBR	
21	Mini Y packing	NBR	

- VM**
- VMG**
- VR**
- VR51**
- VHK**
- VH**
- VHS**
- VHS**

VFM200 Series

VFM200 Series

Basic VFM250-02-00

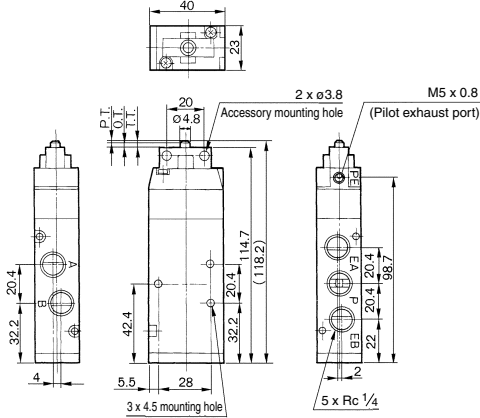

Symbol

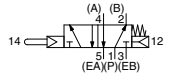

* 0.5 MPa supply

F.O.F.*	16 N
P.T.	1.0 mm
O.T.	2.0 mm
T.T.	3.0 mm

Roller lever VFM250-02-01 VFM250-02-01S

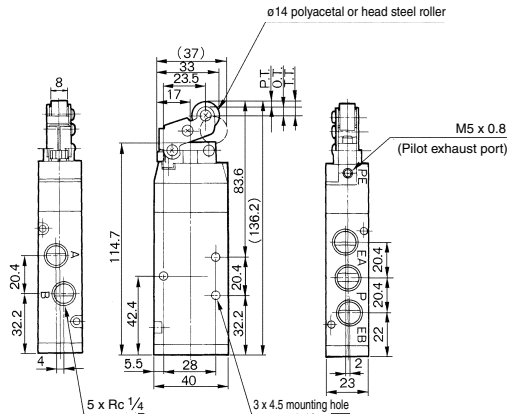

Symbol

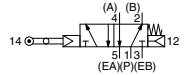

* 0.5 MPa supply

F.O.F.*	8 N
P.T.	2.2 mm
O.T.	4.0 mm
T.T.	6.2 mm

One way roller lever VFM250-02-02 VFM250-02-02S

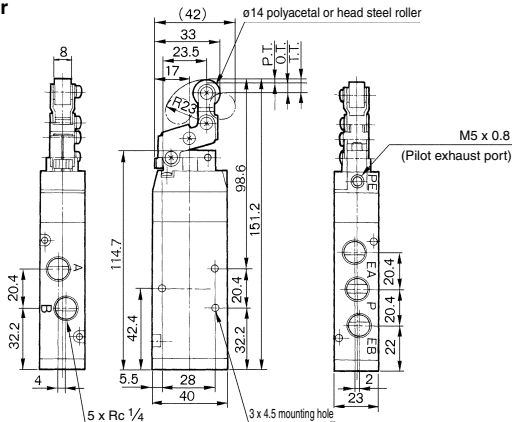

Symbol

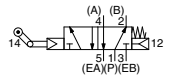

* 0.5 MPa supply

F.O.F.*	7 N
P.T.	2.4 mm
O.T.	4.6 mm
T.T.	7.0 mm

VFM200 Series

Straight plunger
VFM250-02-05

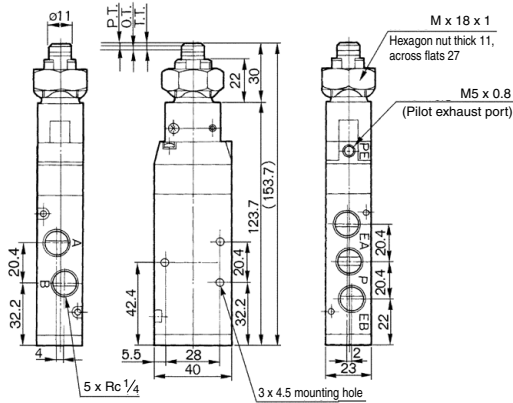

Panel mounting hole

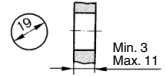

Symbol

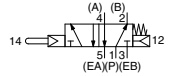

* 0.5 MPa supply

F.O.F. *	20 N
P.T.	1.5 mm
O.T.	2.0 mm
T.T.	3.5 mm

Roller plunger
VFM250-02-06
VFM250-02-06S

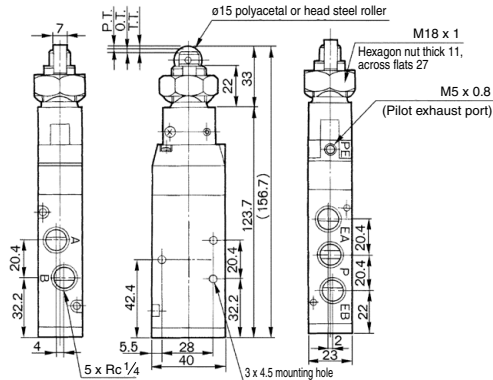

Panel mounting hole



Symbol

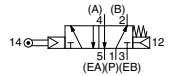

* 0.5 MPa supply

F.O.F. *	20 N
P.T.	1.5 mm
O.T.	2.0 mm
T.T.	3.5 mm

Toggle lever
VFM250-02-08

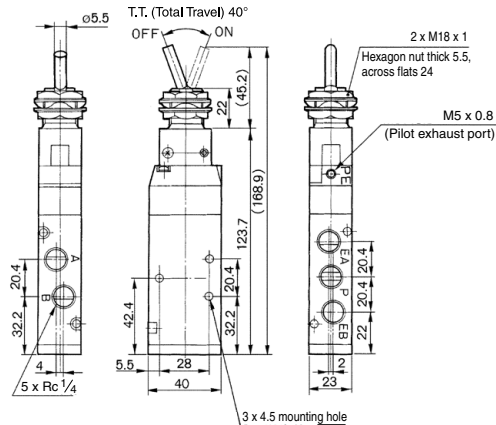

Panel mounting hole

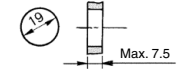

Symbol

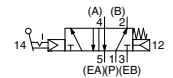

* 0.5 MPa supply

F.O.F. *	15 N
T.T.	40°

VFM200 Series

VFM200 Series

Push button (Mushroom)

VFM250-02-30R/B/G/Y

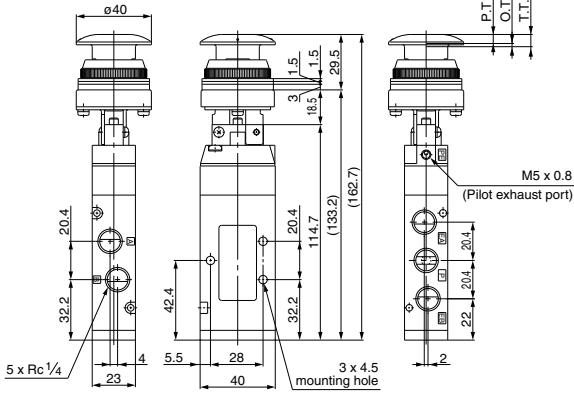

Panel mounting hole

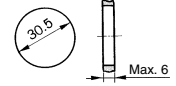

Symbol

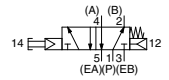

* 0.5 MPa supply

F.O.F.*	21 N
P.T.	4.8 mm
O.T.	1.7 mm
T.T.	6.5 mm

Push button (Extended)

VFM250-02-32R/B/G/Y

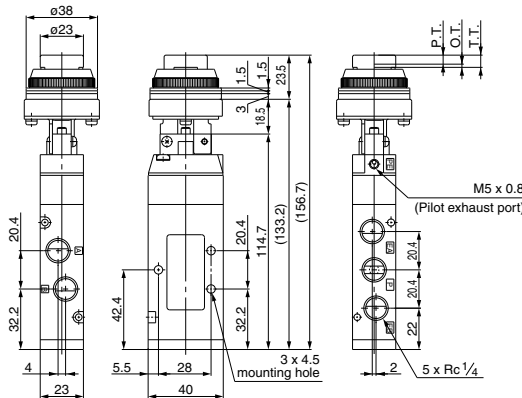

Panel mounting hole

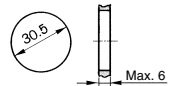

Symbol

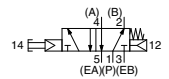

* 0.5 MPa supply

F.O.F.*	21 N
P.T.	4.8 mm
O.T.	1.7 mm
T.T.	6.5 mm

Push button (Flush)

VFM250-02-33

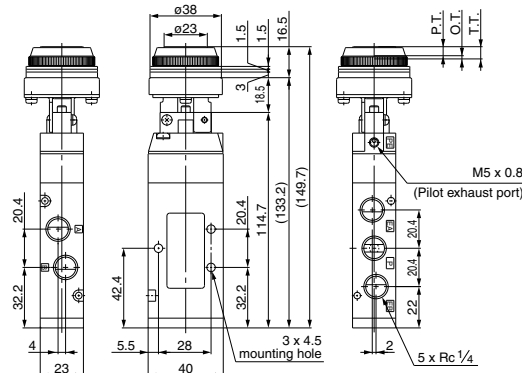

Panel mounting hole

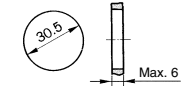

Symbol

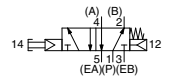

* 0.5 MPa supply

F.O.F.*	21 N
P.T.	4.8 mm
O.T.	1.7 mm
T.T.	6.5 mm

5 Port Mechanical Valve Metal Seal **VFM200 Series**

VFM200 Series

Twist selector (2 position) VFM250-02-34R/B/G/Y

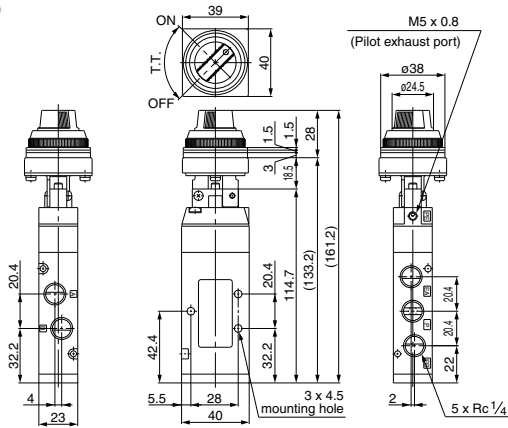

Panel mounting hole

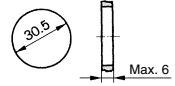

Symbol

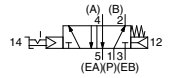

* 0.5 MPa supply

F.O.F.*	23 N
T.T.	90°

Key selector (2 position) VFM250-02-36

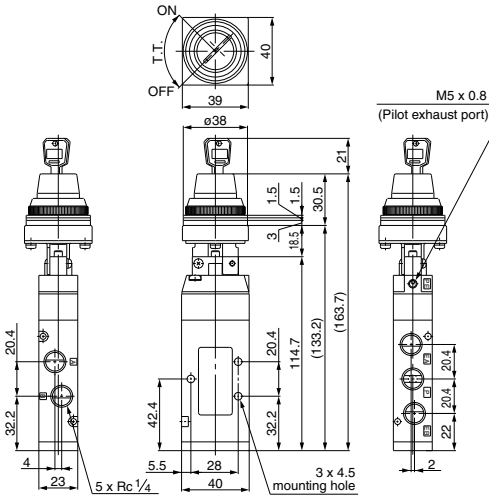

Panel mounting hole

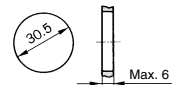

Symbol

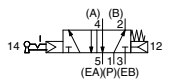

* 0.5 MPa supply

F.O.F.*	26 N
T.T.	90°

Key can be removed at the "on" and "off" positions.

External pilot type VFM251 type

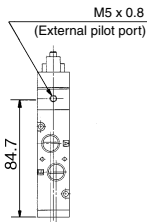

With foot bracket VFM250-02-□□-F

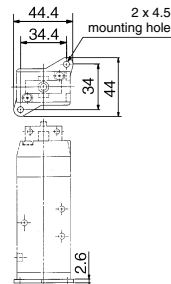



Alternate Type, Mushroom Push Button

X207

VFM350-02-30R/B/G/Y-X207

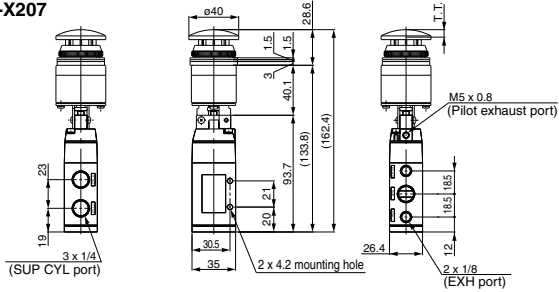

Panel mounting hole

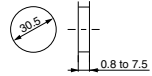

Symbol

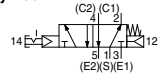

* 0.5 MPa supply

F.O.F. *	21 N
T.T.	6.7 mm

VFM250-02-30R/B/G/Y-X207

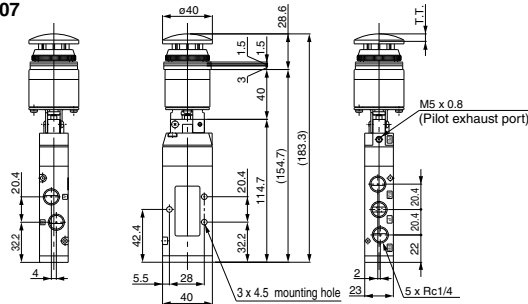

Panel mounting hole

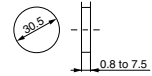

Symbol

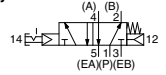

* 0.5 MPa supply

F.O.F. *	21 N
T.T.	6.7 mm

VM

VMG

VR

VR51

VHK

VH

VHS □

VHS



Push-lock Turn-reset Type, Mushroom Push Button

X219

Push-lock turn-reset type: When pressing the push button, it is locked in this status. Turning the button clockwise will reset it.

VM430-01-30R/B/G/Y-X219

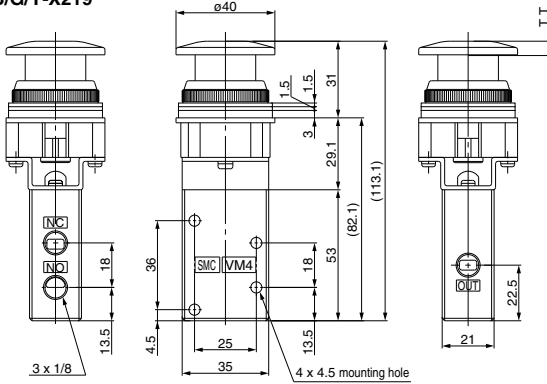

Panel mounting hole

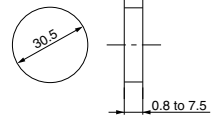

Symbol

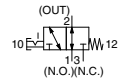

* 0.5 MPa supply

F.O.F. *	26 N
T.T.	5.8 mm

VZM450-01-30R/B/G/Y-X219

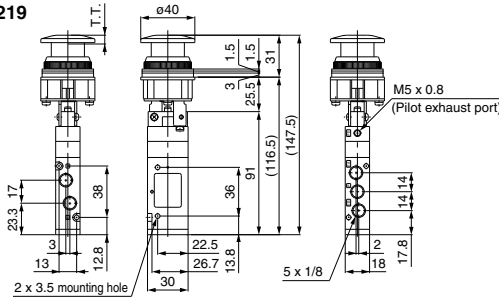

Panel mounting hole

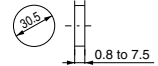

Symbol

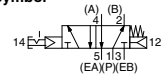

* 0.5 MPa supply

F.O.F. *	21 N
T.T.	5.8 mm

VZM550-01-30R/B/G/Y-X219

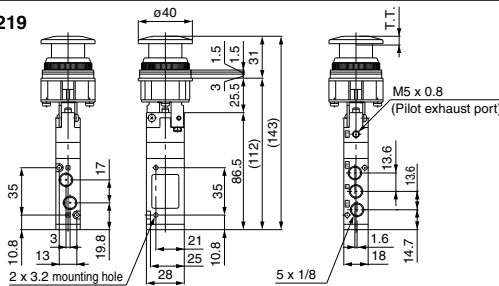

Panel mounting hole

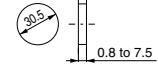

Symbol

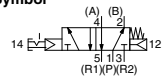

* 0.5 MPa supply

F.O.F. *	21 N
T.T.	5.8 mm



Push-lock Turn-reset Type, Mushroom Push Button

X219

VFM350-02-30R/B/G/Y-X219

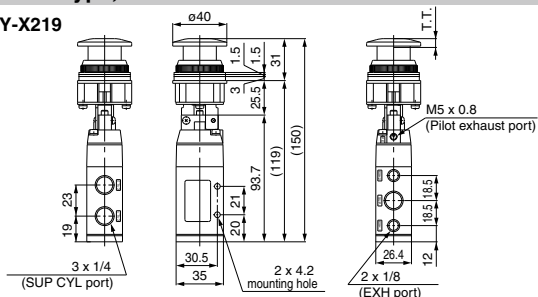

Panel mounting hole

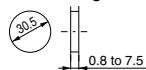

Symbol

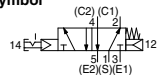

* 0.5 MPa supply

F.O.F. *	21 N
T.T.	5.8 mm

VFM250-02-30R/B/G/Y-X219

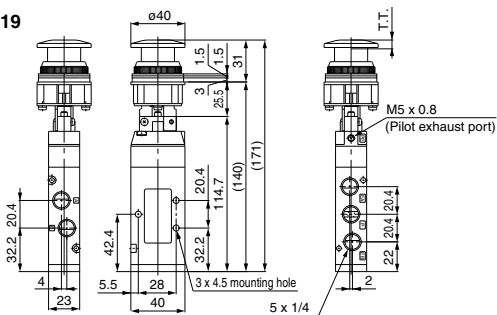

Panel mounting hole

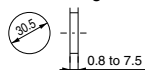

Symbol

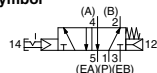

* 0.5 MPa supply

F.O.F. *	21 N
T.T.	5.8 mm

VM

VMG

VR

VR51

VHK

VH

VHS

VHS

VM Series Made to Order 5

Please contact SMC for detailed dimensions, specifications and lead times.



RoHS

Foot Pedal Type 5 Port Mechanical Valve

XT34-60/67

- 5 port is added to the foot pedal type mechanical valve.
- Models with lock and without lock are available.

Model

Model	XT34-60	XT34-67
Lock	With lock	Without lock
Weight	0.8 kg	0.5 kg

Specifications

Fluid	Air/Inert gas			
Operating pressure	0.15 to 0.9 MPa			
Ambient and fluid temperature	-5 to 60°C (No freezing)			
Flow rate characteristics	C [dm ³ /(s·bar)]	b	Cv	
	1(P) → 2(B)/4(A)	0.76	0.22	0.17
	2(B)/4(A) → 4(EB)/5(EA)	0.53	0.28	0.13
Lubrication	Not required (Use turbine oil Class 1 ISO VG32, if lubricated)			
Port size	Port 1(P), Port 2(B), Port 4(A): Rc1/8			
	Port 3(EB), Port 5(EA): M5 x 0.8			

XT34-60 (With lock)



Symbol

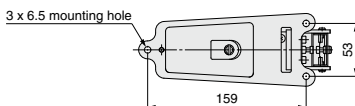
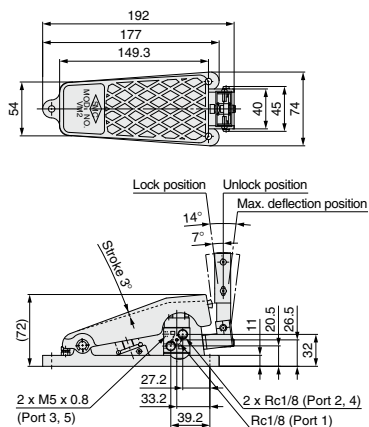
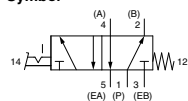

Travel required for operation	3°
Full Operating Force (F.O.F.)	55 N (at 0.5 MPa)
Travel required to release the lock	7°
Force required to release the lock (F.O.F.)	3.5 N

Operation

Locked

When stepping on the pedal, it is locked by the lock lever, and held in a locked state.

Unlocked

When pushing the lock lever with the toe, the lock is released, and the pedal returns to its original position.

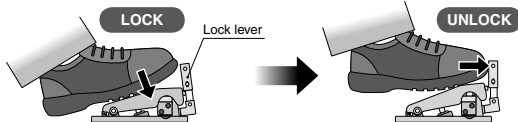

XT34-67 (Without lock)



Symbol

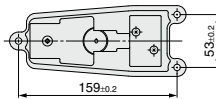
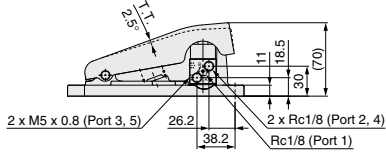
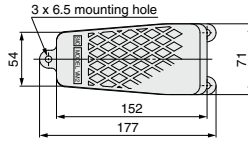
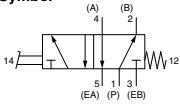

Total Travel (T.T.)	2.5°
Full Operating Force (Reference value)(F.O.F.)	55 N (at 0.5 MPa)

- VM**
- VMG**
- VR**
- VR51**
- VHK**
- VH**
- VHS**
- VHS**



VM Series

Specific Product Precautions 1

Be sure to read this before handling the products.

Refer to back page 50 for Safety Instructions and pages 3 to 9 for 3/4/5 Port Solenoid Valve Precautions.

Definition of Symbol

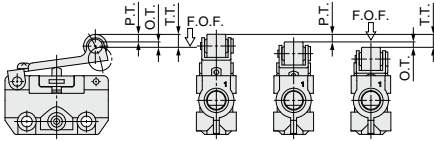
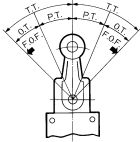

- **F.O.F. <Full Operating Force>**
Required force to total travel position
- **P.T. <Pre-travel>**
From free position to initial valve operating position
- **O.T. <Over Travel>**
From initial valve operating position to total travel position
- **T.T. <Total Travel>**
From free position to total travel position

Design

Warning

- This product cannot be used for applications in which the pressure must be sealed.**
Since mechanical valves are subject to minimal air leakage, they cannot be used for applications that require holding pressure (including vacuum).
- Not suitable for use as an emergency shutoff valve**
This mechanical valve is not designed for safety applications such as an emergency shutoff valve. If the valves are used for the mentioned applications, additional safety measures should be adopted.

Mounting

Warning

- Mount the mechanical operation type mechanical valve so that the valve does not operate over the operating limit range.**
Failure to do so may result in damage to the mechanical valve itself or lead to equipment malfunction.
- Operate the mechanism within the stroke range that has been obtained through the formula given below. (Do not move beyond the operating limit position.)**

Actuator stroke = (P.T. + 0.5 x O.T.) to (P.T. + O.T. - 0.1)

Series	Actuator		Actuator stroke (mm)
VM1000	Basic	T.T. = 4.8 mm (T.T. = 2.5 mm)	3.7 to 4.7 (2.2 to 2.4)
	Roller lever		3.5 to 4.4
	One way roller lever		3.5 to 4.4
VM400	Basic		2.5 to 3.4
	Roller lever		6.2 to 8.2
	One way roller lever		6.5 to 8.7
	Straight plunger		4.5 to 5.4
	Roller plunger		4.5 to 5.4
	Cross roller plunger		4.5 to 5.4
VZM500 VZM400 VFM300 VFM200	Basic		2.0 to 2.9
	Roller lever		4.2 to 6.0
	One way roller lever		4.7 to 6.7
	Straight plunger		2.5 to 3.4
	Roller plunger		2.5 to 3.4

For the straight plunger and roller plunger, there are grooves indicating P.T. and T.T. for stroke adjustment.

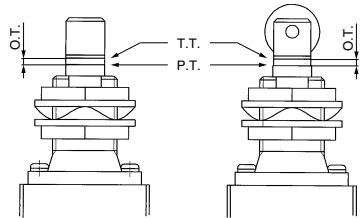

- Never perform additional machining such as enlarging the body mounting holes.**

As doing so could lead to unexpected abnormal conditions such as air leakage.

For specific product precautions of the VM100/200 series, refer to pages 1610 to 1613.



VM Series

Specific Product Precautions 2

Be sure to read this before handling the products.

Refer to back page 50 for Safety Instructions and pages 3 to 9 for 3/4/5 Port Solenoid Valve Precautions.

Operation

Warning

- When using a mechanical operation type mechanical valve, select the angle and the maximum speed limit of the cam and dog so that the valve does not exceed the following maximum values.

If operated over the maximum values, impact force from the cam and dog will be applied to the actuator, resulting in damage.

Series	Actuator	Angle limit switch actuator	Max. speed limit switch actuator (m/s)
VM1000	Roller lever	30°	0.7
		45°	0.3
	One way roller lever	30°	0.7
		45°	0.3
VM400	Roller lever	30°	0.7
		45°	0.3
	One way roller lever	30°	0.7
		45°	0.3
	Straight plunger	—	0.2
	Roller plunger	30°	0.3
Cross roller plunger	30°	0.3	
VZM500 VZM400 VFM300 VFM200	Roller lever	30°	1.5
		45°	0.7
	One way roller lever	30°	0.7
		45°	0.3
Straight plunger	—	0.4	
Roller plunger	30°	0.7	
VM800	Roller lever	30°	0.5
		45°	0.2
		30°	0.2
	Adjustable roller lever	30°	0.1
		45°	0.1
Adjustable rod lever	—	0.2	

[Not acceptable]

Over 45° (Abrupt angle)

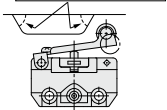

[Acceptable]

45° or less

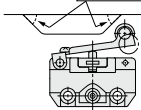

[Not acceptable]

Max. travel

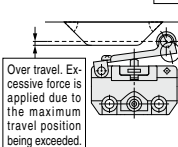

- Be sure to always operate push button type, twist selector type, and toggle lever type mechanical valves with your finger.

The use of tools such as hammers and equipment such as cylinders and cams to operate the product can damage the actuator and the valve body.

[Acceptable]

Max. travel

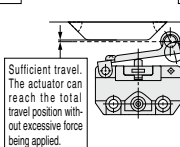

Operation

Warning

- Operate the roller lever type from the direction shown below. In cases where the dog goes over the actuator, select the one way roller lever type or the roller plunger type.

[Not acceptable]

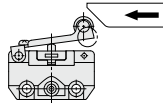

[Acceptable]

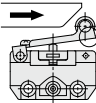

- As the VZM and VFM series are pilot operated mechanical valves, when primary pressure is no longer being supplied due to the current operating state, the built-in spring will return the main valve to the non-operating state position. For this reason, when the supply of primary pressure is resumed, in the times it takes for the pilot pressure to be recovered, there may be some instantaneous output from 1 → 2 (P → B).

Caution

- If the operating condition is maintained for long periods of time, it may take some time for the valve to restart due to the adherence of the seals and there might be a delay for recovery.

Air Supply

Warning

- Operable fluid is either air or inert gas only. It cannot be used for corrosive gas and fluid.

Caution

- Grease is used for the inside of the valves. Grease may enter into the outlet port of the valve.

Operating Environment

Warning

- Do not operate it in an area in which fluids such as oil, coolant, or water splash on it or dust comes in contact with it. Because it does not have a waterproof or dustproof construction, fluids or dust could enter the valve, leading to malfunction. Therefore, take measures such as providing a protective cover to prevent direct exposure.
- Do not expose the product to direct sunlight for an extended period of time.

Maintenance

Warning

- Perform inspections on a regular basis as necessary, such as at the beginning of an operation, to make sure that the mechanical valve operates properly.
- Do not disassemble, modify or repair the product. This may lead to malfunction of equipment, injury and equipment damage. Please contact SMC for repairs and maintenance of the product.

For specific product precautions of the VM100/200 series, refer to pages 1610 to 1613.



VM Series

Specific Product Precautions 3

Be sure to read this before handling the products.

Refer to back page 50 for Safety Instructions and pages 3 to 9 for 3/4/5 Port Solenoid Valve Precautions.

How to Change the Buttons

⚠ Caution

Replace the button in the following manner to change color of the button.

1. Push button (Flush type)

- Installation Of the four colors, red, green, black, and yellow, select and align the protruding portion of the button with the recessed portion of the body and push in.
- Removal Remove the fastening ring and insert the tip of a small flat screwdriver into the groove of the button to pry it up.

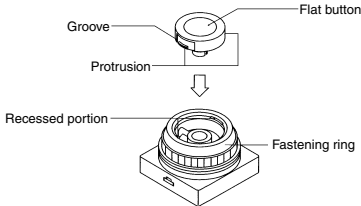

2. Push button (Mushroom and extended types)

At the time of shipment, only 1 button of the color that you specified is attached to the body.

	Mushroom type	Extended type
Mounting	Align the protruding portion of the button with the recessed portion of the body and push in. (Use the mark on the button as a reference to align the protruding part.)	Align the protruding portion of the button with the recessed portion of the body and push in.
Removal	Placing your finger under the collar of the button on the side of the mark, tilt it upward.	Remove the fastening ring and insert the tip of a small flat screwdriver into the groove of the button to pry it up.

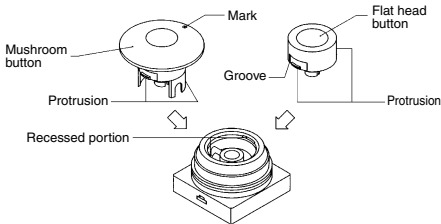

How to remove a mushroom button

How to remove at panel mount

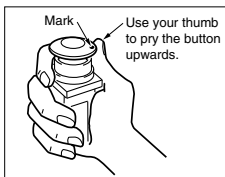
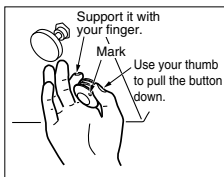

How to Change the Buttons

⚠ Caution

Replacement Parts

1. Use the part numbers listed below to order individual mushroom, extended, or flush type buttons.

Color	Mushroom type button	Extended type button	Flush type button
Red	3402186R	3402187R	3402188R
Black	3402186B	3402187B	3402188B
Green	3402186G	3402187G	3402188G
Yellow	3402186Y	3402187Y	3402188Y

2. To order single fastening ring, use the part number below.

Fastening ring: 3402184

3. To order a single push button for VM1000 series and a single cover use the part number below.

Color	Push button	Cover for push button
Red	3410701-R	3410703 (White only)
Black	3410701-B	
Green	3410701-G	

VM-X219, VZM-X219, VFM-X219 Series How to Mount Panel

[Task 1] Removal of the push button and fastening ring

Remove them from the body turning them counterclockwise in the order of the pushbutton and fastening ring.

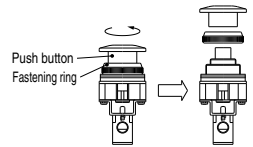

[Task 2] Mounting the valve to the panel

Insert the valve to the panel and fix it with a fastening ring. Remove three spacers attached to the valve depending on the panel thickness.

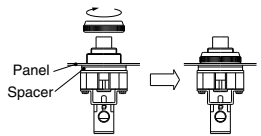

[Task 3] Mounting the push button

Tighten the push button clockwise by hand and further tighten it until load is applied.

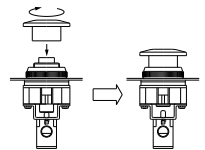

Note) When the push button is not tightened enough, the valve may not output correctly after operating the push button. In other cases, the valve outputs temporarily, but when it is in the holding state, the valve may stop outputting. In this situation, please tighten the push button again.

For specific product precautions of the VM100/200 series, refer to pages 1610 to 1613.