

NHD-12232WG-EYYH-V#A

Graphic Liquid Crystal Display Module

NHD-	Newhaven Display
12232-	122 x 32 pixels
WG-	Display Type: Graphic
E-	Model
Y-	Yellow/Green LED Backlight
Y-	STN- Yellow/Green
H-	Transflective, Wide Temperature
V#A-	Built-in DC-DC voltage converter

RoHS Compliant

Newhaven Display International, Inc.

2661 Galvin Ct.

Elgin IL, 60124

Ph: 847-844-8795

Fax: 847-844-8796

www.newhavendisplay.com

nhtech@newhavendisplay.com

nhsales@newhavendisplay.com

Document Revision History

Revision	Date	Description	Changed by
0	9/14/2006	Initial Release	-
1	3/16/2010	User guide reformat	BE
2	4/15/2010	Pin description update	BE
3	5/6/2010	Electrical, block diagram, initialization updated	BE
4	3/16/2015	Pin description & Example code updated	RM
5	1/6/16	Updated Wiring Diagram, Datasheet Reformat	SB
6	2/8/16	Updated Controller Information	SB
7	5/3/16	Electrical Characteristics, Response Time, Quality information updated	SB

Functions and Features

- 122 x 32 pixels
- Built-in SBN1661G_M02 Controller
- +3.0V power supply
- 1/32 duty cycle
- RoHS Compliant

Mechanical Drawing

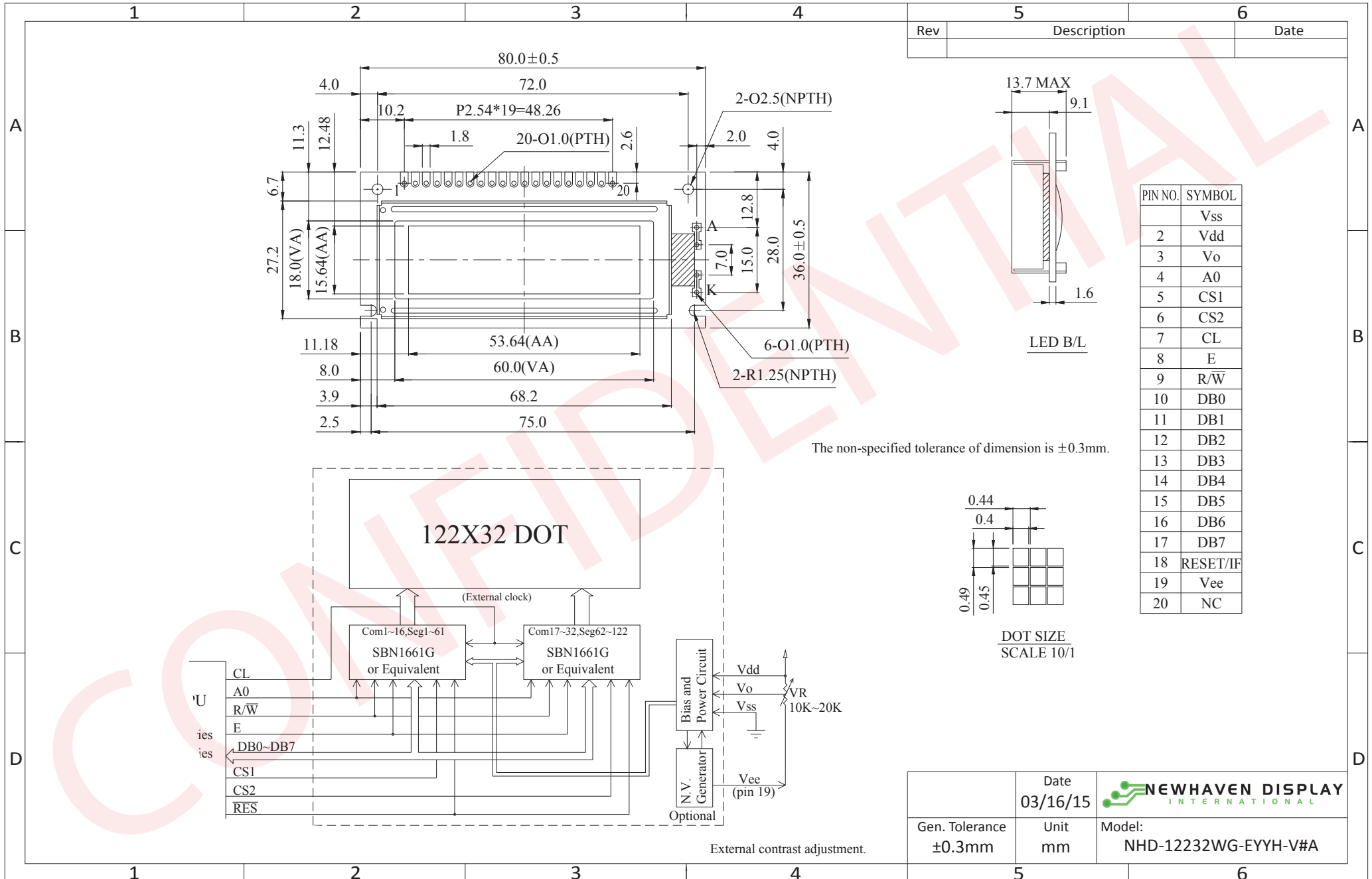

Rev	Description	Date

	Date 03/16/15	 NEWHAVEN DISPLAY INTERNATIONAL
Gen. Tolerance ±0.3mm	Unit mm	

The drawing contained herein is the exclusive property of Newhaven Display International, Inc. and shall not be copied, reproduced, and/or disclosed in any format without permission.

Pin Description and Wiring Diagram

Pin No.	Symbol	External Connection	Function Description
1	VSS	Power Supply	Ground
2	VDD	Power Supply	Supply voltage for logic (+3.0V)
3	V0	Adj Power Supply	Supply voltage for contrast (approx.- 1.5V)
4	A0	MPU	Register select signal. A0=0: Command, A0=1: Data
5	CS1	MPU	Active LOW Chip Select Signal for LEFT half of LCD
6	CS2	MPU	Active LOW Chip Select Signal for RIGHT half of LCD
7	CL	-	Clock Signal; Requires 2KHz external clock
8	E /RD	MPU	6800 Mode: Active HIGH Enable Signal 8080 Mode: Active LOW Read Signal
9	R/W /WR	MPU	6800 Mode: Read/Write select signal. R/W=1: Read R/W: =0: Write 8080 Mode: Active LOW Write Signal
10-17	DB0-DB7	MPU	This is an 8-bit Bi-directional data bus
18	RESET/IF	MPU	Hardware RESET (edge-sensitive) and interface type selection: Positive Reset: 8080 mode Negative Reset: 6800 mode
19	VEE	Power Supply	Negative voltage output (-3.0V)
20	NC	-	No Connect
A	LED+	Power Supply	Backlight Anode (+4.2V)
K	LED-	Power Supply	Backlight Cathode (Ground)

Recommended LCD connector: 2.54mm pitch pins

Backlight connector: - Mates with: -

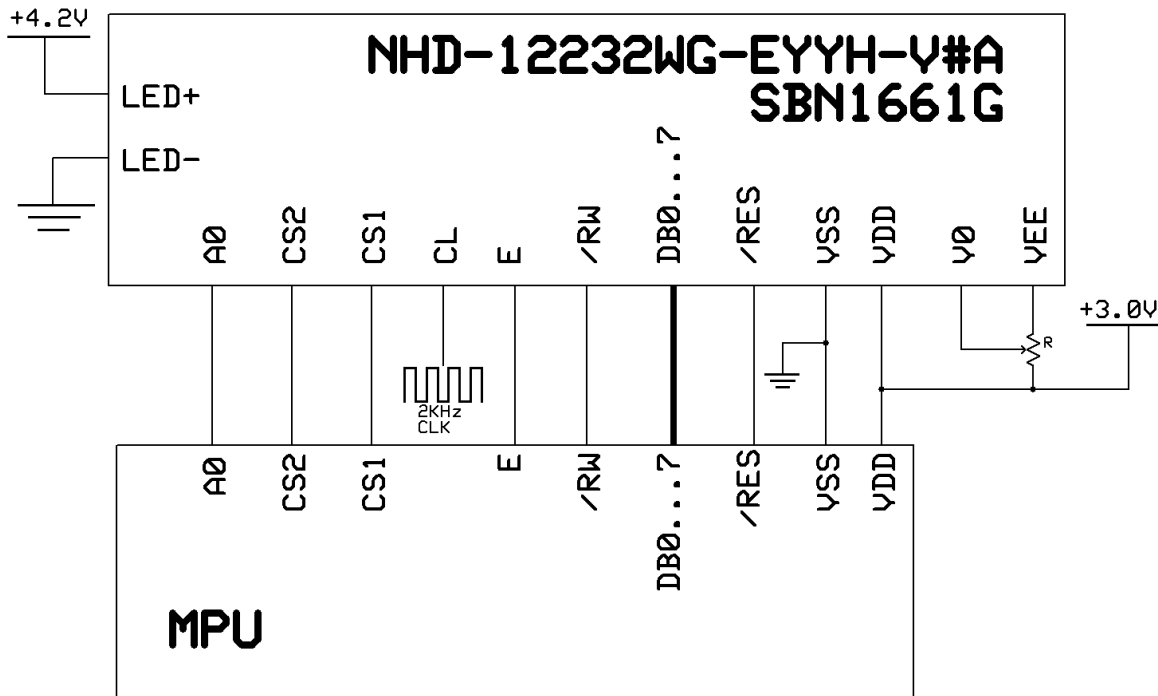

Electrical Characteristics

Item	Symbol	Condition	Min.	Typ.	Max.	Unit
Operating Temperature Range	Top	Absolute Max	-20	-	+70	°C
Storage Temperature Range	Tst	Absolute Max	-30	-	+80	°C
Supply Voltage	VDD	-	2.7	3.0	3.3	V
Supply Current	IDD	Ta=25°C, VDD=3.0V	-	5.0	-	mA
Supply for LCD (contrast)	VDD-V0	Ta=25°C	4.2	-	4.5	V
"H" Level input	VIH	-	2.0	-	VDD	V
"L" Level input	VIL	-	0	-	0.7	V
"H" Level output	VOH	-	VDD -0.3	-	VDD	V
"L" Level output	VOL	-	0	-	0.3	V
Backlight Supply Voltage	VLED	-	4.0	4.2	4.5	V
Backlight Supply Current	ILED	VLED=4.2V	96	120	144	mA
Backlight Lifetime	-	ILED ≤ 120mA	-	100,000	-	Hrs.

Optical Characteristics

Item	Symbol	Condition	Min.	Typ.	Max.	Unit
Optimal Viewing Angles	Top	Cr ≥ 2	-	20	-	°
	Bottom		-	40	-	°
	Left		-	30	-	°
	Right		-	30	-	°
Contrast Ratio	Cr	-	-	3	-	-
Response Time	Rise	Tr	-	150	200	ms
	Fall	Tf	-	150	200	ms

Controller Information

Built-in SBN1661G_M02 controller.

Please download specification at http://www.newhavendisplay.com/app_notes/SBN1661G.pdf

Timing Characteristics

AC timing for interface with a 68-type microcontroller

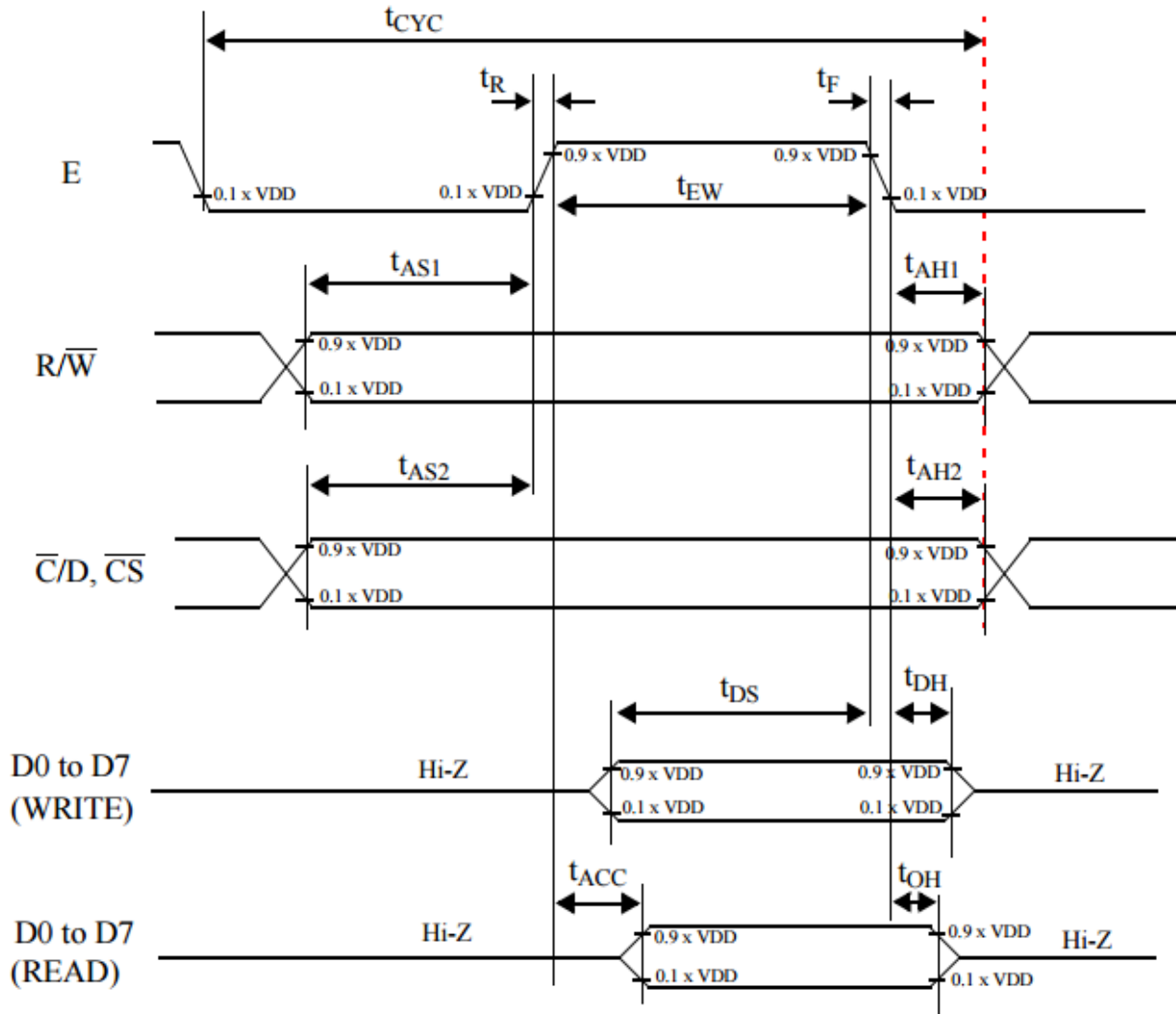

symbol	parameter	min.	max.	test conditons	unit
t_{AS1}	Address set-up time with respect to R/\bar{W}	20			ns
t_{AS2}	Address set-up time with respect to $\bar{C}/D, \bar{CS}$	20			ns
t_{AH1}	Address hold time with respect to R/\bar{W}	10			ns
t_{AH2}	Address hold time respect with to $\bar{C}/D, \bar{CS}$	10			ns
t_F, t_R	Enable (E) pulse falling/rising time		15		ns
t_{CYC}	System cycle time	1000		Note 1	ns
t_{EWR}	Enable pulse width for READ	100			ns
t_{EWW}	Enable pulse width for WRITE	80			ns
t_{DS}	Data setup time	80			ns
t_{DH}	Data hold time	10			ns
t_{ACC}	Data access time		90	CL= 100 pF.	ns
t_{OH}	Data output hold time	10	60	Refer to Fig. 23.	ns

AC timing for interface with an 80-type microcontroller

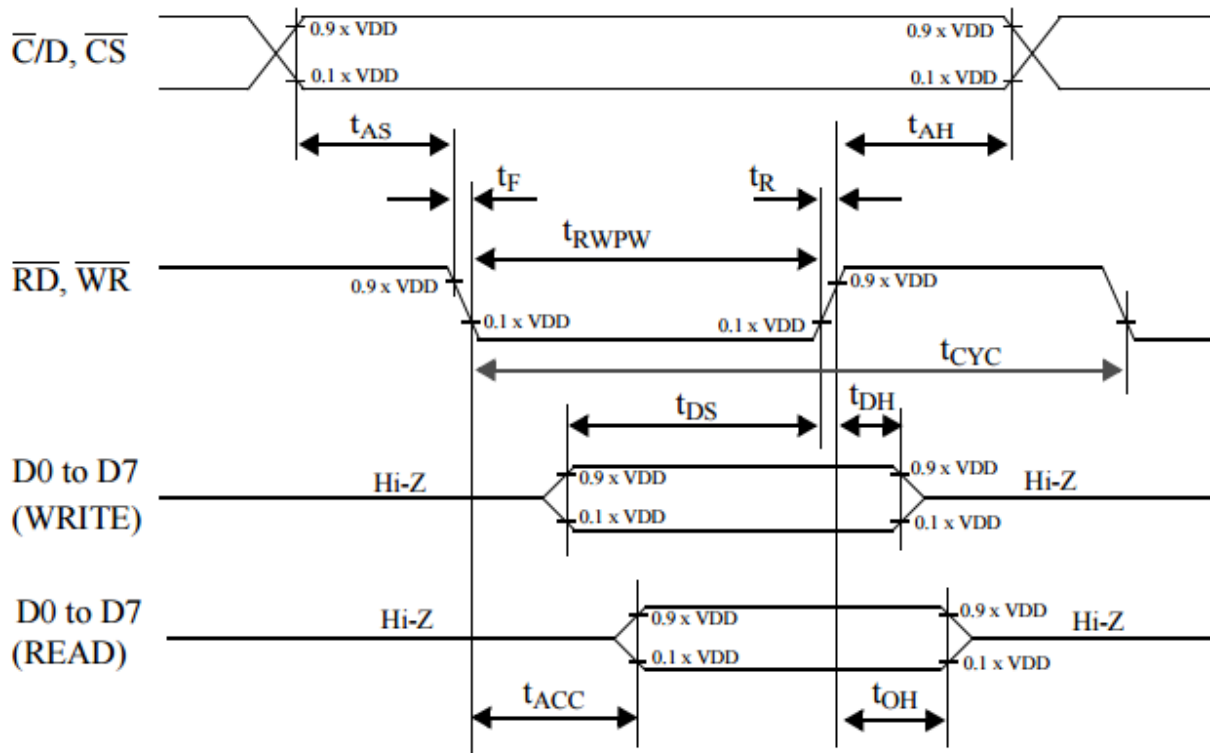

symbol	parameter	min.	max.	test conditons	unit
t_{AS}	Address set-up time	20			ns
t_{AH}	Address hold time	10			ns
t_F, t_R	Read/Write pulse falling/rising time		15		ns
t_{RWPW}	Read/Write pulse width	200			ns
t_{CYC}	System cycle time	1000			ns
t_{DS}	Data setup time	80			ns
t_{DH}	Data hold time	10			ns
t_{ACC}	Data READ access time		90	CL= 100 pF.	ns
t_{OH}	Data READ output hold time	10	60	Refer to Fig. 23.	ns

Table of Commands

COMMAND	COMMAND CODE								FUNCTION
	D7	D6	D5	D4	D3	D2	D1	D0	
Write Display Data	Data to be written into the Display Data Memory.								Write a byte of data to the Display Data Memory.
Read Display Data	Data read from the Display Data Memory.								Read a byte of data from the Display Data Memory.
Read-Modify-Write	1	1	1	0	0	0	0	0	Start Read-Modify-Write operation.
END	1	1	1	0	1	1	1	0	Stop Read-Modify-Write operation.
Software Reset	1	1	1	0	0	0	1	0	Software Reset.

Example Initialization Program:

```

/*****
void Comleft(char i)
{
  CS1 = 0;
  P1 = i;
  R_W = 0;
  D_I = 0;
  E1 = 1;
  delay(2);
  E1 = 0;
  CS1 = 1;
}

void Comright(char i)
{
  CS2 = 0;
  P1 = i;
  R_W = 0;
  D_I = 0;
  E2 = 1;
  delay(2);
  E2 = 0;
  CS2 = 1;
}

void Writeleft(char i)
{
  CS1 = 0;
  P1 = i;
  R_W = 0;
  D_I = 1;
  E1 = 1;
  delay(2);
  E1 = 0;
  CS1 = 1;
}

void Writeright(char i)
{
  CS2 = 0;
  P1 = i;
  R_W = 0;
  D_I = 1;
  E2 = 1;
  delay(2);
  E2 = 0;
  CS2 = 1;
}

```



```

/*****/
void bothSides(char i)
{
  Comleft(i);
  Comright(i);
}
/*****/

void init()
{
  P1 = 0;
  P3 = 0;
  CS1 = 0;
  CS2 = 0;
  RST = 0; //      Reset RST
  delay(1);
  RST = 1; //      Reset RST= M68 Interface
  delay(10);
  D_I = 0;
  E1 = 1;
  E2 = 1;
  R_W = 1;

  bothSides(0xE2);
  delay(10);
  bothSides(0xA4);
  bothSides(0xA9);
  bothSides(0xA0);
  bothSides(0xEE);
  bothSides(0xC0);
  bothSides(0xAF);
}
/*****/

```

Quality Information

Test Item	Content of Test	Test Condition	Note
High Temperature storage	Endurance test applying the high storage temperature for a long time.	+80°C , 200hrs	2
Low Temperature storage	Endurance test applying the low storage temperature for a long time.	-30°C , 200hrs	1,2
High Temperature Operation	Endurance test applying the electric stress (voltage & current) and the high thermal stress for a long time.	+70°C 200hrs	2
Low Temperature Operation	Endurance test applying the electric stress (voltage & current) and the low thermal stress for a long time.	-20°C , 200hrs	1,2
High Temperature / Humidity Operation	Endurance test applying the electric stress (voltage & current) and the high thermal with high humidity stress for a long time.	+60°C , 90% RH , 96hrs	1,2
Thermal Shock resistance	Endurance test applying the electric stress (voltage & current) during a cycle of low and high thermal stress.	-20°C,30min -> 25°C,5min -> 70°C,30min = 1 cycle 10 cycles	
Vibration test	Endurance test applying vibration to simulate transportation and use.	10-55Hz, 1.5mm amplitude. 60 sec in each of 3 directions X,Y,Z For 15 minutes	3
Static electricity test	Endurance test applying electric static discharge.	VS=600V, RS=330Ω, CS=150pF 10 times	

Note 1: No condensation to be observed.

Note 2: Conducted after 4 hours of storage at 25°C, 0%RH.

Note 3: Test performed on product itself, not inside a container.

Precautions for using LCDs/LCMs

See Precautions at www.newhavendisplay.com/specs/precautions.pdf

Warranty Information and Terms & Conditions

http://www.newhavendisplay.com/index.php?main_page=terms