

DCmind Brushless motor Datasheet

80 370 001
SMI22 with CAN

Series
80 370 SMI22 CAN

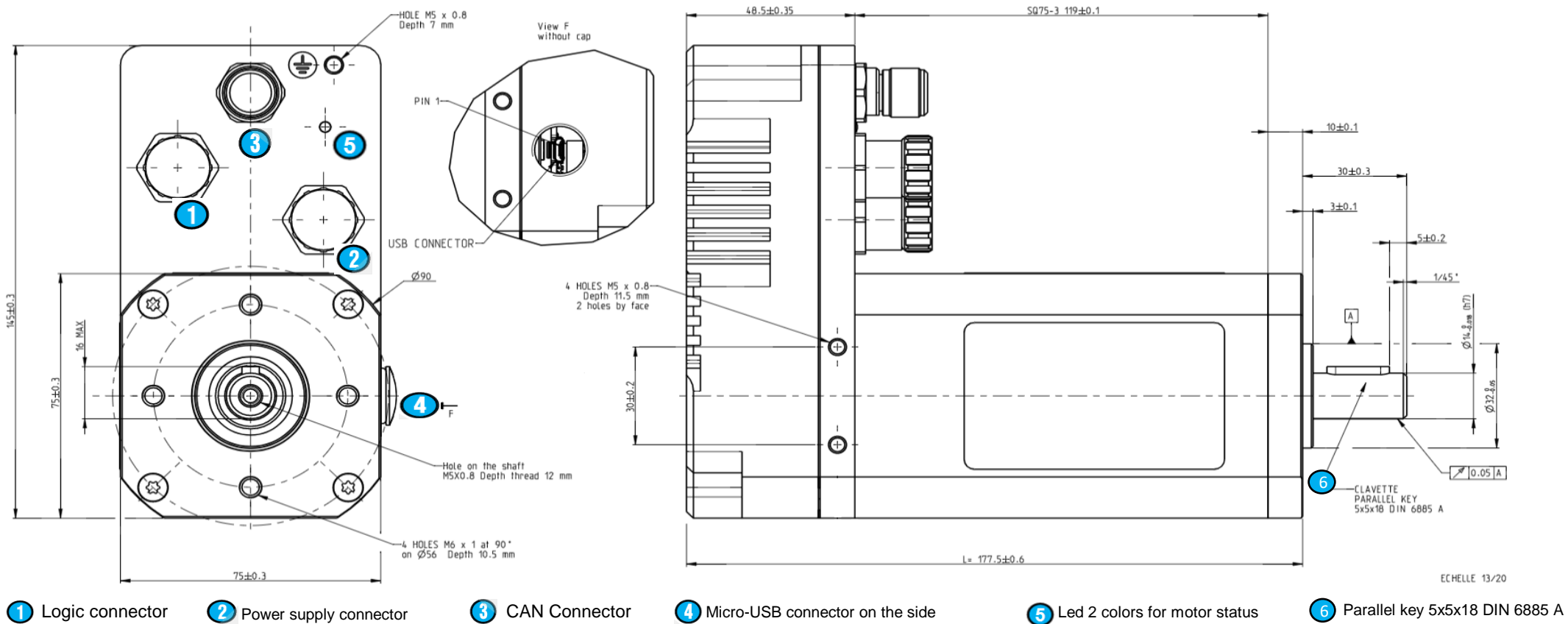

General characteristics

Power supply		
Direct current voltage supply		✓
Nominal voltage range	Vdc	9 -> 75
Max. current	A	75

Motor characteristics (1)		32 Vdc	48 Vdc	60 Vdc	
At no load					
Max. output speed	rpm	2 300	3 420	4 320	
Current at the max output speed	A	1	1	1	
Standby current	mA	50	50	50	+/-10%
At nominal					
Speed	rpm	2 000	3 130	3 890	+/-10%
Torque	N.m	1,9	1,9	1,9	
Output power	W	398	623	700	+/-10%
Current	A	15,1	15,1	15,1	
Efficiency	%	80	86	78	
At max. output power					
Speed	rpm	1 650	2 340	3 170	
Torque (2)	N.m	5	6	6	
Output power	W	864	1 470	1 800	
Current	A	40	44	44	
Efficiency	%	67	70	68	
At peak torque					
Speed	rpm	1 650	2 340	3 170	
Torque	N.m	5	6	6	
Output power	W	864	1 470	1 800	
Current	A	44	44	44	

Others		
Life	h	20 000
Rotor inertia	gcm ²	763
Rotor poles		8
Cogging torque	mNm	75
Weight	kg	3,3
Noise level	dBA	55

Connecting		
Input/Output M16 connector - 18 pins	Pins N°	
Optional logic supply	1	
0 Volt	2	
Input 6 (analogic 1)	3	
Input 5 (analogic 2)	4	
Input 1 (digital)	5	
Input 2 (digital)	6	
Input 3 (digital)	7	
Input 4 (digital)	8	
0 Volt	9	
Output 1 (digital - PWM)	10	
Output 2 (digital - PWM)	11	
Output 3 (digital)	12	
Output 4 (digital)	13	
0 Volt	14	
STO2 -	15	
STO2 +	16	
STO1 -	17	
STO1 +	18	
Power supply M16 connector 3 pins	Pins N°	
Output ballast	1	
+VDC	2	
0 Volt	3	
CAN M 12 Connector - 5 pins	Pins N°	
Not connected	1 / 2	
CAN_GND	3	
CAN_H	4	
CAN_L	5	

Drive		
Type		SMI22 CAN
Built-in drive		✓
Internal magnetic encoder		4096 pulses/rev
Setting software on PC		DCmind soft+CANopen
Control		
Position - speed - torque		✓
4 quadrants		✓
With regenerative energy absorber (3)		✓
Type "Field Oriented Control"		✓
Security		
Wrong polarity from power supply		✓
Output shortcut		✓
Input inverted		✓
Low voltage	Vdc	< 9
Overvoltage (4)	Vdc	> 75
Internal drive temperature protection	°C	110
Temperature drive allowing to restart	°C	90

Generic parameters		
Output shaft with ball bearings		✓
2 Safe Torque Off inputs IEC61800-5-2/62061, ISO13849		✓
Max. Radial force (16mm from front face)	N	140
Max. axial force	N	47
Temperature range	CEI60068-2-1/2	°C -30 -> +70
Storage temperature		°C -40 -> +80
Dielectric (1s/2mA)	UL1004-1	Vdc ###
Motor insulation	CEI60085	class E
Salt spray	ISO9227	severity 48h
Degree of protection (output shaft not included)	CEI60529	IP67 + IP69

EMC		
Electrostatic Discharge	CEI61000-4-2	level 3
Radiated field	CEI61000-4-3	level 3
Electrical fast transient / burst test	CEI61000-4-4	level 3
Surge test	CEI61000-4-5	level 1
Conducted disturbances	CEI61000-4-6	level 3
Radiated emission	EN55022	class B

Approvals		
ROHS	2011/65/CE	✓
EC		✓
UL		IN PROGRESS
CAN Open	CIA 301 - DSP 402	✓
Communication		
USB (Setting, monitoring)		Micro-USB B
CAN open: adress - node ID (factory settings)		0x20
CAN open: baud rate (factory settings)		kbaud 1000

Notes	
Values without tolerances, are average production values.	
(1) Cold motor, 20 ° C ambient temperature, full speed, sinusoidal commutation	
(2) Max torque for continuous operation at 20 °C, decrease this value for higher ambient temperature	
(4) Can be configured via Dc mind soft+CANopen	
(5) Ballast resistor to be added	

Additional information is available in the SQ75 product user manual and in the starter kit manual, available in www.crouzet.com

Specifications subject to change without notice. Updated November 28, 2018

Drive electrical data

Running datas				
Parameters		Min.	Typical	Max.
Voltage supply "Vdc"	Vdc	9	48	75
Current "Idc"	A	-	15	60
Standby power "Wo"	W	-	2	-
Optional logic voltage (see wiring diagram)	Vdc	9	-	75

CAN Bus characteristics				
Parameters		Min.	Typical	Max.
CAN_L insulated	Vdc	0,5	1,5	2,25
CAN_H insulated	Vdc	2,75	3,5	4,5

Accessories

Starter kit				
Part number	79 513 105			
Power/logic/CAN 3 m cables - Software - USB to Can Open adapter - CAN terminal resistor - CAN double connector				
Power supply cable	79 298 664	3m length	AWG18	
Input-Output cable	79 513 106	3m length	AWG24	
CAN cable M12	27 358 015	1m length	AWG26	

Input datas					
Parameters		Min.	Typical	Max.	
Input 1, 2, 3, 4	Impedance	kΩ	-	200	-
	Low level	Vdc	-90	-	2,4
	High level	Vdc	5	-	90
Input 5, 6	Impedance	kΩ	-	107,2	-
	Low level	Vdc	-90	-	2
	High level	Vdc	7	-	90
Inputs STO	Low level	Vdc	-2	-	4
	High level	Vdc	5	-	75

Output datas				
Parameters		Min.	Typical	Max.
Low level Output 1, 2, 3, 4	mVdc	-	-	10
High level Output 1, 2, 3, 4	Vdc	-	4,75	-
Max output current "I outmax"	mA	-	-	50
I sink	mA	-	-	600

Speed-torque and current-torque curves

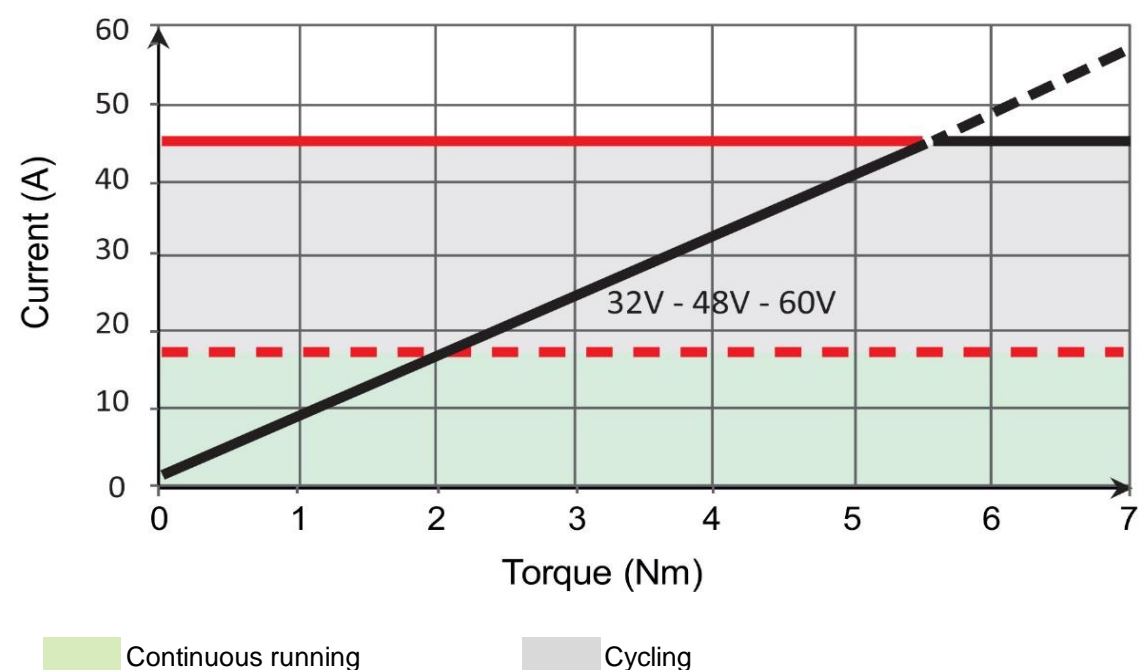
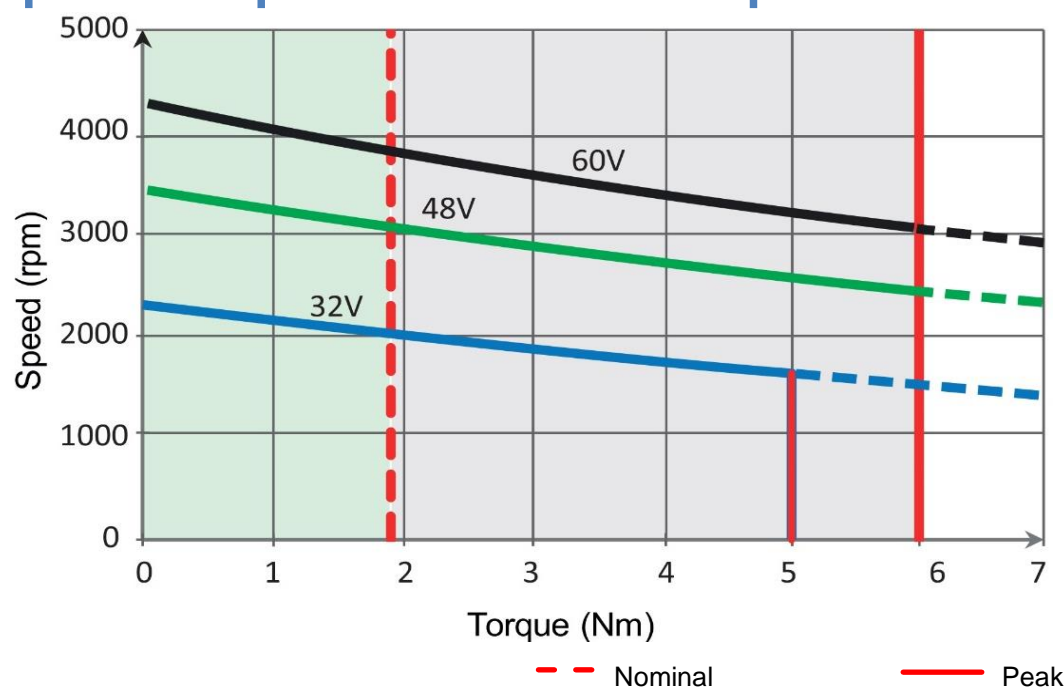

Wiring

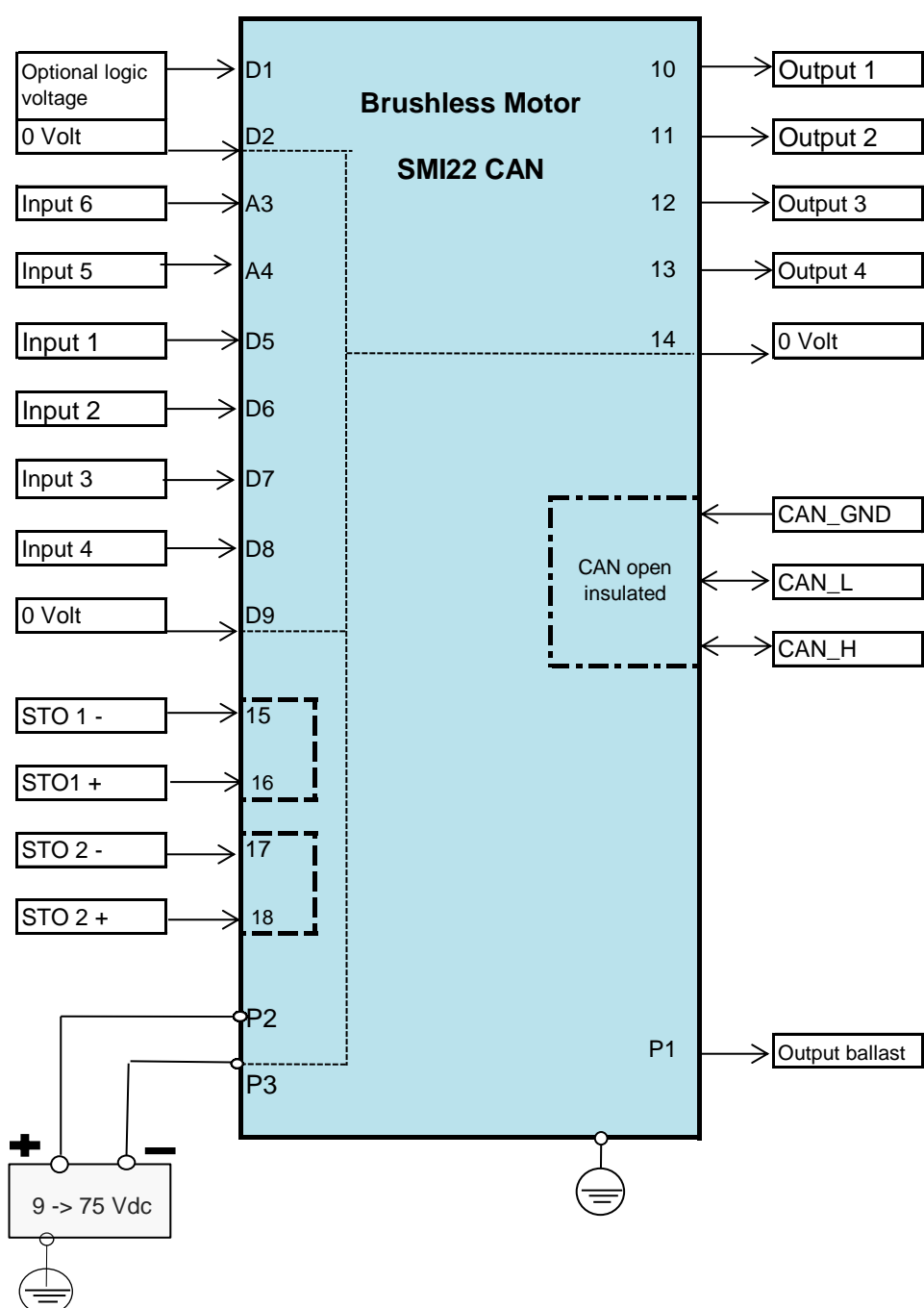

Input equivalent circuit

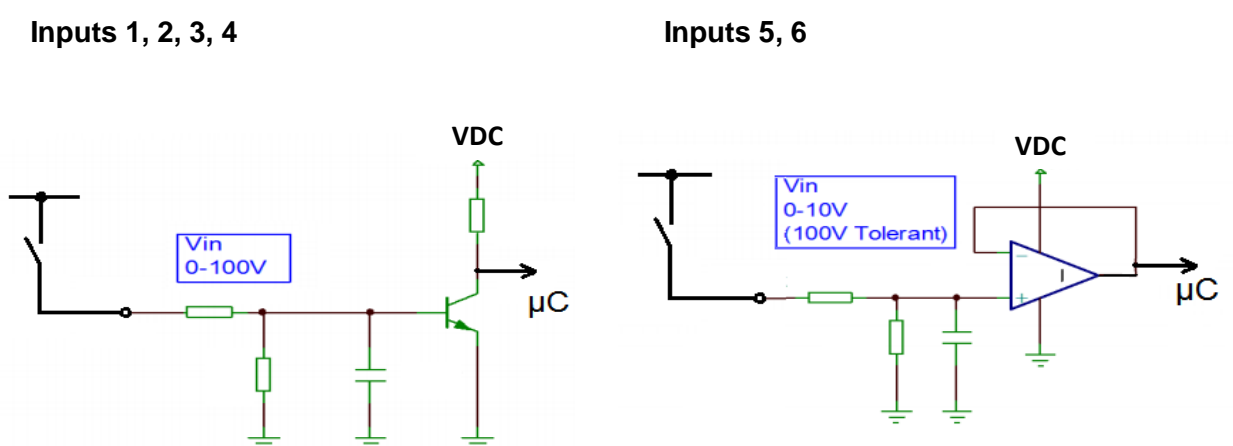

Output equivalent circuit

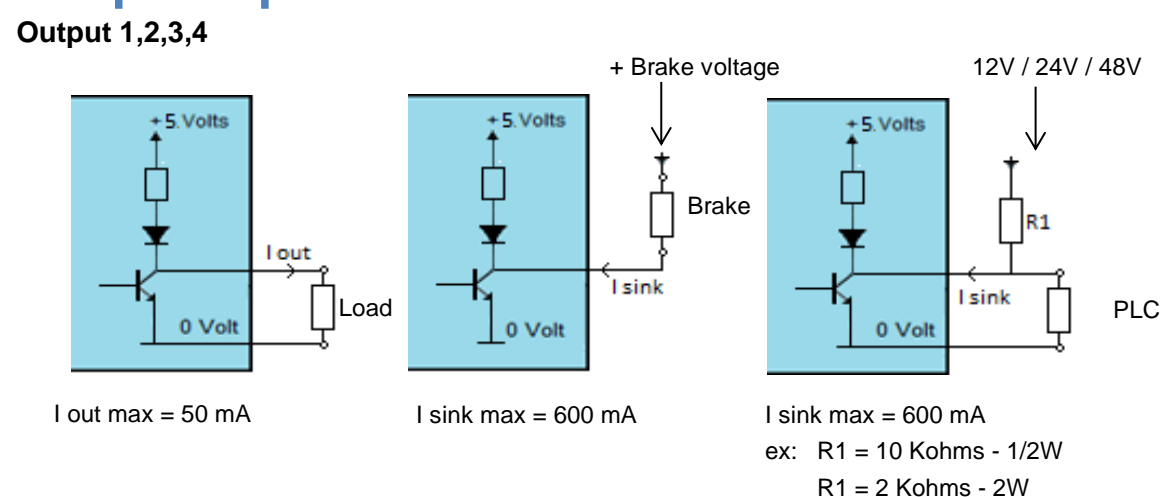

Output ballast

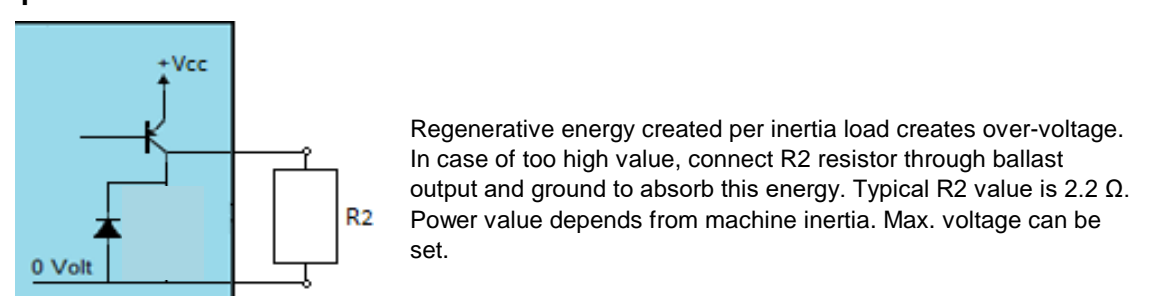

Specifications subject to change without notice. Updated November 28, 2018

Crouzet Automatismes

12, rue Jean Jullien-Davin - CS 60059
26902 Valence CEDEX 9 France

www.crouzet.com

Series 80 370 SMI22 CAN