

FABCO-AIR

Pancake[®] II Air Cylinders

*Superior Interchangeable
Industrial Air Cylinders*

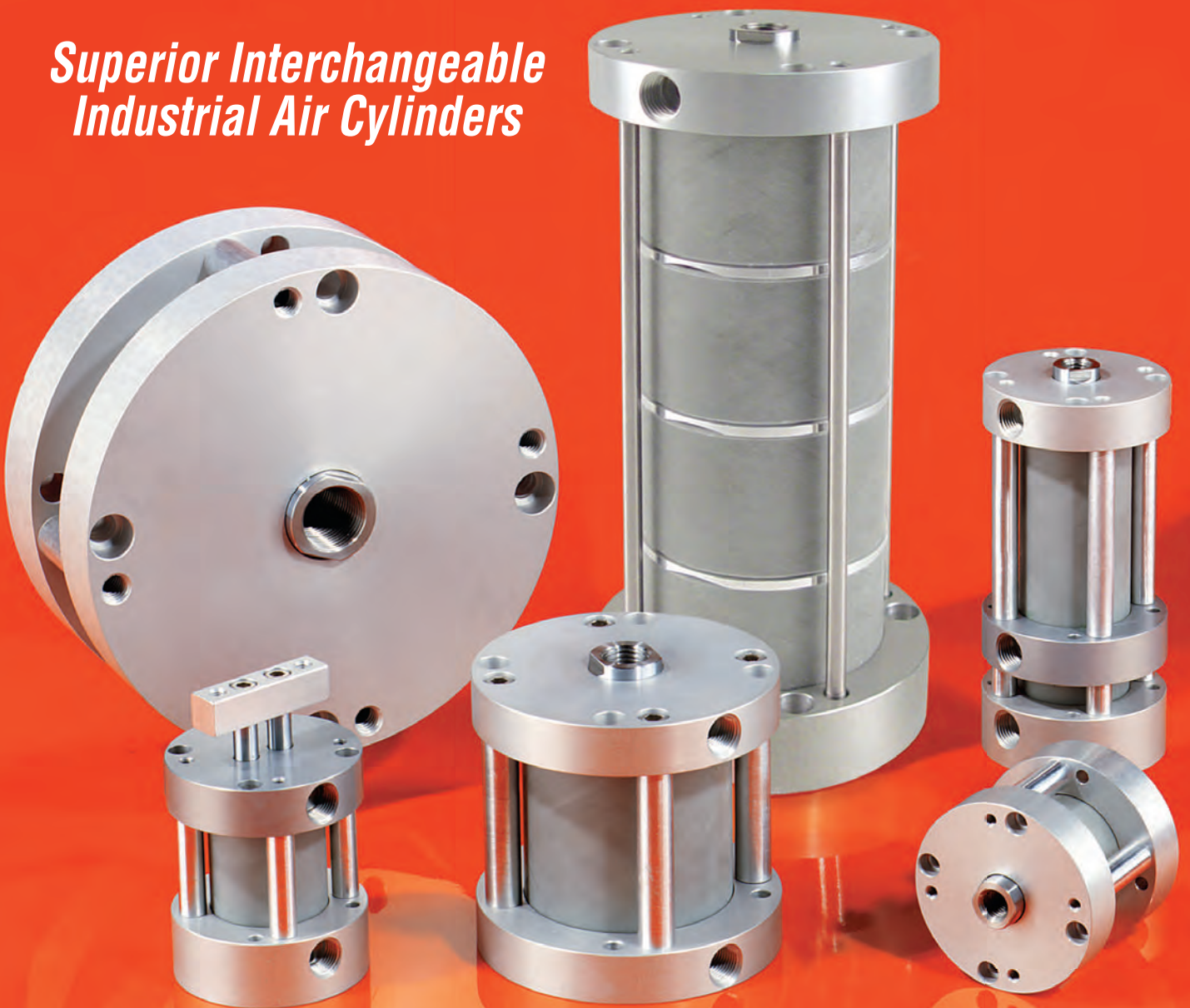

FABCO-AIR Pancake® II Cylinders

Product Index



Standard Series PSD, PSR, PSX, PWD, PTD

How it works	3
How to Order	5
Dimensions	6 - 9
Options	8, 9
Weights	7
Repair kits	9

Nonrotating , Twin Rod Series PND

How it works	10
How to Order	11
Dimensions	12, 13
Options	12, 13
Weights	13
Repair kits	13

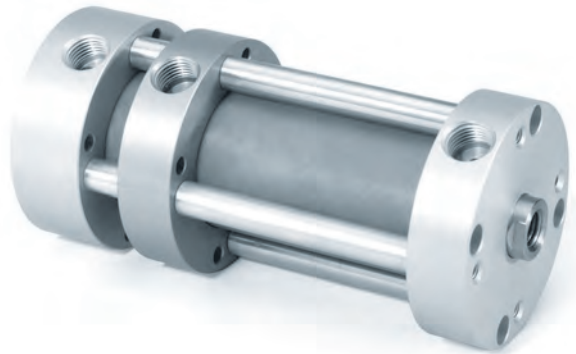
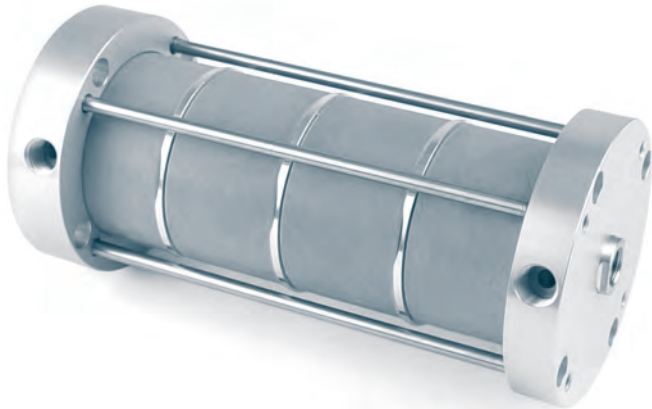

Multi-Power® Series PA and PB

How it works	14
How to Order	15
Dimensions	16, 17
Options	17
Weights	17
Repair kits	17

3-Position Series P3D

How it works	18
How to Order	19
Dimensions	20, 21
Options	20, 21
Weights	21
Repair kits	21

Magnetic Position Sensing

Sensors	23
Quick disconnect cordsets	23

Accessories

All Series	22
----------------------	----

The Pancake® II Direct Interchange Air Cylinders

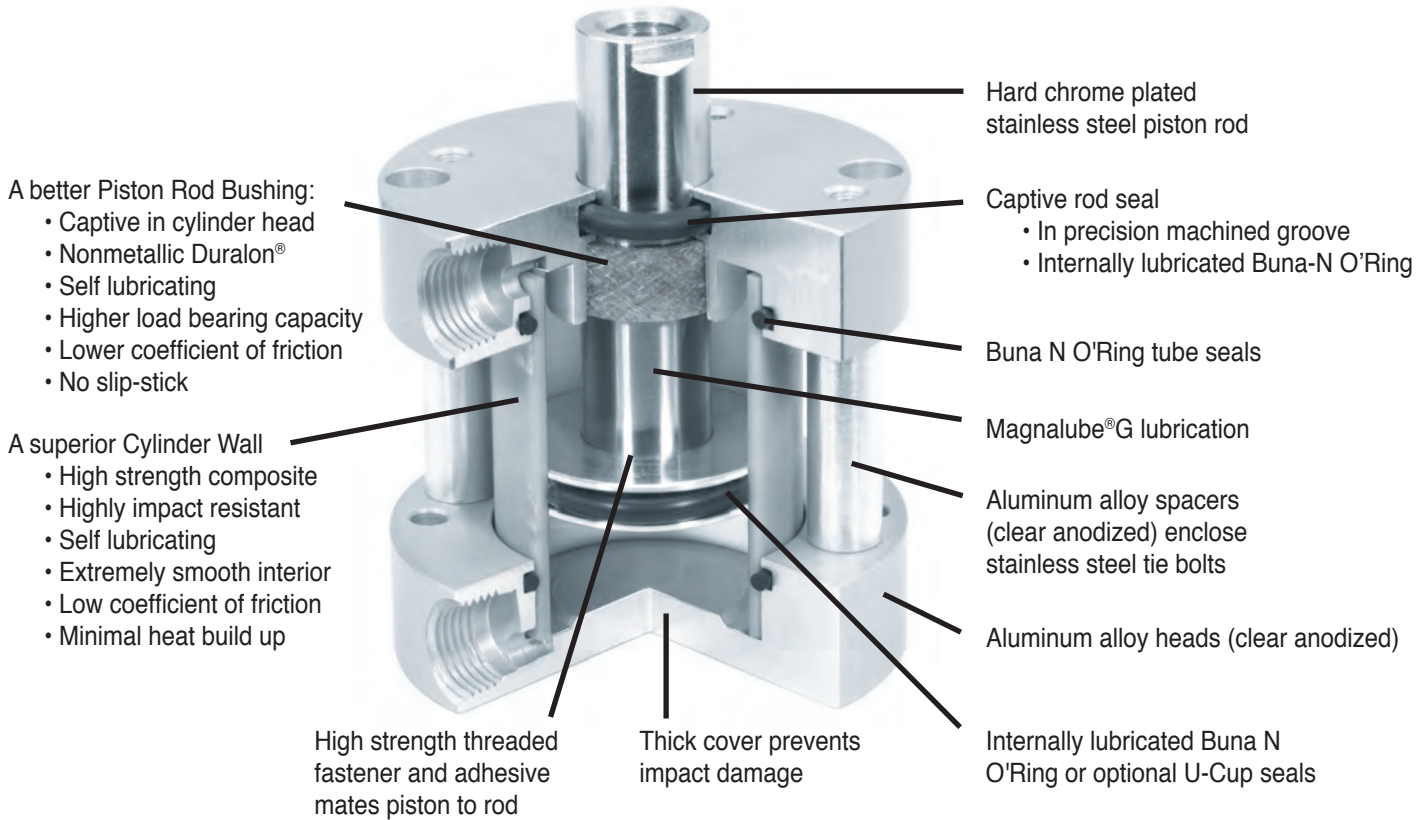

Superior Interchangeable Industrial Air Cylinders

Innovation – For over 40 years our famous Pancakes® have dominated as the world's first compact air cylinder line. Today, backed by decades of engineering and manufacturing innovation, our new **Pancake® II** composite body air cylinders continue in the Pancake® tradition with a wide selection of models and options.

Packed with value – Stainless steel tie bolts and aluminum spacers lock precision machined heads tightly around a unique, high strength, composite cylinder barrel. The barrel's extremely smooth, self-lubricating interior surface insures highly reliable performance and extended seal life. Its high impact resistance reduces chances of cylinder failure due to dings or dents. Zero slip-stick avoids problems that metal cylinders encounter when they sit in a static condition for extended periods of time. Combined with hard chrome plated stainless steel piston rods and a unique, nonmetallic rod bearing, the new Fabco-Air cylinder assembly assures optimal operation and longer product life.

Exceptional Piston Rod Bearing – The better the bearing, the more cycle life you can expect from your air cylinders. **Pancake® II** cylinders incorporate a truly superior rod

Duralon® Rod Bearings Excel

Machine Design 1972/73	Load Capacity (psi)	Friction Properties	Coefficient	Slip-stick
Bearing Reference Issue				
Porous Bronze	4,500	Steel-on-steel	.50	Yes
Porous iron	8,000	Bronze-on-steel	.35	Yes
Phenolics	6,000	Sintered Bronze-on-steel		
Nylon®	1,000	with mineral oil	.13	No
TFE	500	Bronze-on-steel		
Reinforced Telfon®	2,500	with mineral oil	.16	No
*TFE fabric	60,000	Copper lead alloy-on-steel	.22	Yes
Polycarbonate	1,000	Acetal-on-steel	.20	No
Acetal	1,000	Nylon-on-steel	.32	Yes
Carbon-graphite	600	Duralon-on-steel	.05 - .16	No

* Shows Duralon bearing classification. Not to be used for design purposes.

Printed with permission by Rexnord Corp.

bearing material - Duralon® with the same field-proven performance you have come to expect from the six other Fabco-Air cylinder families.

Duralon® is a composite of a Teflon®/Dacron® fabric liner bonded to a supporting filament-wound, high strength, fiberglass and epoxy resin shell. Resistant to corrosion, moisture and temperature to 325°F, the bearing is reliable in any environment. It has an extremely high load bearing capacity, very low friction, and will not gall or score the piston rod (see physical properties in the table above).

FABCO-AIR Pancake® II Cylinders



Available in 5 styles
8 Bore sizes 1/2" thru 4"
Strokes to 4" standard

- Double acting, single rod
- Double acting, double rod
- Double acting, hole thru double rod
- Single acting, spring retracted rod
- Reverse acting, spring extended rod

Ratings – Standard Units all Series

• Body	Self-lubricating composite	• Stroke tolerance	± 1/64"
• Heads.....	Clear anodized aluminum alloy	• Media	Air
• Tie Bolts	Stainless steel	• Pressure rating, maximum	200 psi
• Rod.....	Chrome plated stainless steel	• Minimum recommended	
• Piston	Aluminum alloy	operating pressure	15 psi
• Rod end.....	Female thread with wrench flats	• Temperature rating	
• Ports	Position #1	Cylinder	-25° to +221°F (-32° to +105°C)
• Seals	Internally lubricated Buna-N	• Temperature rating	
• Lubrication.....	Magnalube®-G	Electronic sensors	-4° to +176°F (-20° to +80°C)
• Rod bushing	PTFE composite bearing		

Approximate Spring Forces

Bore	Maximum Force (lbs)	Spring Rate (lbs/inch) for Stroke Range			
		0.12 to 1" Stroke	1.001 to 2" Stroke	2.001 to 3" Stroke	3.001 to 4" Stroke
1/2 (1)	5.25	4.25	2.13	1.42	1.06
3/4 (2)	10.00	6.00	3.00	2.00	1.50
1-1/16 (3)	13.00	6.50	3.25	2.17	1.63
1-1/2 (4)	13.00	6.50	3.25	2.17	1.63
2 (5)	13.00	6.50	3.25	2.17	1.63
2-1/2 (6)	25.00	12.50	6.25	4.17	3.13
3 (7)	25.00	12.50	6.25	4.17	3.13
4 (8)	25.00	12.50	6.25	4.17	3.13

Cylinder Sizing Guide

Bore Diameter (inch)	1/2	3/4	1-1/16	1-1/2	2	2 1/2	3	4
Rod Diameter (inch)	0.25	0.31	0.50	0.63	0.75	0.75	0.88	1.00
Rod Area (in ²)	0.05	0.08	0.19	0.31	0.44	0.44	0.60	0.79
Push Area (Single Rod) (in ²)	0.20	0.44	0.88	1.76	3.14	4.91	7.07	12.57
Push Area (Double Rod) (in ²)	0.15	0.36	0.69	1.45	2.66	4.47	6.47	11.78
Pull Area (in ²)	0.15	0.36	0.69	1.45	2.66	4.47	6.47	11.78

Please visit <http://portal.fabco-air.com/configure.php> for current pricing.
 Specifications and prices subject to change without notice or incurring obligation

How to Order

Series P - Pancake® II	Action D - double acting R - single acting, spring retract (Model S only) X - single acting, spring extend (Model S only)	Bore 1 - 1/2" 2 - 3/4" 3 - 1-1/16" 4 - 1-1/2" 5 - 2" 6 - 2-1/2" 7 - 3" 8 - 4"	Stroke 0.125 - 1/8" 0.250 - 1/4" 0.375 - 3/8" 0.500 - 1/2" etc., thru 4.000 - 4" (see pages 6 & 7 for standard strokes)	Note: Special strokes are available on request. Contact Engineering or your local Fabco-Air Distributor.
-----------------------------------------	----------------------------------------------------------------------------------------------------------------------------------------------------------------	----------------------------------------------------------------------------------------------------------------------------------------------------------------------	----------------------------------------------------------------------------------------------------------------------------------------------------------------------------------------	-------------------------------------------------------------------------------------------------------------

Model Number **Series** **Model** **Action** **Bore** - **Mounting** **Stroke** - **Options**

Mounting

Leave blank for standard counterbored mounting holes (see page 6) in the basic model. For other mounting specify only one option code.

- CB - Screw head clearance holes, both ends¹
- CF - Screw head clearance holes, front¹
- CR - Screw head clearance holes, rear¹
- F - Nose mount (all except double rod models)²
- HB - Threaded mounting holes, both ends
- HF - Threaded mounting holes, front
- HR - Threaded mounting holes, rear
- PM - Pivot mount, pin 90° from port
- SM - Pivot mount, pin in-line with port
- TB - Trunnion mount, both ends³
- TF - Trunnion mount, front³
- TR - Trunnion mount, rear³

¹ "Screw head clearance" to allow bolt head to pass through; No counter bores (see page 8)
² Includes heavy duty rear head and rod wiper
³ Not available in 1/2" bore.

How to Order

1. Specify **P**, Model, Action, and Bore
2. Specify optional Mounting (if required), then Stroke
3. Specify the Options in alphabetical order

Ordering example #1: **PTD4-HF2.500-TCFV**

Pancake® II with double rod hole thru, double acting, 1-1/2" bore, front threaded mounting holes, 2-1/2" stroke, coarse female rod thread, and Viton seals.

Ordering example #2: **PSD3-1.000**

Pancake® II with single rod, double acting, 1-1/16" bore, standard counterbored mounting holes and 1" stroke.

Options *Enter in alphabetical order*

- B - Bumpers, both ends¹
- BF - Bumper, front only¹
- BR - Bumper, rear only¹
- E - Magnet on piston for position sensing (see length adders page 9) 3/8" stroke minimum²
- H - Heavy duty rear head (see length adder page 9)
- J - Failsafe operation (single acting, spring retract models)³
- L - Low friction seals (see length adders page 9)
- M, M1, M3, M4 - Magnet on piston and adhesive mounted dovetail extrusion to hold 1/4" dovetail sensors. (see sensors page 23; length adders page 9) 3/8" stroke min.²
- P2, P3, P4 - Front port position other than standard⁴
- Q - Low temperature operation (-40°F to +200°F)
- TCF - Coarse female rod thread, dimension E (page 7)
- TCM - Male rod end with coarse thread (page 8)
- TFM - Male rod end with fine thread (page 8)
- TN - Non-threaded rod
- T1, T3, T4 - Additional adhesive mounted dovetail extrusions located in position 1, 3, or 4
- V - Viton seals for media compatibility (-15°F to +221°F)
- W - Rod wiper, Buna N only (page 8)
- X - **EXTRA** rod extension
 Example: X0.5 = 1/2" **EXTRA** Rod Extension
 X1 = 1" **EXTRA** Rod Extension

¹ Stroke is reduced by .03 per end; .06 for option B; Spring retracted, BR only; Spring extended, BF only.
² Not available with Viton seals or low temperature seals.
³ Not available in 1/2" bore.
⁴ P2 and P4 not available in 1/2" bore.

FABCO-AIR Pancake® II Cylinders

Model PSD Double Acting, Single Rod

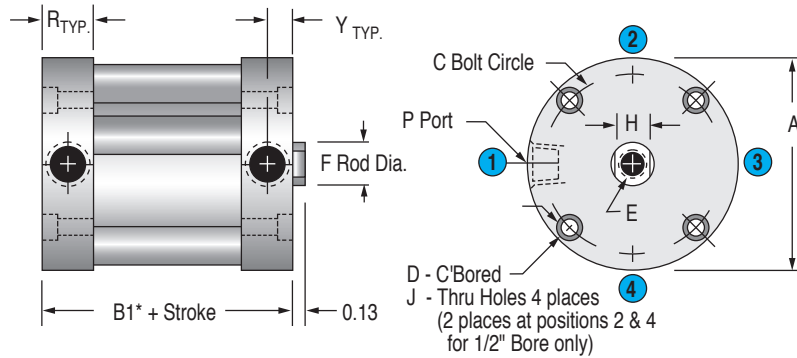

***Note: Some options effect cylinder length**

Standard Strokes – All Models: • 1/8 • 1/4 • 3/8 • 1/2 • 5/8 • 3/4 • 7/8 • 1 • 1-1/4 • 1-1/2 • 1-3/4 • 2 • 2-1/2 • 3 • 3-1/2 • 4
Special strokes available on request. Contact Engineering or your local Fabco-Air Distributor

Model PWD Double Acting, Double Rod Model PTD Double Acting, Hole Thru Double Rod

Hole Thru Diameter (PTD)		
Bore	Female Rod Thread	Male Rod Thread
1/2 (1)	0.14	N/A
3/4 (2)	0.14	0.09
1-1/16 (3)	0.22	0.16
1-1/2 (4)	0.28	0.19
2 (5)	0.38	0.25
2-1/2 (6)	0.38	0.25
3 (7)	0.44	0.31
4 (8)	0.50	0.38

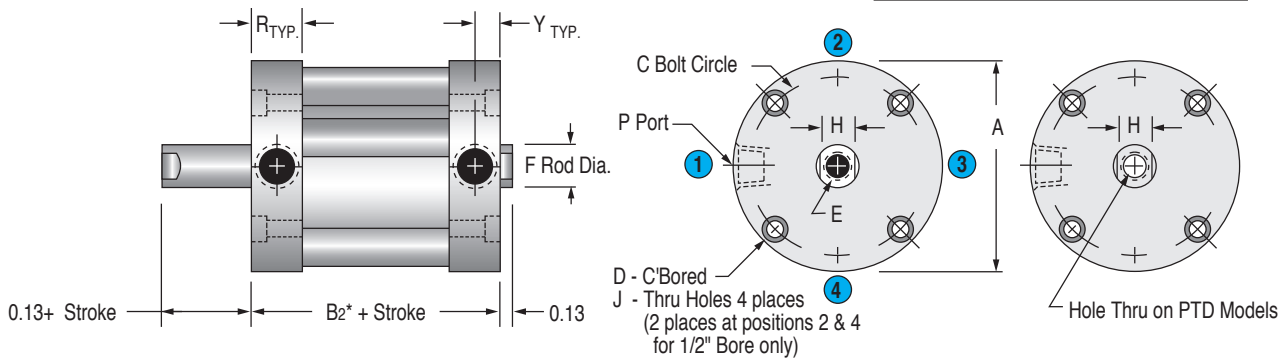

***Note: Some options effect cylinder length**

Dimensions (inches)

Bore	A	B1*	B2*	B3* for Stroke Range				B4* for Stroke Range				C	D C'Bore
				0-1	1.001-2	2.001-3	3.001-4	0-1	1.001-2	2.001-3	3.001-4		
				1/2 (1)	1.12	0.56	0.69	0.81	1.38	1.96	2.52		
3/4 (2)	1.49	0.56	0.69	0.81	1.38	1.94	2.50	1.06	1.62	2.19	2.75	1.22	0.24 x 0.15 dp
1-1/16 (3)	1.99	0.88	0.94	0.88	1.50	2.13	2.75	1.38	2.00	2.63	3.25	1.69	0.24 x 0.15 dp
1-1/2 (4)	2.62	0.88	1.00	0.88	1.50	2.13	2.75	1.38	2.00	2.63	3.25	2.19	0.34 x 0.22 dp
2 (5)	3.12	0.94	1.06	0.94	1.56	2.19	2.81	1.44	2.06	2.69	NA	2.69	0.34 x 0.22 dp
2-1/2 (6)	3.75	1.19	1.31	1.19	2.06	2.94	3.81	1.94	2.81	2.81	NA	3.25	0.40 x 0.27 dp
3 (7)	4.25	1.25	1.38	1.25	2.12	3.00	3.88	2.00	2.88	2.88	NA	3.78	0.40 x 0.27 dp
4 (8)	5.50	1.56	1.69	1.56	2.44	3.31	4.19	2.31	3.19	3.19	NA	4.94	0.49 x 0.33 dp

Standard Series PSD, PSR, PSX, PWD, PTD Basic Dimensions

Model PSR Single Acting, Spring Retract

See table on page 4
for spring forces

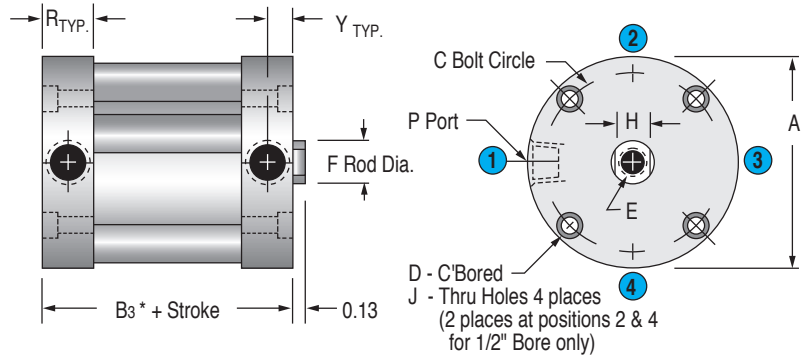

*Note: Some options effect cylinder length

Standard Strokes – All Models: • 1/8 • 1/4 • 3/8 • 1/2 • 5/8 • 3/4 • 7/8 • 1 • 1-1/4 • 1-1/2 • 1-3/4 • 2 • 2-1/2 • 3 • 3-1/2 • 4
Special strokes available on request. Contact Engineering or your local Fabco-Air Distributor

Model PSX Reverse Acting, Spring Extend

See table on page 4
for spring forces

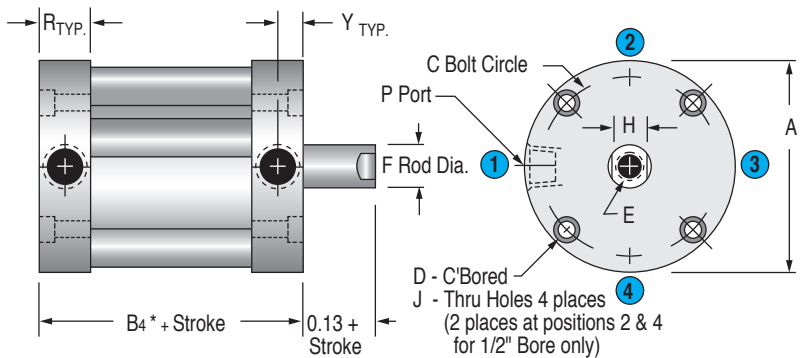

*Note: Some options effect cylinder length

Approximate Cylinder Weights (ounces) PSD, PSR, PWD, PTD, PSX

Bore	PSD, PSR		PWD, PTD		PSX		Nose Mount Option	
	Base	Adder per 1/8 of Stroke	Base	Adder per 1/8 of Stroke Model PWD	Adder per 1/8 of Stroke for Model PTD	Base	Adder per 1/8 of Stroke	Adder to Base Weight
1/2 (1)	1.15	.06	1.26	.14	.08	1.25	.06	0.1
3/4 (2)	1.82	.08	2.03	.18	.13	1.92	.08	0.2
1-1/16 (3)	4.70	.24	5.61	.37	.25	5.09	.24	1.1
1-1/2 (4)	9.22	.32	10.84	.55	.42	10.08	.32	1.8
2 (5)	12.48	.40	14.71	.64	.50	13.44	.40	2.7
2-1/2 (6)	21.50	.48	27.10	.74	.59	24.00	.48	3.1
3 (7)	27.74	.64	36.78	1.01	.76	31.20	.64	3.5
4 (8)	53.47	.80	69.50	1.20	.92	59.33	.80	5.9

Dimensions (inches)

Bore	E Standard	E Coarse	E Depth for Stroke Range		F	H	J Hole	P Port	R	Y
			1/8 – 1/2	5/8 +						
1/2 (1)	#8-32 UNC	N/A	0.30-0.46	0.46	0.25	0.22	0.13	#10-32 UNF	0.34	0.14
3/4 (2)	#10-32 UNF	#10-24 UNC	0.30-0.46	0.46	0.31	0.25	0.15	#10-32 UNF	0.34	0.14
1-1/16 (3)	5/16-24 UNF	5/16-18 UNC	0.37-0.63	0.70	0.50	0.44	0.15	1/8 NPT	0.50	0.25
1-1/2 (4)	3/8-24 UNF	3/8-16 UNC	0.37-0.70	0.70	0.63	0.50	0.20	1/8 NPT	0.50	0.25
2 (5)	1/2-20 UNF	1/2-13 UNC	0.30-0.63	0.70	0.75	0.63	0.20	1/8 NPT	0.53	0.25
2-1/2 (6)	1/2-20 UNF	1/2-13 UNC	0.42-0.70	0.70	0.75	0.63	0.26	1/4 NPT	0.66	0.33
3 (7)	5/8-18 UNF	5/8-11 UNC	0.45-0.73	0.73	0.88	0.75	0.26	1/4 NPT	0.69	0.33
4 (8)	3/4-16 UNF	3/4-10 UNC	0.40-0.70	0.80	1.00	0.88	0.33	3/8 NPT	0.84	0.42

FABCO-AIR Pancake® II Cylinders

Model Options

Male Rod Ends
(Option TCM or TFM)

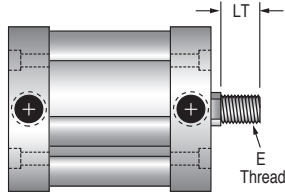

Thread Sizes			
Bore	E Thread		LT
	TCM (Coarse)	TFM (Fine)	
1/2 (1)	N/A	#8-32 UNC	0.38
3/4 (2)	#10-24 UNC	#10-32 UNF	0.38
1-1/16 (3)	5/16-18 UNC	5/16-24 UNF	0.50
1-1/2 (4)	3/8-16 UNC	3/8-24 UNF	0.50
2 (5)	1/2-13 UNC	1/2-20 UNF	0.63
2-1/2 (6)	1/2-13 UNC	1/2-20 UNF	0.63
3 (7)	5/8-11 UNC	5/8-18 UNF	0.75
4 (8)	3/4-10 UNC	3/4-16 UNF	0.75

Rod Wiper
(Option W)
Buna-N only

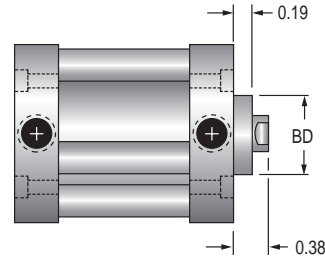

Boss Dia.	
Bore	BD
1/2 (1)	0.56
3/4 (2)	0.69
1-1/16 (3)	0.88
1-1/2 (4)	1.00
2 (5)	1.13
2-1/2 (6)	1.13
3 (7)	1.25
4 (8)	1.38

Mounting Options

Pivot Mount

Complete with bronze pivot bushing.
Not available as an accessory. (SM shown)

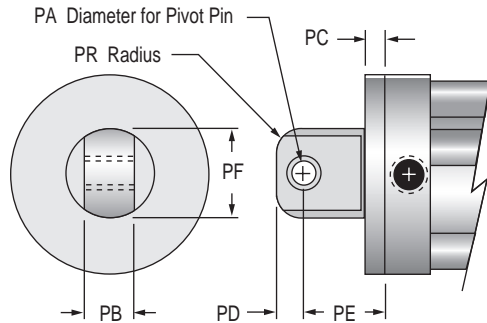

Screw Head Clearance Holes

Available either or both ends.
(CR shown)

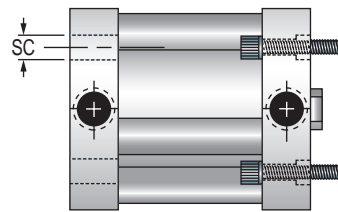

Trunnion Mount

Available rear, front or both.
Not available on 1/2" bore.
(TF shown solid)

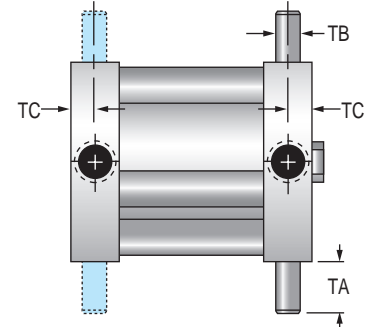

Dimensions (inches)											
Bore	PA	PB	PC	PD	PE	PF	PR	SC	TA	TB	TC
1/2 (1)	0.19	0.38	0.19	0.25	0.75	0.63	0.19	0.17	NA	NA	NA
3/4 (2)	0.19	0.38	0.19	0.25	0.75	0.75	0.19	0.23	0.31	0.125	0.17
1-1/16 (3)	0.19	0.38	0.25	0.25	0.81	0.75	0.19	0.25	0.50	0.250	0.25
1-1/2 (4)	0.38	0.75	0.25	0.44	1.19	1.38	0.38	0.34	0.50	0.250	0.25
2 (5)	0.38	0.75	0.31	0.44	1.25	1.38	0.38	0.34	0.50	0.250	0.25
2-1/2 (6)	0.38	0.75	0.38	0.44	1.31	1.38	0.38	0.41	0.63	0.312	0.33
3 (7)	0.63	1.00	0.38	0.56	1.69	1.88	0.38	0.41	0.63	0.312	0.33
4 (8)	0.63	1.00	0.44	0.56	1.75	1.88	0.38	0.50	0.75	0.375	0.42

Series PSD, PSR, PSX, PWD, PTD Option Dimensions

Seal Kits – Series PSD, PSR, PSX, PWD, PTD

Options	Kit Numbers by Bore Size							
	1/2"	3/4"	1-1/16"	1-1/2"	2"	2-1/2"	3"	4"
Standard	PS-1-SK	PS-2-SK	PS-3-SK	PS-4-SK	PS-5-SK	PS-6-SK	PS-7-SK	PS-8-SK
Viton (V)	PS-1-SKV	PS-2-SKV	PS-3-SKV	PS-4-SKV	PS-5-SKV	PS-6-SKV	PS-7-SKV	PS-8-SKV
Low Temperature (Q)	PS-1-SKQ	PS-2-SKQ	PS-3-SKQ	PS-4-SKQ	PS-5-SKQ	PS-6-SKQ	PS-7-SKQ	PS-8-SKQ
Low Friction (L)	PS-1-SKL	PS-2-SKL	PS-3-SKL	PS-4-SKL	PS-5-SKL	PS-6-SKL	PS-7-SKL	PS-8-SKL
Low Friction-Viton (L, V)	PS-1-SKLV	PS-2-SKLV	PS-3-SKLV	PS-4-SKLV	PS-5-SKLV	PS-6-SKLV	PS-7-SKLV	PS-8-SKLV
Low Friction-Low Temperature (L, Q)	PS-1-SKLQ	PS-2-SKLQ	PS-3-SKLQ	PS-4-SKLQ	PS-5-SKLQ	PS-6-SKLQ	PS-7-SKLQ	PS-8-SKLQ

Deviations from Standard Dimensions (Options L, H, E, M)

‡ Heavy duty rear head is recommended for applications where the cylinder is mounted on the front face or trunnion-mounted, and impact loading (20 or more cycles/minute) occurs between the piston and rear head. It increases the overall length of the cylinder as shown.

† A minimum stroke of 3/8" is required to sense end-of-stroke positions. For low friction seals used in conjunction with magnetic position sensing, use "E" or "M" length adder only.

Bore	Length Adder (inches)				
	Low Friction Seals (L)	Heavy Duty Rear Head† (H)	Magnetic Position Sensing† (E or M)		
			PSD, PWD, PTD	PSR	PSX
1/2 (1)	0.25	0.13	0.88	0.63	0.38
3/4 (2)	0.25	0.13	0.88	0.88	0.88
1-1/16 (3)	0.38	0.19	0.88	0.88	0.88
1-1/2 (4)	0.38	0.19	0.88	0.88	0.88
2 (5)	0.38	0.19	0.88	0.88	0.88
2-1/2 (6)	0.38	0.25	0.88	0.88	0.88
3 (7)	0.50	0.25	0.88	0.88	0.88
4 (8)	0.50	0.38	0.88	0.88	0.88

Threaded Mounting Holes Available either or both ends.

1/2" Bore (HR shown)

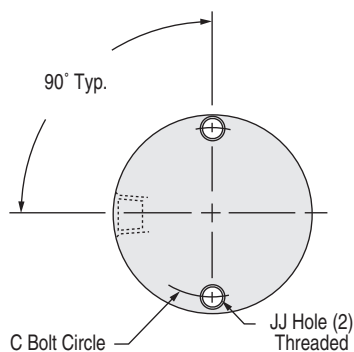

3/4" Bore & Up

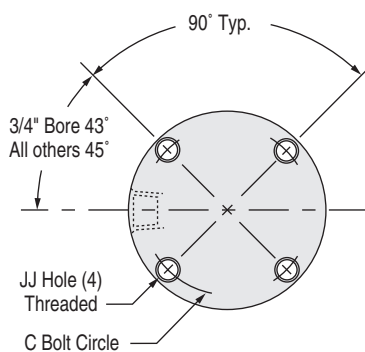

Nose Mount

Available on PSD, PSR, and PSX. (F shown) Includes rod wiper and heavy duty rear head. See length adder above.

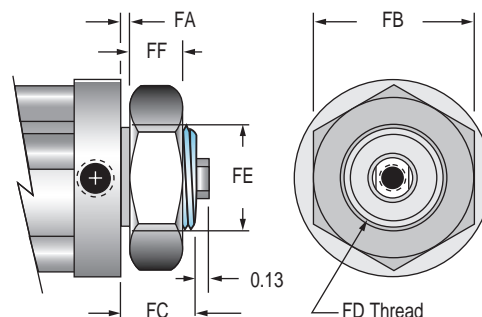

Dimensions (inches)

Bore	C	JJ	FA	FB	FC	FD	FE	FF
1/2 (1)	0.88	#4 – 40 UNC	.06	0.75 Hex	.38	1/2 – 20 UNF-2A	.50	.31
3/4 (2)	1.22	#6 – 32 UNC	.06	0.75 Hex	.38	5/8 – 18 UNF-2A	.62	.25
1-1/16 (3)	1.69	#6 – 32 UNC	.13	1.50 Hex	.75	1 – 14 UNF-2A	1.00	.55
1-1/2 (4)	2.19	# 10 – 24 UNC	.13	1.88 Hex	.75	1-1/4 – 12 UNF-2A	1.25	.52
2 (5)	2.69	# 10 – 24 UNC	.19	1.88 Hex	.88	1-3/8 – 12 UNF-2A	1.38	.52
2-1/2 (6)	3.25	1/4 – 20 UNC	.25	1.88 Hex	1.00	1-3/8 – 12 UNF-2A	1.38	.52
3 (7)	3.78	1/4 – 20 UNC	.25	1.88 Hex	1.00	1-3/8 – 12 UNF-2A	1.38	.52
4 (8)	4.94	5/16 – 18 UNC	.19	2.62 Hex	1.12	1-3/4 – 12 UN-2A	1.75	.88

Maximum Torque for Nose Mount Option

Bore	Foot-Pounds
1/2 (1)	12
3/4 (2)	28
1-1/16 (3)	100
1-1/2 (4)	120
2 (5)	130
2-1/2 (6)	130
3 (7)	130
4 (8)	150

FABCO-AIR Pancake® II Cylinders



Nonrotating, double acting 4 Bore sizes 3/4" thru 2" Strokes to 4" standard

Twin piston rods are incorporated into the cylinder head to achieve NON-ROTATION. The rods are securely fastened to the piston and tied together externally by a rod end tool bar. The tool bar insures that the rods move in tandem and provides an ideal mounting surface for any attachments required by your application. The tool bar is furnished with threaded mounting holes or optional counter-bored mounting holes.

Ratings – Standard Units all Series

- Body Self-lubricating composite
- Heads Clear anodized aluminum alloy
- Tie Bolts Stainless steel
- Rod Chrome plated stainless steel
- Piston Stainless steel
- Rod end Tool bar
- Ports Position #1
- Seals Internally lubricated Buna-N
- Lubrication Magnalube®-G
- Rod bushing Bronze
- Stroke tolerance ± 1/64"
- Media Air
- Pressure rating, maximum 200 psi
- Minimum recommended operating pressure 15 psi
- Temperature rating Cylinder -25° to +221°F (-32° to +105°C)
- Temperature rating Electronic sensors -4° to +176°F (-20° to +80°C)

Allowable Torsion Load and Rotational Tolerance

Side loading should be avoided for any cylinder application. The smaller diameter twin rods will have more deflection due to side load than the one standard rod in a comparable **Pancake® II** cylinder. However, the PND Series is designed to work satisfactorily against pure torsional loads. Maximum torsional load per bore size is shown in the following table.

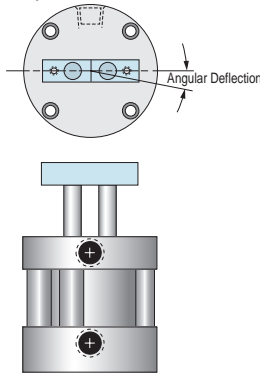

Approximate Angular Deflection (Degrees) due to max. torsional load							
Bore	Torsional Load Max.	Stroke					
		0 to 1-1/2	2	2-1/2	3	3-1/2	4
3/4	0.3 in-lbs	less than 0.22	0.51	0.98	1.67	2.62	3.88
1-1/16	1.0 in-lbs	less than 0.15	0.33	0.64	1.09	1.71	2.53
1-1/2	5.0 in-lbs	less than 0.08	0.18	0.36	0.61	0.95	1.41
2	10.0 in-lbs	less than 0.03	0.07	0.13	0.22	0.34	0.50

Freeplay Rotational Tolerance

Bore	3/4" (2)	1-1/16" (3)	1-1/2" (4)	2" (5)
Max. Rotation	±1°	±3/4°	±1/2°	±1/2°

Cylinder Sizing Guide

Bore Diameter (inch)	3/4	1-1/16	1-1/2	2
Rod Diameter (inch)	0.19	0.25	0.38	0.50
Rod Area (in ²)	0.05	0.10	0.22	0.38
Push Area (in ²)	0.44	0.88	1.76	3.14
Pull Area (in ²)	0.39	0.78	1.54	2.76

Please visit <http://portal.fabco-air.com/configure.php> for current pricing. Specifications and prices subject to change without notice or incurring obligation

How to Order

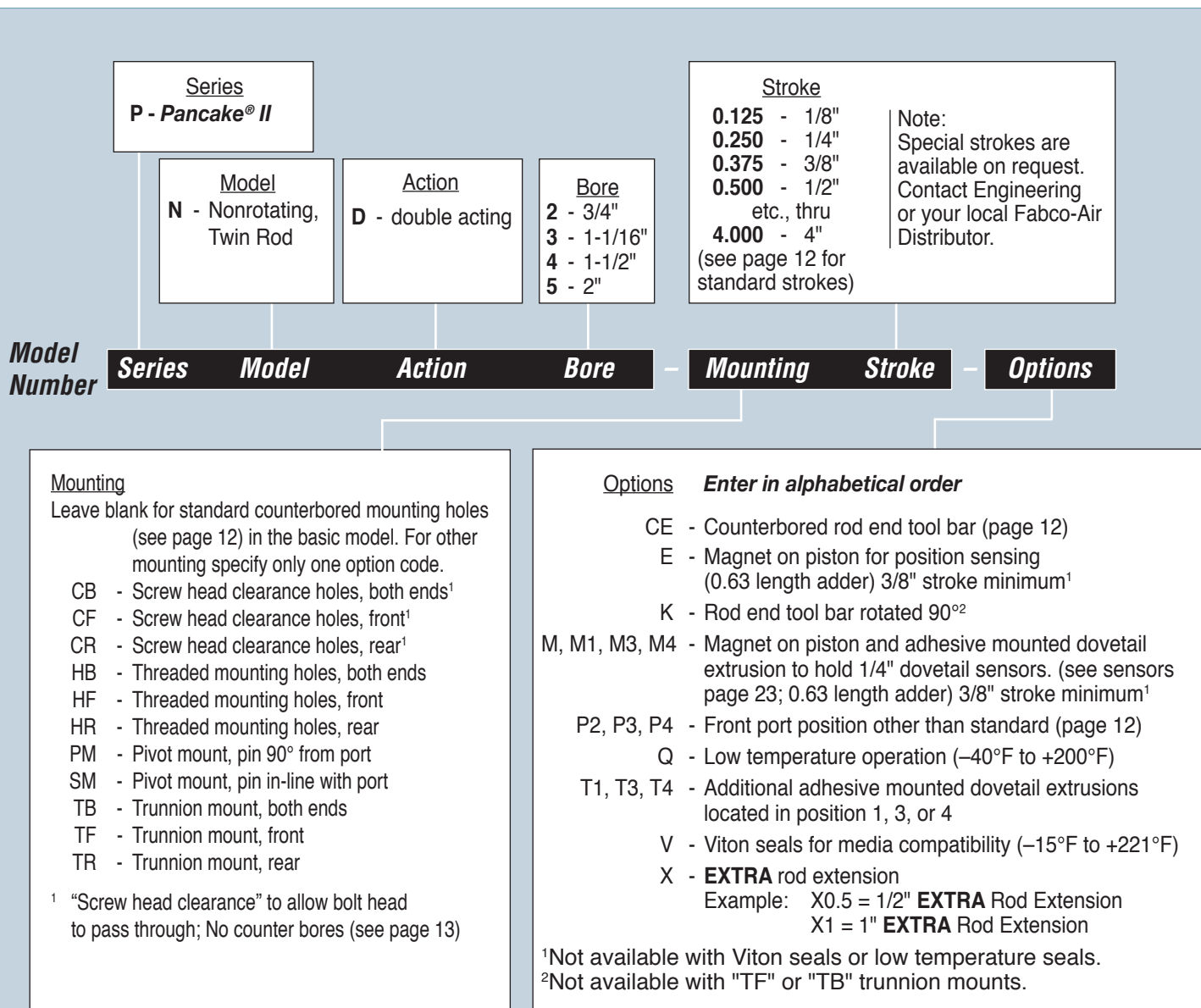

How to Order

1. Specify P, Model, Action and Bore
2. Specify optional Mounting (if required), then Stroke
3. Specify the Options in alphabetical order

Ordering example #1: PND3-PM0.375-CE

This model number specifies a **Pancake® II** nonrotating, double acting, cylinder with tool bar, 1-1/16" bore, pivot mounting, 3/8" stroke and counterbored rod end tool bar.

Ordering example #2: PND5-2.000

This model number specifies a **Pancake® II** nonrotating, double acting, cylinder with tool bar, 2" bore, standard counterbored mounting holes, and 2" stroke.

FABCO-AIR Pancake® II Cylinders

Basic Model PND

Twin Rod, Nonrotating
Double Acting

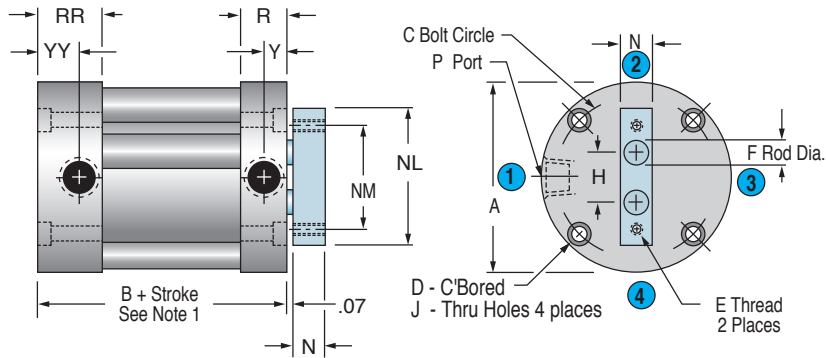

Note 1: Magnetic Position Sensing Length Adder = 0.63
A minimum stroke of 3/8" is required to sense end-of-stroke positions

Standard Strokes – All Models: • 1/8 • 1/4 • 3/8 • 1/2 • 5/8 • 3/4 • 7/8 • 1 • 1-1/4 • 1-1/2 • 1-3/4 • 2 • 2-1/2 • 3 • 3-1/2 • 4
Special strokes available. Contact Engineering or your local Fabco-Air distributor for information.

Counterbored Rod End Tool Bar

Option CE

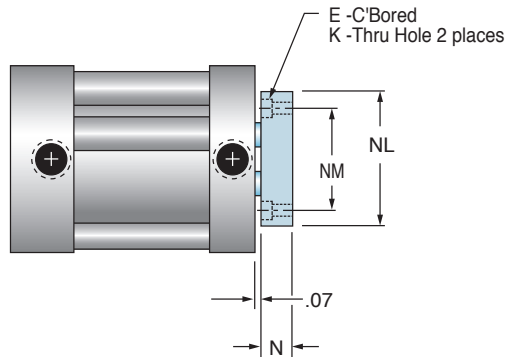

Bore	E C'Bore	K
3/4 (2)	0.24 x 0.15 dp	0.15
1-1/16 (3)	0.29 x 0.18 dp	0.18
1-1/2 (4)	0.40 x 0.27 dp	0.26
2 (5)	0.49 x 0.33 dp	0.33

Dimensions (inches)

Bore	A	B	C	D	E Thread	F	H	J	N	NL	NM	P	R	RR	Y	YY
3/4 (2)	1.49	0.94	1.22	0.24 x 0.15 dp	#6-32 UNC	0.19	0.332	0.15	0.38	1.25	0.88	#10-32 UNF	0.34	0.47	0.14	0.27
1-1/16 (3)	1.99	1.31	1.69	0.24 x 0.15 dp	#8-32 UNC	0.25	0.422	0.15	0.38	1.44	1.06	1/8 NPT	0.50	0.69	0.25	0.44
1-1/2 (4)	2.62	1.31	2.19	0.34 x 0.22 dp	1/4-20 UNC	0.38	0.562	0.20	0.50	2.00	1.50	1/8 NPT	0.50	0.69	0.25	0.44
2 (5)	3.12	1.38	2.69	0.34 x 0.22 dp	5/16-18 UNC	0.50	0.750	0.20	0.63	2.50	1.88	1/8 NPT	0.53	0.72	0.25	0.44

Nonrotating Series PND Dimensions & Options

Seal Kits – Series PND

Options	Kit Numbers by Bore Size			
	3/4"	1-1/16"	1-1/2"	2"
Standard	PN-2-SK	PN-3-SK	PN-4-SK	PN-5-SK
Viton (V)	PN-2-SKV	PN-3-SKV	PN-4-SKV	PN-5-SKV
Low Temperature (Q)	PN-2-SKQ	PN-3-SKQ	PN-4-SKQ	PN-5-SKQ

Mounting Options

Trunnion Mount

Available rear, front or both.
(TF shown solid)

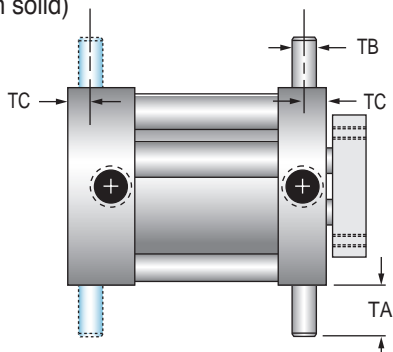

Pivot Mount

Complete with bronze pivot bushing.
Not available as an accessory. (SM shown)

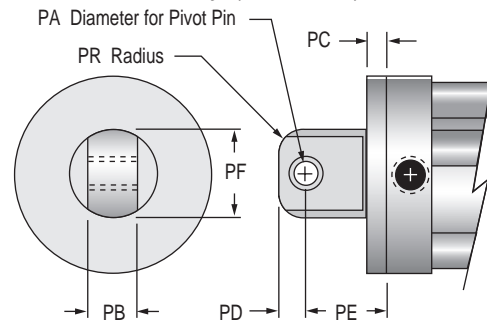

Threaded Mounting Holes

Available either or both ends. (HR shown)

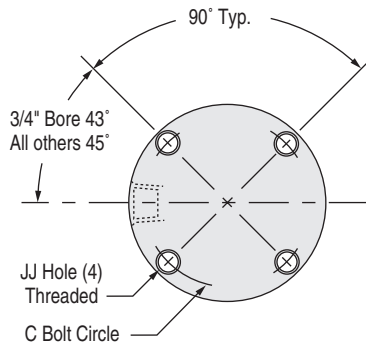

Screw Head Clearance Holes

Available either or both ends.
(CR shown)

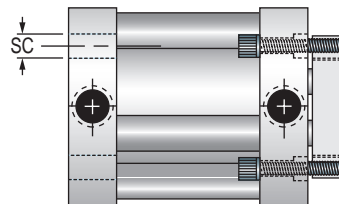

Approximate Cylinder Weights (ounces)

Bore	Base	Adder per 1/8 of Stroke
3/4 (2)	3.1	0.1
1-1/16 (3)	7.4	0.5
1-1/2 (4)	14.3	0.7
2 (5)	21.5	0.9

Dimensions (inches)

Bore	C	JJ	PA	PB	PC	PD	PE	PF	PR	SC	TA	TB	TC
3/4 (2)	1.22	#6-32 UNC	0.19	0.38	0.19	0.25	0.75	0.75	0.19	0.23	0.31	0.125	0.17
1-1/16 (3)	1.69	#6-32 UNC	0.19	0.38	0.25	0.25	0.81	0.75	0.19	0.25	0.50	0.250	0.25
1-1/2 (4)	2.19	#10-24 UNC	0.38	0.75	0.25	0.44	1.19	1.38	0.38	0.34	0.50	0.250	0.25
2 (5)	2.69	#10-24 UNC	0.38	0.75	0.31	0.44	1.25	1.38	0.38	0.34	0.50	0.250	0.25

FABCO-AIR Pancake® II Cylinders



Double acting, single rod end cylinders multiply force output. 3 Bore sizes 2-1/2" thru 4". Strokes to 4" standard.

How it Works

PA Series shown

Fabco-Air attaches multiple pistons to a common shaft and provides internal air passages through the shaft to all pistons. When air pressure is applied to the extend port, all pistons are pressurized simultaneously, enabling tremendous thrust forces to be obtained. (See the handy cylinder sizing guide below for the force multiplying factors.) When air pressure is applied to the retract port only one piston is pressurized.

NOTE: 1) Series PB is made with multiple retract and single extend cylinder action for applications requiring high pulling force. See "How to Order" and "Sizing Guide".

2) Additional retract stages are offered in the PA Series (multiple extend and single retract) with the use of ported baffles. Contact engineering for application and information. Add 0.50" length to dimension B* for each ported baffle. See "Options" R2, R3, R4 listed on page 15.

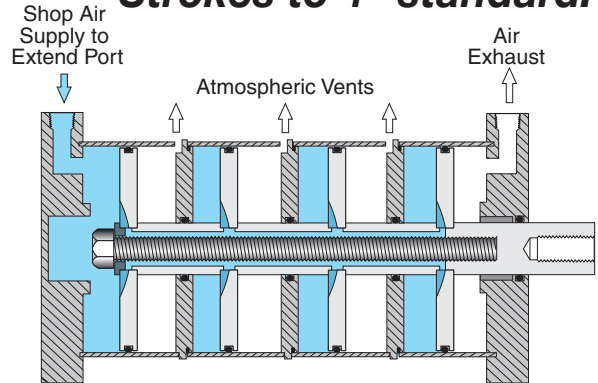

Extend Port - Air supplied to all pistons

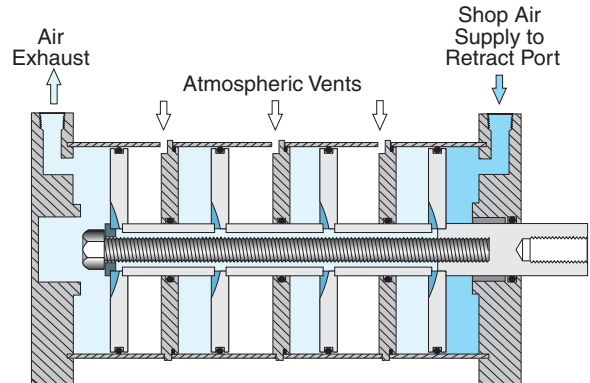

Retract Port - Air supplied to front piston only

Ratings – Standard Units all Series

- Body Self-lubricating composite
- Heads Clear anodized aluminum alloy
- Tie Bolts Stainless steel
- Rod Chrome plated stainless steel
- Piston Aluminum alloy
- Rod end Female thread with wrench flats
- Ports Position #1
- Seals Internally lubricated Buna-N
- Lubrication Magnalube®-G
- Rod bushing PTFE composite bearing
- Stroke tolerance $\pm 1/64"$ per stage
- Media Air
- Pressure rating, maximum 200 psi
- Minimum recommended operating pressure 15 psi
- Temperature rating
 - Cylinder -25° to $+221^{\circ}$ F (-32° to $+105^{\circ}$ C)
 - Electronic sensors -4° to $+176^{\circ}$ F (-20° to $+80^{\circ}$ C)

Cylinder Sizing Guide

Bore	Bore Model Designation	Extend Piston Area (in ²)			Retract Piston Area (in ²)
		PA2	PA3	PA4	
2-1/2	6	9.4	13.8	18.3	4.5
3	7	13.5	20.0	26.5	6.5
4	8	24.3	36.1	47.9	11.8

Bore	Bore Model Designation	Retract Piston Area (in ²)			Extend Piston Area (in ²)
		PB2	PB3	PB4	
2-1/2	6	8.9	13.4	17.9	4.9
3	7	12.9	19.4	25.9	7.1
4	8	23.6	35.3	47.1	12.6

How to Order

Series
P - Pancake® II

Multi-Power® Model and Action
A2 -2 stage extend, single stage retract
A3 -3 stage extend, single stage retract
A4 -4 stage extend, single stage retract
B2 -single stage extend, 2 stage retract
B3 -single stage extend, 3 stage retract
B4 -single stage extend, 4 stage retract

Bore
6 - 2-1/2"
7 - 3"
8 - 4"

Stroke
0.125 - 1/8"
0.250 - 1/4"
0.375 - 3/8"
0.500 - 1/2"
 etc., thru
4.000 - 4"
 (see page 16 for standard strokes)

Note:
 Special strokes are available on request. Contact Engineering or your local Fabco-Air Distributor.

Model Number **Series** **Model** **Action** **Bore** **Mounting** **Stroke** **Options**

Mounting

Leave blank for standard counterbored mounting holes (see page 16) in the basic model. For other mounting specify only one option code.

- CB - Screw head clearance holes, both ends¹
- CF - Screw head clearance holes, front¹
- CR - Screw head clearance holes, rear¹
- HB - Threaded mounting holes, both ends
- HF - Threaded mounting holes, front
- HR - Threaded mounting holes, rear

¹ "Screw head clearance" to allow bolt head to pass through; No counter bores (See page 17)

Options **Enter in alphabetical order**

- E - Magnet on piston for position sensing
(see length adders page 17) 3/8" stroke minimum¹
- M, M1, M3, M4 - Magnet on piston and adhesive mounted dovetail extrusion to hold 1/4" dovetail sensors. (see sensors page 23; length adders page 17) 3/8" stroke min.¹
- P2, P3, P4 - Front port position other than standard (page 16)
- P6, P7, P8 - Rear port position other than standard (page 16)
- Q - Low temperature operation (-40°F to +200°F)
- R2, R3, R4 - Total number of retract stages; available Series PA only
(see length adders page 17)
- TCF - Coarse female rod thread, dimension E (page 16)
- TCM - Male rod end with coarse thread (page 17)
- TFM - Male rod end with fine thread (page 17)
- TN - Non-threaded rod
- T1, T3, T4 - Additional adhesive mounted dovetail extrusions located in position 1, 3, or 4
- V - Viton seals for media compatibility (-15°F to +221°F)
- W - Rod wiper, Buna N only (page 17)
- X - EXTRA rod extension
 Example: X0.5 = 1/2" EXTRA Rod Extension
 X1 = 1" EXTRA Rod Extension

¹ Not available with Viton seals or low temperature seals.

How to Order

1. Specify **P**, Model, Action and Bore
2. Specify optional Mounting (if required), then Stroke
3. Specify the Options in alphabetical order

Ordering example: **PA37-HB1.000-TCFV**

This model number specifies a Multi-Power®, 3 stage extend, 1 stage retract, 3" bore cylinder, threaded mounting holes on both ends, 1" stroke, with coarse female rod thread and Viton seals.

FABCO-AIR Pancake® II Cylinders

Model PA2 or PB2

Standard Strokes – All Models: • 1/8 • 1/4 • 3/8 • 1/2 • 5/8 • 3/4 • 7/8 • 1 • 1-1/4 • 1-1/2 • 1-3/4 • 2 • 2-1/2 • 3 • 3-1/2
 • 4 Special strokes available on request. Contact Engineering or your local Fabco-Air Distributor

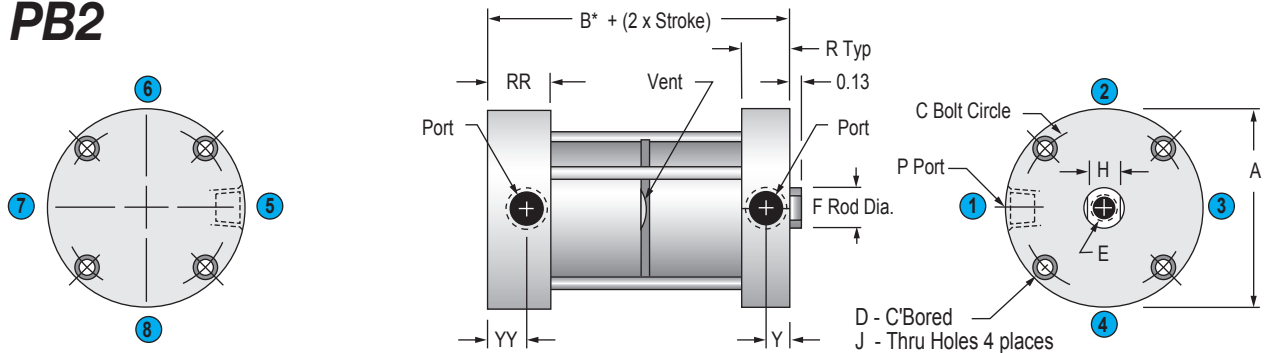

Model PA3 or PB3

Standard Strokes – All Models: • 1/8 • 1/4 • 3/8 • 1/2 • 5/8 • 3/4 • 7/8 • 1 • 1-1/4 • 1-1/2 • 1-3/4 • 2 • 2-1/2 • 3 • 3-1/2
 • 4 Special strokes available on request. Contact Engineering or your local Fabco-Air Distributor

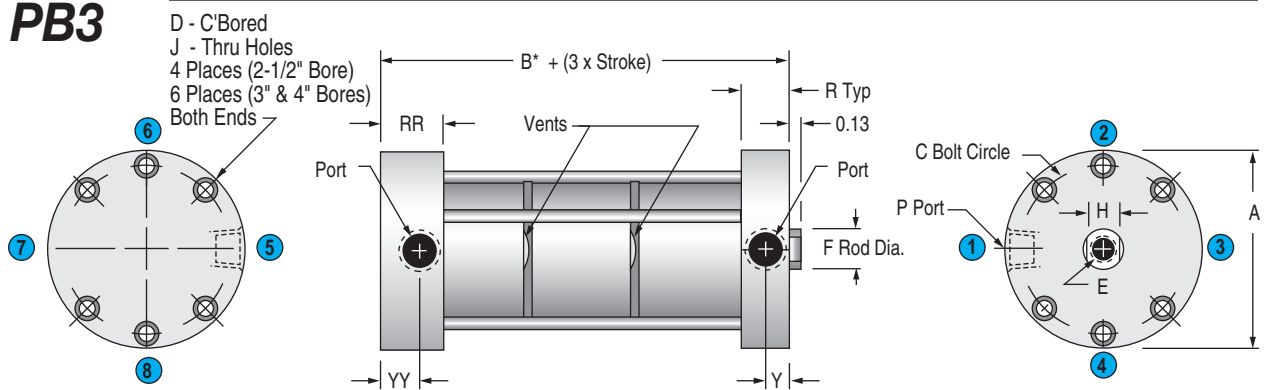

Model PA4 or PB4

Standard Strokes – All Models: • 1/8 • 1/4 • 3/8 • 1/2 • 5/8 • 3/4 • 7/8 • 1 • 1-1/4 • 1-1/2 • 1-3/4 • 2 • 2-1/2 • 3 • 3-1/2
 • 4 Special strokes available on request. Contact Engineering or your local Fabco-Air Distributor

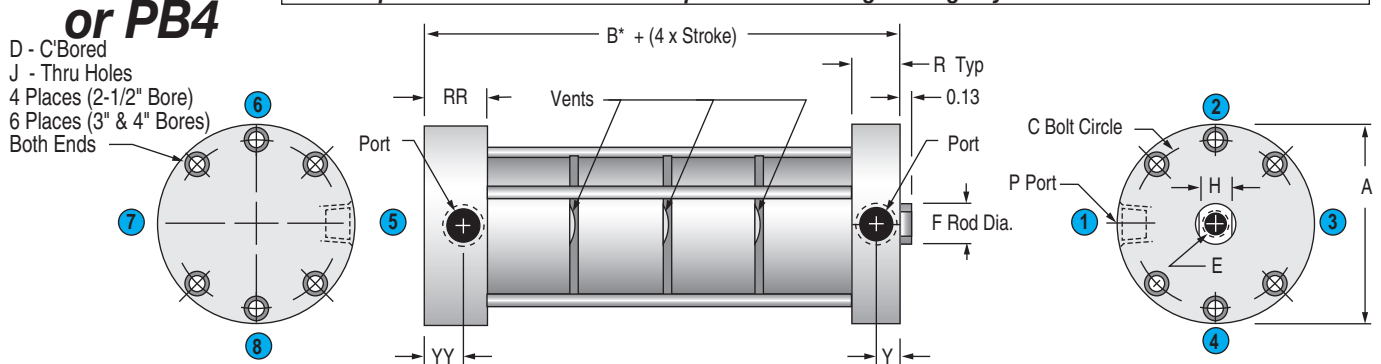

*Dimension "B" for Strokes .125, .188, and .250 (inches)

Bore	.125 Stroke			.188 Stroke			.250 Stroke		
	PA2 or PB2	PA3 or PB3	PA4 or PB4	PA2 or PB2	PA3 or PB3	PA4 or PB4	PA2 or PB2	PA3 or PB2	PA4 or PB2
2-1/2 (6)	2.65	3.64	4.63	2.71	3.76	4.81	2.77	3.87	4.97
3 (7)	2.75	3.77	4.79	2.81	3.90	4.98	2.88	4.01	5.15
4 (8)	3.38	4.61	5.85	3.44	4.74	6.04	3.53	4.89	6.24

Dimensions (inches)

Bore	A	B* (strokes over .250)			C	D C'Bore	E Female Thread		E Depth for Stroke Range		F	H	J	P	R	RR	Y	YY
		PA2 or PB2	PA3 or PB3	PA4 or PB4			E Standard	E Course	1/8 - 1/2	5/8 +								
		2-1/2 (6)	3.75	2.29			3.15	4.02	3.25	0.40 x 0.27 dp								
3 (7)	4.25	2.39	3.28	4.18	3.78	0.40 x 0.27 dp	5/8-18 UNF	5/8-11 UNC	0.45-0.73	0.73	0.88	0.75	0.26	1/4 NPT	0.69	0.94	0.33	0.58
4 (8)	5.50	3.04	4.15	5.27	4.94	0.49 x 0.33 dp	3/4-16 UNF	3/4-10 UNC	0.40-0.70	0.80	1.00	0.88	0.33	3/8 NPT	0.84	1.22	0.42	0.80

Multi-Power® Series PA & PB Models & Options

Seal Kits - Multi-Power® Series PA & PB

Options	Kit Numbers by Stages and Bore Size								
	PM2-2 1/2"	PM2-3"	PM2-4"	PM3-2 1/2"	PM3-3"	PM3-4"	PM4-2 1/2"	PM4-3"	PM4-4"
Standard	PM2-6-SK	PM2-7-SK	PM2-8-SK	PM3-6-SK	PM3-7-SK	PM3-8-SK	PM4-6-SK	PM4-7-SK	PM4-8-SK
Viton (V)	PM2-6-SKV	PM2-7-SKV	PM2-8-SKV	PM3-6-SKV	PM3-7-SKV	PM3-8-SKV	PM4-6-SKV	PM4-7-SKV	PM4-8-SKV
Low Temperature (Q)	PM2-6-SKQ	PM2-7-SKQ	PM2-8-SKQ	PM3-6-SKQ	PM3-7-SKQ	PM3-8-SKQ	PM4-6-SKQ	PM4-7-SKQ	PM4-8-SKQ

Mounting Options

Threaded Mounting Holes

Available either or both ends. (HR shown)

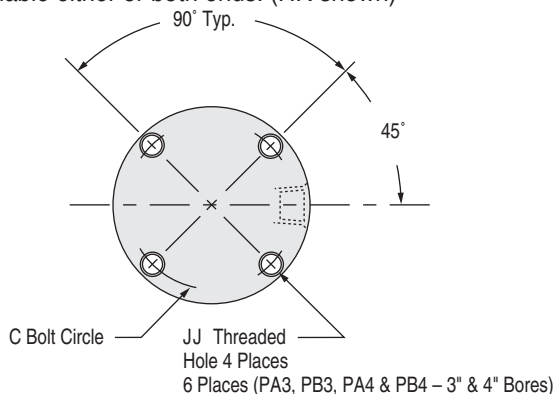

Screw Head Clearance Holes

Available either or both ends. (CR shown)

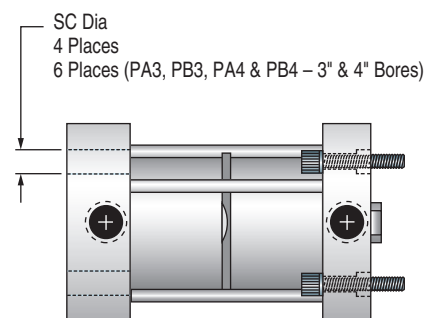

Model Options

Male Rod Ends
(Option TCM or Option TFM)
(Model PA2 shown)

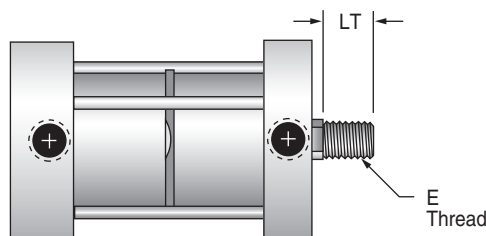

Rod Wiper
(Option W)
Buna-N only.
(Model PA2 shown)

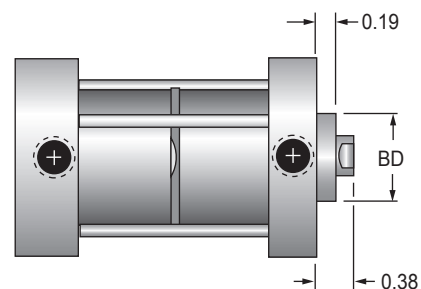

Approximate Cylinder Weights (ounces)

Bore	PA2, PB2		PA3, PB3		PA4, PB4	
	Base	Adder per 1/8 Stroke	Base	Adder per 1/8 Stroke	Base	Adder per 1/8 Stroke
2-1/2 (6)	37.2	1.2	53.3	1.8	69.4	2.4
3 (7)	49.9	1.6	71.0	2.4	92.1	3.2
4 (8)	93.1	2.0	133.8	3.0	174.5	4.0

Dimensions (inches)

Bore	BD	C	JJ	E Male Thread		LT	SC
				TCM (Coarse)	TFM (Fine)		
2-1/2 (6)	1.13	3.25	1/4 - 20 UNC	1/2-13 UNC	1/2-20 UNF	0.63	0.41
3 (7)	1.25	3.78	1/4 - 20 UNC	5/8-11 UNC	5/8-18 UNF	0.75	0.41
4 (8)	1.38	4.94	5/16 - 18 UNC	3/4-10 UNC	3/4-16 UNF	0.75	0.50

Length Adder for Options (inches)

Bore	Series	Magnetic Position Sensing† (E or M)	Ported Baffle	
			Retract Stages	Port Size
2-1/2	PA2, PB2	0.88	R2 0.50	1/4 NPT
	PA3, PB3		R3 1.00	1/4 NPT
	PA4, PB4		R4 1.50	1/4 NPT
3	PA2, PB2	0.88	R2 0.50	1/4 NPT
	PA3, PB3		R3 1.00	1/4 NPT
	PA4, PB4		R4 1.50	1/4 NPT
4	PA2, PB2	0.88	R2 0.50	1/4 NPT
	PA3, PB3		R3 1.00	1/4 NPT
	PA4, PB4		R4 1.50	1/4 NPT

† 1) A minimum stroke of 3/8" is required to sense end-of-stroke positions.
2) Magnet is applied to front piston.

FABCO-AIR Pancake® II Cylinders



**Double acting, single rod end
Cylinder provides 3 positions
8 Bore sizes 1/2" thru 4"
Strokes to 4" standard**

Other multi-position cylinders (4 position, 5 position, etc.) are available as specials. Contact Engineering or your local Fabco-Air distributor for more information.

Ratings – Standard Units all Series

- Body Self-lubricating composite
- Heads Clear anodized aluminum alloy
- Tie Bolts Stainless steel
- Rod Chrome plated stainless steel
- Piston Aluminum alloy
- Rod end. Female thread & wrench flats
- Ports Position #1
- Seals Internally lubricated Buna-N
- Lubrication. Magnalube®-G
- Rod bushing PTFE composite bearing
- Stroke tolerance ± 1/64" per stroke
- Media Air
- Pressure rating, maximum 200 psi
- Minimum recommended operating pressure 15 psi
- Temperature rating Cylinder -25° to +221°F (-32° to +105°C)
- Temperature rating Electronic sensors -4° to +176°F (-20° to +80°C)

Cylinder Sizing Guide

Bore Diameter (inch)	1/2	3/4	1-1/16	1-1/2	2	2 1/2	3	4
Rod Diameter (inch)	0.25	0.31	0.50	0.63	0.75	0.75	0.88	1.00
Rod Area (in ²)	0.05	0.08	0.19	0.31	0.44	0.44	0.60	0.79
Push Area (in ²)	0.20	0.44	0.88	1.76	3.14	4.91	7.07	12.57
Pull Area (in ²)	0.15	0.36	0.69	1.45	2.66	4.47	6.47	11.78

How it Works

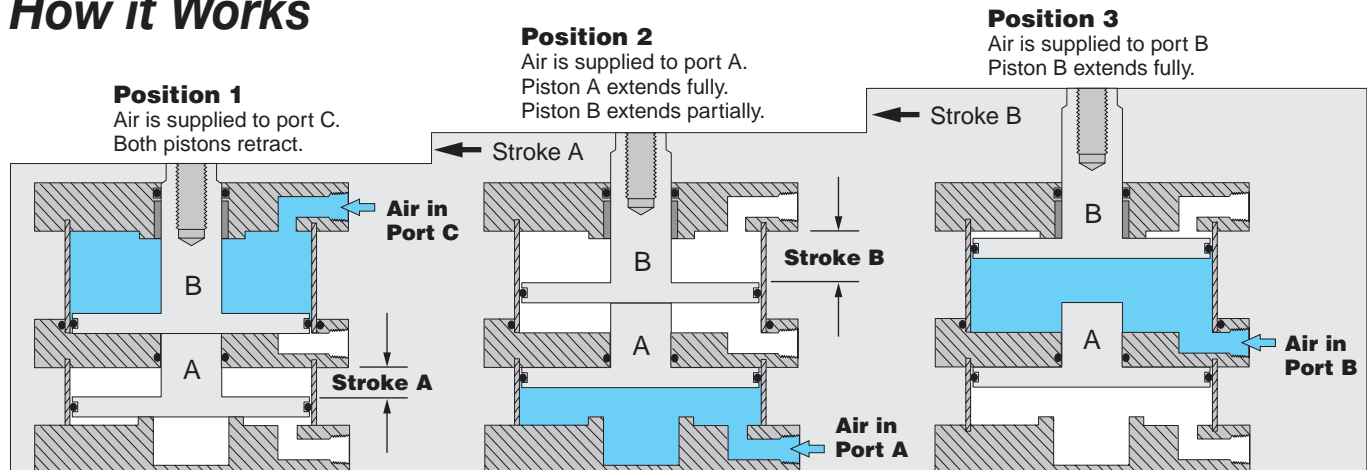

Please visit <http://portal.fabco-air.com/configure.php> for current pricing.
Specifications and prices subject to change without notice or incurring obligation

How to Order

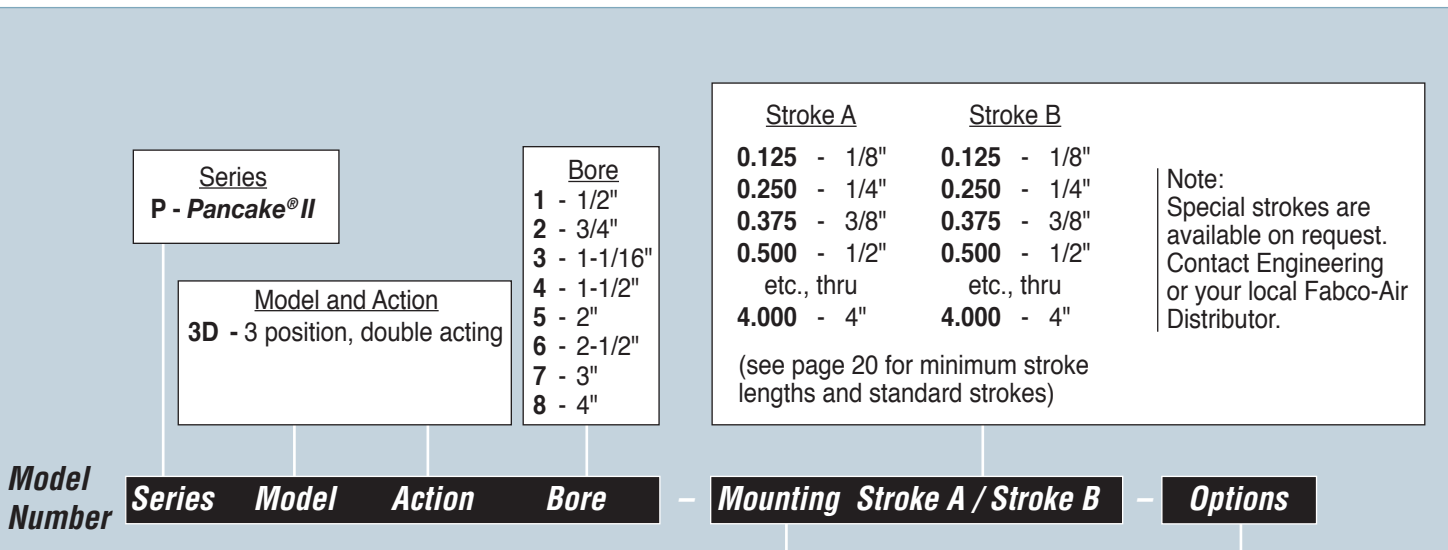

Mounting

Leave blank for standard counterbored mounting holes (see page 20) in the basic model. For other mounting specify only one option code.

- CB - Screw head clearance holes, both ends¹
- CF - Screw head clearance holes, front¹
- CR - Screw head clearance holes, rear¹
- HB - Threaded mounting holes, both ends
- HF - Threaded mounting holes, front
- HR - Threaded mounting holes, rear
- PM - Pivot mount, pin 90° from port
- SM - Pivot mount, pin in-line with port

¹ "Screw head clearance" to allow bolt head to pass through; No counter bores (see page 21)

Options *Enter in alphabetical order*

- E - Magnet on rod end piston for position sensing (see length adders page 20) 3/8" stroke minimum¹
- L - Low friction seals (see length adders page 20)
- M, M1, M3, M4 - Magnet on piston and adhesive mounted dovetail extrusion to hold 1/4" dovetail sensors. (see sensors page 23; length adders page 20) 3/8" stroke min.¹
- P2, P3, P4 - Front port position other than standard (page 20)²
- P6, P7, P8 - Rear port position other than standard (page 20)²
- Q - Low temperature operation (-40°F to +200°F)
- TCF - Coarse female rod thread, dimension E (page 20)
- TCM - Male rod end with coarse thread (page 20)
- TFM - Male rod end with fine thread (page 20)
- TN - Non-threaded rod
- T1, T3, T4 - Additional adhesive mounted dovetail extrusions located in position 1, 3, or 4
- V - Viton seals for media compatibility (-15°F to +221°F)
- W - Rod wiper, Buna N only (page 20)
- X - **EXTRA** rod extension
Example: X0.5 = 1/2" **EXTRA** Rod Extension
X1 = 1" **EXTRA** Rod Extension

¹ Not available with Viton seals or low temperature seals.
² P2, P4, P6 and P8 not available in 1/2" bore.

How to Order

1. Specify P, Model, Action and Bore
2. Specify optional Mounting (if required), then Stroke
3. Specify the Options desired

Ordering example: **P3D5-CR0.375/2.000-TCM**

This model number specifies a 3-position, double acting cylinder, 2" bore, screw clearance holes at rear, 3/8" stroke A, 2" stroke B, and male rod end with coarse thread.

FABCO-AIR Pancake® II Cylinders

Basic Model

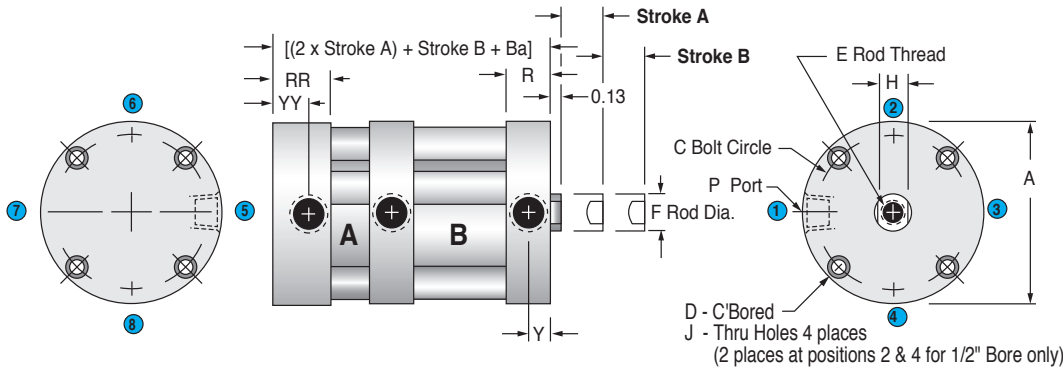

Minimum Stroke*	
Bore	Base Model Stroke A
1/2 (1)	0.19
3/4 (2)	0.19
1-1/16 (3)	0.25
1-1/2 (4)	0.25
2 (5)	0.25
2-1/2 (6)	0.38
3 (7)	0.38
4 (8)	0.34

*Note:
 1) No minimum for stroke B.
 2) No minimum for stroke A or B with Low Friction Option -L

Standard Strokes - • 1/8 • 1/4 • 3/8 • 1/2 • 5/8 • 3/4 • 7/8 • 1 • 1-1/4 • 1-1/2 • 1-3/4 • 2 • 2-1/2 • 3 • 3-1/2 • 4
 Special strokes available on request. Contact Engineering or your local Fabco-Air Distributor

Model Options

Rod Wiper (Option W)

Buna-N only.

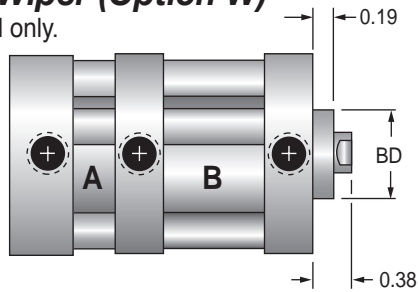

Male Rod Ends (Option TCF or TFM)

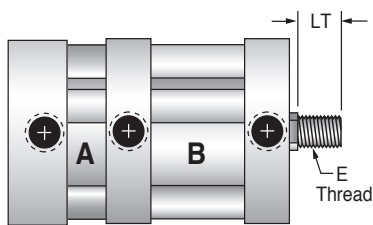

Deviations from Standard Dimensions (Options L, E, M)

Bore	Length Adder (inches)		
	Low Friction Seals (L)	Magnetic Position Sensing [†] (E or M)	Low Friction Seals & Magnetic Position Sensing [†] (EL or LM)
1/2 (1)	0.50	0.88	1.13
3/4 (2)	0.50	0.88	1.13
1-1/16 (3)	0.75	0.88	1.25
1-1/2 (4)	0.75	0.88	1.25
2 (5)	0.75	0.88	1.25
2-1/2 (6)	0.75	0.88	1.25
3 (7)	1.00	0.88	1.38
4 (8)	1.00	0.88	1.38

†1) A minimum stroke of 3/8" is required to sense end-of-stroke positions.
 2) Magnet is applied to piston of stroke B.

Dimensions (inches)

Bore	A	Ba	BD	C	D C'Bore	E Female Thread		E Depth for Stroke Range		F	H	J	LT	P	R	RR	Y	YY
						E Standard	E Course	1/8 - 1/2	5/8 +									
1/2 (1)	1.12	1.14	0.56	0.88	0.20 x 0.13 dp	#8-32 UNC	N/A	0.30-0.46	0.46	0.25	0.22	0.13	0.38	#10-32 UNF	0.34	0.47	0.14	0.27
3/4 (2)	1.49	1.14	0.69	1.22	0.24 x 0.15 dp	#10-32 UNF	#10-24 UNC	0.30-0.46	0.46	0.31	0.25	0.15	0.38	#10-32 UNF	0.34	0.47	0.14	0.27
1-1/16 (3)	1.99	1.67	0.88	1.69	0.24 x 0.15 dp	5/16-24 UNF	5/16-18 UNC	0.37-0.63	0.70	0.50	0.44	0.15	0.50	1/8 NPT	0.50	0.69	0.25	0.44
1-1/2 (4)	2.62	1.70	1.00	2.19	0.34 x 0.22 dp	3/8-24 UNF	3/8-16 UNC	0.37-0.70	0.70	0.63	0.50	0.20	0.50	1/8 NPT	0.50	0.69	0.25	0.44
2 (5)	3.12	1.80	1.13	2.69	0.34 x 0.22 dp	1/2-20 UNF	1/2-13 UNC	0.30-0.63	0.70	0.75	0.63	0.20	0.63	1/8 NPT	0.53	0.72	0.25	0.44
2-1/2 (6)	3.75	2.25	1.13	3.25	0.40 x 0.27 dp	1/2-20 UNF	1/2-13 UNC	0.42-0.70	0.70	0.75	0.63	0.26	0.63	1/4 NPT	0.66	0.91	0.33	0.58
3 (7)	4.25	2.34	1.25	3.78	0.40 x 0.27 dp	5/8-18 UNF	5/8-11 UNC	0.45-0.73	0.73	0.88	0.75	0.26	0.75	1/4 NPT	0.69	0.94	0.33	0.58
4 (8)	5.50	3.00	1.38	4.94	0.49 x 0.33 dp	3/4-16 UNF	3/4-10 UNC	0.40-0.70	0.80	1.00	0.88	0.33	0.75	3/8 NPT	0.84	1.22	0.42	0.80

Seal Kits - Multi-Position Series P3D

Options	Kit Numbers by Bore Size							
	1/2"	3/4"	1-1/16"	1-1/2"	2"	2-1/2"	3"	4"
Standard	P3-1-SK	P3-2-SK	P3-3-SK	P3-4-SK	P3-5-SK	P3-6-SK	P3-7-SK	P3-8-SK
Viton (V)	P3-1-SKV	P3-2-SKV	P3-3-SKV	P3-4-SKV	P3-5-SKV	P3-6-SKV	P3-7-SKV	P3-8-SKV
Low Temperature (Q)	P3-1-SKQ	P3-2-SKQ	P3-3-SKQ	P3-4-SKQ	P3-5-SKQ	P3-6-SKQ	P3-7-SKQ	P3-8-SKQ
Low Friction (L)	P3-1-SKL	P3-2-SKL	P3-3-SKL	P3-4-SKL	P3-5-SKL	P3-6-SKL	P3-7-SKL	P3-8-SKL
Low Friction-Viton (L, V)	P3-1-SKLV	P3-2-SKLV	P3-3-SKLV	P3-4-SKLV	P3-5-SKLV	P3-6-SKLV	P3-7-SKLV	P3-8-SKLV
Low Friction-Low Temperature (L, Q)	P3-1-SKLQ	P3-2-SKLQ	P3-3-SKLQ	P3-4-SKLQ	P3-5-SKLQ	P3-6-SKLQ	P3-7-SKLQ	P3-8-SKLQ

Mounting Options

Threaded Mounting Holes

Available either or both ends. (HR shown)

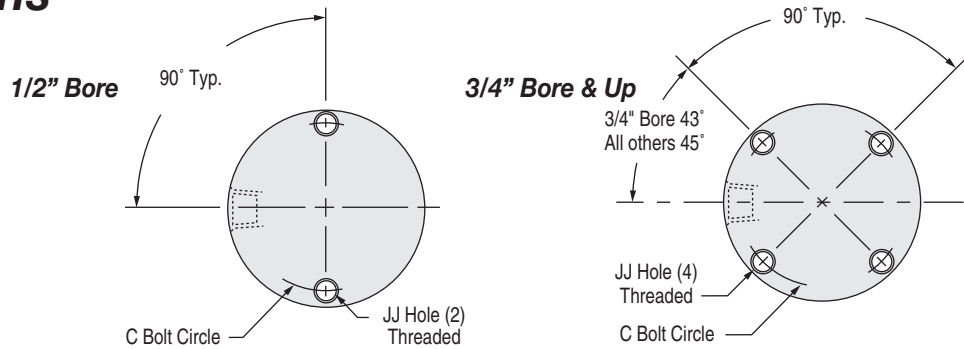

Screw Head Clearance Holes

Available either or both ends. (CR shown)
Screw head clearance holes are standard on all center sections.

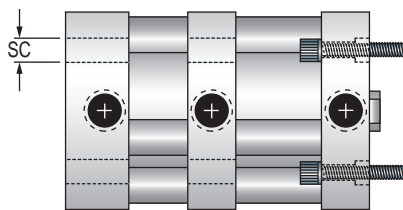

Pivot Mount

Complete with bronze pivot bushing. (SM shown)
Not available as an accessory

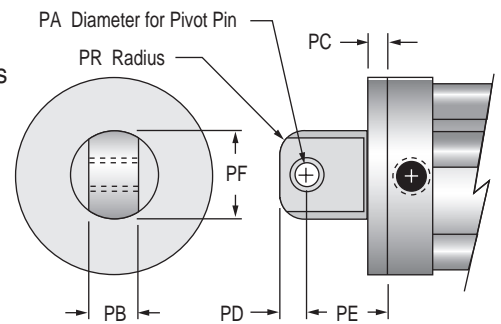

Dimensions (inches)										
Bore	C	JJ	PA	PB	PC	PD	PE	PF	PR	SC
1/2 (1)	0.88	#4-40 UNC	0.19	0.38	0.19	0.25	0.75	0.63	0.19	0.17
3/4 (2)	1.22	#6-32 UNC	0.19	0.38	0.19	0.25	0.75	0.75	0.19	0.23
1-1/16 (3)	1.69	#6-32 UNC	0.19	0.38	0.25	0.25	0.81	0.75	0.19	0.25
1-1/2 (4)	2.19	#10-24 UNC	0.38	0.75	0.25	0.44	1.19	1.38	0.38	0.34
2 (5)	2.69	#10-24 UNC	0.38	0.75	0.31	0.44	1.25	1.38	0.38	0.34
2-1/2 (6)	3.25	1/4-20 UNC	0.38	0.75	0.38	0.44	1.31	1.38	0.38	0.41
3 (7)	3.78	1/4-20 UNC	0.63	1.00	0.38	0.56	1.69	1.88	0.38	0.41
4 (8)	4.94	5/16-18 UNC	0.63	1.00	0.44	0.56	1.75	1.88	0.38	0.50

Approximate Cylinder Weights (ounces)

Bore	Base	Adder per 1/8 of Stroke
1/2 (1)	3.3	0.16
3/4 (2)	4.5	0.2
1-1/16 (3)	9.9	0.6
1-1/2 (4)	18.7	0.8
2 (5)	24.5	1.0
2-1/2 (6)	41.3	1.2
3 (7)	52.9	1.6
4 (8)	102.7	2.0

Selection Guide

Accessory	Standard Series	PND Series	Multi-Power Series	P3D Series
Clevis Bracket	✓	✓	N/A	✓
Trunnion Bracket	✓	✓	N/A	N/A
Rod Eye	✓	N/A	✓	✓

Clevis Bracket

Anodized aluminum alloy
Chrome plated steel pin included

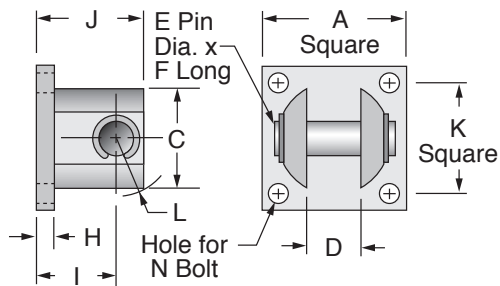

The bracket is intended for mounting with either a rod pivot or pivot mount; it is not intended to mount directly with the rear cylinder head.

Dimensions (inches)

Kit No.	Bore	A	C	D	E	F	H	I	J	K	L	N
CB-3	1/2 (1)	1.00	0.71	0.39	0.187	0.93	0.16	0.56	0.78	0.75	0.42	#6
	3/4 (2)											
	1-1/16 (3)											
CB-6	1-1/2 (4)	1.75	1.37	0.75	0.375	1.63	0.22	0.94	1.34	1.38	0.80	#10
	2 (5)											
	2-1/2 (6)											
CB-8	3 (7)	2.50	2.10	1.00	0.625	2.42	0.25	1.25	1.81	2.00	1.19	1/4
	4 (8)											

Trunnion Bracket (pair)

Anodized aluminum alloy
complete with bronze pivot bushings

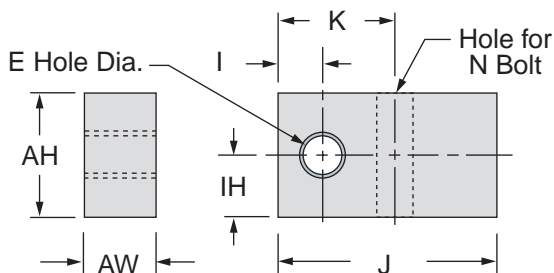

Dimensions (inches)

Kit No.	Bore	AH	AW	E	I	IH	J	K	N
TB-2	3/4 (2)	0.63	0.31	0.126	0.22	0.30	1.12	0.56	#10
TB-5	1-1/16 (3)	0.88	0.50	0.251	0.31	0.38	1.50	0.81	1/4
	1-1/2 (4)								
TB-7	2-1/2 (6)	1.00	0.63	0.313	0.38	0.45	1.63	0.94	5/16
	3 (7)								
TB-8	4 (8)	1.25	0.75	0.376	0.44	0.55	1.88	1.06	3/8

Rod Eye

Steel with bronze pivot bushing and nut

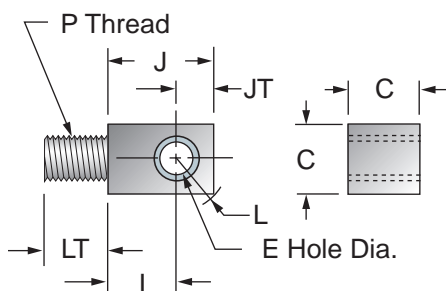

Dimensions (inches)

Kit No.	Bore	C	E	I	J	JT	L	LT	P
RE-1	1/2 (1)	0.38	0.187	0.47	0.72	0.25	0.32	0.38	#8-32 UNC
RE-2	3/4 (2)	0.38	0.187	0.47	0.72	0.25	0.32	0.38	#10-32 UNF
RE-3	1-1/16 (3)	0.38	0.187	0.47	0.72	0.25	0.32	0.63	5/16-24 UNF
RE-4	1-1/2 (4)	0.75	0.375	0.72	1.16	0.44	0.58	0.63	3/8-24 UNF
RE-6	2 (5)	0.75	0.375	0.72	1.16	0.44	0.58	0.75	1/2-20 UNF
	2-1/2 (6)								
RE-7	3 (7)	1.00	0.625	1.00	1.63	0.63	0.80	0.88	5/8-18 UNF
RE-8	4 (8)	1.00	0.625	1.00	1.63	0.63	0.80	0.88	3/4-16 UNF

Sensor Specifications & Ordering Information

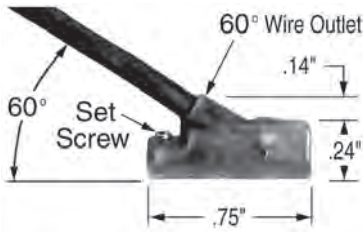

- Encased in a plastic housing, dovetail style electronic sensors are corrosion resistant. 60° wire outlet allows close mounting.
- Two methods of mounting are available:
 - Tie bolt spacer mounted clamps (Option -E)
 - Adhesive mounted dovetail extrusions (Option -M)
- Order sensors separately from the table below

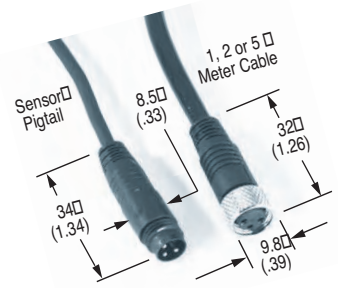

Ordering Guide – Dovetail Style Magnetic Sensor with LED				Sensor Temperature Range -20° to +80° C (-4° to +176° F)	Female Cordsets for Quick Disconnect								
Sensor Type	Prewired 9 ft. Part No.	Quick Disconnect Part No.*	Wire Leads	Electrical Characteristics									
Electronic	949-000-031	949-000-331	3	Sourcing PNP 6-24 VDC, 0.20 Amp Max current, 0.5 Voltage Drop	<table border="1"> <thead> <tr> <th>Length</th> <th>Part No.</th> </tr> </thead> <tbody> <tr> <td>1 Meter</td> <td>CFC-1M</td> </tr> <tr> <td>2 Meters</td> <td>CFC-2M</td> </tr> <tr> <td>5 Meters</td> <td>CFC-5M</td> </tr> </tbody> </table>	Length	Part No.	1 Meter	CFC-1M	2 Meters	CFC-2M	5 Meters	CFC-5M
Length	Part No.												
1 Meter	CFC-1M												
2 Meters	CFC-2M												
5 Meters	CFC-5M												
Electronic	949-000-032	949-000-332	3	Sinking NPN 6-24 VDC, 0.20 Amp Max current, 0.5 Voltage Drop									

Note*: Quick disconnect styles are supplied with 6 inch pigtail with male connector. Order female cordsets separately.

Option -E Magnet on piston – use spacer mounted clamps

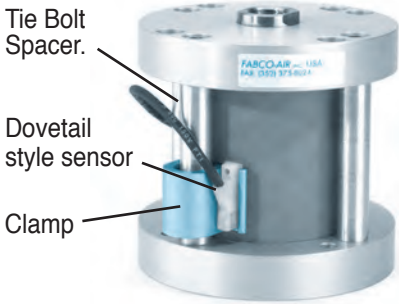

To apply dovetail style sensors first locate clamp in rough position on any of the tie bolt spacers or tie rods and lock it in place with the set screw.

Next, make fine adjustment by sliding the sensor within the clamp and lock in place with its set screw.

Clamp Selection Guide for Standard, Twin Rod & 3-Position Series						
Kit No.	SC-1	SC-2	SC-3	SC-5	SC-7	SC-8
To Fit Bore	1/2	3/4	1-1/16	1-1/2 & 2	2-1/2 & 3	4

Clamp Selection Guide for MultiPower® Series	
Kit No.	900-G00-000
To Fit Bore	All bore sizes

Order clamps and sensors separately

Option -M Magnet on piston and adhesive mounted dovetail extrusions

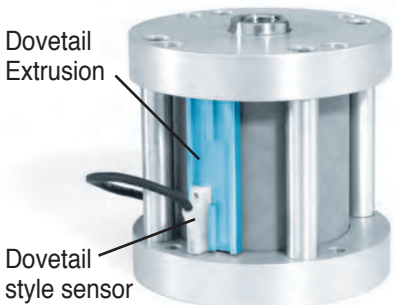

Specify Option M for mounting rail(s) located in standard position(2).

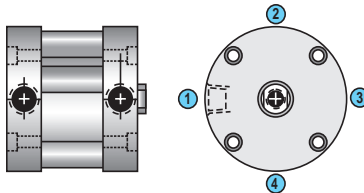

Specify option M1, M3, or M4 for mounting rail in alternate positions 1, 3, or 4 respectively. Additional dovetail rails may be applied by specifying options T1, T3, or T4.

The design and construction of the **Pan-cake II** allows the cylinder barrel to float approximately 0.020 axially. It can also rotate slightly. The axial movement will be more noticeable than the rotational movement during cylinder cycling and may present what appears to be sensor

Standard Dovetail Rail Positions		
Bore	Stroke Range	Position
1/2"	3/8" to 1-1/4"	1 & 3
1/2"	1-1/2" & above	1
3/4"	3/8" to 1-1/4"	2 & 4 [‡]
3/4"	1-1/2" & above	2
1-1/16" & up	3/8" & above	2

‡Note: When alternate positions are specified, the second of two required dovetail rails will be applied at position 2. (Contact factory for other combinations.)

malfunction when using the extruded dovetail rail. Thus, for extremely precise sensor applications where this may be troublesome, it is recommended to use the spacer-mounted clamps shown above in the -E option to provide a more stable and rigid sensor mount.

Order sensors separately

FABCO-AIR Inc. ■ 3716 N.E. 49th Avenue ■ Gainesville, FL 32609-1699
 ■ Telephone (352) 373-3578 ■ Fax (352) 375-8024 ■ E-Mail service@fabco-air.com
 ■ Web Site <http://www.fabco-air.com>

Fabco-Air Product Catalog Library



Cylinders, Valves and Accessories
Catalog #CV9

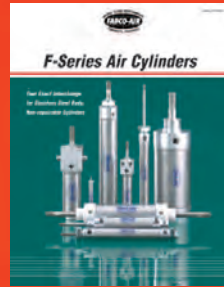

Stainless Steel Body Air Cylinders
Catalog #SSB-03



Square Pancake® II Air Cylinders
Catalog #SqPan2



ISO 6431 Cylinders
Catalog #FAQR-09



Twin Rod, Non-Rotating Air Cylinders - Catalog # FDF-09 and Catalog # FDXS-09



Multi-Power® Air Presses
Catalog #FP16

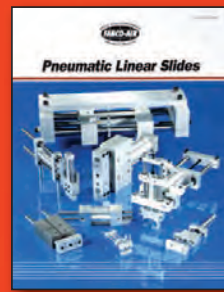

Linear Slides - 6 Families
Catalog #LS-03

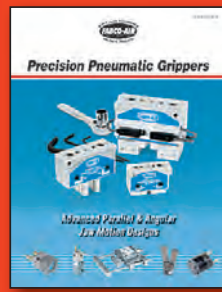

Pneumatic Grippers, Parallel Jaw and Angular Motion - Catalog # GR-8



Pneumatic Angular Grippers
Catalog #FKA-09



ISO 6432 Cylinders
Catalog #FAE-09



NFPA Interchangeable Air Cylinders - Catalog # NF-6

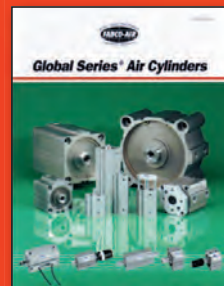

Global Series™ Metric Air Cylinders - Catalog # GC-15



Swing Clamps
Catalog #SC-DB04

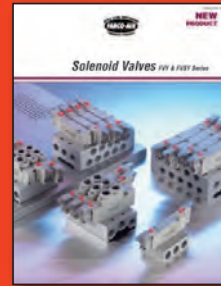

Manifold Solenoid Valves
Catalog #FVS-Y-09

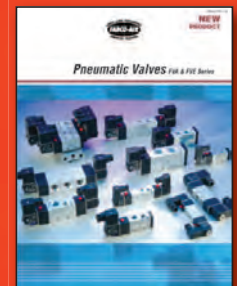

Air Pilot & Solenoid Valves
Catalog #FVA.E-09



Modular Air Preparation System - FRLs
Catalog #FRL-06



Stopper Cylinders
Catalog #ST-SC



Swing Clamps, Pneumatic & Hydraulic
Catalog #FML.H



Guided Motion Air Cylinders
Catalog #FGM-10



Air Slide Tables
Catalog #FGXS-10