

EC motors - iQ

Series iQ3600 83 mm square



Highlights:

- EC GreenTech motor
- Completely integrated electronics
- Constant speed within load capacity
- Maintenance free
- Long life expectancy
- Efficiency up to 70%
- AC-line operation
- Frequency independent
- Air flow direction dependent on selected impeller
- Leads: 480mm (18.9 in.) with brass ferruled tips
- Overload and locked rotor protection
- Moisture protection suitable for commercial refrigeration
- Grounding protection: Class 1 (earth conductor included*)
- Custom options available: reverse rotation on startup, 2nd foot mounting on .71" spacing (iQ3612 & iQ3620 only)
- Complete range of accessories: flat and basket fan guards, wall rings with motor mounts, and mounting brackets

Material: Electronic housing: Die-cast aluminum
Shaft: Stainless steel

Direction of Rotation: Counterclockwise shaft rotation (looking at shaft)

Type of Protection: IP54

Insulation Class: "H"

Mounting Position: No mounting position restrictions. On models iQ3612 & iQ3620 only; B-side tapped blind mounting holes, three M4 holes at 120° on 2.81" BC, four M4 holes at 90° on 2.81" BC

Bearings: Maintenance-free ball bearings

Product conforming to standard: Hydrocarbon refrigerant compliant: EN600079-15 / EN60335-2-89 Annex BB

Approvals: UL File XDNW2.E331218, UL File XDNW8.E331218, Electronically protected motors

* Caution: If one of the grounding mount locations on the motor housing is used, it must be connected to earth ground.

Nominal Data		Voltage Range	Frequency	Power output (1)	Speed (1)	Temperature range	Mass	Ingress protection rating	Ball Bearings	UL Approval
Model	Type	VAC	Hz	Watts	RPM	°C	lbs			
iQ3608	55330.01170	115..127	50/60	5	1,550	-40...50	1.1	IP54	Yes	Yes
iQ3612	55330.01210	115..127	50/60	15	1,550	-40...50	1.3	IP54	Yes	Yes
iQ3612	55330.01511	220...240	50/60	15	1,550	-40...50	1.3	IP54	Yes	Yes
iQ3620	55330.01514	115...127	50/60	20	1,550	-40...50	1.8	IP54	Yes	Yes
iQ3620	55330.01513	220...240	50/60	20	1,550	-40...50	1.8	IP54	Yes	Yes
iQ3620	55330.01512	115...127	50/60	20	1,850	-40...50	1.8	IP54	Yes	Yes

(1) Nominal data at maximum load.

iQ36XX

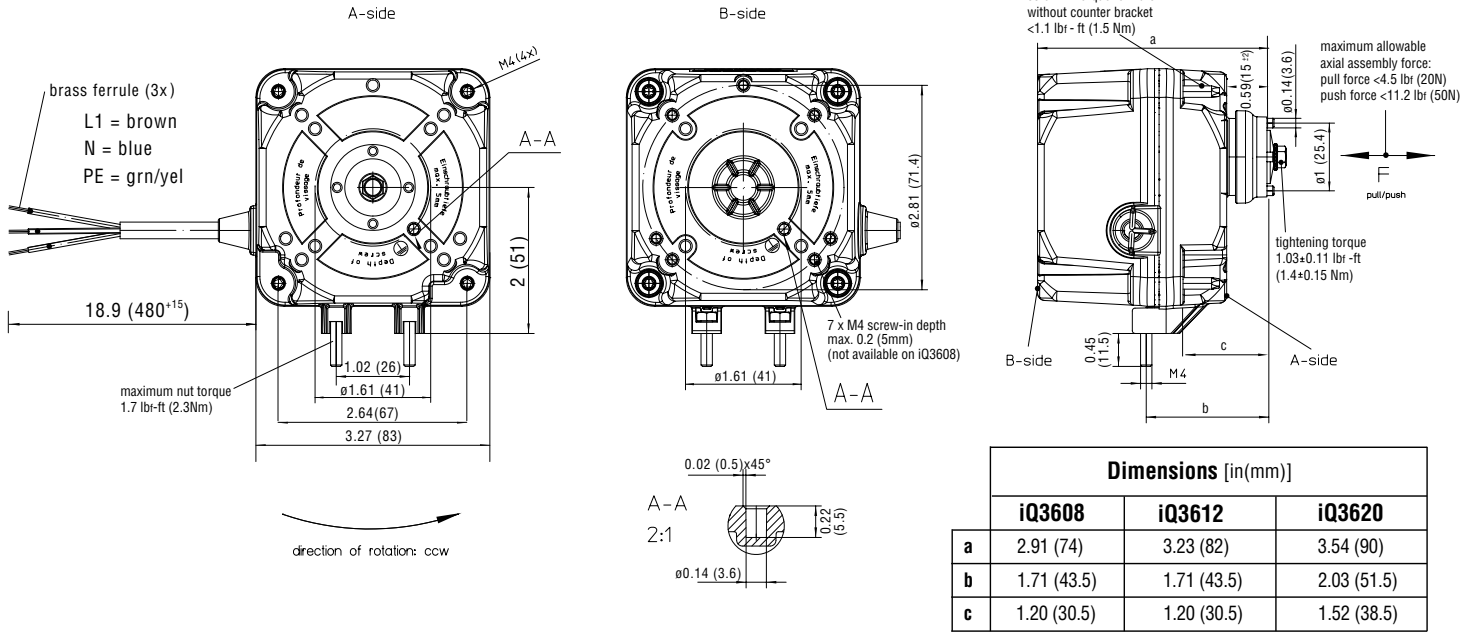

iQ Motor and Blade Selection Guide:

Chart below details the typical airflow (CFM) and input power (Watts) for available motor and blade combinations measured at free air.

Blade diameter, pitch (mm, degrees)

Model	RPM	CFM (Watts)														
		154, 22	154, 28	154, 34	172, 22	172, 28	172, 34	200, 22	200, 28	200, 34	230, 22	230, 28	230, 34	254, 22	254, 28	254, 34
iQ3608	1550	110 (2.2)	140 (2.9)	150 (3.7)	155 (3.0)	195 (4.1)	225 (5.9)	255 (4.5)	300 (6.9)							
iQ3612	1550	110 (2.2)	140 (3.0)	150 (3.7)	155 (2.8)	195 (4.0)	225 (5.4)	255 (4.3)	300 (6.5)	355 (9.3)	400 (10.1)	-----	-----	-----	-----	
iQ3620	1550	110 (3.5)	110 (3.5)	150 (5.1)	155 (4.3)	195 (5.6)	225 (6.6)	255 (5.7)	300 (8.2)	355 (10.8)	400 (10)	515 (18.8)	600 (22.3)	565 (16.8)	645 (12.7)	-----
iQ3620	1850	125 (4.6)	165 (5.8)	180 (6.9)	185 (5.7)	235 (7.2)	270 (9.5)	305 (8.3)	360 (11.1)	400 (15.0)	485 (15.7)	595 (28.0)	-----	650 (24.8)	700 (27.2)	-----

Bold: The bolded measurements indicate the smallest motor that can be used to obtain the shown airflow, with the given blade selection.

Note: Airflows are for reference only. Airflow was measured in the V-direction (discharge over motor). Airflow in the A-direction (intake over motor) is typically lower.

Other motor/blade combinations may be possible if higher flows are required at a duty point with low static pressure. Please consult ebm-papst Application Engineering to make this determination.

Please see the following pages for:

- Axial Impellers
- Finger Guards
- Wall Rings
- Mounting Brackets

Axial Impellers

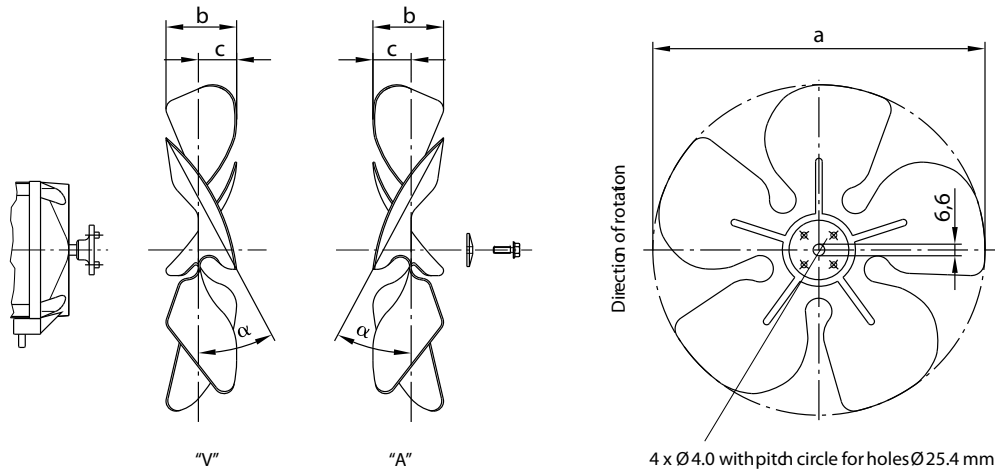

– Material: Sheet aluminium

Axial impellers

Part no. for direction of air flow "V"	Part no. for direction of air flow "A"	Blade angle α	a	b	c
73801-2-3634	73761-2-3634	$22^\circ \pm 1^\circ 30'$	154.0	27.5	14.0
73802-2-3634	73762-2-3634	$28^\circ \pm 1^\circ 30'$	154.0	32.0	16.0
73803-2-3634	73763-2-3634	$34^\circ \pm 1^\circ 30'$	154.0	37.0	18.0
73804-2-3634	73764-2-3634	$22^\circ \pm 1^\circ 30'$	172.0	31.0	14.5
73805-2-3634	73765-2-3634	$28^\circ \pm 1^\circ 30'$	172.0	36.0	17.0
73806-2-3634	73766-2-3634	$34^\circ \pm 1^\circ 30'$	172.0	42.0	21.0
73807-2-3634	73767-2-3634	$22^\circ \pm 1^\circ 30'$	200.0	32.0	15.5
73808-2-3634	73768-2-3634	$28^\circ \pm 1^\circ 30'$	200.0	37.5	18.0
73809-2-3634	73769-2-3634	$34^\circ \pm 1^\circ 30'$	200.0	45.0	22.0
73810-2-3634	73770-2-3634	$22^\circ \pm 1^\circ 30'$	230.0	35.0	17.5
73813-2-3634	73773-2-3634	$22^\circ \pm 1^\circ 30'$	254.0	37.0	19.0

subject to alterations

Finger Guards

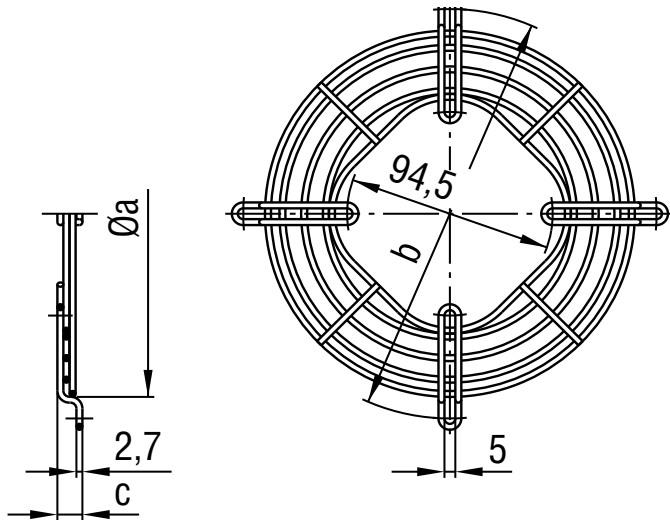

– **Material:** Steel, galvanized and blue chromated

Finger guards

Part no.	Size	Max. blade angle α at "V"	Max. blade angle α at "A"	a	b	c
50967-2-4039	154	34°	34°	170.0	190.0	11.5
50968-2-4039	172	34°	34°	188.0	208.0	11.5
50969-2-4039	200	34°	28°	214.0	236.0	11.5
50970-2-4039	230	28°	28°	246.0	266.0	17.5
50971-2-4039	254	28°	28°	270.0	290.0	17.5

subject to alterations

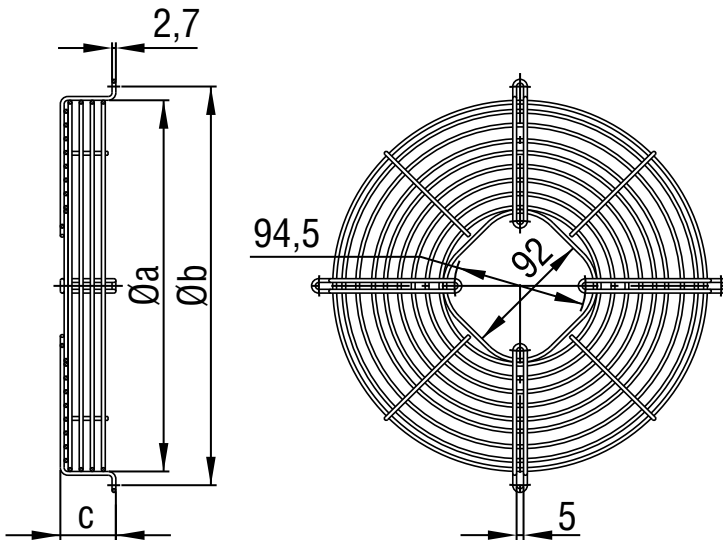

– **Material:** Steel, galvanized and blue chromated

Basket finger guards

Part no.	Size	Max. blade angle α at "V"	Max. blade angle α at "A"	a	b	c
66309-2-4039	172	34°	34°	188.0	208.0	37.5
66310-2-4039	200	34°	28°	212.0	236.0	37.5
66311-2-4039	230	28°	28°	246.0	266.0	40.0
66312-2-4039	254	28°	28°	270.0	290.0	40.0

subject to alterations

Wall Rings

– **Material:** Sheet steel, coated in grey plastic

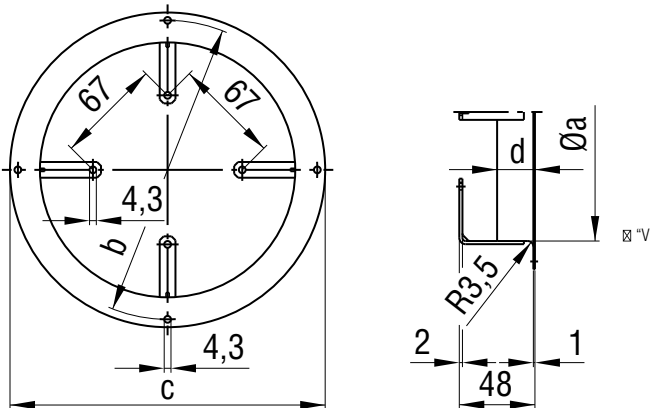

Wall rings

Part no.	Size	Max. blade angle α	a	b	c	d
52542-2-4037	154	34°	164.0	190.0	200.0	24.0
52543-2-4037	172	34°	182.0	208.0	223.0	24.0
52544-2-4037	200	34°	210.0	236.0	246.0	24.0
52545-2-4037	230	28°	240.0	266.0	276.0	24.0
52546-2-4037	254	28°	264.0	290.0	300.0	24.0

subject to alterations

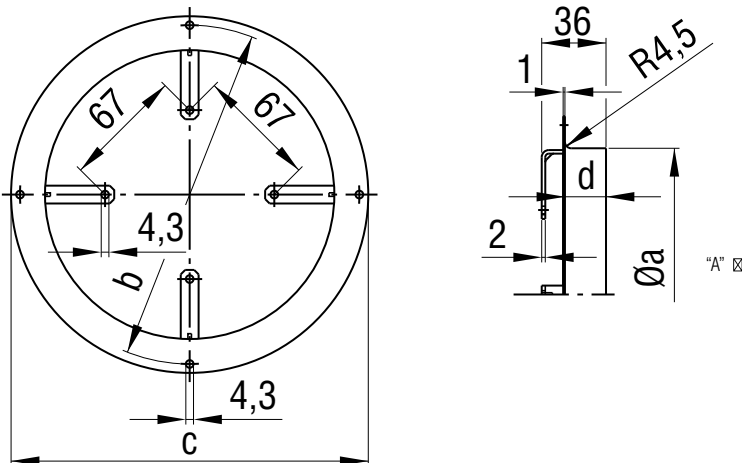

– **Material:** Sheet steel, coated in grey plastic

Wall rings

Part no.	Size	Max. blade angle α	a	b	c	d
52550-2-4037	154	34°	162.0	190.0	200.0	24.0
52551-2-4037	172	34°	180.0	208.0	223.0	24.0
52552-2-4037	200	28°	208.0	236.0	246.0	24.0
52553-2-4037	230	28°	238.0	266.0	276.0	24.0
52554-2-4037	254	28°	262.0	290.0	300.0	24.0

subject to alterations

Mounting Brackets

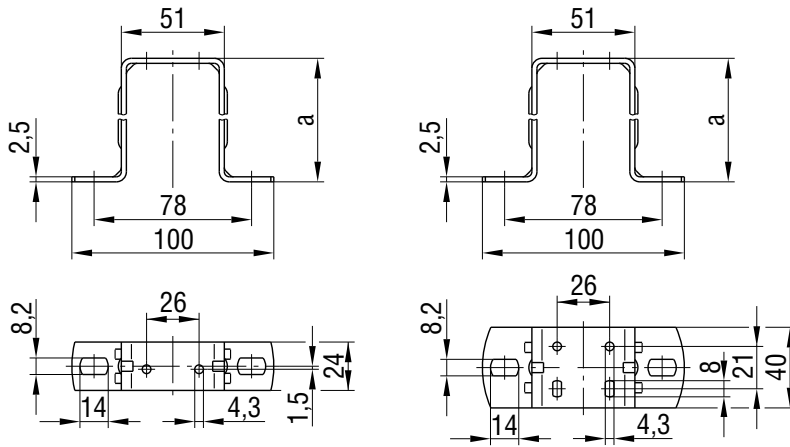

– **Material:** Sheet steel, galvanized and blue chromated

Mounting brackets – foot measure 26 mm (standard or multifunction version)

Part no.	Size	Vers.	a
71881-2-4053	154	1	39.0
71882-2-4053	172	1	52.0
71883-2-4053	200	1	72.0
	230	1	72.0
71884-2-4053	254	1	84.0
71885-2-4053	254	2	84.0

subject to alterations

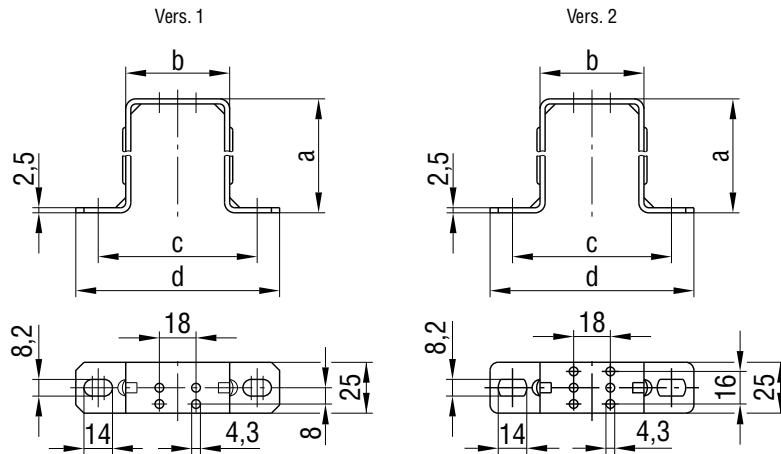

– **Material:** Sheet steel, galvanized and blue chromated

Mounting brackets – foot measure 18 mm (multifunction version)

Part no.	Size	Vers.	a	b	c	d
51025-2-4053	172	1	56.0	51.0	78.0	100.0
51028-2-4053	200	1	67.0	51.0	78.0	100.0
51026-2-4053	230	1	74.5	51.0	78.0	100.0
51027-2-4053	254	2	85.5	51.0	78.0	100.0

subject to alterations