

M-7373 8

DIMENSION SHEET FOR CAT. NO.

REPAIRABLE

NON-REPAIRABLE

B

M-7373

8

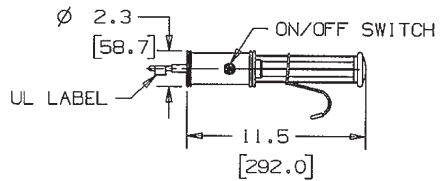
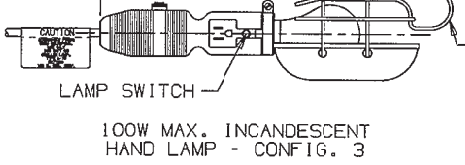
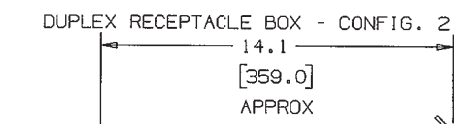
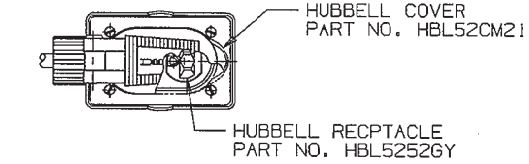
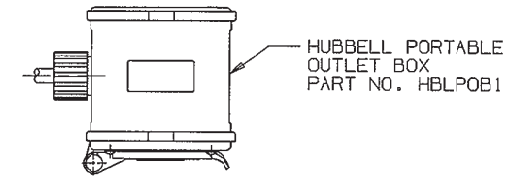
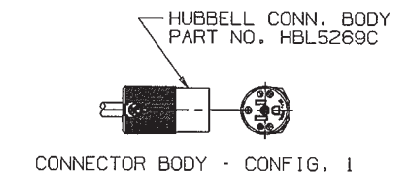

13W FLUORESCENT HAND LAMP - CONFIG. 4

CODE 745/5

HUBBELL CONNECTOR
PART NO. HBL5266C
EXCEPT FOR
HBL50163

FOR CORD TYPE &
SIZE, SEE CHART-
4 FT. LG. MIN
[1219mm]

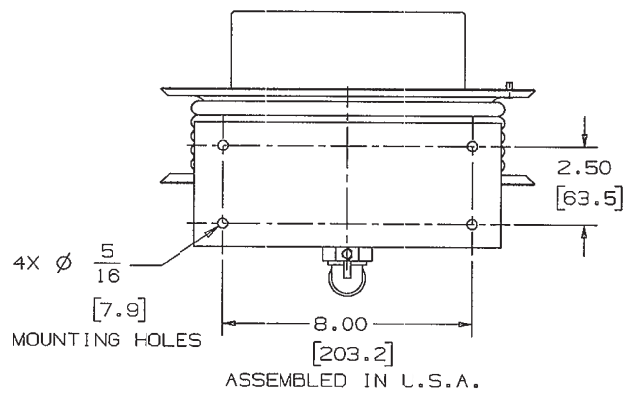
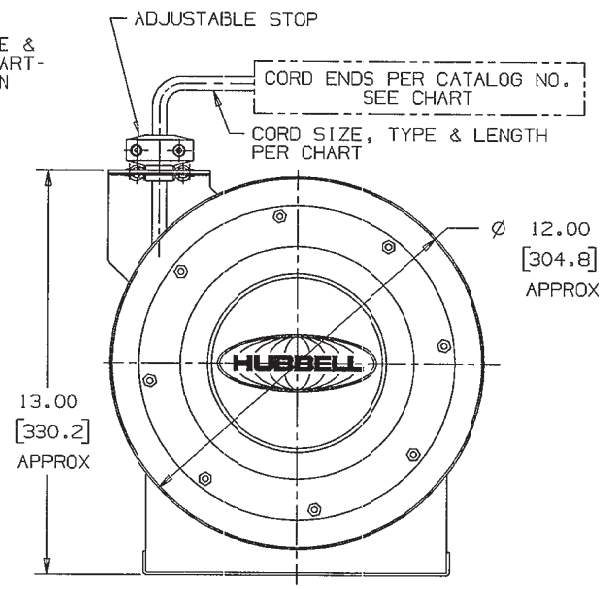
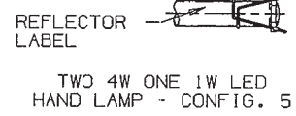
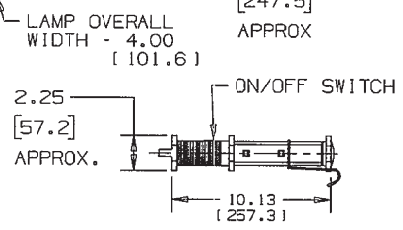
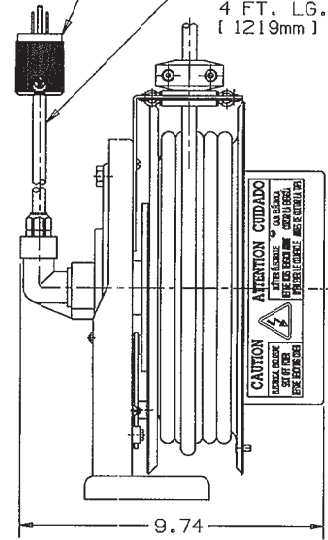

CATALOG NUMBER	APPROX. WEIGHT	DESCRIPTION	CONFIG.	CORD TYPE	CORD LENGTH
HBL45123C	25LB/11.3KG	SINGLE CONNECTOR	1	12/3 SJO	45 FT./13M
HBL45123R	25LB/11.3KG	DUPLEX RECEPTACLE BOX	2	12/3 SJO	45 FT./13M
HBL50163IN	23LB/10.4KG	INCANDESCENT HAND LAMP	3	16/3 SJO	50 FT./15M
HBL50162FL	23LB/10.4KG	FLUORESCENT HAND LAMP	4	16/3 SJO	50 FT./15M
HBL50162LED	23LB/10.4KG	LED HAND LAMP	5	16/3 SJO	50 FT./15M
HBL50163	23LB/10.4KG	PLAIN CORD ENDS	N/A	16/3 SJO	50FT./15M

LIST OF PARTS		
DESCRIPTION	MATERIAL	FINISH
INTERNAL CIRCUITRY PARTS	COPPER ALLOY	
COLLECTOR COVER	STEEL	BLACK
REEL BASE & SHEAVE	STEEL	YELLOW
CORD STOP	RUBBER	BLACK
CONNECTOR BODY (CONFIG.1)	NYLON	BLACK/NATURAL
OUTLET BOX (CONFIG.2)	P.ASTIC	YELLOW
INC. HAND LAMP (CONFIG.3)	NEOPRENE/STEEL	YELLOW/ZINC PLATE
FLUOR. HAND LAMP (CONFIG.4)	RUBBER/PLASTIC	YELLOW/CLEAR
BLANK COVER (CONFIG.2)	P.ASTIC	GREY
LIFT COVER (CONFIG.2)	P.ASTIC	YELLOW
LED HAND LAMP (CONFIG.5)	RUBBER/PLASTIC	BLACK/CLEAR

SYM	REVISIONS	APP	DATE
8	UPDATE VIEW OF CONFIG. 5 WITH LATEST VERSION OF LAMP. TWO 4W WAS EIGHT 1/2 W. PER DCN 19295 SPN	DJP	3/1/13
7	TABLE ADDED CAT. HBL50163. ADDED TO CALLOUT "EXCEPT FOR HBL50163". PER DCN 18620 SPN	DJP	2/22/12
6	ADDED HBL50162LED TO TABLE PER DCN 16741 RCM	DJP	6/29/10
5	CORD TYPE: 4 FT. [1219mm] WAS 5 FT. [1524mm] PER DCN 16295 RCM	DJP	2/23/10
4	REVISED TABLE; REVISED VIEWS TO AGREE WITH NEW DESIGN; "STEEL" WAS "ABS" FOR COLLECTOR COVER IN LIST OF PARTS PER DCN 15781 RCM	CJC	6/18/09

THE DESIGN AND DIMENSIONS OF THE PRODUCT SHOWN ON THIS DRAWING ARE SUBJECT TO CHANGE WITHOUT NOTICE

TITLE
INDUSTRIAL CORD REEL

TOLERANCES UNLESS OTHERWISE SPECIFIED	WIRING DEVICE-KELLEWS HUBBELL INCORPORATED SHELTON, CT		
.XX = ±.01	DR. BY	SRE	APP. BY CJC
.XXX = ±.005	TR. BY		SCALE NONE
ANGLES = ±2°	CHK. BY TCM		DATE 8-31-95