

# General purpose accelerometer

## 787B

### SPECIFICATIONS

<b>Sensitivity, <math>\pm 10\%</math>, 25°C</b>		100 mV/g
<b>Acceleration range</b>		80 g peak
<b>Amplitude nonlinearity</b>		1%
<b>Frequency response:</b>	$\pm 10\%$	1.0 - 5,000 Hz
	$\pm 3$ dB	0.7 - 10,000 Hz
<b>Resonance frequency</b>		22 kHz
<b>Transverse sensitivity, max</b>		5% of axial
<b>Temperature response:</b>	-25°C	-10%
	+120°C	+10%
<b>Power requirement:</b>		
Voltage source		18 - 30 VDC
Current regulating diode		2 - 10 mA
<b>Electrical noise, equiv. g:</b>		
Broadband	2.5 Hz to 25 kHz	700 $\mu$ g
Spectral	10 Hz	10 $\mu$ g/ $\sqrt$ Hz
	100 Hz	5 $\mu$ g/ $\sqrt$ Hz
	1,000 Hz	5 $\mu$ g/ $\sqrt$ Hz
<b>Output impedance, max</b>		100 $\Omega$
<b>Bias output voltage</b>		12 VDC
<b>Grounding</b>		case isolated, internally shielded
<b>Temperature range</b>		-50° to +120°C
<b>Vibration limit</b>		500 g peak
<b>Shock limit, min</b>		5,000 g peak
<b>Electromagnetic sensitivity, equiv. g, max</b>		70 $\mu$ g/gauss
<b>Sealing</b>		hermetic
<b>Base strain sensitivity, max</b>		0.002 g/ $\mu$ strain
<b>Sensing element design</b>		PZT ceramic / shear
<b>Weight</b>		145 grams
<b>Case material</b>		316L stainless steel
<b>Mounting</b>		1/4-28 captive hex head screw, 0.046" diameter safety wire hole
<b>Output connector</b>		2 pin, MIL-C-5015 style
<b>Mating connector</b>		R6 type
<b>Recommended cabling</b>		J10 / J9T2A

Accessories supplied: #80165-01 captive hex head screw; calibration data (level 2)

### Key features

- Variety of connector options available
- Low profile
- Manufactured in ISO 9001 facility

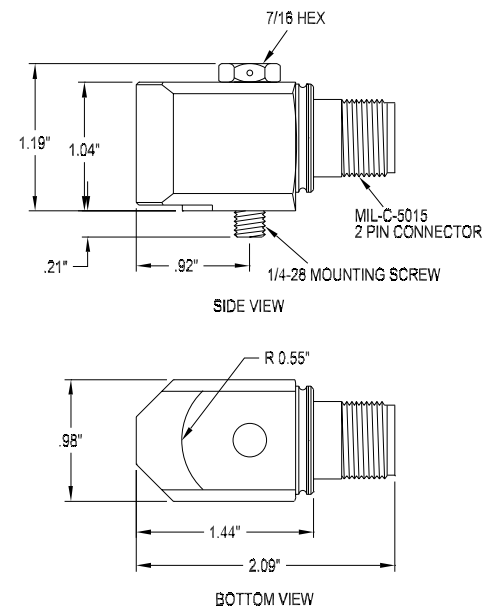

Connections	
Function	Connector pin / cable conductor color
power/signal	A / white
common	B / black
ground	shell / shield



Note: Due to continuous process improvement, specifications are subject to change without notice. This document is cleared for public release.