

Class I Div 2 certified low-frequency accelerometer

786-500-D2



SPECIFICATIONS

Sensitivity, $\pm 5\%$, 25°C		500 mV/g
Acceleration range, VDC > 22 V		10 g peak
Amplitude nonlinearity		1%
Frequency response ¹ :	$\pm 5\%$	0.7 - 5,000 Hz
	$\pm 10\%$	0.5 - 9,000 Hz
	± 3 dB	0.2 - 10,000 Hz
Resonance frequency		30 kHz
Transverse sensitivity, max		5% of axial
Temperature response:	-50°C	-10%
	+120°C	+10%
Power requirement:		
Voltage source		18 - 30 VDC
Current regulating diode		2 - 10 mA
Electrical noise, equiv. g:		
Broadband	2.5 Hz to 25 kHz	250 μ g
Spectral	10 Hz	2.5 μ g/ \sqrt Hz
	100 Hz	1.5 μ g/ \sqrt Hz
	1,000 Hz	1.5 μ g/ \sqrt Hz
Output impedance, max		100 Ω
Bias output voltage		12 VDC
Grounding		case isolated, internally shielded
Temperature range		-50° to +120°C
Vibration limit		500 g peak
Shock limit		5,000 g peak
Electromagnetic sensitivity, equiv. g, max		70 μ g/gauss
Sealing		hermetic
Base strain sensitivity, max		0.0002 g/ μ strain
Sensing element design		PZT, shear
Weight		90 grams
Case material		316L stainless steel
Mounting		1/4-28 UNF tapped hole
Output connector		2 pin, MIL-C-5015 style
Recommended cabling		J10 / J9T2A

Notes: ¹ Frequency response limits, spectral and noise values are typical.

Accessories supplied: SF6 mounting stud; calibration data (level 2)

Certifications

	Class I, Div 2 Groups A, B, C, D		II 3 G	
	Class I, Zone 2		Ex nA IIC T4 Gc	
	AEx/Ex nA II T4			
	Ta = -50°C to 120°C			

Must be installed per 13029. • Ambient temperature range depends on the type cable used during installation. • Cable with FEP jacket, Ta=-50°C to +120°C. • Cable with Santoprene jacket, Ta=-45°C to +115°C.



Key features

- Class I, Div 2/Zone 2 certified - non-incendive
- High sensitivity
- Extended low frequency response
- Manufactured in ISO 9001 facility

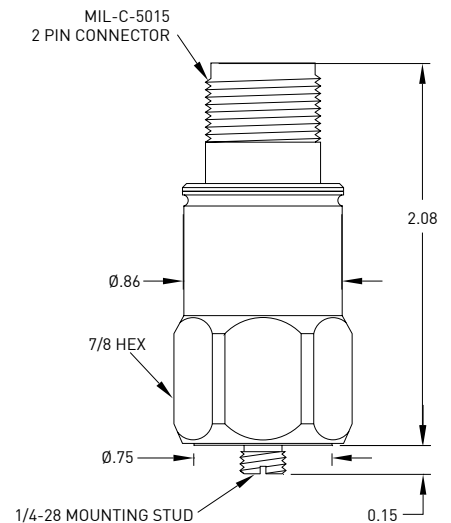

Connections	
Function	Connector pin
power/signal	A
common	B
ground	shell

Note: Due to continuous process improvement, specifications are subject to change without notice. This document is cleared for public release.