

**EPM-7790 72x72 DIN Size**      **Control Panel For V/F Speed Controller**



***EPM-7790 72 x 72 DIN Size  
Control Panel For V/F Speed Controller***

- ***4 Digits Display***
- ***Easily adjustable set value from front panel***
- ***Configurable display scale between -1999 and 9999***
- ***Adjustable decimal point***
- ***Set value low limit and set value high limit boundaries***
- ***Adjustable ramp up and ramp down time***
- ***Forward, Reverse direction outputs and error input for V/F Speed Controller***
- ***0/2...10V  $\overline{\text{---}}$  Voltage output or 0/4...20mA  $\overline{\text{---}}$  Current output (It must be determined in order.)***
- ***Password protection for programming and adjustment sections***

## ABOUT INSTRUCTION MANUAL

Instruction manual of EPM-7790 unit consists of two main sections. Explanation of these sections are below. Also, there are other sections which include order information and technical specifications of the device. All titles and page numbers in instruction manual are in “**CONTENTS**” section. User can reach to any title with section number.

### **Installation:**

In this section, physical dimensions of the device, panel mounting, electrical wiring, physical and electrical installation of the device to the system are explained.

### **Operation and Parameters:**

In this section user interface of the device, accessing to the parameters, description of the parameters are explained.

Also in these sections, there are warnings to prevent serious injury while doing the physical and electrical mounting or using the device.

Explanation of the symbols which are used in these sections are given below.



This symbol is used for safety warnings. User must pay attention to these warnings.



This symbol is used to determine the dangerous situations as a result of an electric shock. User must pay attention to these warnings definitely.



This symbol is used to determine the important notes about functions and usage of the device.

## Contents

<b>1.PREFACE</b> .....	Page	5
1.1 GENERAL SPECIFICATIONS		
1.2 ORDERING INFORMATION		
1.3 WARRANTY		
1.4 MAINTENANCE		
<b>2.INSTALLATION</b> .....	Page	7
2.1 GENERAL DESCRIPTION		
2.2 FRONT VIEW AND DIMENSIONS OF EPM-7790 UNIT		
2.3 PANEL CUT-OUT		
2.4 ENVIRONMENTAL RATING		
2.5 PANEL MOUNTING		
2.6 INSTALLATION FIXING CLAMP		
2.7 REMOVING FROM THE PANEL		
<b>3.ELECTRICAL WIRING</b> .....	Page	12
3.1 TERMINAL LAYOUT AND CONNECTION INSTRUCTIONS		
3.2 ELECTRICAL WIRING DIAGRAM		
3.3 VIEW OF THE DEVICE LABEL		
3.4 SUPPLY VOLTAGE INPUT CONNECTION OF THE DEVICE		
3.5 GALVANIC ISOLATION TEST VALUES OF EPM-7790 UNIT		
3.6 ANALOGUE OUTPUT, DIGITAL INPUT/OUTPUTS CONNECTION WITH V/F SPEED CONTROLLER		
3.6.1 DEVICE WITH (0/2...10V $\rightleftharpoons$ ) ANALOGUE OUTPUT		
3.6.2 DEVICE WITH (0/4...20mA $\rightleftharpoons$ ) ANALOGUE OUTPUT		
<b>4.FRONT PANEL DEFINITION AND ACCESSING TO THE MENUS</b> .....	Page	18
4.1 OBSERVATION OF THE SOFTWARE REVISION ON THE DISPLAY		
4.2 CHANGING AND SAVING SET VALUE		
4.2.1 CHANGING AND SAVING SET VALUE WHILE THE MOTOR IS RUNNING		
4.2.2 CHANGING AND SAVING SET VALUE WHILE THE MOTOR IS NOT RUNNING		
4.3 PROGRAM PARAMETERS		
4.4 EASY ACCESS DIAGRAM OF PROGRAMMING MODE PARAMETERS		
4.5 ENTERING TO THE PROGRAMMING MODE, CHANGING AND SAVING PARAMETER		
4.6 MOTOR START/STOP OPERATION		
<b>5.FAILURE MESSAGE IN EPM-7790 UNIT</b> .....	Page	36
<b>6.SPECIFICATIONS</b> .....	Page	37

## EU DECLARATION OF CONFORMITY

**Manufacturer's Name** : EMKO ELEKTRONIK A.S.  
**Manufacturer's Address** : DOSAB, Karanfil Sk., No:6,  
16369 Bursa, TURKEY

---

The manufacturer hereby declares that the product:

**Product Name** : Control Panel For V/F Speed Controller  
**Type Number** : EPM-7790  
**Product Category** : Electrical equipment for measurement, control and laboratory use

Conforms to the following directives :

2006 / 95 / EC The Low Voltage Directive

2004 / 108 / EC The Electromagnetic Compatibility Directive

has been designed and manufactured to the following specifications:

EN 61000-6-4:2007 EMC Generic Emission Standard for Industrial Environments

EN 61000-6-2:2005 EMC Generic Immunity Standard for Industrial Environments

EN 61010-1:2001 Safety Requirements for electrical equipment for measurement, control and laboratory use

---

### When and Where Issued

16<sup>th</sup> October 2009

Bursa-TURKEY

### Authorized Signature

Name : Serpil YAKIN

Position : Quality Manager

## 1. Preface

EPM-7790 series units are designed for controlling the speed and direction of the motor as a control panel for V/F Speed Controllers in industry. They can be used in many applications with their easy use and operation with their ramp properties.

### 1.1 General Specifications

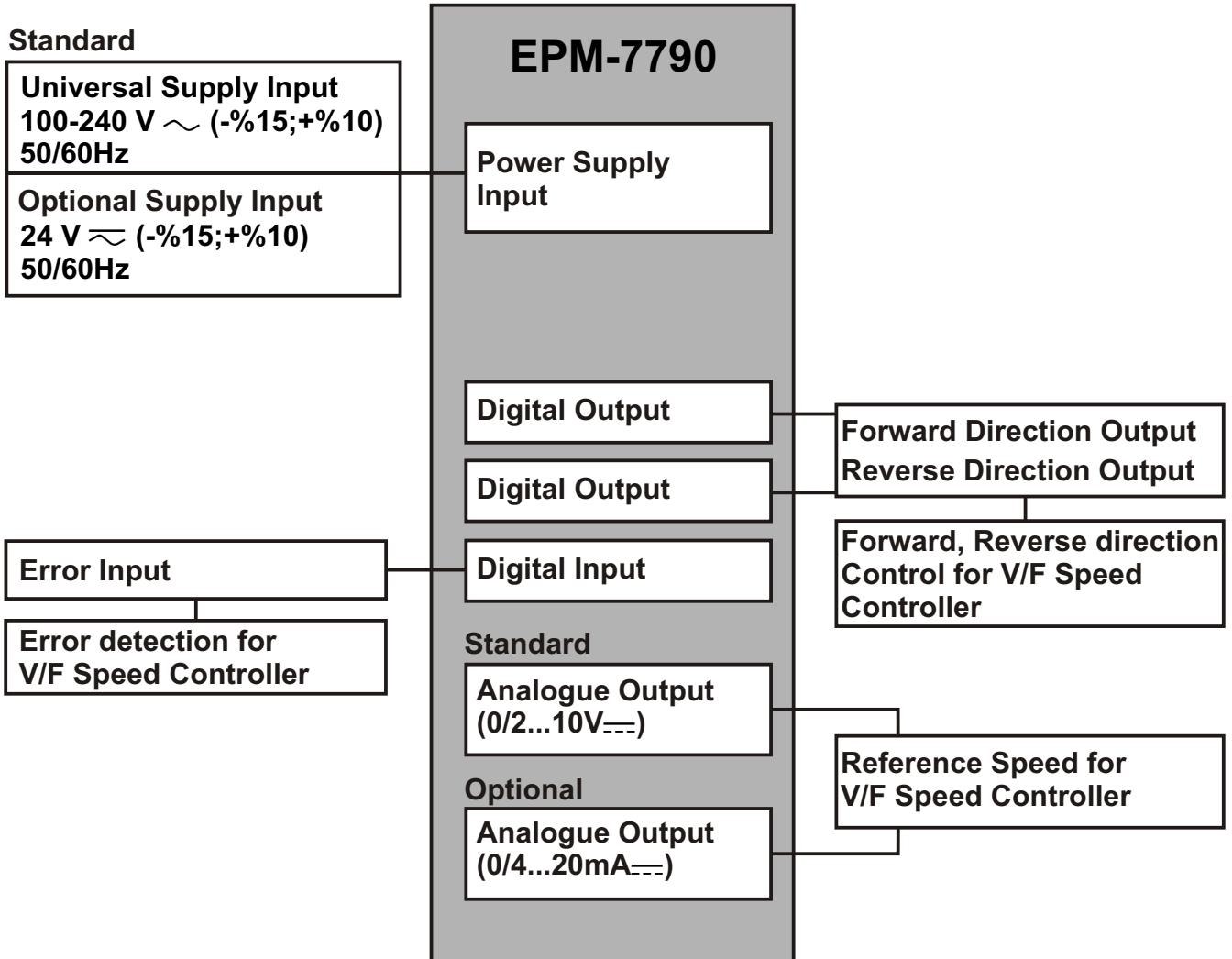

## 1.2 Ordering Information

<b>EPM-7790</b> <small>(72x72 DIN Size)</small>	A	BC	D	E	/	FG	HI	/	U	V	W	Z
		0	0		/	00	00	/	1	0	0	0

A	Power Supply
1	100...240V ~ (- %15;+%10) 50/60Hz
2	24V~(-%15;+%10) 50/60Hz 24V===(-%15;+%10)
9	Customer
E	Output
4	Current Output (0/4...20mA ===)
5	Voltage Output. (0/2...10V === Max. 10mA)

All order information of EPM-7790 units are given on the table at left. User may form appropriate device configuration from information and codes that at the table and convert it to the ordering codes.

Firstly, supply voltage then other specifications must be determined. Please fill the order code blanks according to your needs.

Please contact us, if your needs are out of the standards.



~ Symbol means Vac,  
 === Symbol means Vdc,

## 1.3 Warranty

EMKO Elektronik warrants that the equipment delivered is free from defects in material and workmanship. This warranty is provided for a period of two years. The warranty period starts from the delivery date. This warranty is in force if duty and responsibilities which are determined in warranty document and instruction manual performs by the customer completely.

## 1.4 Maintenance

Repairs should only be performed by trained and specialized personnel. Cut power to the device before accessing internal parts.

Do not clean the case with hydrocarbon-based solvents (Petrol, Trichlorethylene etc.). Use of these solvents can reduce the mechanical reliability of the device. Use a cloth dampened in ethyl alcohol or water to clean the external plastic case.

## 2. Installation



Before beginning installation of this product, please read the instruction manual and warnings below carefully.

In package ,

- One piece unit
- Two pieces mounting clamps
- One piece instruction manual

A visual inspection of this product for possible damage occurred during shipment is recommended before installation. It is your responsibility to ensure that qualified mechanical and electrical technicians install this product.

If there is danger of serious accident resulting from a failure or defect in this unit, power off the system and separate the electrical connection of the device from the system.

The unit is normally supplied without a power supply switch or a fuse. Use power switch and fuse as required.

Be sure to use the rated power supply voltage to protect the unit against damage and to prevent failure.

Keep the power off until all of the wiring is completed so that electric shock and trouble with the unit can be prevented.

Never attempt to disassemble, modify or repair this unit. Tampering with the unit may results in malfunction, electric shock or fire.

Do not use the unit in combustible or explosive gaseous atmospheres.

During the equipment is putted in hole on the metal panel while mechanical installation some metal burrs can cause injury on hands, you must be careful.

Montage of the product on a system must be done with it's fixing clamps. Do not do the montage of the device with inappropriate fixing clamp. Be sure that device will not fall while doing the montage.

It is your responsibility if this equipment is used in a manner not specified in this instruction manual.

## 2.1 General Description

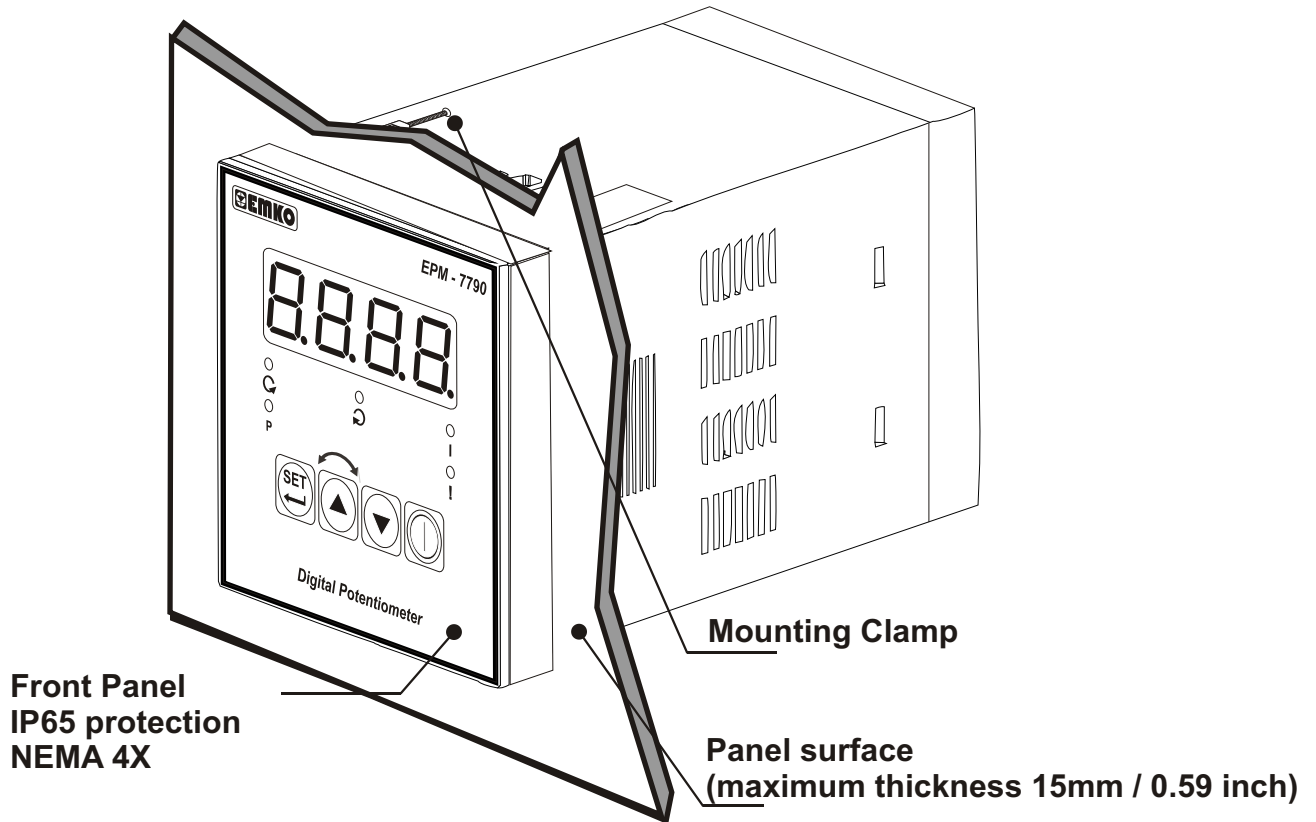

## 2.2 Front View and Dimensions of EPM-7790 Unit

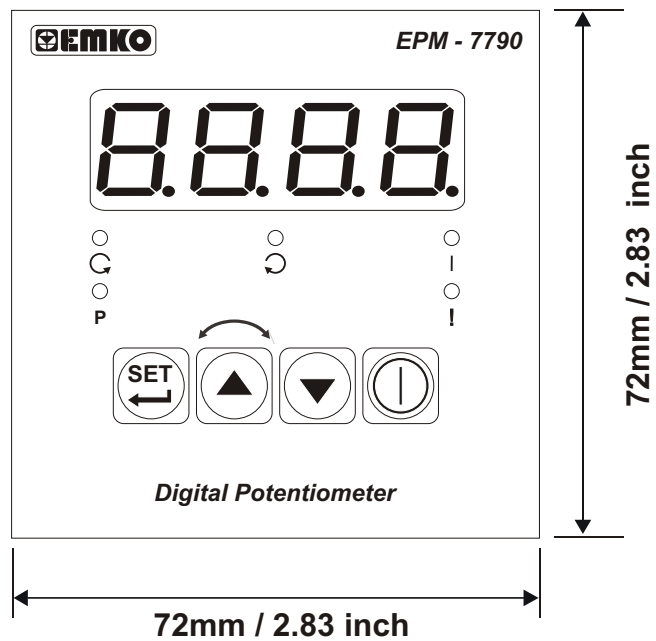



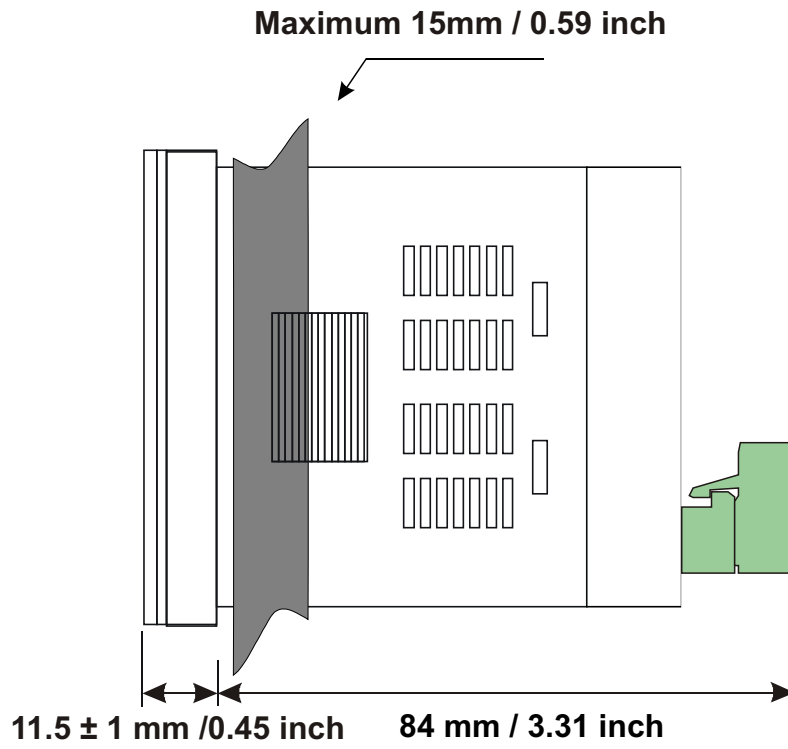

### 2.3 Panel Cut-Out

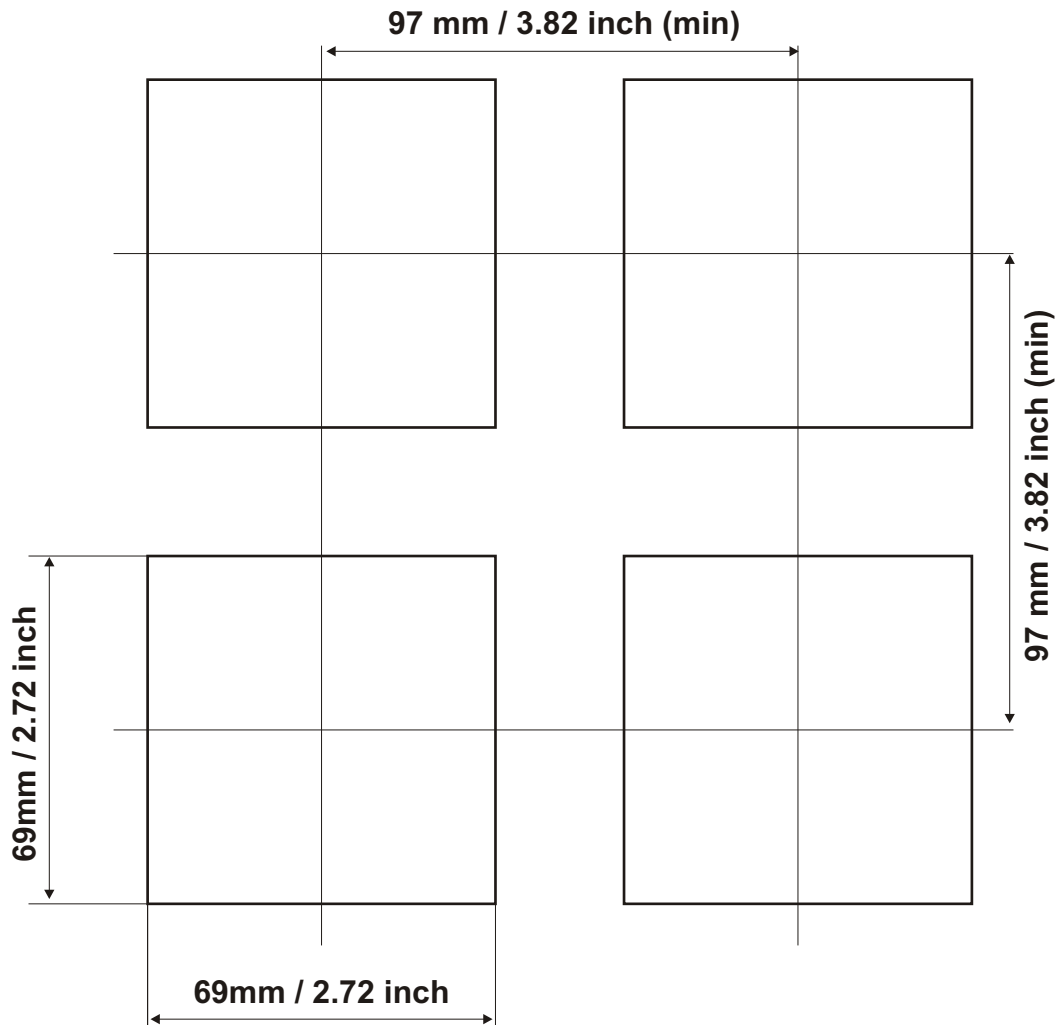

## 2.4 Environmental Ratings

### Operating Conditions



**Operating Temperature** : 0 to 50 °C



**Max. Operating Humidity** : 90% Rh (non-condensing)



**Altitude** : Up to 2000m.



**Forbidden Conditions:**

**Corrosive atmosphere**

**Explosive atmosphere**

**Home applications (The unit is only for industrial applications)**

## 2.5 Panel Mounting

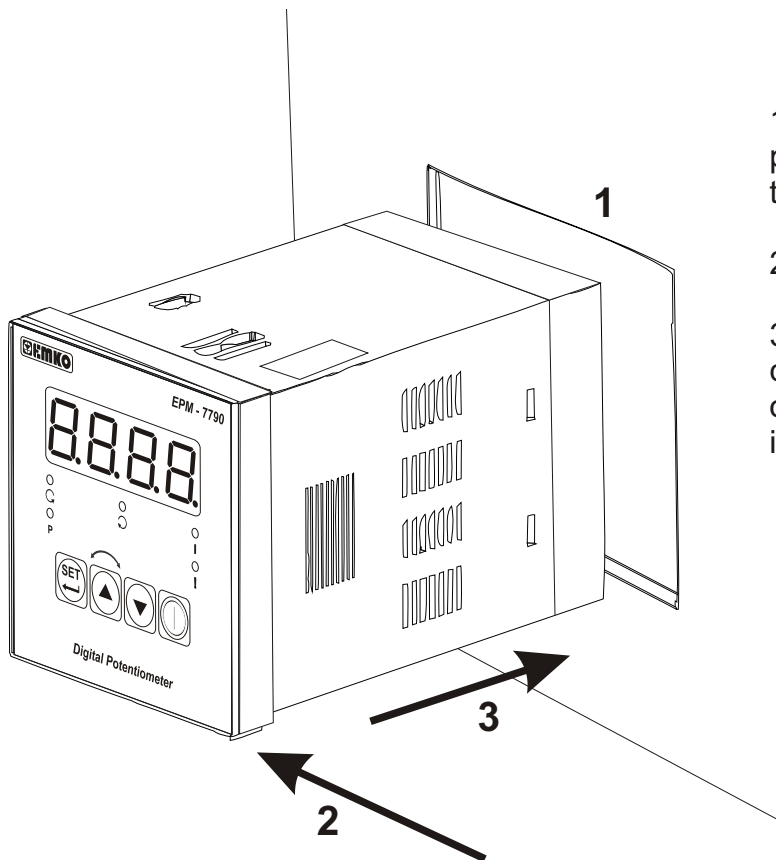

1-Before mounting the device in your panel, make sure that the cut-out is of the right size.

2-Check front panel gasket position

3-Insert the device through the cut-out. If the mounting clamps are on the unit, put out them before inserting the unit to the panel.



During installation into a metal panel, care should be taken to avoid injury from metal burrs which might be present. The equipment can loosen from vibration and become dislodged if installation parts are not properly tightened. These precautions for the safety of the person who does the panel mounting.

## 2.6 Installation Fixing Clamp

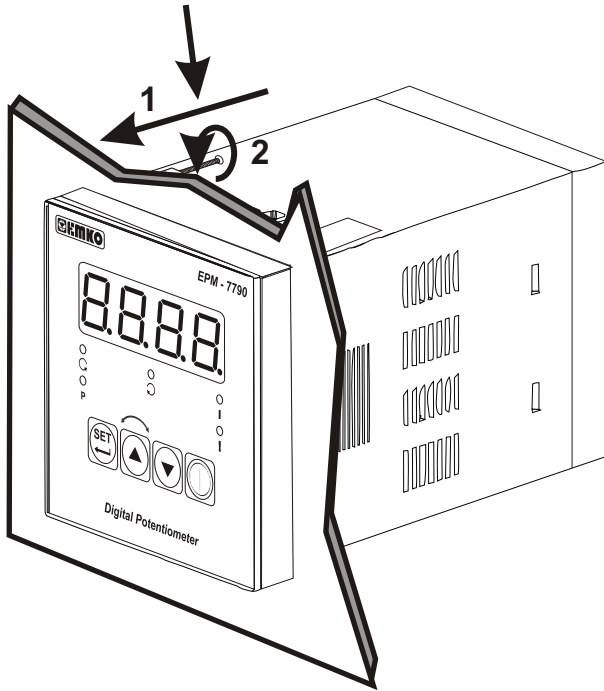

The unit is designed for panel mounting.

1-Insert the unit in the panel cut-out from the front side.

2- Insert the mounting clamps to the holes that located top and bottom sides of device and screw up the fixing screws until the unit completely immobile within the panel



**Montage of the unit to a system must be done with it's own fixing clamps. Do not do the montage of the device with inappropriate fixing clamps. Be sure that device will not fall while doing the montage.**

## 2.7 Removing from the Panel



**Before starting to remove the unit from panel, power off the unit and the related system.**

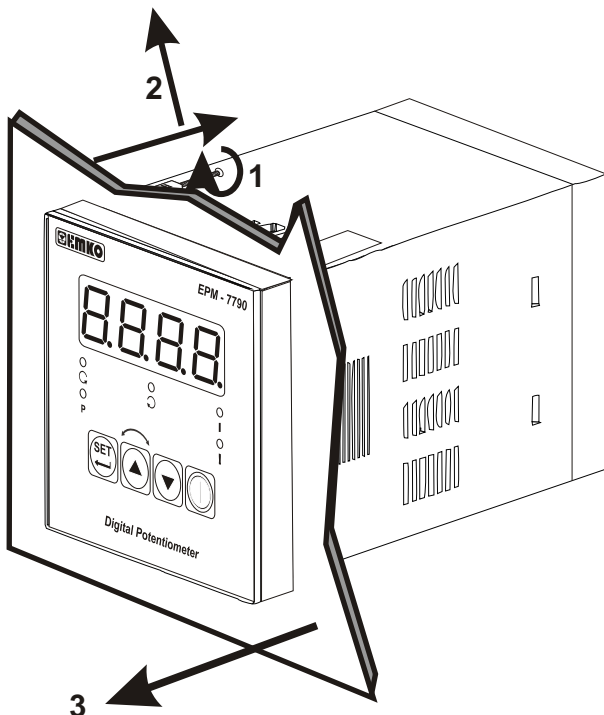

1-Loosen the screws.

2-Pull mounting clamps from top and bottom fixing sockets.

3-Pull the unit through the front side of the panel

### 3. Electrical Wiring



You must ensure that the device is correctly configured for your application. Incorrect configuration could result in damage to the process being controlled, and/or personal injury. It is your responsibility, as the installer, to ensure that the configuration is correct.

Device parameters has factory default values. These parameters must be set according to the system's needs.



Only qualified personnel and technicians should work on this equipment. This equipment contains internal circuits with voltage dangerous to human life. There is severe danger for human life in the case of unauthorized intervention.



Be sure to use the rated power supply voltage to protect the unit against damage and to prevent failure.



Keep the power off until all of the wiring is completed so that electric shock and trouble with the unit can be prevented.

#### 3.1 Terminal Layout and Connection Instructions

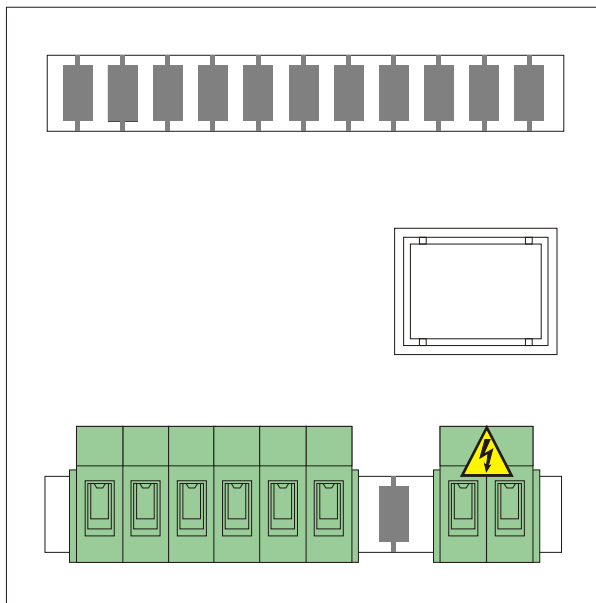

Max. 2.5mm / 0.098 inch  
Wire Size:  
14AWG/1mm<sup>2</sup>  
Solid /Stranded

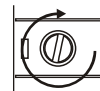

Torque  
0.5 Nm



Screw driver  
0.8x3mm

### 3.2 Electrical Wiring Diagram



Electrical wiring of the device must be the same as 'Electrical Wiring Diagram' below to prevent damage to the process being controlled and personnel injury.

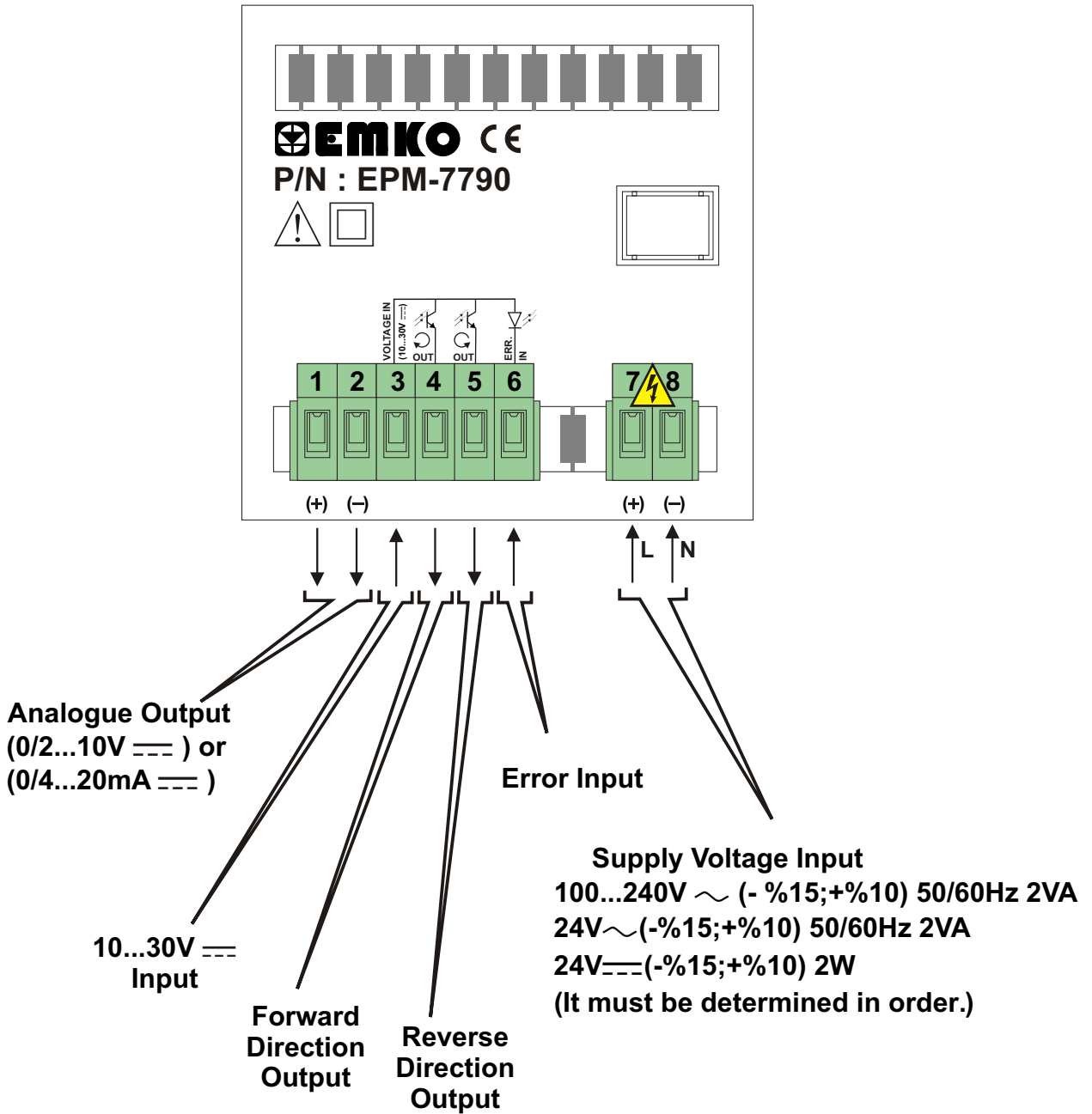

### 3.3 View of the Device Label

Device Label for (0/2...10V  $\overline{\text{---}}$ )  
Output and 100-240V  $\sim$  Supply  
Voltage Input

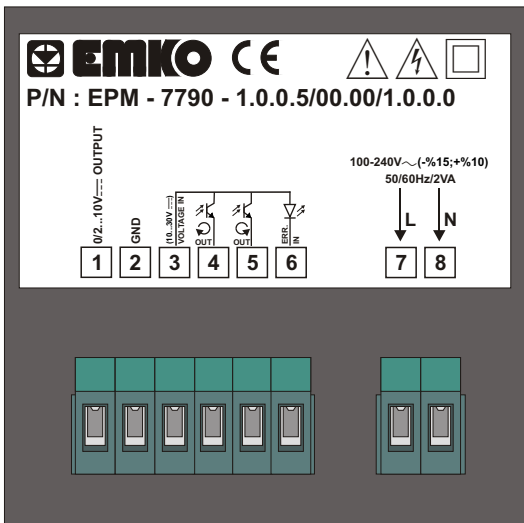

Device Label for (0/4...20mA  $\overline{\text{---}}$ )  
Output and 100-240V  $\sim$  Supply  
Voltage Input

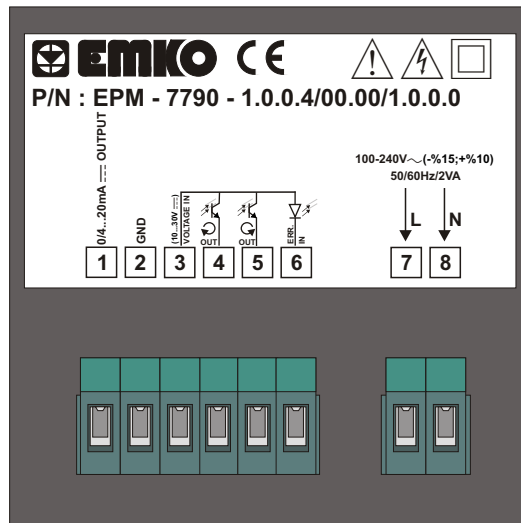

Device Label for (0/2...10V  $\overline{\text{---}}$ )  
Output and 24V  $\overline{\sim}$  Supply  
Voltage Input

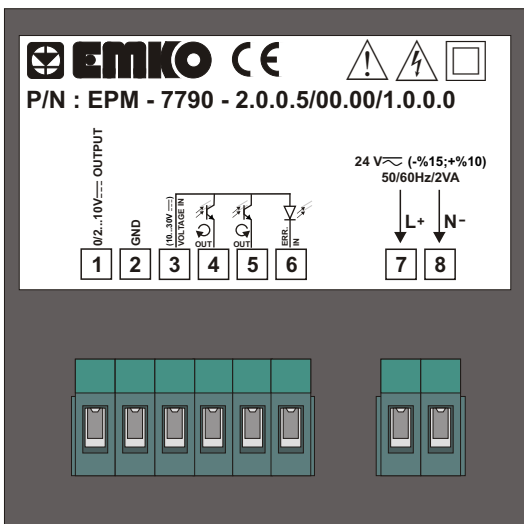

Device Label for (0/4...20mA  $\overline{\text{---}}$ )  
Output and 24V  $\overline{\sim}$  Supply  
Voltage Input

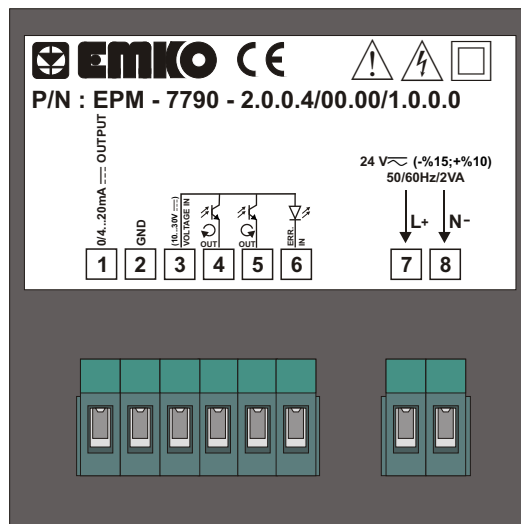

### 3.4 Supply Voltage Input Connection of the Device

#### Connection of Supply Voltage Input

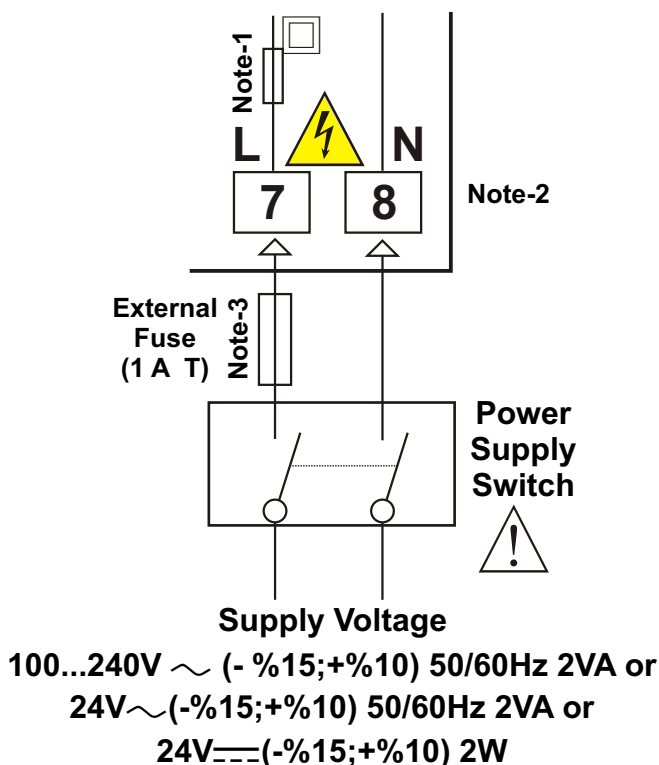

**Note-1 :** There is an internal 33R fusible flameproof resistor in 100-240 V  $\sim$  50/60Hz  
 There is an internal 4R7 fusible flameproof resistor in 24V  $\sim$  50/60Hz

**Note-2:** “L” is (+), “N” is (-) for 24V === Supply Voltage

**Note-3:** External Fuse is recommended



**Make sure that the power supply voltage is same indicated on the instrument. Switch on the power supply only after that all the electrical connection have been completed.**

**Supply voltage range must be determined in order. While installing the unit, supply voltage range must be controlled and appropriate supply voltage must be applied to the unit. Controlling prevents damages in unit and system and possible accidents as a result of incorrect supply voltage.**



**There is no power supply switch or fuse on the device. So a power supply switch and a fuse must be added to the supply voltage input. Power supply switch and fuse must be put to a place where user can reach easily.**

**Power supply switch must be two poled for seperating phase and neutral. On/Off condition of power supply switch is very important in electrical connection. On/Off condition of power supply switch must be signed for preventing the wrong connection.**

**External fuse must be on phase connection in  $\sim$  supply input.**

**External fuse must be on (+) line connection in === supply input.**



**The instrument is protected with an internal fuse (Please refer to Note-1 for information). In case of failure it is suggested to return the instrument to the manufacturer for repair.**

### 3.5 Galvanic Isolation Test Values of EPM-7790 Unit

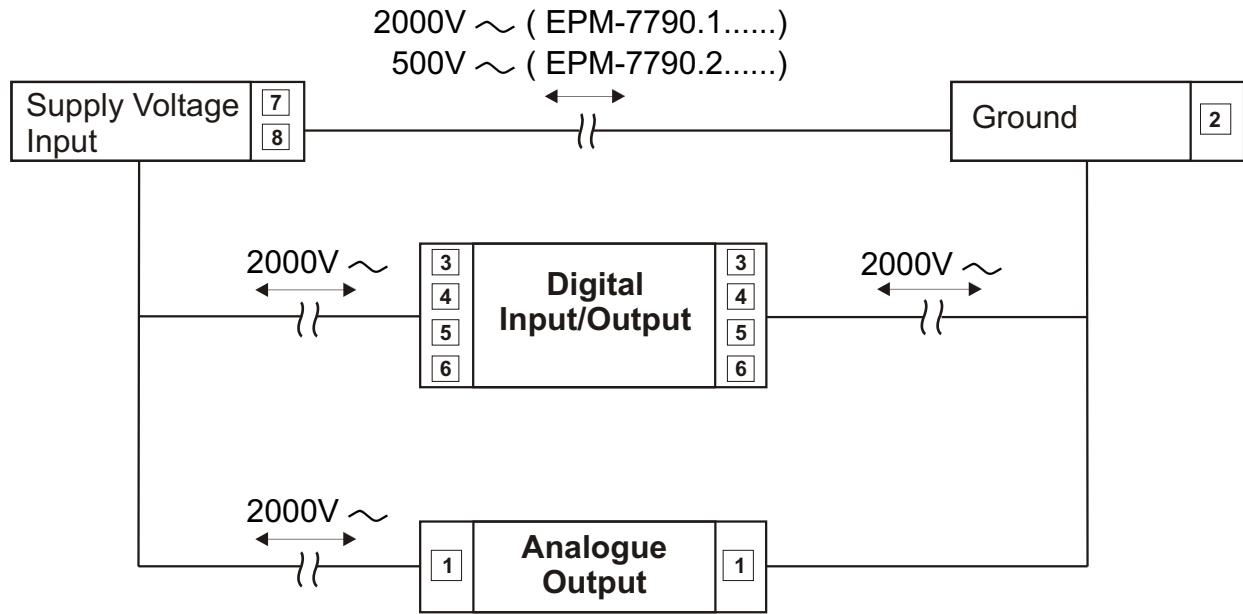



### 3.6 Analogue Output, Digital Input/Outputs Connection with V/F Speed Controller

#### 3.6.1 Devices with (0/2...10V $\overline{\text{---}}$ ) Analogue Output

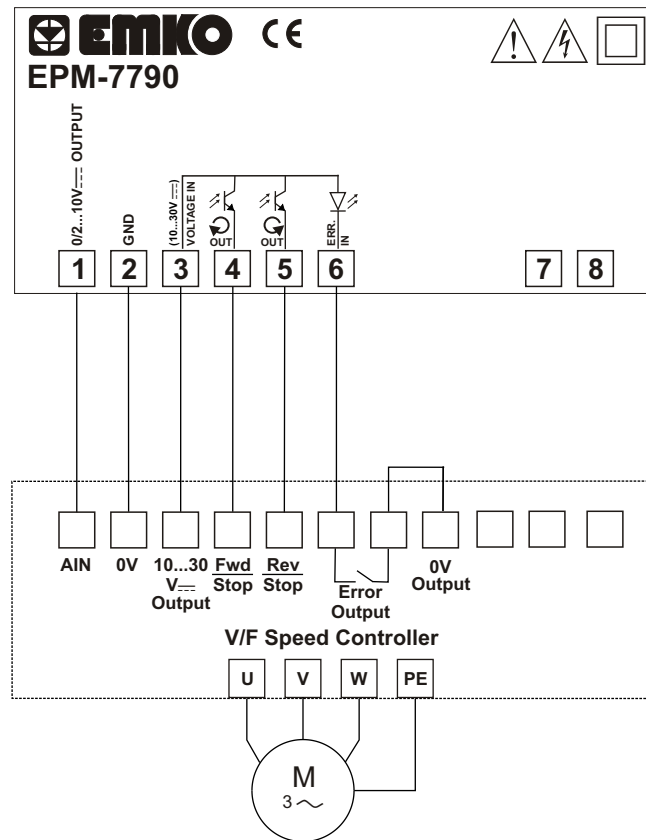

#### 3.6.2 Devices with (0/4...20mA $\overline{\text{---}}$ ) Analogue Output

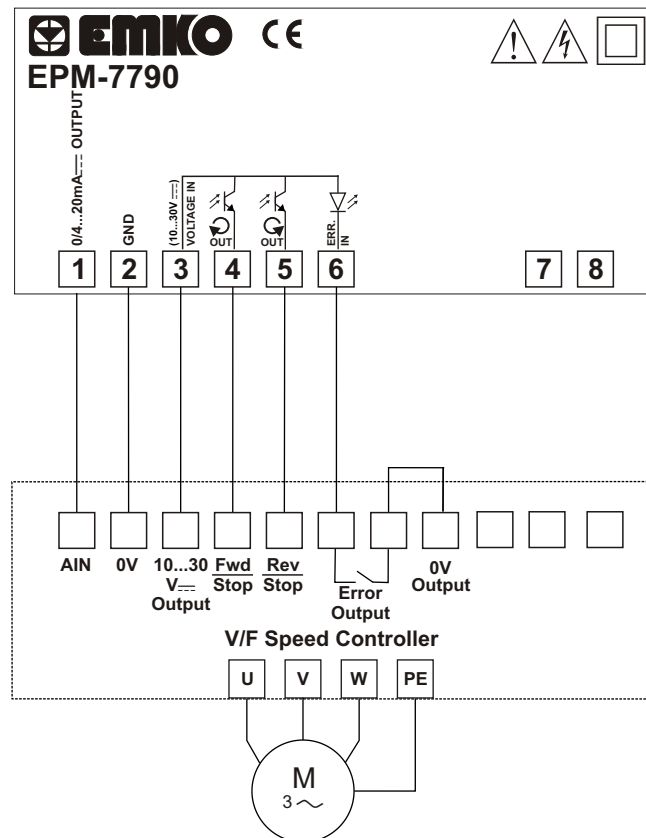

## 4. Front Panel Definition and Accessing to the Menu

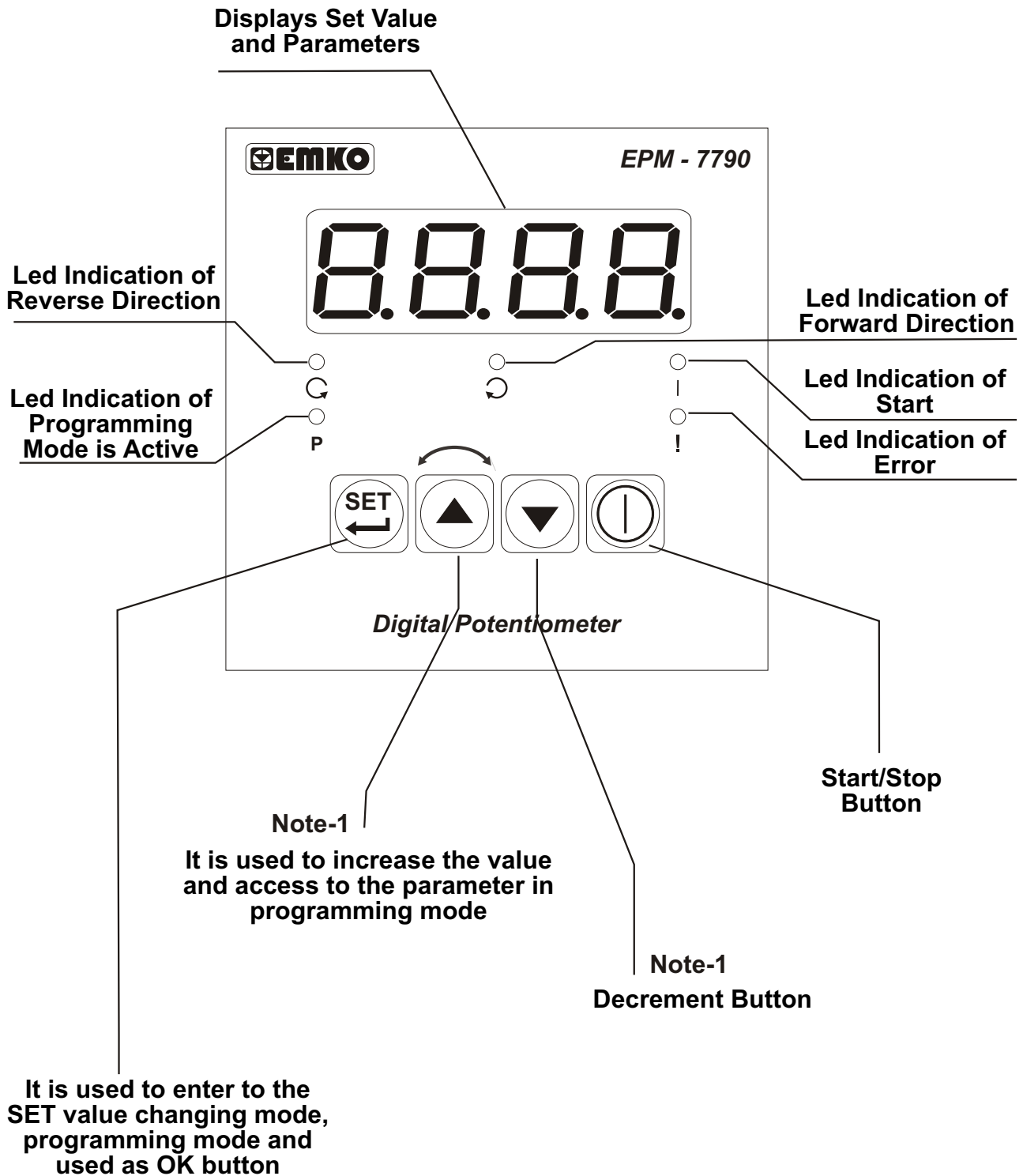

**Note-1:** If increment or decrement button is pressed for 2 seconds continuously, increment and decrement number become 10, if pressed for 4 seconds continuously, increment and decrement number become 100, if pressed for 6 seconds continuously, increment and decrement number become 1000.

## 4.1 Observation of Software Revision on the Display

When power is first applied to the digital potentiometer, software revision number is shown on the display.

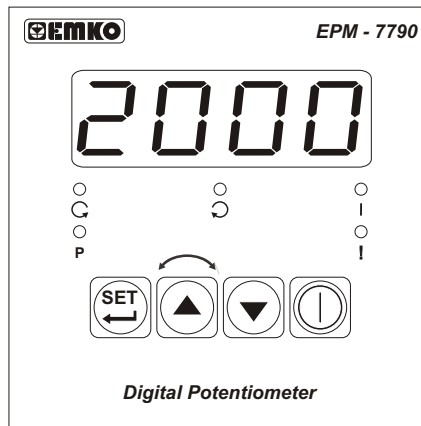
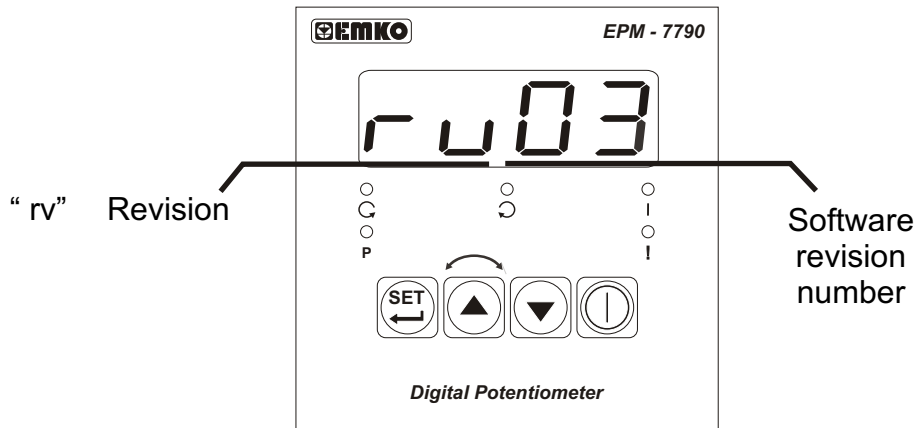

Operation Screen is shown



If there is an unexpected situation while opening the device, power off the device and inform a qualified personnel.

## 4.2 Changing and Saving Set Value

### 4.2.1 Changing and Saving Set Value While The Motor is Running

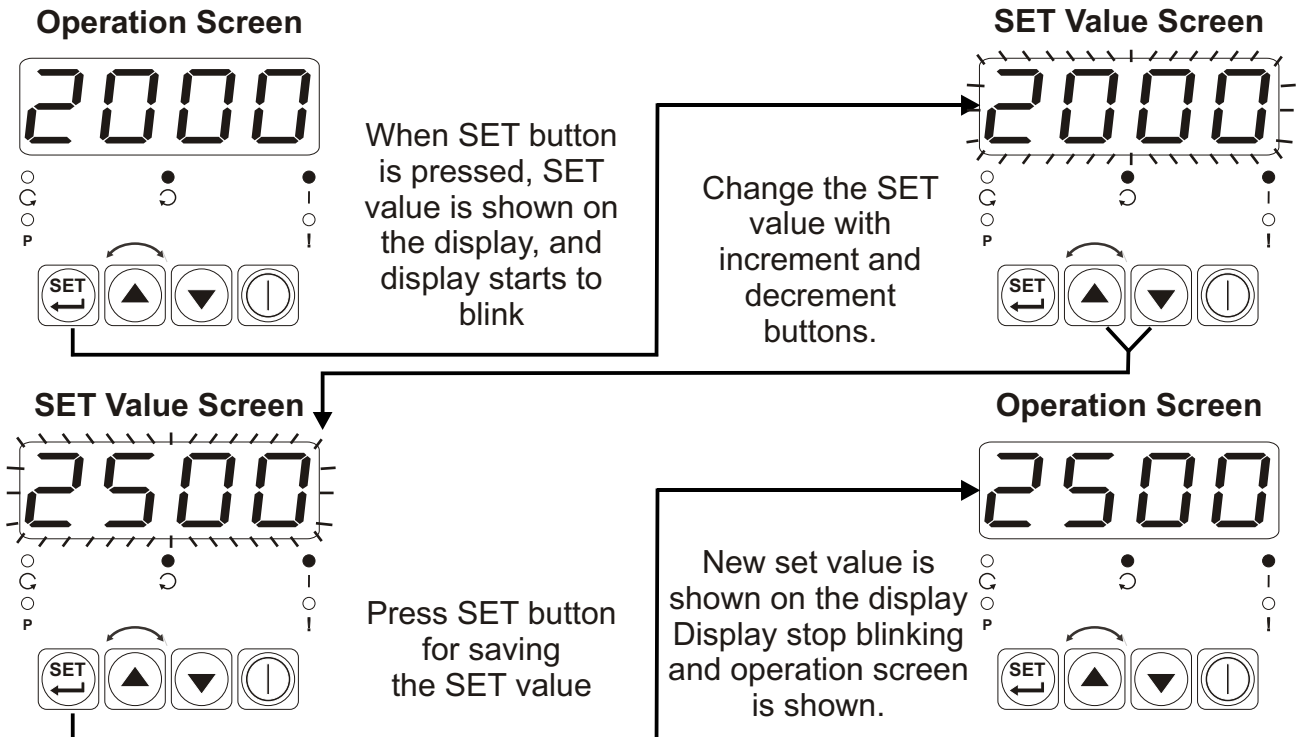

If Set value is changed while the motor is running, analogue output is affected simultaneously by change on the set value. Analogue output is increase or decrease to the new value according to the `rvt` and `rdt` parameters.

### 4.2.2 Changing and Saving Set Value While The Motor is not Running

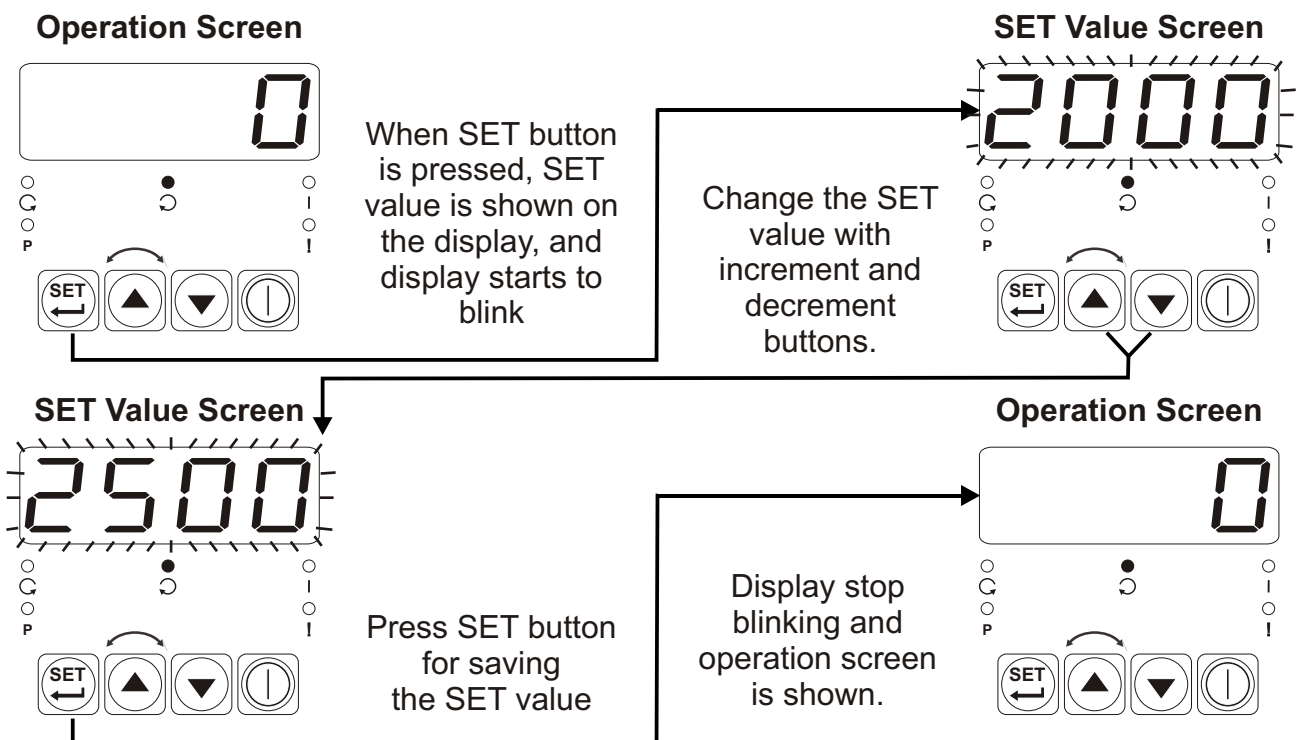

SET Value can be adjusted from minimum set value `SU-L` parameter to maximum set value `SU-U` parameter, they can be accessed from programming parameters.



If no operation is performed in Set value changing mode for 20 seconds, device turns to operation screen automatically.

### 4.3. Program Parameters

**LoL**

#### Scale Low Limit Parameter ( Default = 0 )

It can be adjusted from -1999 to ( **uPL** -1). At this value analogue output becomes;

If **oRt** =0, according to the device type 0V<sup>(1)</sup> or 0mA<sup>(2)</sup>

If **oRt** =1, according to the device type 2V<sup>(1)</sup> or 4mA<sup>(2)</sup>

**uPL**

#### Scale High Limit Parameter:( Default = 4000 )

It can be adjusted from ( **LoL** +1) to 9999. At this value analogue output becomes;

According to the device type 10V<sup>(1)</sup> or 20mA<sup>(2)</sup>

**Su-L**

#### Set Low Limit Parameter:( Default = 0 )

Set value can not be defined less than this value.

It can be adjusted from Scale low limit parameter **LoL** value to Set high limit parameter **Su-U** value.

**Su-U**

#### Set High Limit Parameter:( Default = 4000 )

Set value can not be defined greater than this value.

It can be adjusted from Set low limit parameter **Su-L** value to Scale high limit parameter **uPL** value.

**dpnt**

#### Decimal Point Position Parameter:( Default = 0 )

Decimal point position is determined with this parameter. It can be adjusted from 0 to 3.

**Strt**

#### Power On Output Control Parameter: ( Default = 3 )

When power on firstly, Analogue and digital outputs status can be determined with this parameter. It can be adjusted from 0 to 3.

**Strt** =  Motor doesn't starts to operate, Analogue output is equal to the Set low limit value.

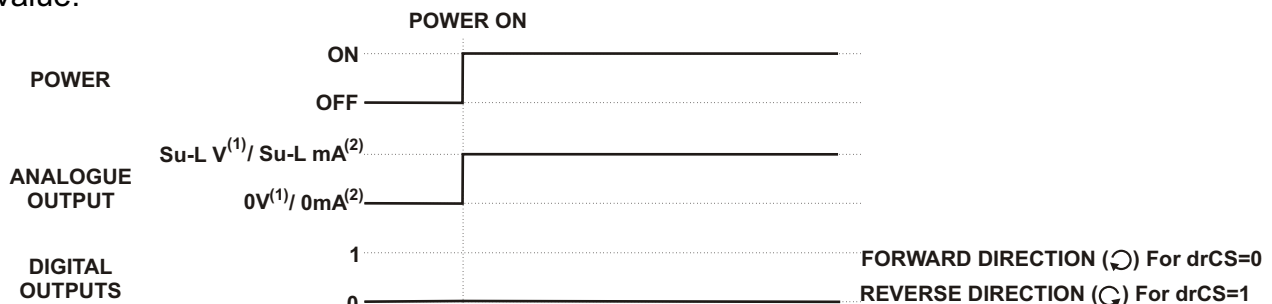

Figure-4.1 Power On Behaviour (Strt=0)

**Strt** =  Motor starts to operate, Analogue output is equal to the Set low limit value

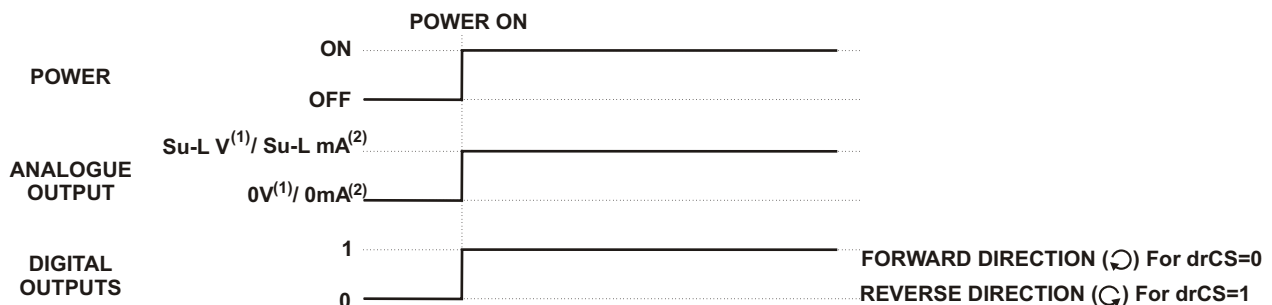

Figure-4.2 Power On Behaviour (Strt=1)



(1) It is valid, if the device type 0/2...10V<sub>---</sub> analogue output.

(2) It is valid, if the device type 0/4...20mA<sub>---</sub> analogue output.

Strt = 2 Motor starts to operate, Analogue output is equal to the Set value

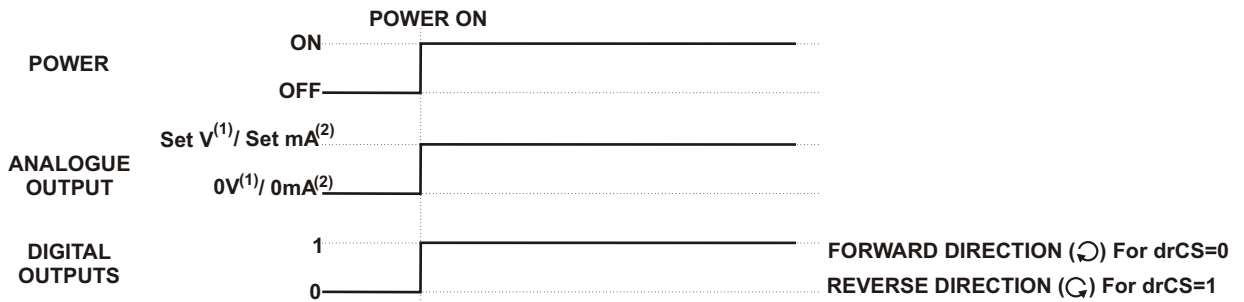

Figure-4.3 Power On Behaviour (Strt=2)

Strt = 3 Motor starts to operate, Analogue output is increase from the Scale low limit to Set value according to the ramp up time.

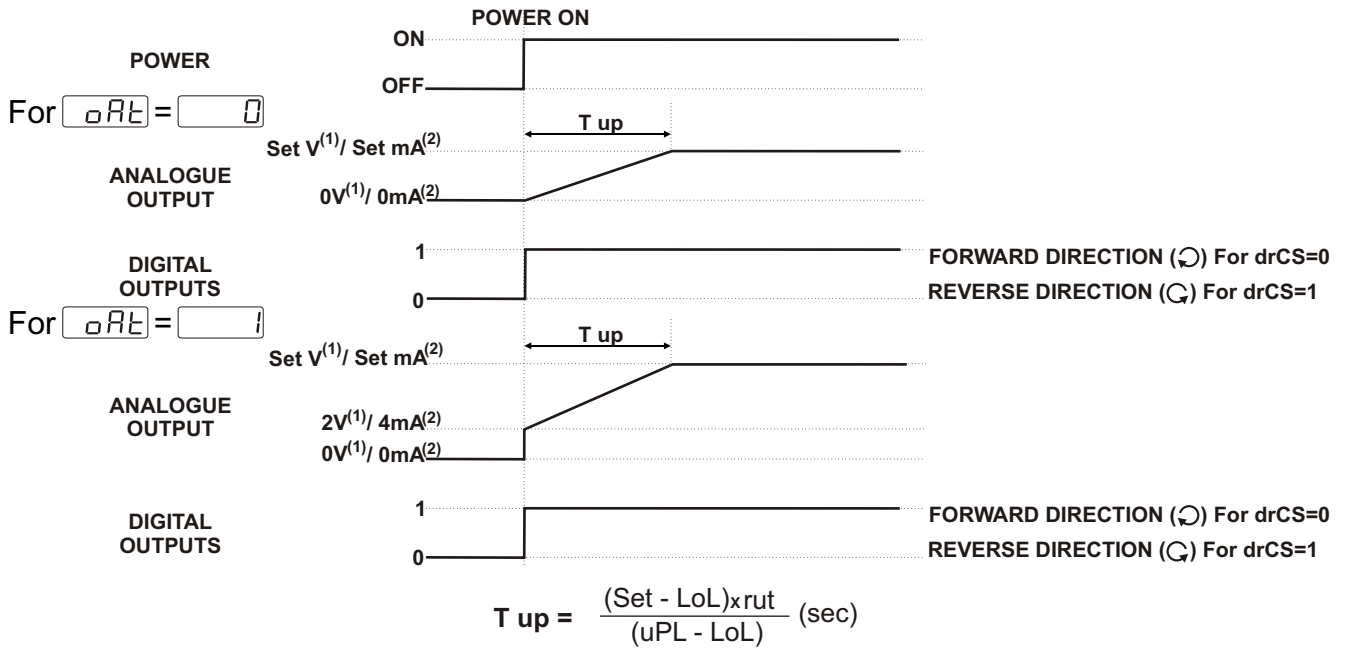

Figure-4.4 Power On Behaviour (Strt=3)

drCS

**Direction Selection:( Default = 0 )**

Direction of the movement is determined with this parameter.

- Forward Direction (D)
- Reverse Direction (G)

drCt

**Direction Change Delay Time Parameter:( Default = 200msec )**

In direction changes, when motor stopped, this time must be expire to operate again in other direction. It can be adjusted from 1 to 9999msec. (Please refer to Figure 4.6 for detail information )

rut

**Ramp Up Time Parameter:( Default = 10sec )**

Increasing time of the analogue output from 0V <sup>(1)</sup> value to 10V <sup>(1)</sup> value or from 0mA <sup>(2)</sup> value to 20mA <sup>(2)</sup> value is determined with this parameter. It can be adjusted from 1 to 999sec.

rdt

**Ramp Down Time Parameter:( Default = 10sec )**

Decreasing time of the analogue output from 10V <sup>(1)</sup> value to 0V <sup>(1)</sup> value or from 20mA <sup>(2)</sup> value to 0mA <sup>(2)</sup> value is determined with this parameter. It can be adjusted from 1 to 999sec.



- (1) It is valid, if the device type 0/2...10V<sub>---</sub> analogue output.
- (2) It is valid, if the device type 0/4...20mA<sub>---</sub> analogue output.

1bLn

### Increment Button Parameter for Functional Usage :( Default = 3)

Usage of the Increment button While the motor is running and the unit is on operation screen

- 0 Increment button is disable
- 1 Analogue output is directly adjusted to Set value when increment button is pressed.
- 2 Analogue output is increased to Set value according to the ramp up time when increment button is pressed.
- 3 Direction of the movement is changed when increment button is pressed.

dbLn

### Decrement Button Parameter for Functional Usage:( Default = 2)

Usage of the Decrement button While the motor is running and the unit is on operation screen

- 0 Decrement button is disabled
- 1 Analogue output is directly adjusted to minimum Set value when decrement button is pressed.
- 2 Analogue output is decreased to minimum Set value according to the ramp down time when decrement button is pressed.

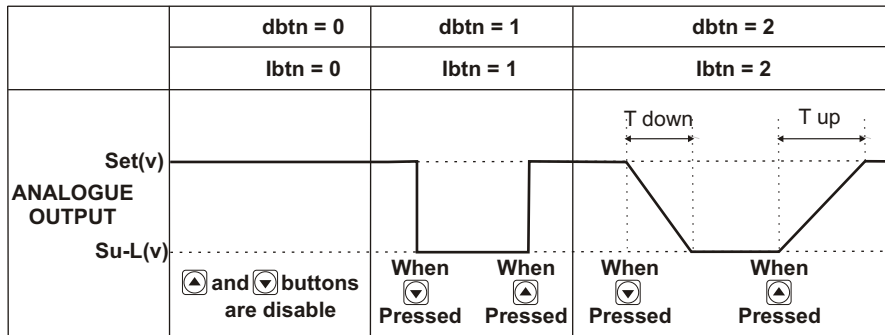

Figure-4.5 Increment and Decrement Button Functional Usage

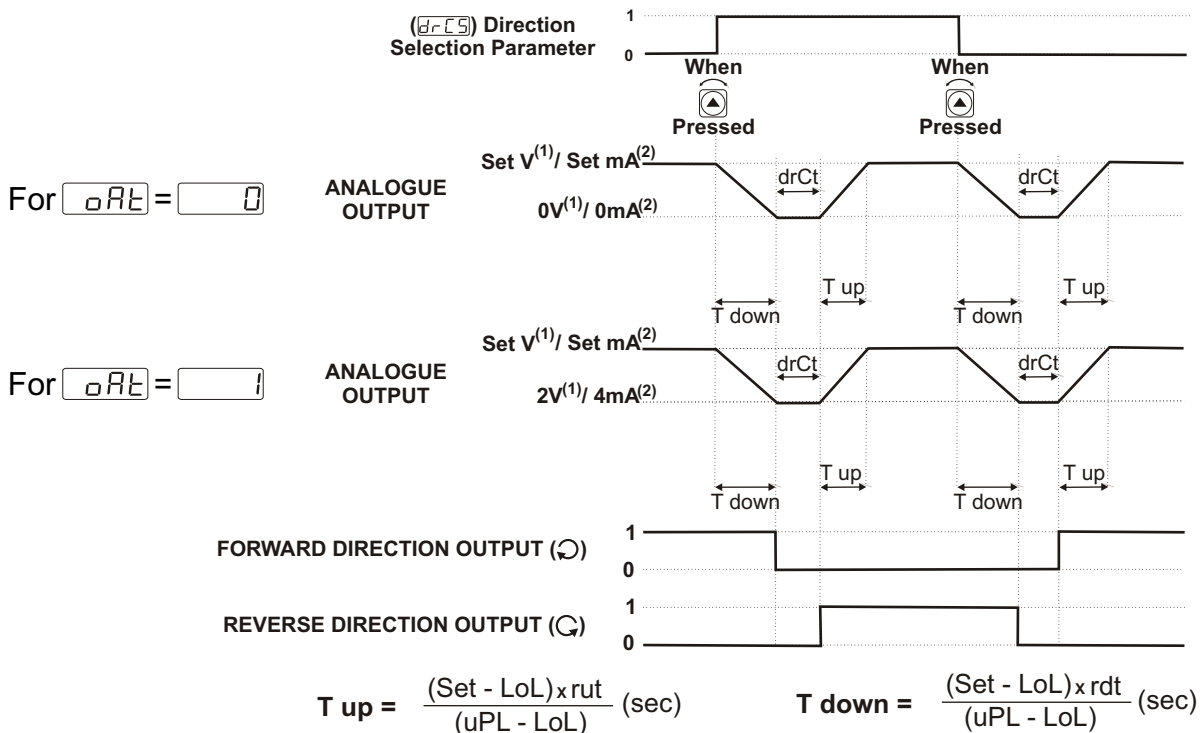

Figure-4.6 Motor Direction Change (lbtn=3)



- (1) It is valid, if the device type 0/2...10V== analogue output.
- (2) It is valid, if the device type 0/4...20mA== analogue output.

5 Idt

### Set Changing Value Parameter:( Default = 3 )

Changing value for Set value is determined with this parameter.

0001

Set changing value become one(1)

0002

Set changing value become ten(10)

0003

Set changing value become hundred(100), for each pressing the Increment, Decrement button

0004

Set changing value become incremental. (Note-1)

oAL

### Analogue Output Range Selection Parameter:( Default = 0 )

Analogue output range is determined with this parameter

0

according to the device type 0...10V<sup>(1)</sup> or 0...20mA<sup>(2)</sup>

1

according to the device type 2...10V<sup>(1)</sup> or 4...20mA<sup>(2)</sup>

APAS

### Adjustment Section Accessing Password:

Required password is entered via this parameter for accessing to the adjustment section. If the parameter value is entered as 3083, **AUAL** screen is accessed, otherwise **PASS** parameter is seen

AUAL

### Adjustment Value Parameter:

Adjustment value for Analogue output. It can be adjusted from 0 to 4095.

When pressing  button on **AUAL** screen, adjustment value is seen on screen. The value on the screen should be adjusted with Increment and decrement button until 10.00V<sup>(1)</sup> or 20.00mA<sup>(2)</sup> is obtained from the analogue output.

After getting the 10.00V<sup>(1)</sup> or 20.00mA<sup>(2)</sup> on analogue output, press  button for saving this value as an adjustment value

PASS

### Programming Section Accessing Password:( Default = 0 )

It is used for entering to the programming section.

It can be adjusted from 0 to 9999. If this password is 0, programming section can be accessed without entering the password.

**Note-1:** If increment or decrement button is pressed for 2 seconds continuously, increment and decrement number become 10, if pressed for 4 seconds continuously, increment and decrement number become 100, if pressed for 6 seconds continuously, increment and decrement number become 1000.



(1) It is valid, if the device type 0/2...10V<sub>---</sub> analogue output.

(2) It is valid, if the device type 0/4...20mA<sub>---</sub> analogue output.



## 4.4 Easy Access Diagram Of Programming Mode Parameters

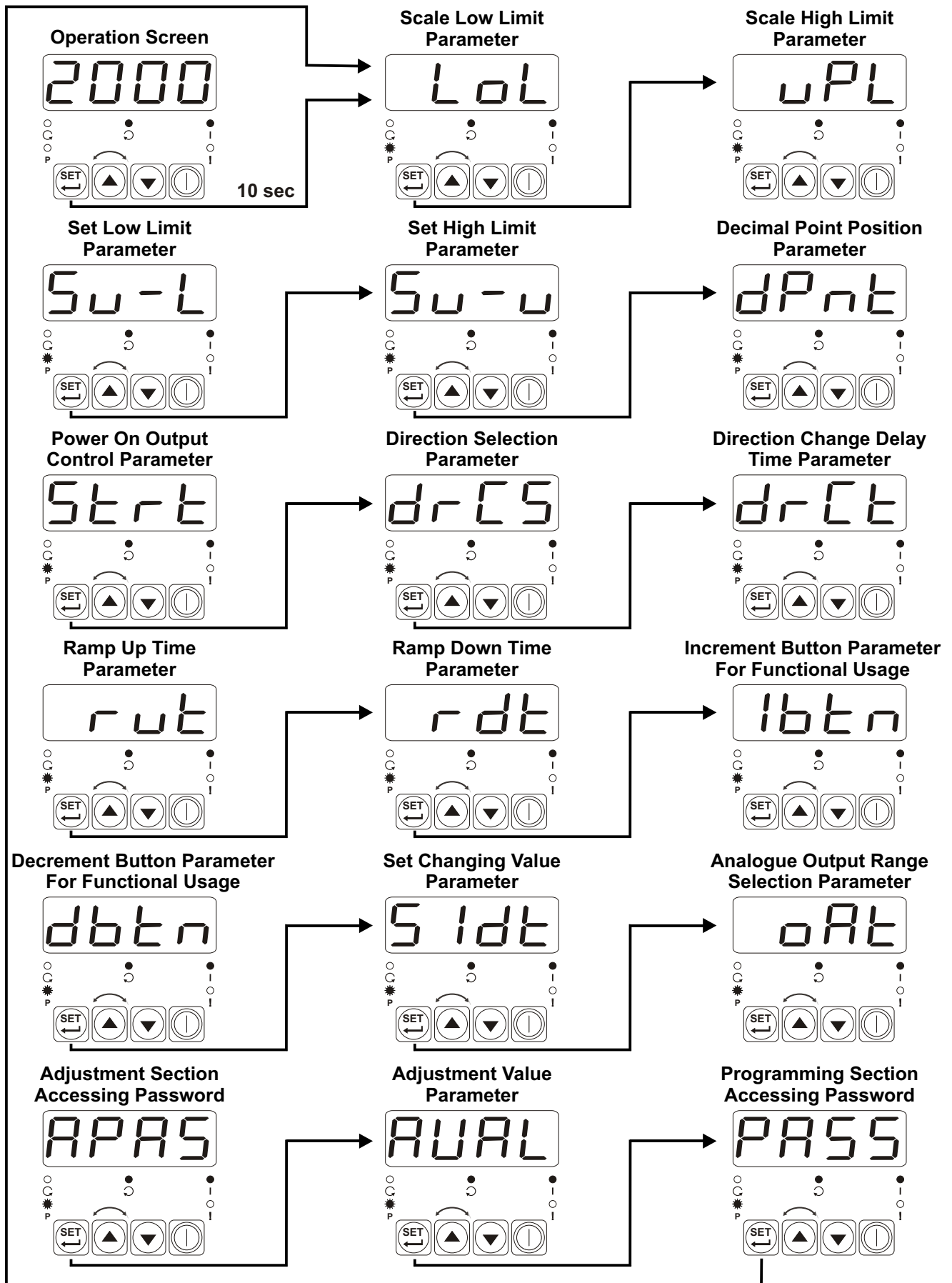

If no operation is performed in Programming mode for 20 seconds, device turns to operation screen automatically

## 4.5 Entering To The Programming Mode, Changing and Saving Parameter

### Operation Screen

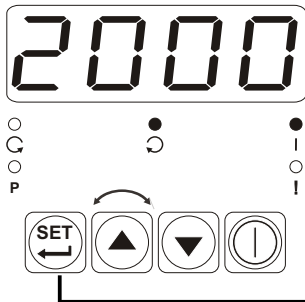

When SET button is pressed for 10seconds, "P" led starts to blink. If programming section accessing password is different from 0, programming section accessing screen **PASS** is observed

### Programming Section Accessing Screen

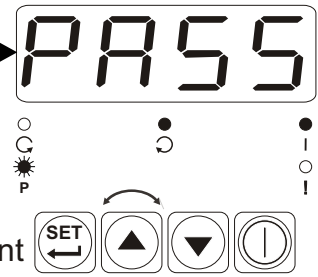

Press increment button for accessing to the password entering screen

### Password Entering Screen

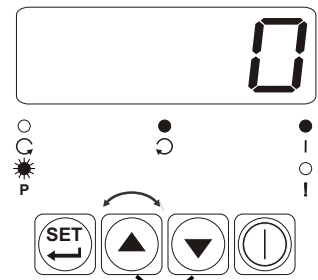

Enter programming section accessing password with Increment and decrement buttons

**Note-1:** If programming section accessing password is 0, scale low limit parameter screen **L0L** is observed instead of programming section accessing screen **PASS**

**Note-2:** Parameters can be observed by pressing SET button in programming section accessing screen without entering programming section accessing password. But parameters can not be changed.

### Password Entering Screen

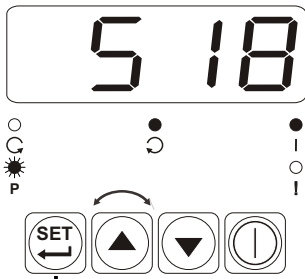

Press Set button for accessing to the parameters

### Scale Low Limit Parameter

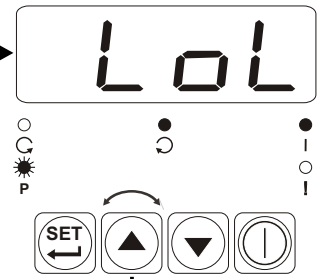

Parameter is accessed by pressing increment button. If set button is pressed, next parameter is shown.

### Scale Low Limit Parameter Value

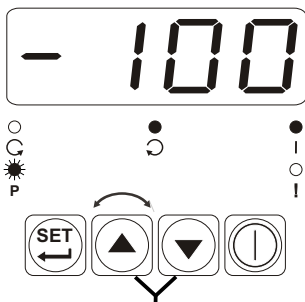

Change the value with increment and decrement buttons

### Scale Low Limit Parameter Value

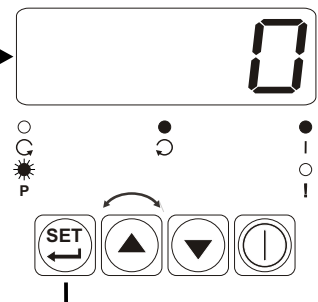

Press Set button for saving the parameter value



If no operation is performed in Programming mode for 20 seconds, device turns to operation screen automatically.

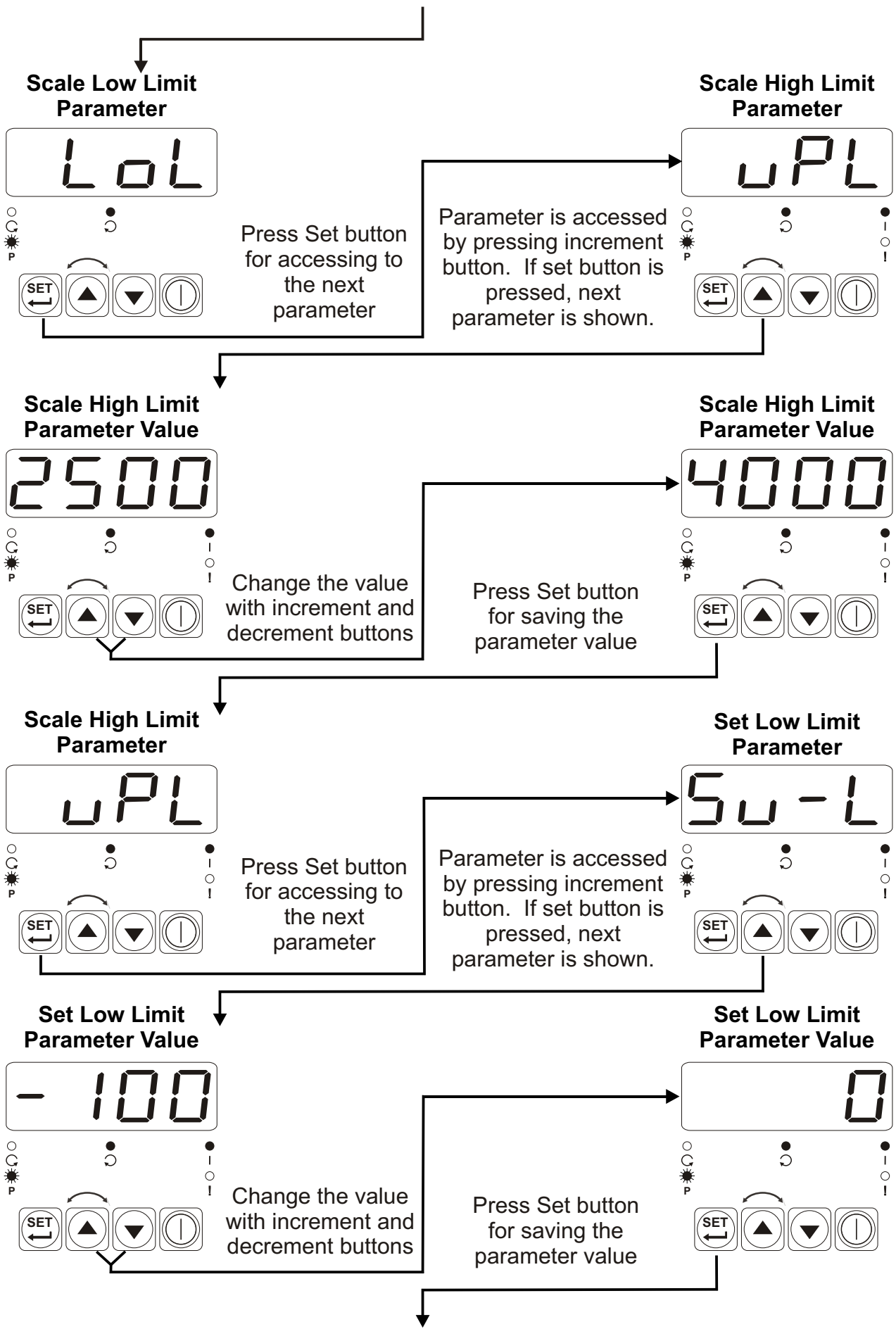

If no operation is performed in Programming mode for 20 seconds, device turns to operation screen automatically.

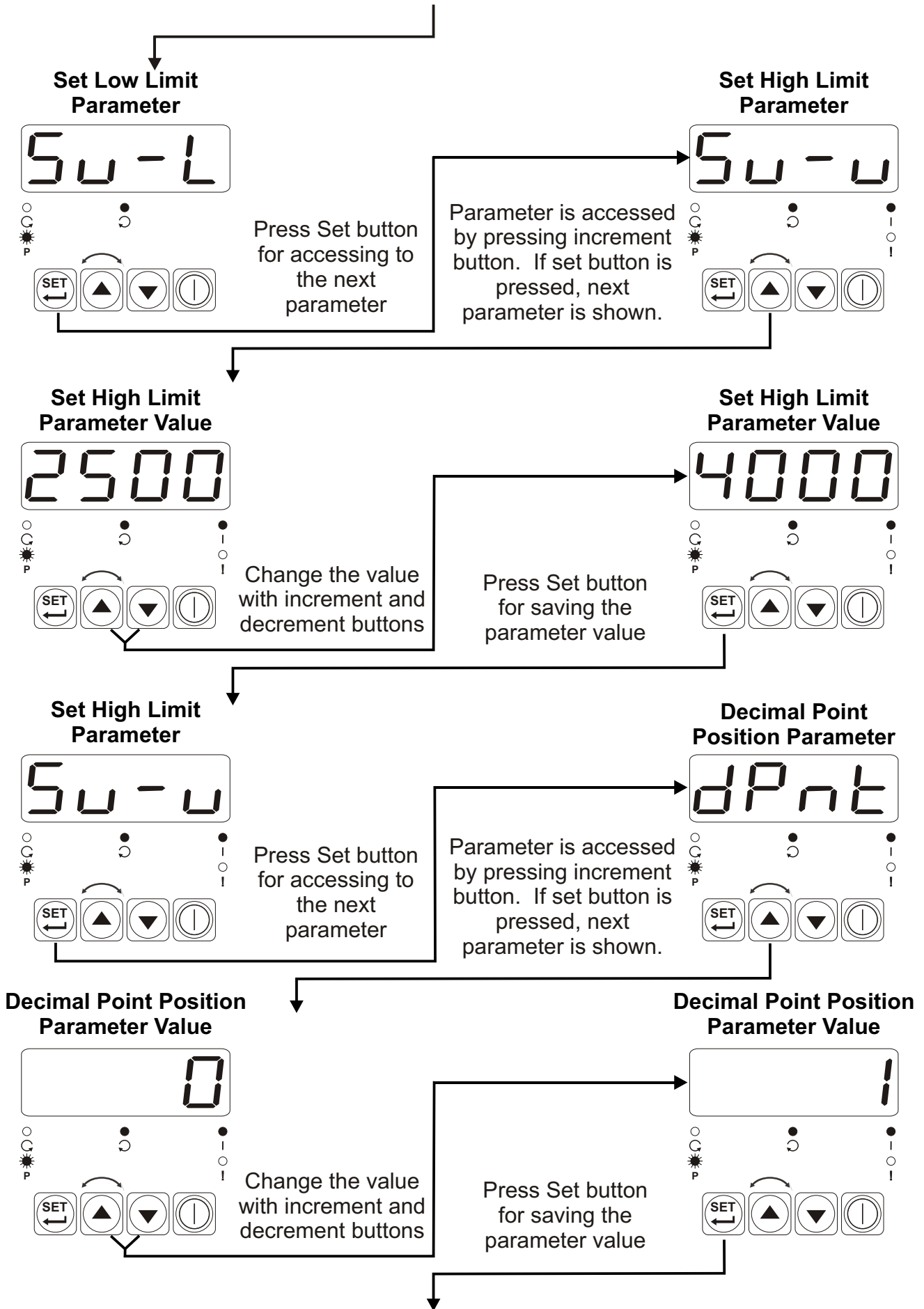

If no operation is performed in Programming mode for 20 seconds, device turns to operation screen automatically.

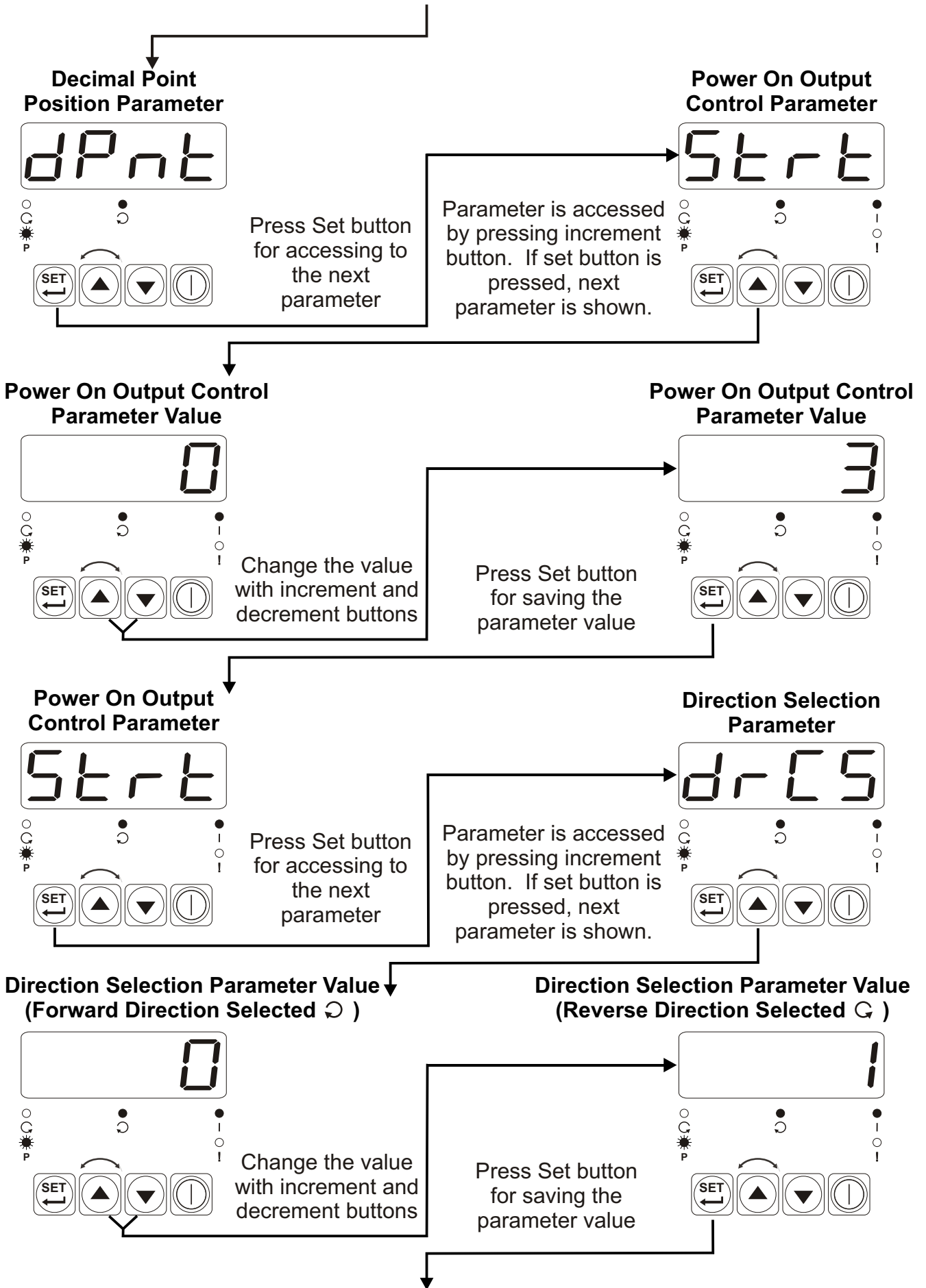

If no operation is performed in Programming mode for 20 seconds, device turns to operation screen automatically.

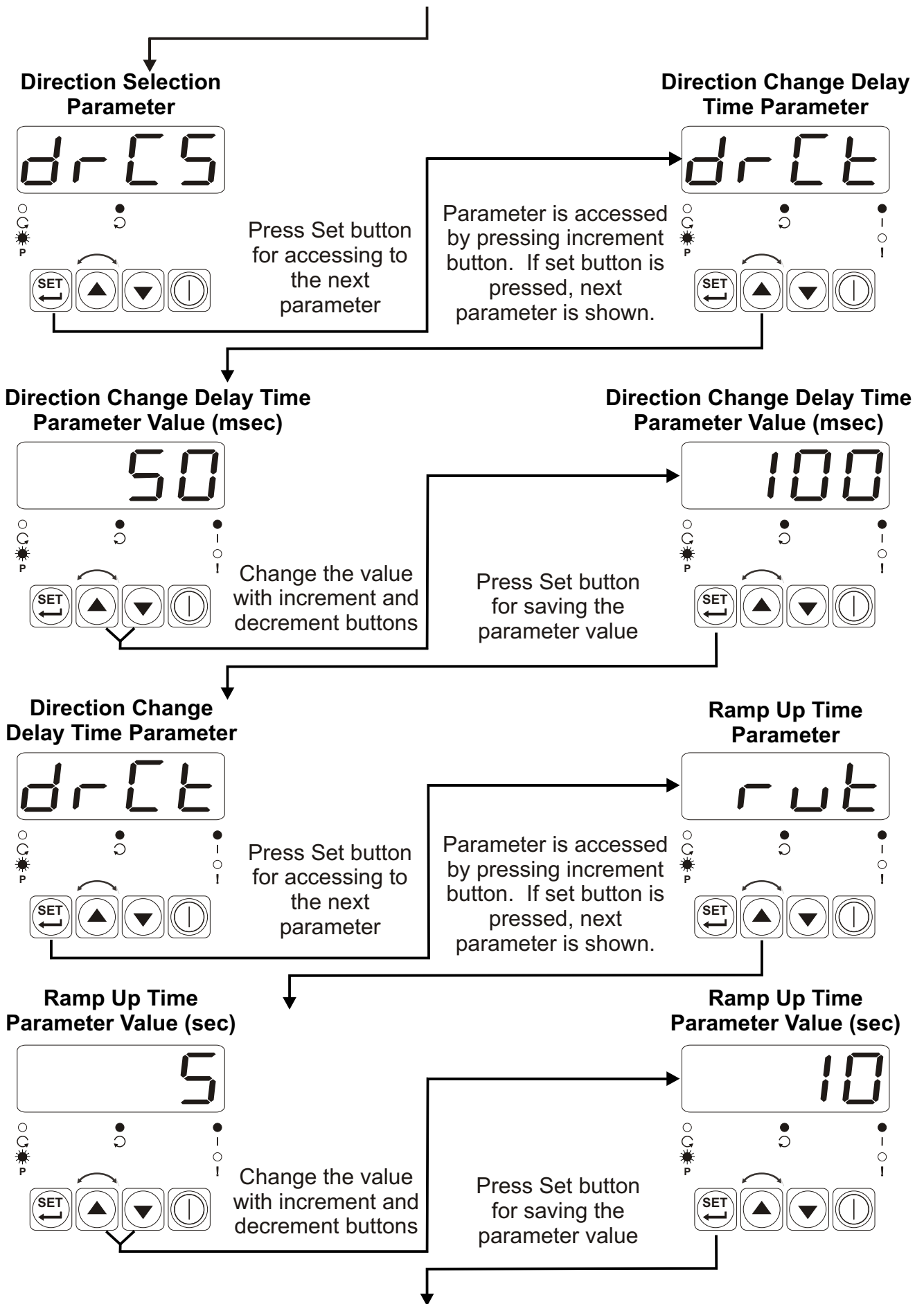

If no operation is performed in Programming mode for 20 seconds, device turns to operation screen automatically.

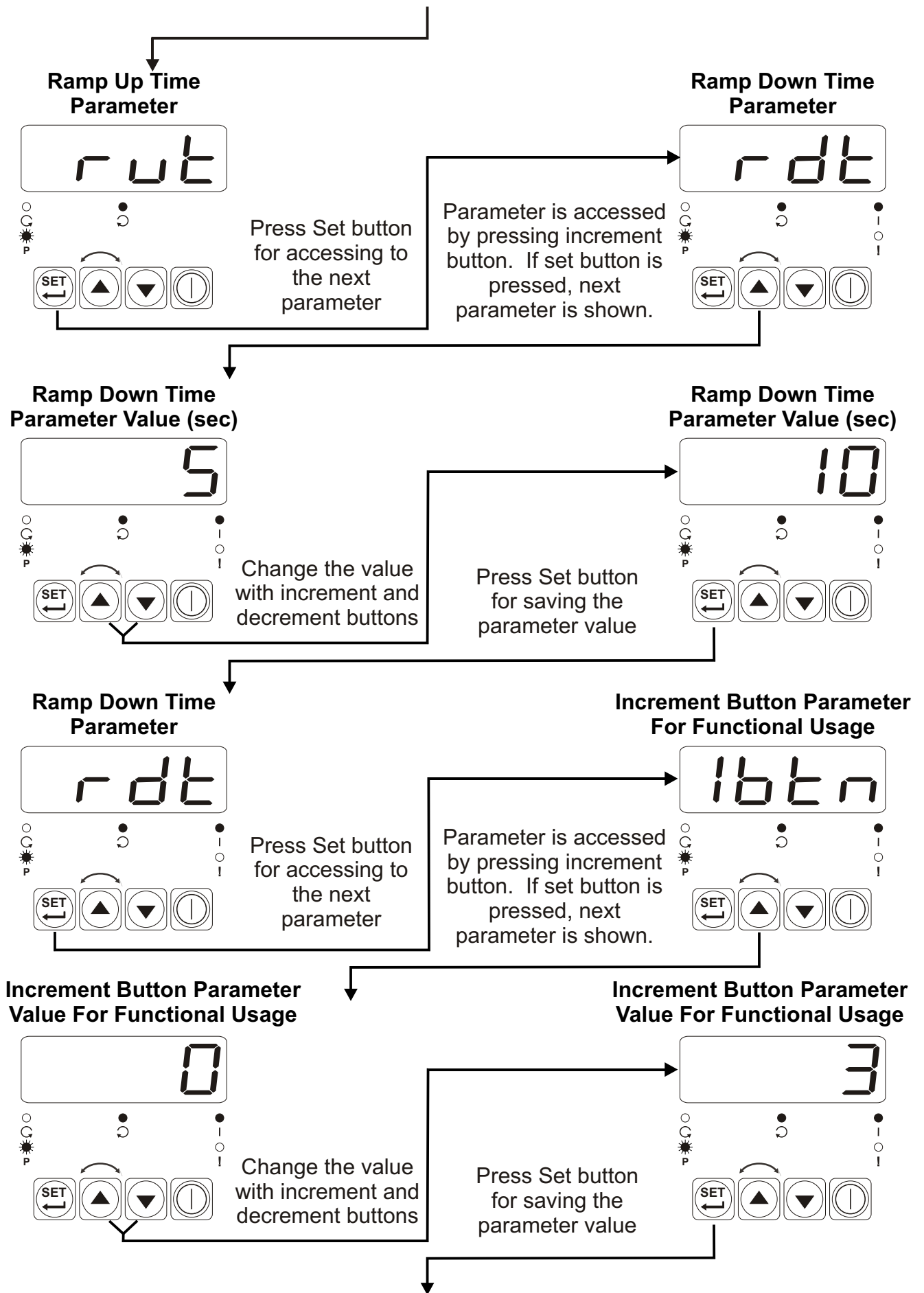

If no operation is performed in Programming mode for 20 seconds, device turns to operation screen automatically.

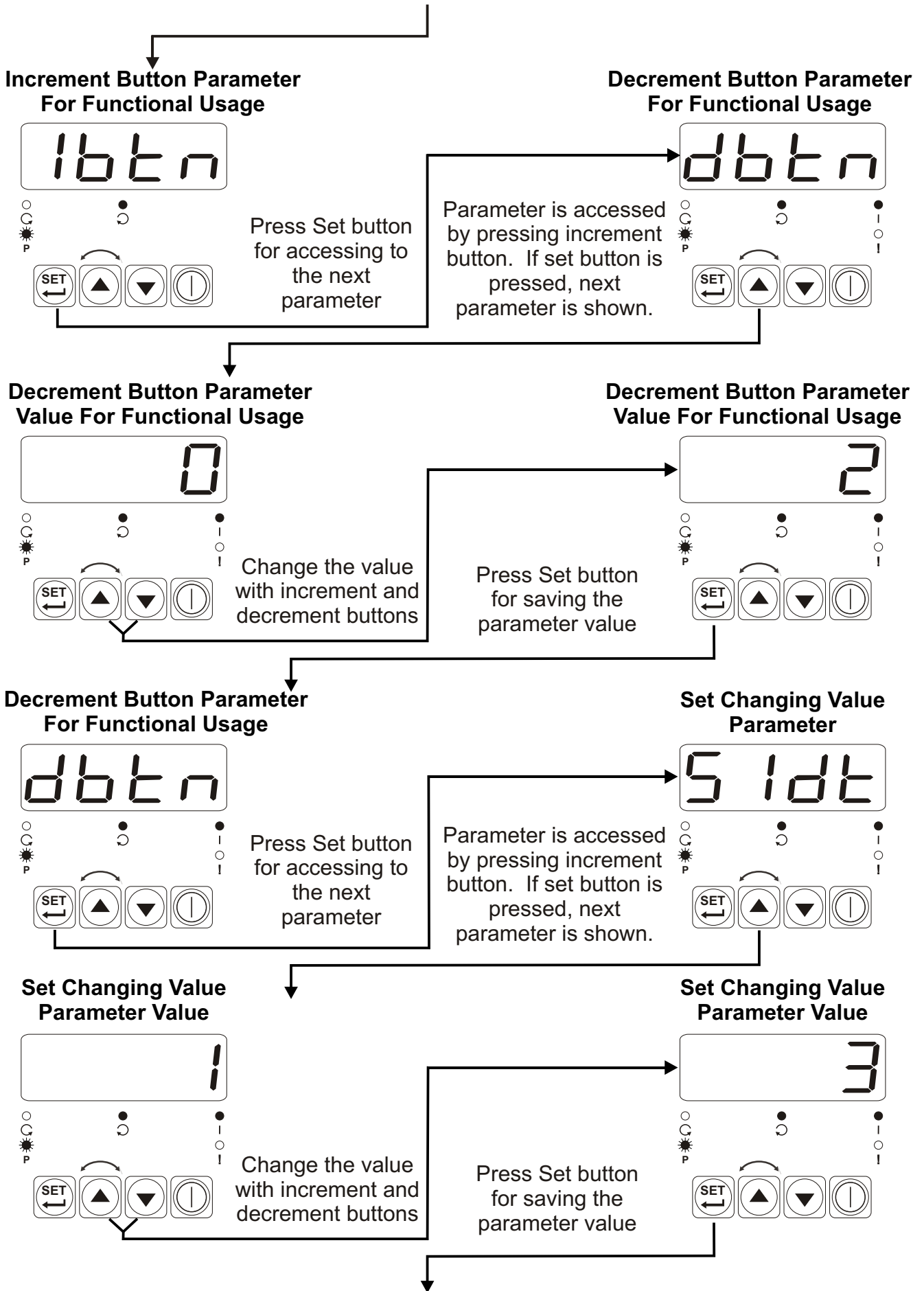

If no operation is performed in Programming mode for 20 seconds, device turns to operation screen automatically.



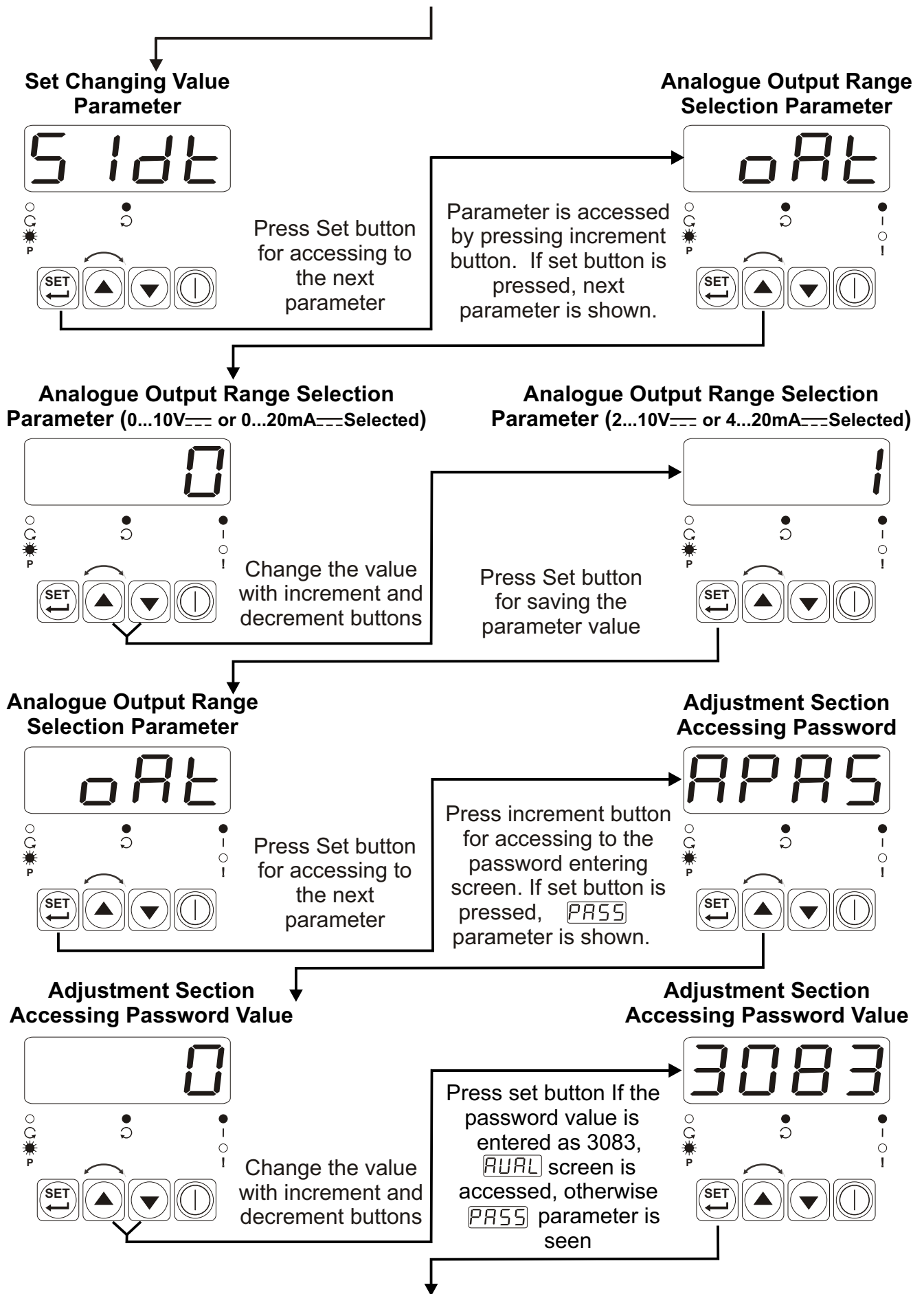

If no operation is performed in Programming mode for 20 seconds, device turns to operation screen automatically.

### Adjustment Value Parameter



Parameter is accessed by pressing increment button. If set button is pressed, next parameter is shown.

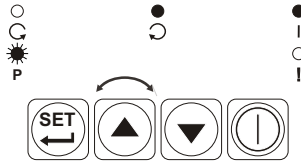

### Adjustment Value

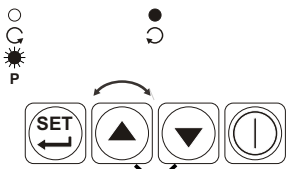

Change the value with increment and decrement buttons

### Adjustment Value

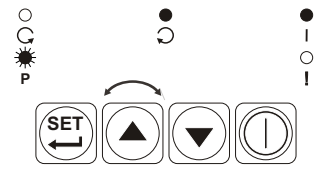

Press Set button for saving the parameter value

### Adjustment Value Parameter

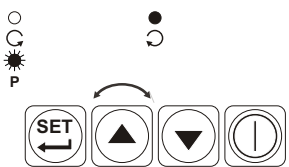

Press Set button for accessing to the next parameter

### Programming Section Accessing Password

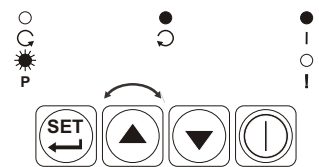

Parameter is accessed by pressing increment button. If set button is pressed, next parameter is shown.

### Programming Section Accessing Password Value

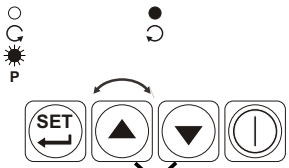

Change the value with increment and decrement buttons

### Programming Section Accessing Password Value

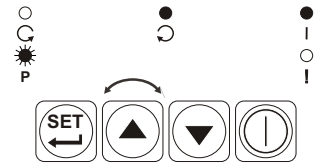

Press Set button for saving the parameter value



If no operation is performed in Programming mode for 20 seconds, device turns to operation screen automatically.

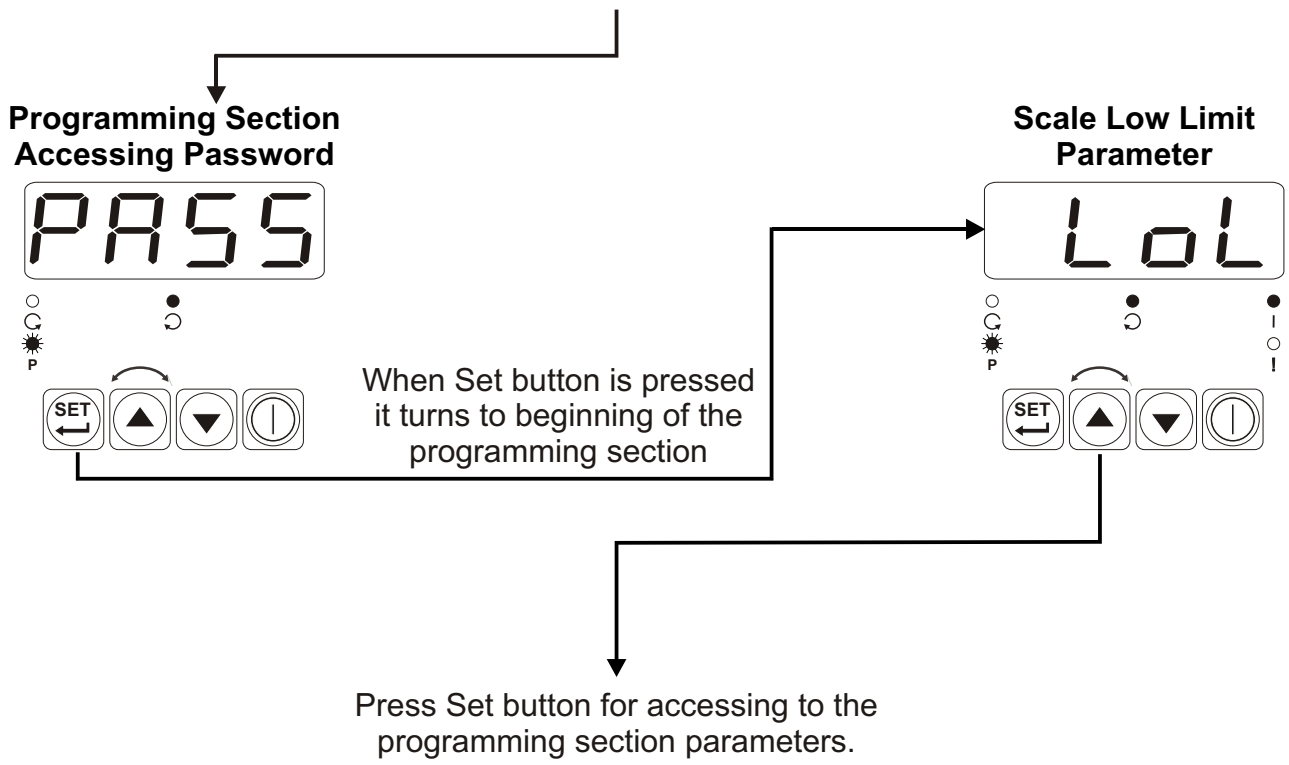

#### 4.6. Motor Start/Stop Operation

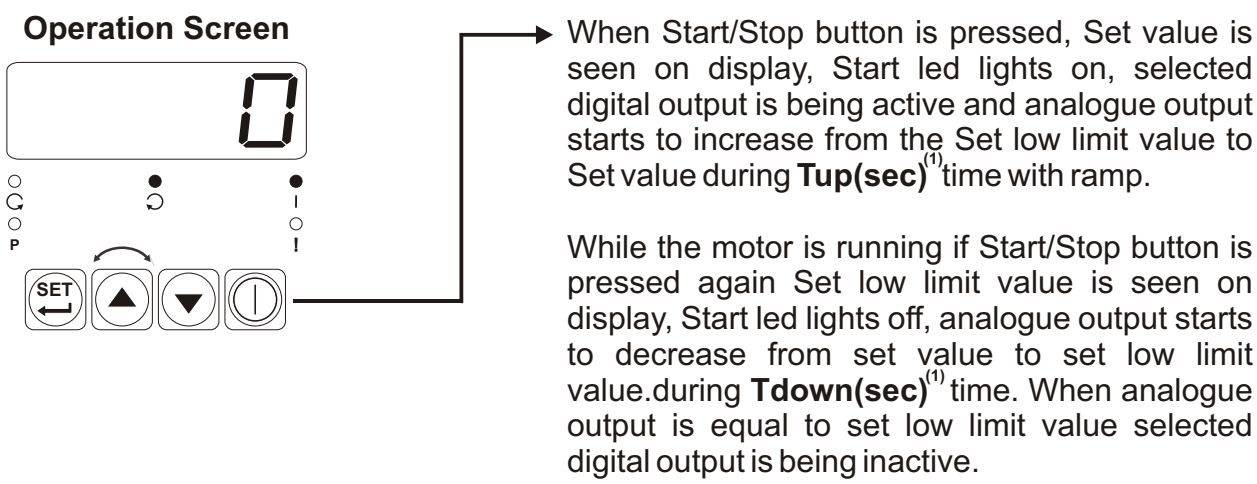

(1) Please refer to **Figure 4.6** for Tup and Tdown time



If no operation is performed in Programming mode for 20 seconds, device turns to operation screen automatically

## 5. Failure Message in EPM-7790 Unit

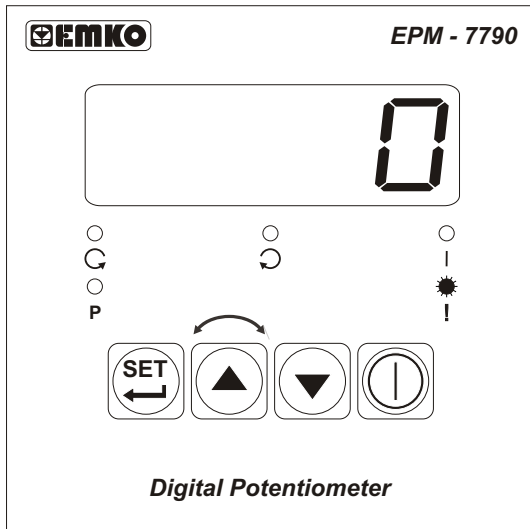

When Error input is being active, Error led starts to blink.

The Unit passes to the stop position.

## 6. Specifications

<b>Device Type</b>	: Control Panel For V/F Speed Controller
<b>Housing&amp;Mounting</b>	: 72mm x 72mm x 95.5mm DIN Size 43700 plastic housing for panel mounting. Panel cut-out is 69x69mm.
<b>Protection Class</b>	: NEMA 4X (IP65 at front, IP20 at rear).
<b>Weight</b>	: Approximately 0.16Kg.
<b>Environmental Rating</b>	: Standard, indoor at an altitude of less than 2000 meters with none-condensing humidity.
<b>Storage / Operating Temperature</b>	: -40 °C to +85 °C / 0 °C to +50 °C
<b>Storage / Operating Humidity</b>	: 90 % max. (None condensing)
<b>Installation</b>	: Fixed Installation
<b>Overvoltage Category</b>	: II.
<b>Pollution Degree</b>	: II. Office or workplace, none conductive pollution
<b>Operating Conditions</b>	: Continuous
<b>Supply Voltage and Power</b>	100-240 V ~ (-%15;+%10) 50/60 Hz. 2VA 24V ~ (-%15;+%10) 50/60 Hz. 2VA 24V===(-%15;+%10) 2W
<b>Electrical Specification of Digital Input</b>	:Max. Permissible Voltage 30V=== Min. High Level 7V=== Max. Low Level 5V===
<b>Electrical Specification of Digital Outputs</b>	:Max. Permissible Voltage 30V=== Max. Output Current 5mA@30V=== Min. High Level 7V=== Max. Low Level 5V===
<b>Analogue Output</b>	: 0/2...10V=== (Max.10mA) or 0/4...20mA===
<b>Analogue Output Accuracy</b>	: ± % 0.1
<b>Display LED</b>	: 14 mm Red 4 digits LED Display : Start(Red), Forward Direction(Red), Reverse Direction (Red), Error(Red), P(Red) 3 mm Led

## 7. Other Informations

### Manufacturer Information:

Emko Elektronik Sanayi ve Ticaret A.Ş.  
Demirtaş Organize Sanayi Bölgesi Karanfil Sk. No:6 16369  
BURSA/TURKEY  
Phone : +90 224 261 1900  
Fax : +90 224 261 1912

### Repair and Maintenance Service Information:

Emko Elektronik Sanayi ve Ticaret A.Ş.  
Demirtaş Organize Sanayi Bölgesi Karanfil Sk. No:6 16369  
BURSA/TURKEY  
Phone : +90 224 261 1900  
Fax : +90 224 261 1912



*Thank you very much for your preference to use Emko Elektronik Products.*

[www.emkoelektronik.com.tr](http://www.emkoelektronik.com.tr)