

CLASSIC II

FOOT SWITCH

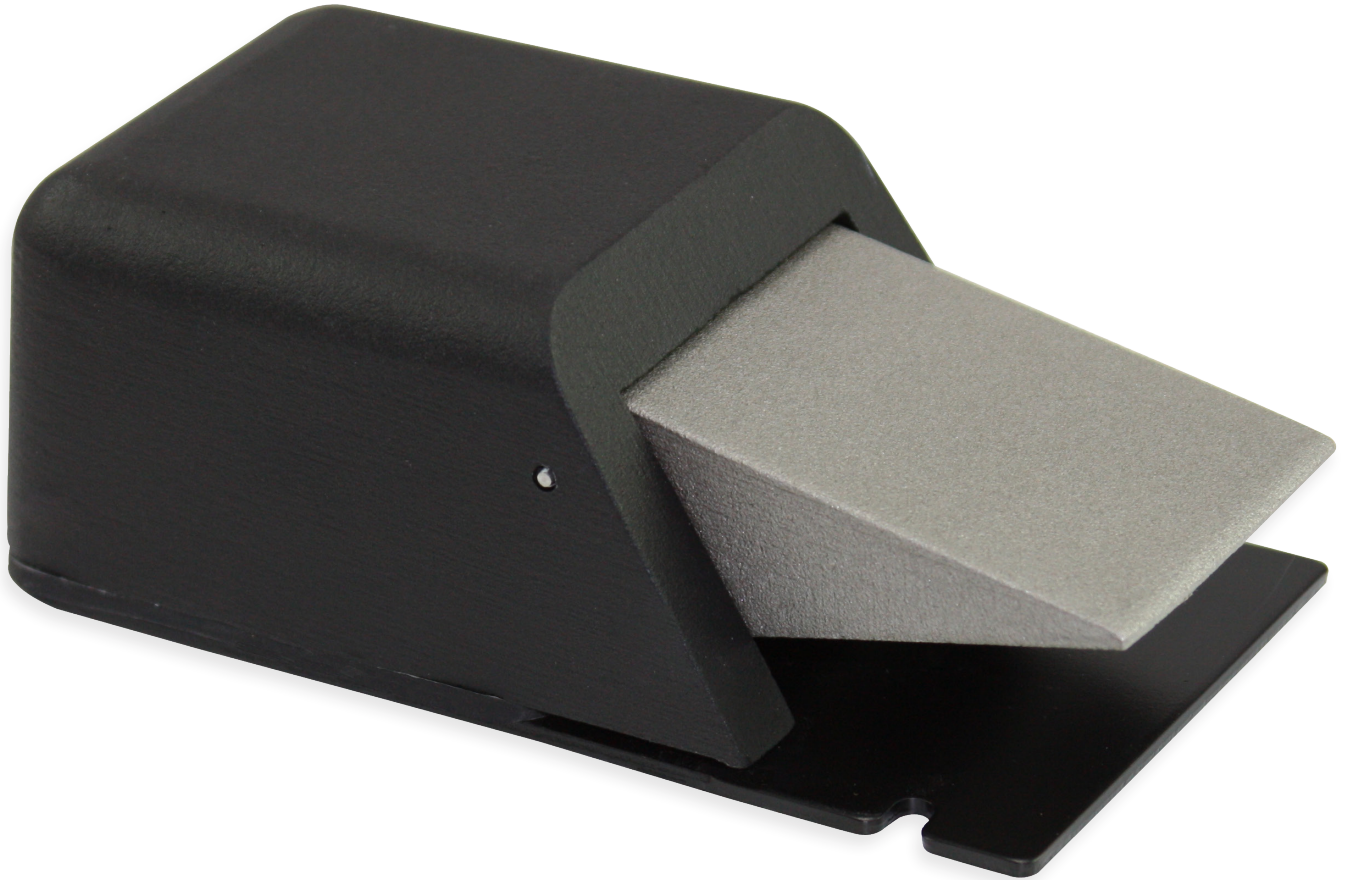

- ▲ The LINEMASTER® Classic II foot switch series is the second generation for the Classic family of pedals. The Classic II is a versatile foot switch that can be utilized in a wide range of applications and standard models include a guarded and unguarded options. The rugged cast aluminum housing offers an IP56 degree of protection. The guarded versions are designed with a heavy gauge steel full guard that covers the entire foot switch for added foot protection and also prevents faulty actuation. Contact Linemaster for a quotation on a custom variation built to your specifications.



LINEMASTER Switch Corporation
Tel (860) 974-1000

29 Plaine Hill Road, P.O. Box 238
Woodstock, Connecticut 06281-0238 USA
Fax (800) 974-FOOT(3668)

FEATURES:

- Cast Aluminum Body and Treadle with Steel Base Plate and Nonskid Base Pad
- Single 3/4"-14 N.P.T. Threaded Conduit Entry is Standard
- All Models Single Stage Momentary Contact
- EN 60529 Degree of Protection IP56
- Heavy Gauge Steel Full Guard Available
- Two Holes Provided for Rigid Mounting to Floor or Equipment
- Versatility of this Model Makes it Ideal
- NEMA Types 1, 2, 4, & 13



GUARDED SINGLE MODEL
 SIZE: 5.19 in x 5.90 in x 7.27 in
 WEIGHT: 2.75 lbs.

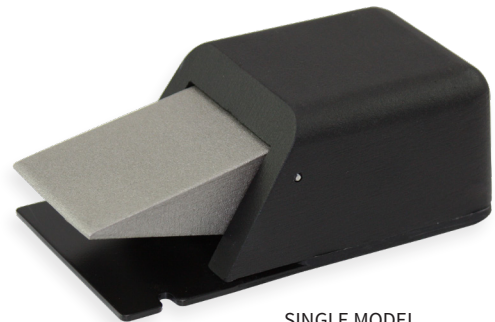

SINGLE MODEL
 SIZE: 2.25 in x 3.50 in x 6.20 in
 WEIGHT: 1.50 lbs.

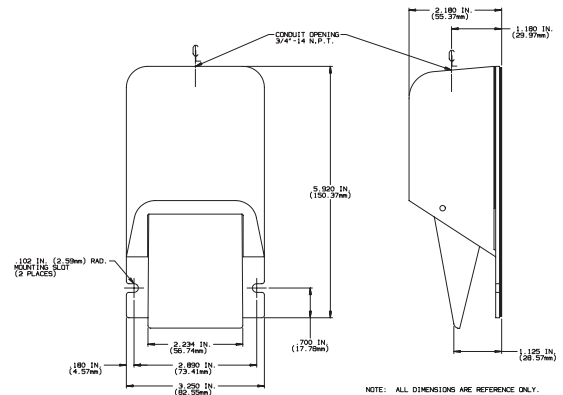
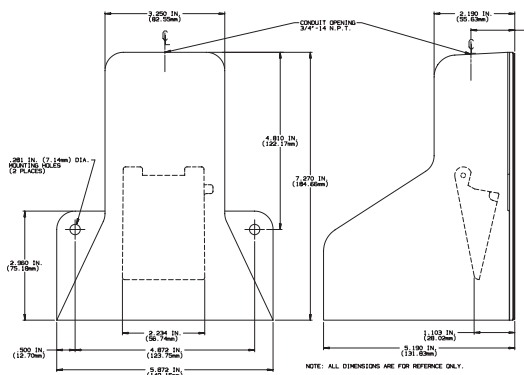

Agency Approvals	Catalog No.	Description	Type	Circuit	Form	Electrical Rating
	78SN1	Momentary	UnGuarded	SPDT	C	20A 125-250 VAC 1 H.P. 125-250 VAC Heavy Pilot Duty 250 VAC Maximum
	78SN2	Momentary	UnGuarded	DPDT	C	
	78SH1	Momentary	UnGuarded	SPDT	C	
	78SH2	Momentary	UnGuarded	DPDT	C	