

# 29 Series

## Mechanical Stroke Counter

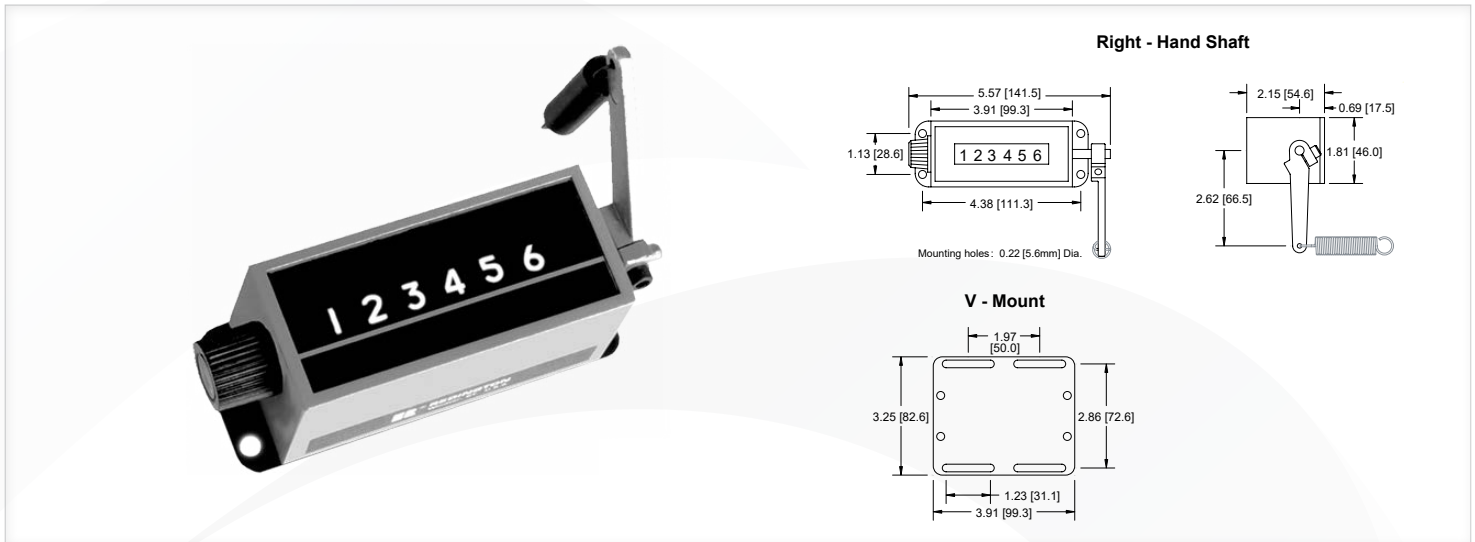

A 6 figure, general purpose heavy duty industrial stroke counter designed for high count rates and continuous operation even under the most adverse operating conditions. Corrosion resistant material and finishes. Large, easy-to-read numbers.

### Key Features

- Heavy duty
- High count rates
- Corrosion resistant
- Optional special mounting bases
- Optional Lever and Spring

### Applications

- Punch press
- Shears
- Cement trucks

### Specification

<b>Figures</b>	6 figures, white on black, 0.30' [7.6mm] high
<b>Reset</b>	Knob
<b>Speed</b>	1,000 counts/minute
<b>Rotation</b>	Top-coming
<b>Count Stroke</b>	40° Min - 70° Max.
<b>Shaft Extension</b>	Right-hand
<b>Shaft Diameter</b>	0.25" [6.4mm]
<b>Operating Life</b>	Beyond 100 million counts
<b>Temp. Range</b>	-15°F to +140°F [-26°C to +60°C]
<b>Weight</b>	18 oz. [510g]

## Mechanical Rotation

Totalizing counters are used to sum the total number of cycles or inputs to a device. These counters have no “outputs”. Totalizers can be Mechanical, Electromechanical or Electronic.

Totalizers are typically used to total cycle count, piece count, and linear length or to indicate position. Displays for Mechanical & Electromechanical Totalizers are molded figure wheels usually displaying 0-9 digits on a contrasting background and have a count capacity of 3-8 figures.

### Mechanical Totalizers

The input for Mechanical Totalizers can be Rotary, Stroke or Rotary Ratchet. Mechanical Totalizers require no operating power or sensor and are easy to install. For hand operated applications you need to consider our Model 46 with thumb lever option.

### Basic operation of a mechanical stroke counter

The illustration (right) shows the lever in the rest position with a total shaft rotation of  $X+Y+Z$ . Although these angles may differ from model to model, the total shaft rotation contains a pre-travel ( $X$ ), a count stroke ( $Y$ ), and an over-travel ( $Z$ ). The lever must start in the pre-travel area and continue through to the over-travel area to register a count. It is recommended that the spring furnished with the counter be used to simplify adjustment of count stroke to drive mechanism.

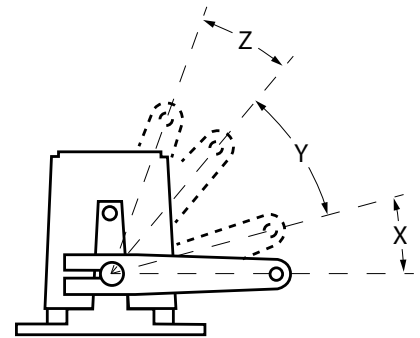

Note: This illustrates rotations 2 and 3 only.

### SHAFT ROTATIONS:

Arrows indicate shaft rotation to increase count:

**Left-hand top-coming:**  
(rotation #1)

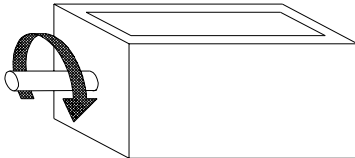

**Left-hand top-going:**  
(rotation #2)

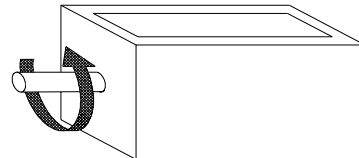

**Right-hand top-coming:**  
(rotation #3)

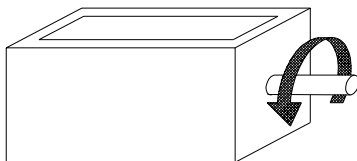

**Right-hand top-going:**  
(rotation #4)

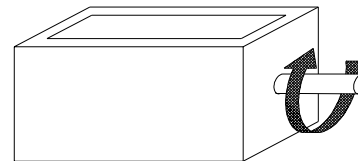

## Part Numbers

<b>1-2936</b>	Right-hand, top-coming, standard reset knob
<b>V1-2936</b>	Right-hand, top-coming, standard reset knob, V-base
<b>200700-010S</b>	Spring and Lever Kit