



Data Sheet

Heating cable

RS stock numbers

256-244, 665-7419, 665-7413, 703-3108, 703-3101, 703-3105, 379-744, 665-7422, 665-7425, 703-3114, 703-3117, 703-3111, 379-750, 665-7429, 665-7438, 703-3120, 703-3123, 703-3127.

RS Cut to length heat tracing system

The RS Heater Cable is designed to be cut from reel lengths and site terminated to suit pipework. The heating tape consists of a number of short heating zones, each connected across a pair of continuous bus-wire conductors.

Each complete heating zone will give its full rated design output with circuit voltage applied to the bus-wire conductors.

RS heater cable has a core comprising two bus-wire conductors contained within an extruded silicone rubber sheath. The sheath is notched on alternate sides at 1 metre intervals to expose a short section of bus-wire conductor.

Nichrome resistance wire is wrapped at regular spacing around the core as a continuous conductor, making contact with the bus-wires at the exposed points.

After completion of the heater conductor wrapping, a high temperature soldered joint is made at each contact point ensuring that a number of conductor strands are securely bonded to the bus-wires.

An extruded outer sheath of silicone rubber is then placed over the core and heater element to complete the heater tape assembly.

Features

- Cut to length
- Easy to terminate
- Suitable for internal and external Freeze protection and temperature maintenance, hot water lines, oil and chemical lines, sprinkler system mains and supply piping (as listed in Clause 1 BS EN 62395-1:2006).
- Manufactured to BS EN 62395-1:2006

Specification

Location _____ Non hazardous areas

Construction

Conductors (RS StockNumbers) _____ Copper stranded
256-244, 665-7419, 665-7413, 703-3108, 703-3101, 703-3105 _____ 32/0.2mm

379-744, 665-7422, 665-7425, 703-3114, 703-3117, 703-3111, 379-750, 665-7429, 665-7438, 703-3120, 703-3123, 703-3127 _____ 30/0.25mm

Core _____ Silicone rubber

Heater element _____ Nickel/chrome 80/20

Solder _____ High melting point 296°C

Outer Sheath _____ Silicone rubber

Dimensions:

256-244, 665-7419, 665-7413, 703-3108, 703-3101, 703-3105

Width _____ 7.5mm

Thickness _____ 3.94mm

Heater zones _____ 1000mm

Dimensions:

379-744, 665-7422, 665-7425, 703-3114, 703-3117, 703-3111, 379-750, 665-7429, 665-7438, 703-3120, 703-3123, 703-3127

Width _____ 13.3mm

Thickness _____ 8.5mm

Heater zones _____ 1000mm

Withstand temperatures (non-operative)

Maximum _____ 200°C

Minimum _____ -60°C

Maximum recommended pipe temperature (cable energised)

- 15w/m Cable _____ 160°C

- 20w/m Cable _____ 145°C

- 40w/m Cable _____ 90°C

Max Circuit Length Supply voltage: 240V

256-244, 665-7419, 665-7413 _____ 100m

379-744, 665-7422, 665-7425 _____ 120m

379-750, 665-7429, 665-7438 _____ 90m

Max Circuit Length Supply voltage: 110V

703-3108, 703-3101, 703-3105 _____ 53m

703-3114, 703-3117, 703-3111 _____ 69m

703-3120, 703-3123, 703-3127 _____ 53m

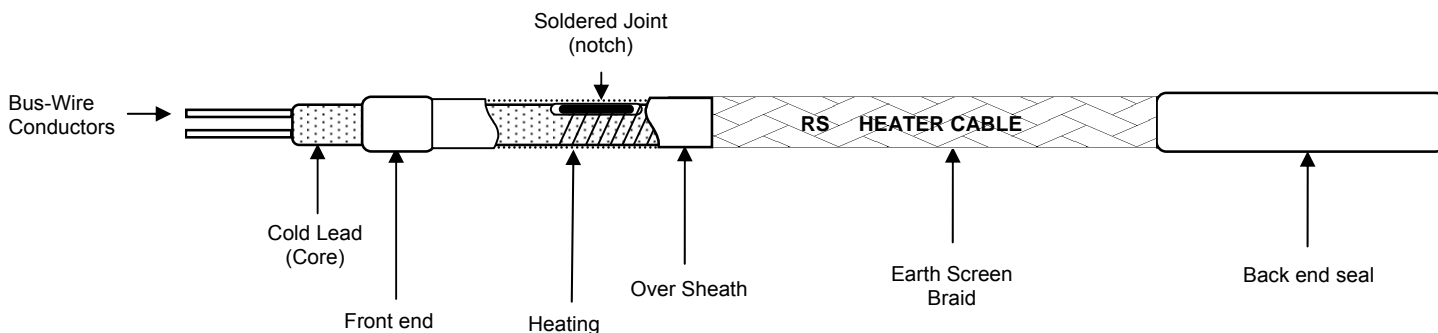

Electrical

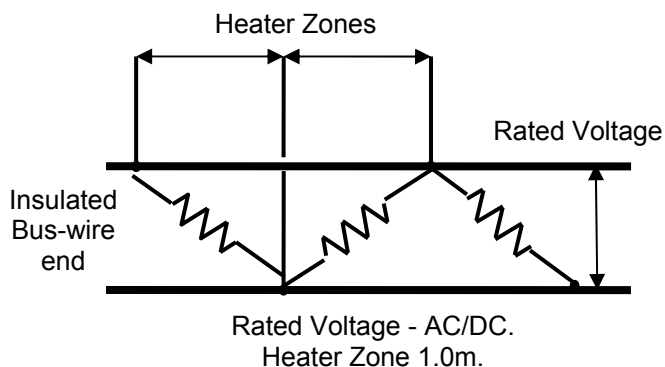

A 30mA trip Residual Current Circuit Device (RCCB) or Earth Leakage Circuit Breaker (ELCB) should be used with heating tapes.

Heat Losses (to BS EN 62395-2:2008)

To calculate heat loss per metre of pipe:-

$$\text{Heat losses W/m} = \frac{2\pi k (T_p - T_a)}{\ln\left(\frac{D_2}{D_1}\right)}$$

where:-

k = Thermal Conductivity of insulation layer at its mean temperature

T_p = Maintain Temperature

T_a = Minimum Ambient temp

D₁ = Inside Diameter of the Insulation Layer

D₂ = Outside Diameter of the Insulation Layer

Thermal Conductivity (k) for Mineral/Glass Fibre

Mean Temperature °C	10	50	100	200
k	0.032	0.035	0.43	0.062

A Design Factor Allowance should be taken of:
Maximum heater resistance tolerance (± 10%) and
Voltage variation (± 6%)

$$= \frac{1.1}{(0.94)^2} = 1.25 \times \text{Heat Loss.}$$

A further design factor of 10% may be added.

Installation

- Heating tape should be installed on clean, dry pipe free from burrs, weld splatter or any rough, sharp projections.
- Heating tape may be straight traced or spiralled along the pipe. If straight traced, the heating tape should be held in place with adhesive tape at 300mm intervals. For spiral tracing, fixing at 1m intervals is suitable.
- Use the correct adhesive tape suitable for the temperature application.
- A 30mA trip Residual Current Circuit Device (RCCB) or Earth Leakage Circuit Breaker (ELCB) is recommended for use with heating tapes.
- If in doubt about electrical installation consult a qualified electrician.
- Use mineral or glass fibre insulation and ensure that it is kept dry for maximum efficiency.
- Fit warning labels supplied on the outside of thermal insulation at approximately 3-meter intervals.
- For PVC, ABS, Polythene and other 'Plastic' pipes use heating tape not exceeding 12 watts per meter and having an earth screen covering. It is recommended that heating tape be covered in 50mm wide adhesive aluminium foil. An RCC or ELCB unit must be used in conjunction with this type of installation.
- It is recommended that all Heating tape should be installed in conjunction with a thermostatic controller.
- Heating cable should be terminated using a suitable **RS** termination kit.

HEATING TAPE STRAIGHT TRACED FIXED AT MAX 300MM

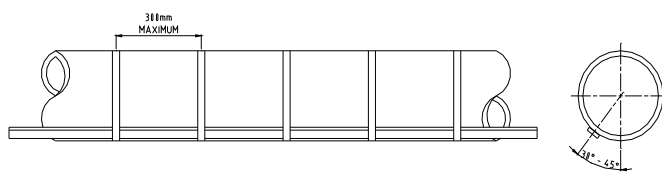

HEATING TAPE SPIRALLY TRACED FIXED AT 1000MM

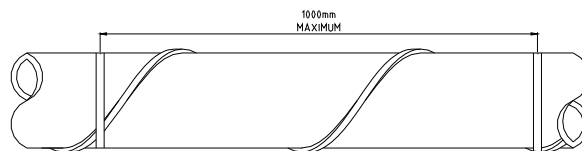

Instruction Leaflet
Bendienungsanleitung
Hojas de instrucciones
Feuille d'instructions
Foglio d'istruzioni
Betjeningsvejledning
Instructies
Instruktionsfolder

- Heating Cable Termination Kit (GB)
- Heizband-Abschluss-Set (D)
- Kit de terminals para cable de calentamiento (E)
- Kit de terminal de cable chauffant (F)
- Kit di terminazione cavo di riscaldamento (I)
- Aftslutningsæt til varmekabler (DK)
- Aansluitset voor verwarmingskabel (NL)
- Anslutningsatts till värmekabel (SE)

1

Pull Earth Braid Back

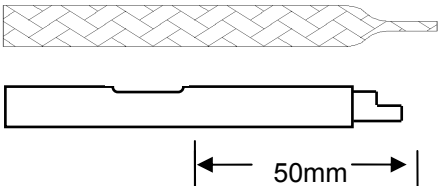

50mm

(GB) Heating Joint	(I) Giunto di riscaldamento
(D) Heizverbindung	(DK) Varmeled
(E) Junta de calentamiento	(NL) Verwarmingsverbinding
(F) Joint chauffant	(SE) Värmefog

3

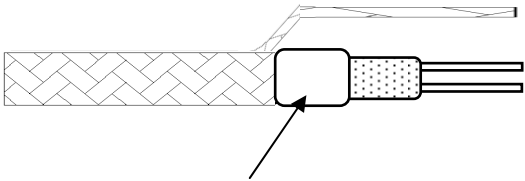

(GB) Small silicon	(I) Silicone piccolo
(D) Kleiner Silikonschlauch	(DK) Lille silikonerør
(E) Tubo de silicona pequeño	(NL) Kleine siliconenslang
(F) Petit tube en silicone	(SE) Litet silikonrör

2

Pull Earth Braid Back, Twist & fit 'O' Ring

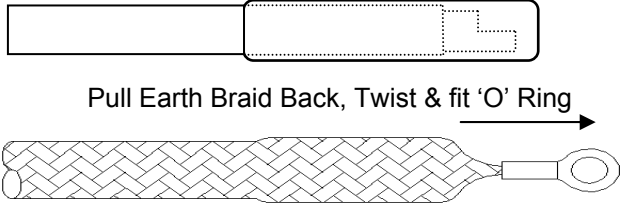

(GB) Blank end	(I) Terminazione estremità vuota
(D) Abschluss am blanken Ende	(DK) Kabelafslutning
(E) Terminación de aislamiento	(NL) Aftuiting voor blind Uiteinde
(F) Terminaison d'extrémité obtée	(SE) Ändkåpa



GB

ENGLISH

256-109 for use with Heating Cables: 256-244, 665-7419, 665-7413, 703-3108, 703-3101, 703-3105

When used with RS Heat cable (RS stock no. 256-244, 665-7419, & 665-7413, 703-3108, 703-3101, 703-3105) this kit will be sufficient for three sets of terminations. The kit consists of the following:

- 3 end seal moulds
- 3 small silicone tubes
- 1 tube of silicon adhesive
- 3 Warning labels
- 3 'O' Ring Crimps

665-7431 for use with Heating Cables: 379-744, 665-7422, 665-7425, 703-3114, 703-3117, 703-3111, 379-750, 665-7429, 665-7438, 703-3120, 703-3123, 703-3127

When used with RS Heat cable (RS stock no. 379-744, 665-7422, 665-7425, 703-3114, 703-3117, 703-3111, 379-750, 665-7429, 665-7438, 703-3120, 703-3123, 703-3127) this kit will be sufficient for three sets of terminations. The kit consists of the following:

- 3 end seal moulds
- 3 small silicone tubes
- 1 tube of silicon adhesive
- 3 M20 Entry Glands c/w/ Locknut
- 3 Warning labels
- 3 'O' Ring Crimps

Preparations

1. Look/feel for the first heating joint in the cable. Cut 50mm from the joint.
2. Measure the exact length of tape required and look/feel for the nearest heating joint.
3. Then add up to 950mm and cut the cable. (do not cut closer than 50mm from the next heating joint).

Blank end termination (short cold tail)

1. Pull back the earth screen braid to expose the internal cable.
2. Strip off 6mm of the silicon sheath with a sharp knife.
3. Unwind the heating element.
4. Cut along centre between the conductors and cut back one insulated conductor 3mm (figure 1).
5. Squeeze some silicon adhesive into an end seal mould and cover the end of the heating tape.
6. Pinch the end mould to exclude as much air as possible releasing pressure at the same time (figure 2).
7. Pull braid back over the end seal and twist end.
8. Leave to set for approximately 30mins.

Cold tail section termination

1. If a cable gland is to be used in the installation fit it to the cable at this stage. (For suitable cable glands see current RS catalogue).
2. Bend the cable at approximately 100-150mm and pull through the earth screen braid to expose the internal cable and leave you with an earth lead.
3. Strip off the silicone sheath to within 25mm from the earth braid.
4. Unwind and cut off heating element.
5. Apply silicone adhesive at the point where the over sheath has been removed.

- Intended use(s) Freeze protection and temperature maintenance, hot water lines, oil and chemical lines, sprinkler system mains and supply piping (as listed in Clause 1 BS EN 62395).
- Ground-fault equipment protection is required for each circuit
- De-energize all power circuits before installation or servicing
- Keep ends of trace heaters and kit components dry before and during installation
- Caution: Do not use in areas subject to high mechanical loads or impact, This heating tape is intended for use in applications with low risk of mechanical damage.
- The metal sheath, braid, screen or equivalent electrically conductive covering of the trace heater must be connected to an earth terminal
- The presence of the trace heaters shall be made evident by the posting of caution signs or markings at appropriate locations and/or at frequent intervals along the circuit.
- Heating tape should be installed on clean, dry pipe free from burrs, weld splatter or any rough, sharp projections.
- Heating tape may be straight traced or spiralled along the pipe. If straight traced, the heating tape should be held in place with adhesive tape at 300mm intervals. For spiral tracing, fixing at 1m intervals is suitable.
- Use the correct adhesive tape suitable for the temperature application.
- If in doubt about electrical installation consult a qualified electrician.
- Use mineral or glass fibre insulation and ensure that it is kept dry.
- Fit warning labels supplied on the outside of thermal insulation at approximately 3-meter intervals.
- For PVC, ABS, Polythene and other 'Plastic' pipes use heating tape not exceeding 12 watts per meter and having an earth screen covering. It is recommended that heating tape be covered in 50mm wide adhesive aluminium foil. An RCC or ELCB unit must be used in conjunction with this type of installation.